

# Quality Assurance Project Plan

CONTRACT No.: W912DQ-18-D-3008

DELIVERY ORDER: W912DQ19F3048

**700 South 1600 East PCE Plume Site,  
Operable Unit 2  
Salt Lake City, Utah**

**U.S. Army Corps of Engineers  
Kansas City District**



**Department of Veterans Affairs  
Veterans Health Administration Salt Lake City  
Health Care System**



November 2019

**CDM  
Smith®**



# Title and Approval Sheet (A1)

## Quality Assurance Project Plan (QAPP) Version 0

**CDM Smith**  
**Project Manager:**   
Date: 12/2/2019  
CDM Smith

**CDM Smith**  
**Technical Reviewer:**   
Date: 12/2/2019  
CDM Smith

Digitally signed by Neil Smith  
DN: C=US, E=smithn1@cdmsmith.com,  
O=CDM Smith Inc., CN=Neil Smith  
Date: 2019.12.02 15:11:06-07'00'

**CDM Smith**  
**QA Reviewer:** **Jeniffer Oxford**   
Date: 11/24/19  
CDM Smith

Digitally signed by Jeniffer Oxford  
DN: c=us, E=jeniffer.oxford@cdmsmith.com, O=CDM Smith, OU=TSU  
CN=Jeniffer Oxford  
Reason: I have reviewed this document  
Date: 2019.12.02 17:05:14-05:00'

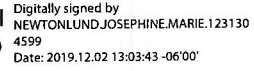
**USACE Project**  
**Manager:** **NEWTONLUND.JOSEPH**   
Date: 12/2/2019  
USACE

Digitally signed by  
NEWTONLUND.JOSEPHINE.MARIE.123130  
4599  
Date: 2019.12.02 13:03:43 -06'00'

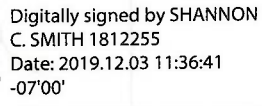
**VA COR/Remedial**  
**Program Manager,**  
**CERCLA:** **SHANNON C.**   
Date: 12/03/2019  
Department of Veteran's Affairs

Digitally signed by SHANNON  
C. SMITH 1812255  
Date: 2019.12.03 11:36:41  
-07'00'

**EPA Project**  
**Manager:** **C. Mark Aguirre**   
Date: 12/3/2019  
EPA Region 8

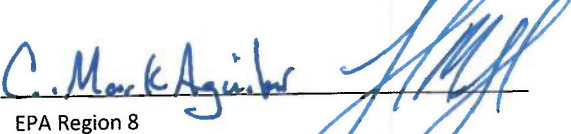
**EPA Quality**  
**Assurance**  
**Manager:** **C. Mark Aguirre**   
Date: 12/3/2019  
EPA Region 8





# Table of Contents

|  |            |
|--|------------|
| <b>Title and Approval Sheet (A1)</b> .....   | <b>i</b>   |
| <b>Acronyms and Abbreviations</b> .....  | <b>vii</b> |
| <b>Introduction</b> .....  | <b>1-1</b> |
| <b>Project Management (EPA Group A)</b> .....  | <b>2-1</b> |
| 2.1 Project/Task Organization (A4) .....   | 2-1        |
| 2.1.1 Veterans Health Administration Program Manager and Deputy Program Manager ...  | 2-4        |
| 2.1.2 U.S. Army Corps of Engineers Project Manager .....                             | 2-4        |
| 2.1.3 Project Manager .....  | 2-4        |
| 2.1.4 Quality Assurance Manager .....  | 2-4        |
| 2.1.5 Subject Matter Expert.....   | 2-4        |
| 2.1.6 Safety & Health Manager .....  | 2-4        |
| 2.1.7 Data Manager .....   | 2-4        |
| 2.1.8 Project Chemist .....  | 2-5        |
| 2.1.9 Project Engineer .....   | 2-5        |
| 2.1.10 Laboratory Project Managers.....  | 2-5        |
| 2.2 Problem Definition/Background (A5) .....   | 2-5        |
| 2.2.1 Background.....  | 2-5        |
| 2.2.2 Problem Definition .....   | 2-5        |
| 2.3 Project Description (A6) .....   | 2-6        |
| 2.3.1 Description of Work Tasks.....   | 2-6        |
| 2.3.2 Project Schedule .....   | 2-7        |
| 2.4 Quality Objectives and Criteria (A7).....  | 2-7        |
| 2.4.1 Project Quality Objectives .....   | 2-7        |
| 2.4.2 Data Quality Indicators and Quality Control Sample/Measurement Performance ... | 2-25       |
| 2.5 Special Training/Certification (A8) .....  | 2-27       |
| 2.6 Documents and Records (A9).....  | 2-27       |
| 2.6.1 Analytical Data Package .....  | 2-30       |
| 2.6.2 Electronic Data Deliverable Format.....  | 2-32       |
| 2.6.3 Project Information/Records Storage and Retention .....                        | 2-32       |
| <b>Data Generation and Acquisition (EPA Group B)</b> .....                           | <b>3-1</b> |
| 3.1 Sampling Design (Experimental Design) (B1).....                                  | 3-1        |
| 3.2 Sampling Methods (B2).....   | 3-1        |
| 3.3 Sample Handling and Custody (B3) .....   | 3-2        |
| 3.3.1 Sample Labeling.....   | 3-2        |
| 3.3.2 Packaging and Shipping.....  | 3-2        |
| 3.3.3 Chain of Custody.....  | 3-5        |
| 3.3.4 Custody Seals .....  | 3-6        |
| 3.3.5 Field Notebooks and Field Documentation.....                                   | 3-7        |
| 3.3.6 Corrections to Documentation .....   | 3-7        |
| 3.4 Analytical Methods (B4) .....  | 3-8        |
| 3.4.1 Field Analytical Methods.....  | 3-8        |
| 3.4.2 Laboratory Analytical Methods.....   | 3-9        |
| 3.5 Quality Control (B5).....  | 3-11       |

|   |  |            |
|---|--|------------|
| 3.5.1   | Field Quality Control Procedures .....   | 3-11       |
| 3.5.2   | Laboratory Quality Control Procedures .....  | 3-12       |
| 3.6   | Instrument/Equipment Testing, Inspection, Maintenance (B6) and Calibration (B7)..... | 3-33       |
| 3.6.1   | Field Equipment.....   | 3-33       |
| 3.6.2   | Laboratory Equipment.....  | 3-33       |
| 3.7   | Inspection/Acceptance of Supplies and Consumables (B8) .....                         | 3-34       |
| 3.8   | Data Acquisition Requirements (Non-direct Measurements – B9).....                    | 3-35       |
| 3.9   | Data Management (B10).....   | 3-35       |
| <b>Assessment and Oversight (EPA Group C).....</b>      |  | <b>4-1</b> |
| 4.1   | Assessments and Response Actions (C1) .....  | 4-1        |
| 4.1.1   | Laboratory Audits.....   | 4-1        |
| 4.1.2   | Corrective Action Procedures.....  | 4-1        |
| 4.2   | Reports to Management (C2).....  | 4-3        |
| 4.2.1   | Report Type and Frequency .....  | 4-3        |
| <b>Data Validation and Usability (EPA Group D).....</b> |  | <b>5-1</b> |
| 5.1   | Data Review, Verification, and Validation (D1) .....                                 | 5-1        |
| 5.1.1   | Field Data Verification.....   | 5-1        |
| 5.1.2   | Laboratory Data Reduction, Review, and Approval .....                                | 5-1        |
| 5.2   | Verification and Validation Methods (D2) .....                                       | 5-5        |
| 5.3   | Reconciliation with User Requirements (D3).....                                      | 5-5        |
| 5.3.1   | Usability Report.....  | 5-6        |
| 5.3.2   | Project-specific Measurement Performance Criteria .....                              | 5-6        |
| <b>References. ....</b>                                 |  | <b>6-1</b> |

## Appendixes

|            |  |
|------------|--|
| Appendix A | Standard Operating Procedures            |
| Appendix B | Example Chain-of-Custody Documentation   |
| Appendix C | Laboratory Quality Assurance Manuals     |
| Appendix D | Laboratory Standard Operating Procedures |

## List of Tables

|           |   |
|-----------|---|
| Table 2-1 | Project Team Members  |
| Table 2-2 | Data Quality Objectives   |
| Table 2-3 | Project Laboratory – Target Analytes and Reporting Limits – Volatile Organic Compounds in Soil                              |
| Table 2-4 | Project Laboratory – Target Analytes and Reporting Limits – Semivolatile Organic Compounds in Soil                          |
| Table 2-5 | Project Laboratory – Target Analytes and Reporting Limits – Metals in Soil  |
| Table 2-7 | Project Laboratory – Target Analytes and Reporting Limits – Geotechnical and Geochemical Parameters in Soil                 |
| Table 2-8 | Project Laboratory – Target Analytes and Reporting Limits – Volatile Organic Compounds in Soil Gas                          |
| Table 2-9 | Project Laboratory – Target Analytes and Reporting Limits – Volatile Organic Compounds in Water (Groundwater/Surface Water) |

|            |   |
|------------|---|
| Table 2-10 | Project Laboratory – Target Analytes and Reporting Limits – Semivolatile Organic Compounds in Water (Groundwater/Surface Water)                       |
| Table 2-11 | Project Laboratory – Target Analytes and Reporting Limits – Metals in Water (Groundwater/Surface Water)   |
| Table 2-13 | Project Laboratory – Target Analytes and Reporting Limits – General Water Quality/Natural Attenuation Parameters in Water (Groundwater/Surface Water) |
| Table 2-14 | Specialized Training Requirements   |
| Table 3-1  | Recommended Sample Container, Preservation, and Holding Times   |
| Table 3-2  | Quality Control Samples for Field Screening of Volatile Organic Compounds in Soil Gas/Water (HAPSITE)   |
| Table 3-3  | Quality Control Samples (Field and Lab) for Volatile Organic Compounds in Soil and Water  |
| Table 3-4  | Precision and Accuracy for Volatile Organic Compounds in Soil and Water   |
| Table 3-5  | Quality Control Samples (Field and Lab) for Semivolatile Organic Compounds in Soil and Water  |
| Table 3-6  | Precision and Accuracy for Semivolatile Organic Compounds in Soil and Water   |
| Table 3-7  | Quality Control Samples (Field and Lab) for Metals in Soil and Water  |
| Table 3-8  | Precision and Accuracy for Metals in Soil and Water   |
| Table 3-11 | Quality Control Samples (Field and Lab) for Volatile Organic Compounds in Soil Gas  |
| Table 3-12 | Quality Control Samples (Field and Lab) for General Chemistry Parameters in Water   |
| Table 3-13 | Precision and Accuracy for General Chemistry Parameters in Water  |
| Table 3-14 | Quality Control Samples (Field and Lab) for Stable Oxygen and Hydrogen Isotope Parameters in Water  |
| Table 4-1  | Summary of Reports to Management  |
| Table 5-1  | Data Verification Processes for Field and Lab Results   |
| Table 5-2  | Laboratory Data Qualifiers  |
| Table 5-3  | Data Validation Process Summary for Field and Laboratory Results  |
| Table 5-4  | Data Validation Flagging Criteria for Organic Methods   |
| Table 5-5  | Data Validation Flagging Criteria for Inorganic Methods   |

## List of Figures

|            |                            |
|------------|----------------------------|
| Figure 2-1 | Project Organization Chart |
|------------|----------------------------|



# 1 Acronyms and Abbreviations

|    |                                |  |
|----|--------------------------------|--|
| 2  | µg/L                           | microgram(s) per liter   |
| 3  | µg/m <sup>3</sup>              | microgram(s) per cubic meter   |
| 4  | °C                             | degrees Celsius  |
| 5  | %D                             | percent difference   |
| 6  | %R                             | percent recovery   |
| 7  | AOU                            | Accelerated Operable Unit  |
| 8  | aq                             | aqueous  |
| 9  | CA                             | California   |
| 10 | CAR                            | corrective action report   |
| 11 | CAS                            | Chemical Abstracts Service   |
| 12 | CC-ACA                         | Certified Chemist – American Chemical Society                                  |
| 13 | CCV                            | continuing calibration verification  |
| 14 | CERCLA                         | Comprehensive Environmental Response Compensation and Liability Act            |
| 15 | CGWP                           | Certified Groundwater Professional   |
| 16 | CH                             | Certified Hydrogeologist   |
| 17 | CH2M                           | CH2M HILL, Inc.  |
| 18 | CO                             | Colorado   |
| 19 | COPC                           | constituent of potential concern   |
| 20 | CSM                            | conceptual site model  |
| 21 | DAF                            | dilution attenuation factor  |
| 22 | DCV                            | daily calibration verification   |
| 23 | DO                             | dissolved oxygen   |
| 24 | DoD                            | U.S. Department of Defense   |
| 25 | DQO                            | data quality objective   |
| 26 | EB                             | equipment blank  |
| 27 | EDD                            | electronic data deliverable  |
| 28 | EPA                            | U.S. Environmental Protection Agency   |
| 29 | FAR                            | Federal Acquisition Regulation   |
| 30 | FD                             | field duplicate  |
| 31 | FOC                            | fraction of organic carbon   |
| 32 | FSP                            | field sampling plan  |
| 33 | FTL                            | field team leader  |
| 34 | GA                             | Georgia  |
| 35 | GC/MS                          | gas chromatograph/mass spectrometer  |
| 36 | GIS                            | geographic information system  |
| 37 | GPS                            | geographic positioning system  |
| 38 | H <sub>2</sub> SO <sub>4</sub> | sulfuric acid  |
| 39 | HCl                            | hydrochloric acid  |
| 40 | HNO <sub>3</sub>               | nitric acid  |
| 41 | ICAL                           | initial calibration  |
| 42 | ICS                            | interference check sample  |
| 43 | ID                             | identification   |
| 44 | IGES                           | Intermountain GeoEnvironmental Services, Inc.                                  |
| 45 | IS                             | internal standard  |
| 46 | J                              | The analyte was positively identified. The associated numerical value is the   |
| 47 |                                | approximate concentration of the analyte in the sample, or the reported        |
| 48 |                                | concentration is greater than the instrument detection limit but less than the |
| 49 |                                | quality assurance project plan specified reporting limit                       |
| 50 | L                              | liter  |
| 51 | LCL                            | lower control limit  |

|    |                    |  |
|----|--------------------|--|
| 1  | LCS                | laboratory control sample  |
| 2  | LIMS               | laboratory information management system   |
| 3  | m <sup>3</sup> /kg | cubic meter(s) per kilogram  |
| 4  | MB                 | method blank   |
| 5  | MCL                | maximum contaminant level  |
| 6  | MDL                | method detection limit   |
| 7  | mg/kg              | milligram(s) per kilogram  |
| 8  | mg/L               | milligram(s) per liter   |
| 9  | mL                 | milliliter(s)  |
| 10 | MO                 | Missouri   |
| 11 | MPC                | measurement performance criteria   |
| 12 | MS                 | matrix spike   |
| 13 | MT                 | Montana  |
| 14 | MSA                | method of standard addition  |
| 15 | MSD                | matrix spike duplicate   |
| 16 | NA                 | not applicable   |
| 17 | NaOH               | sodium hydroxide   |
| 18 | NCR                | non-conforming report  |
| 19 | NFG                | National Functional Guidelines   |
| 20 | OU                 | operable unit  |
| 21 | PB                 | performance based  |
| 22 | PCE                | tetrachloroethene  |
| 23 | PDS                | post digestion spike   |
| 24 | PE                 | Professional Engineer  |
| 25 | PG                 | Professional Geologist   |
| 26 | PID                | photo-ionization detector  |
| 27 | PM                 | project manager  |
| 28 | PMP                | Project Management Professional  |
| 29 | ppbV               | part(s) per billion by volume  |
| 30 | QA                 | quality assurance  |
| 31 | QAM                | quality assurance manager  |
| 32 | QAPP               | quality assurance project plan   |
| 33 | QAS                | quality assurance specialist   |
| 34 | QC                 | quality control  |
| 35 | qPCR               | quantitative polymerase chain reaction   |
| 36 | QSM                | quality systems manual   |
| 37 | R                  | The sample results are rejected owing to serious deficiencies in meeting quality control criteria. The presence or absence of the analyte cannot be verified |
| 38 |                    |  |
| 39 | RDL                | representative detection limit   |
| 40 | RI                 | remedial investigation   |
| 41 | RIWP               | remedial investigation work plan   |
| 42 | RL                 | reporting limit  |
| 43 | RPD                | relative percent difference  |
| 44 | RRF                | relative response factor   |
| 45 | RSD                | relative standard deviation  |
| 46 | RSL                | regional screening level   |
| 47 | RT                 | retention time   |
| 48 | SDG                | sample delivery group  |
| 49 | SIRFER             | Stable Isotope Ratio Facility for Environmental Research   |
| 50 | SOP                | standard operating procedure   |
| 51 | SRM                | standard reference material  |
| 52 | SSL                | soil screening level   |
| 53 | SVOC               | semivolatile organic compound  |

|    |           |  |
|----|-----------|--|
| 1  | TDS       | total dissolved solids   |
| 2  |           |  |
| 3  | TOC       | total organic carbon   |
| 4  | TSA       | technical system audit   |
| 5  | U         | The compound was analyzed for, but was not detected above, the reported        |
| 6  |           | method detection limit   |
| 7  | UCL       | upper control limit  |
| 8  | UDEQ      | Utah Department of Environmental Quality                                       |
| 9  | UJ        | The analyte was not detected above the reported method detection limit.        |
| 10 |           | However, the reported limit is approximate and may or may not represent the    |
| 11 |           | actual limit of quantitation necessary to accurately and precisely measure the |
| 12 |           | analyte in the sample  |
| 13 | USACE     | U.S. Army Corps of Engineers   |
| 14 | USACE CQM | U.S. Army Corps of Engineers Certified Construction Quality Manager            |
| 15 | USACE-KC  | U.S. Army Corps of Engineers, Kansas City District                             |
| 16 | USCS      | Unified Soil Classification System   |
| 17 | UT        | Utah   |
| 18 | VHA       | Veterans Health Administration   |
| 19 | VISL      | vapor intrusion screening level  |
| 20 | VOA       | volatile organic analytic  |
| 21 | VOC       | volatile organic compound  |
| 22 | ZnAc      | zinc acetate   |





# 1 Section 1

## 2 Introduction

3 This quality assurance project plan (QAPP) presents the policies, organizations, objectives, and  
4 functional activities/procedures for the remedial investigation (RI) being conducted at the 700  
5 South 1600 East PCE Plume Superfund Operable Unit 2 (OU-2) site in Salt Lake City, Utah. The  
6 QAPP is provided as part of the remedial investigation work plan (RIWP) (CH2M, 2018) and can be  
7 found in Appendix A 2 of the RIWP. The QAPP, its data quality objectives (DQOs), and its  
8 supporting document, the field sampling plan (FSP) (Appendix A 1 of the RIWP [CH2M, 2018]),  
9 were developed to document the type and quality of data needed for environmental decisions.

10 The QAPP follows U.S. Environmental Protection Agency (EPA) guidelines contained in EPA  
11 Guidance for Quality Assurance Project Plans (EPA, 2002), and EPA Requirements for Quality  
12 Assurance Project Plans (EPA, 2001, reissued 2006). The contents of the QAPP also meet the  
13 requirements of the Uniform Federal Policy for Quality Assurance Project Plans (EPA, 2005). The  
14 development, review, approval, and implementation of the QAPP is part of the EPA mandatory  
15 quality system, which requires all organizations to develop and operate management structures  
16 and processes to verify that data used in agency decisions are of the type and quality needed for  
17 their intended use. This document structure correlates with the subtitles found in EPA guidelines  
18 (EPA, 2001, 2006). This document is organized as follows:

- 19     ▪ **Section 1—Introduction.** Provides the report purpose and organization.
- 20     ▪ **Section 2—Project Management (EPA Group A).** Provides a summary-level description of  
21 the project and task organization, background and problem definition, work tasks and project  
22 schedule, quality and objectives criteria, special training and certifications, and documents  
23 and records.
- 24     ▪ **Section 3—Data Generation and Acquisition (EPA Group B).** Describes the sampling  
25 design; sampling methods; sample handling and custody; analytical methods; quality control;  
26 instrument and equipment testing, inspection and maintenance; instrument/equipment  
27 calibration and frequency; inspection/acceptance of supplies and consumables; nondirect  
28 measurements; and data management.
- 29     ▪ **Section 4—Assessment and Oversight (EPA Group C).** Describes assessment, oversight,  
30 and reports to management.
- 31     ▪ **Section 5—Data Validation and Usability (EPA Group D).** Introduces the concepts of data  
32 review, verification, and validation; describes verification and validation methods; and  
33 explains reconciliation with user requirements.
- 34     ▪ **Section 6—References.** Provides a list of references used in this document.



## Section 2

### Project Management (EPA Group A)

#### 2.1 Project/Task Organization (A4)

The Comprehensive Environmental Response Compensation and Liability Act (CERCLA) investigations at OU-2 will be conducted by CDM Smith. The investigations will be staffed with experienced personnel with proper training to provide consistent technical support for activities defined in this QAPP and the associated FSP (Appendix A-1 of the RIWP [CH2M, 2018]).

The project organization and lines of authority for CDM Smith staff are illustrated on Figure 2-1. The organizational functions and responsibilities are consistent with the overall CERCLA guidance for RI/feasibility study projects. Project team members, respective titles, and contact information are presented in Table 2-1. The team members listed in Table 2-1 will receive the approved QAPP and revisions, if any. Specific responsibilities are discussed in the following subsections.

**Table 2-1. Project Team Members**

*Quality Assurance Project Plan, OU-2 Remedial Investigation 700 South 1600 East PCE Plume, Salt Lake City, Utah*

| <b>Name</b>                | <b>Title</b>                            | <b>Location</b>                       | <b>Telephone Number</b> |
|----------------------------|---|---------------------------------------|-------------------------|
| Shannon Smith, PE          | VHA Program Manager/RPM                 | VHA, Salt Lake City, UT               | 801-582-1565, ext. 2021 |
| Susanne Fairclough         | VHA Contracts Manager                   | VHA, Salt Lake City, UT               | 801-582-1565, ext. 1952 |
| Marc Yalom                 | VHA Technical Manager                   | VHA, Salt Lake City, UT               | 801-582-1565, ext. 6603 |
| Josephine Newton-Lund, PMP | USACE Project Manager                   | USACE-KC, Kansas City, MO             | 816-289-3912            |
| Nathan Smith, PMP          | Project Manager                         | CDM Smith, Denver, CO                 | 720-264-1124            |
| Jo Nell Mullins            | Quality Assurance Manager               | CDM Smith, Knoxville, TN              | 865-963-4318            |
| Kent Sorenson, PhD, PE     | Subject Matter Expert                   | CDM Smith, Denver, CO                 | 303-383-2430            |
| Shawn Oliveira, CIH, CSP   | Safety and Health Manager               | CDM Smith, Libby, MT                  | 406-293-2672            |
| Catherine Love, GISP       | Data Manager                            | CDM Smith, Helena, MT                 | 406-441-1445            |
| Cherie Zakowski            | Project Chemist                         | CDM Smith, Denver, CO                 | 720-264-1109            |
| Neil Smith, PE             | Project Engineer                        | CDM Smith, Denver, CO                 | 303-383-2447            |
| Todd Burgesser             | HAPSITE Operator                        | CDM Smith, Denver, CO                 | 303-383-2476            |
| Raman Singh                | Analytical Laboratory Project Manager   | EMAX Laboratories, Inc., Torrance, CA | 310-618-8869, ext. 130  |
| Dan Seely, PE              | Geotechnical Laboratory Project Manager | IGES                                  | 801-270-9400            |
| Dr. Suvankar Chakraborty   | Stable Isotope Laboratory Manager       | SIRFER                                | 801-581-4654            |

Notes:

CA = California

CERCLA = Comprehensive Environmental Response  
Compensation and Liability Act

CIH = Certified Industrial Hygienist

CO = Colorado

CSP = Certified Safety Professional

GISP = Certified Geographic Information Systems Professional

IGES = Intermountain GeoEnvironmental Services, Inc.

MO = Missouri

MT = Montana

NY = New York

PE = Professional Engineer

PhD = Doctor of Philosophy

PMP = Project Management Professional

SIRFER = Stable Isotope Ratio Facility for Environmental Research

USACE = U.S. Army Corps of Engineers

USACE-KC = U.S. Army Corps of Engineers, Kansas City District

UT = Utah

VHA = Veterans Health Administration

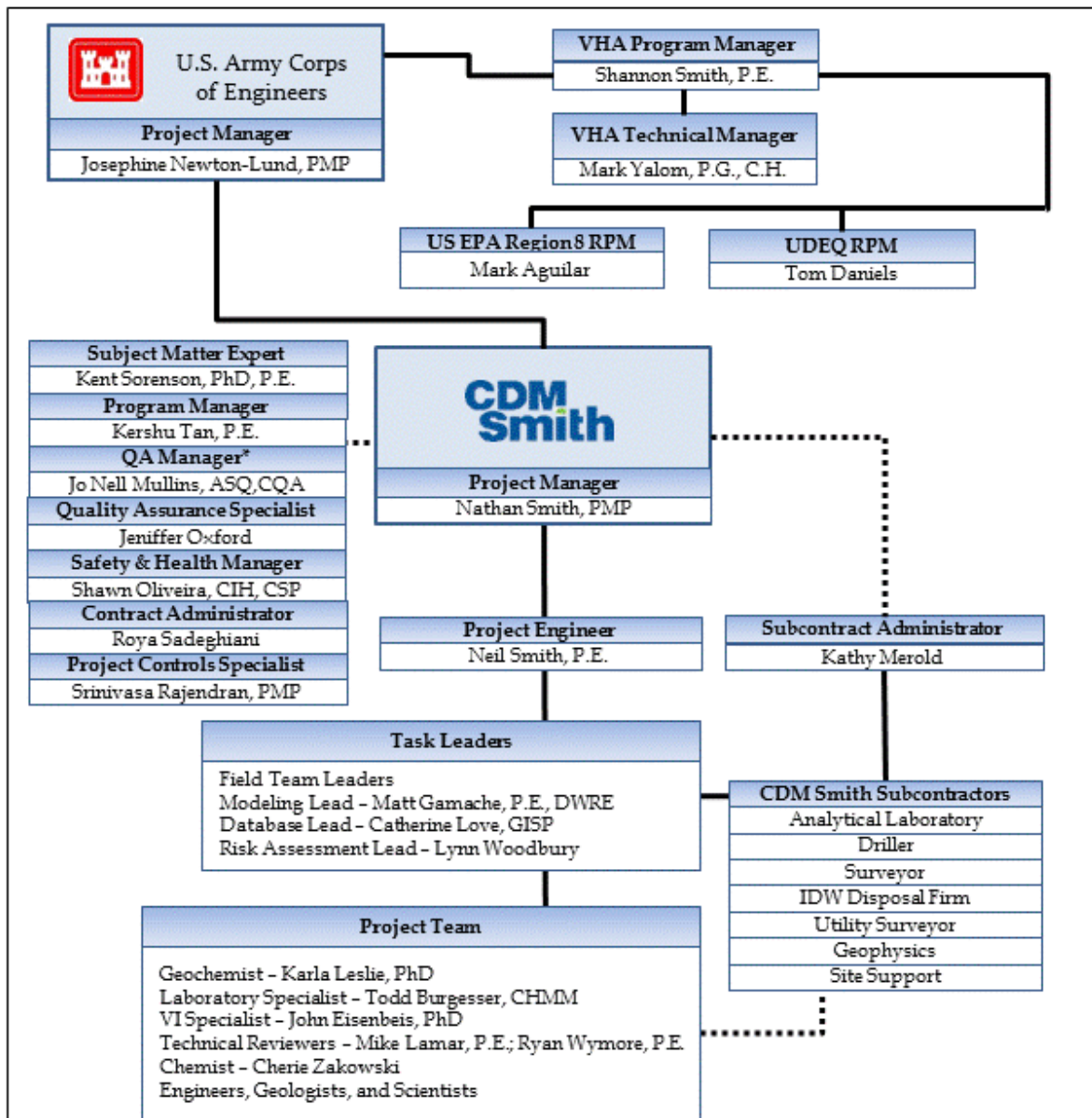

**Legend**

- = Line of Authority
- .....** = Line of Communication
- ASQ = American Society for Quality
- CERCLA = Comprehensive Environmental Response, Compensation, and Liability Act
- CH = Certified Hydrogeologist
- CHMM = Certified Hazardous Materials Manager
- CIH = Certified Industrial Hygienist
- CQA = Certified Quality Auditor
- CSP = Certified Safety Professional
- DWRE = Diplomat, Water Resource Engineer

- GISP = Geographic Information Systems Professional
- IDW = investigation-derived waste
- P.E. = Professional Engineer
- P.G. = Professional Geologist
- PhD = Doctor of Philosophy
- PMP = Project Management Professional
- RPM = remedial project manager
- TBD = to be determined
- UDEQ = Utah Department of Environmental Quality
- U.S. EPA = U.S. Environmental Protection Agency
- VHA = Veterans Health Administration



Figure 2-1  
Project Organization Chart  
VA Plume OU2

1

2

Figure 2-1. Organizational Chart

1 **2.1.1 Veterans Health Administration Program Manager**

2 Ms. Shannon Smith, as Program Manager, will serve as the Veterans Health Administration (VHA)  
3 environmental restoration manager for the OU-2 RI. The VHA will be involved in the day-to-day  
4 project delivery. Where quality assurance (QA) problems or deficiencies in this QAPP requiring  
5 special action are identified, the CDM Smith project manager, quality assurance manager (QAM),  
6 and/or the QA specialist (QAS), in conjunction with the VHA program manager, will identify the  
7 appropriate corrective action to be initiated by the field team leaders (FTLs) or the laboratory, and  
8 confirm the QAPP is amended as necessary.

9 **2.1.2 U.S. Army Corps of Engineers Project Manager**

10 Ms. Josephine Newton-Lund provides overall project management for the OU-2 RI. Ms. Newton-  
11 Lund will coordinate all project matters with VHA and CDM Smith. A multidisciplinary team will  
12 review and provide comment on written deliverables through the project manager (PM).

13 **2.1.3 Project Manager**

14 Mr. Nathan Smith will coordinate project responsibilities and financial, schedule, quality, and  
15 technical aspects of the project. The PM, in consultation with the QAM, will maintain and revise the  
16 official approved FSP, RIWP, and QAPP documents, and confirm distribution of revisions to project  
17 members.

18 **2.1.4 Quality Assurance Manager**

19 CDM Smith's quality assurance manager (QAM), Ms. Jo Nell Mullins, American Society of Quality,  
20 Certified Quality Auditor, develops the CDM Smith federal QA program and assesses its  
21 implementation on all projects. Ms. Mullins develops plans for scheduling and assessing the  
22 program via QA audits and corrective actions for deficiencies. The QAS and all QA reviewers report  
23 to the QAM.

24 **2.1.5 Subject Matter Expert**

25 Dr. Kent Sorenson, an engineer with more than 25 years of experience, will serve as the subject  
26 matter expert for groundwater characterization, identify other subject matter experts that may be  
27 required, and verify the project's compliance with current state of the science. Dr. Sorenson will  
28 serve as a technical reviewer on CDM Smith deliverables. Dr. Sorenson will also provide technical  
29 oversight and direction to the project engineer.

30 **2.1.6 Safety & Health Manager**

31 The corporate health and safety manager, Mr. Shawn Oliveira, Certified Industrial Hygienist, is  
32 responsible for implementing and maintaining the health and safety program for federal  
33 government projects at CDM Smith and for reviewing and approving the accident prevention plan  
34 governing field activities. Mr. Oliveira will be the point of contact for health and safety issues or  
35 concerns that may arise during performance of the work.

36 **2.1.7 Data Manager**

37 Ms. Catherine Love will verify that field and laboratory data are managed appropriately, maintain  
38 the field and analytical data in EQUIS, and archive data as required by the contract. She will  
39 communicate with the PM, QAS, project chemist, and field staff about any issues or problems with  
40 field or laboratory data.

1 **2.1.8 Project Chemist**

2 Ms. Cherie Zakowski will manage, coordinate, and oversee the analytical laboratories. She will also  
3 verify that laboratory data are delivered complete and are validated in compliance with the QAPP.

4 **2.1.9 Project Engineer**

5 Mr. Neil Smith will provide oversight to verify all field investigation activities performed by CDM  
6 Smith and its subcontractors comply with the requirements in the approved work planning  
7 documents. Mr. Smith will also verify that field activities meet the quality metrics outlined in the  
8 work planning documents and that appropriate QC inspections are performed and properly  
9 documented.

10 **2.1.10 Laboratory Project Managers**

11 Mr. Raman Singh (EMAX Laboratories) will act as the analytical laboratory PM. In this role, Mr.  
12 Singh will oversee laboratory analytical performance and confirm all laboratory protocols are  
13 followed to verify analytical results meet QA requirements. Mr. Singh, as the analytical laboratory  
14 PM, will manage all subcontract laboratories.

15 Intermountain GeoEnvironmental Services, Inc. has been tentatively identified as the laboratory for  
16 geotechnical analyses for soil samples collected from well borings. Dan Seely, PE, would serve as  
17 the laboratory PM. Mr. Seely would confirm that the geotechnical testing follows the procedures  
18 and QC criteria in the applicable ASTM standards.

19 The Stable Isotope Ratio Facility for Environmental Research (SIRFER) laboratory at the University  
20 of Utah will perform stable isotope analysis for water samples. Dr. Suvankar Chakraborty is the  
21 laboratory manager and will oversee laboratory work, verify that all laboratory protocols are  
22 followed, and confirm that the results meet QA requirements.

23 The PM and project chemist will communicate with the laboratory PMs to resolve problems or  
24 issues related to the laboratory analyses.

25 **2.2 Problem Definition/Background (A5)**

26 **2.2.1 Background**

27 Detailed information regarding site background can be found in Section 2 of the RIWP (CH2M,  
28 2018).

29 **2.2.2 Problem Definition**

30 The RIWP provides an evaluation of DQOs including a problem definition. The problem definition is  
31 as follows:

- 32 ■ Tetrachloroethene (PCE)-contaminated groundwater is presumed to be present beneath VHA  
33 property and is present in areas hydraulically downgradient of VHA property.  
34 PCE-contaminated groundwater was also drawn toward SLC-18 when the well was in  
35 operation. People could be exposed to the PCE-contaminated groundwater through two  
36 avenues:
- 37 ■ Existing or new water-supply wells including SLC-18, if it is brought back online

- 1     ■ The currently available information supports the conclusion that exposures to PCE-  
2     contaminated groundwater through the use of water-supply wells is controlled by Salt Lake  
3     City temporarily removing SLC-18 from service.
- 4     ■ Vapor-intrusion and direct-contact pathways associated with shallow-groundwater and  
5     springs in the East Side Springs areas (currently managed as part of Accelerated Operable  
6     Unit 1 [AOU-1])
- 7     ■ Investigations and remedies associated with shallow groundwater within AOU-1 are being  
8     addressed separately under the Federal Facilities Agreement and will be incorporated by  
9     reference into OU-2 CERCLA documents.
- 10    ■ A time-critical removal action associated with shallow groundwater within AOU-1 is being  
11    addressed under VHA removal action authority for now and will be incorporated, at a later  
12    time, into the OU-2 RI.

13    Additional data are needed to characterize the hydrogeology and nature and extent of PCE  
14    contamination, to assess potential exposure pathways and risks, and allow development and  
15    detailed analysis of remedial alternatives during the subsequent feasibility study (CH2M, 2018).

16    Section 2.4 provides information on DQOs.

## 17    2.3 Project Description (A6)

18    The tasks described in the RIWP (CH2M, 2018) reflect work that VHA will do as part of Phase 1 of  
19    the RI; Phase 2, follow-on work, will be developed after the draft interim RI Report is submitted to  
20    EPA and Utah Department of Environmental Quality (UDEQ).

### 21    2.3.1 Description of Work Tasks

22    The potential activities to be completed as part of the Phase 1 RI include the following:

- 23    ■ Collection and analysis of soil gas samples, with onsite screening-level analysis of the soil gas  
24    samples using the HAPSITE gas chromatograph/mass spectrometer (GC/MS) or a photo-  
25    ionization detector (PID) and analysis of a subset of samples at the offsite laboratory
- 26    ■ Collection and offsite analysis of soil samples, depending on the results from the soil gas  
27    samples
- 28    ■ Installation of shallow and deep groundwater wells and soil vapor probes
- 29    ■ Push-ahead groundwater sampling during deep monitoring well drilling, with onsite  
30    screening-level analysis of the groundwater samples using the HAPSITE GC/MS
- 31    ■ Collection of soil samples during well installation for geotechnical testing at an offsite  
32    laboratory
- 33    ■ Aquifer slug testing and aquifer pumping tests on monitoring wells
- 34    ■ Geophysical and groundwater flow logging within borings or wells
- 35    ■ Groundwater monitoring of new and existing monitoring wells, with collection of field  
36    parameters and analysis at offsite laboratories



- 1     ■ Surface water sampling, with collection of field parameters and analysis at offsite  
2       laboratories

3     At the completion of Phase 1 fieldwork, the data will be analyzed and remaining data gaps will be  
4     identified (if any). Phase 2 of the RI will be implemented at that time to fill these data gaps, using  
5     methods identified above or additional methods. Additional field methods described in this QAPP  
6     that may be used in subsequent phases (Phase 2 and potential follow-on phases) of the  
7     investigation include the following:

- 8     ■ Source investigation including soil gas testing, surface and near-surface soil sampling, and  
9       subsurface soil sampling
- 10    ■ Additional groundwater sampling including ongoing monitoring of existing monitoring wells  
11    and the installation and sampling of temporary groundwater sampling points installed  
12    through direct-push methods
- 13    ■ An aquifer pump test at the drinking water supply well SLC-18
- 14    ■ Cone-penetration testing
- 15    ■ Additional surface water sampling
- 16    ■ Ecological site reconnaissance
- 17    ■ Well maintenance as necessary

18    This QAPP addresses analyses that could be performed during Phase 1 and the potential tasks  
19    performed in Phase 2 of the fieldwork. In contrast, the FSP (Appendix A-1 of the RIWP [CH2M,  
20    2018]) addresses Phase 1 only, and will be updated as needed to address additional sampling after  
21    Phase 1 is complete. Analyses that could potentially be performed during Phase 2 are described in  
22    the RIWP as toolbox items in Section 5.3 of the RIWP.

### 23    **2.3.2 Project Schedule**

24    The proposed schedule for the RI field activities and associated deliverables is summarized in  
25    Figure 6-1 of the RIWP (CH2M, 2018). The PM will update the project schedule on a monthly basis,  
26    or more frequently, as needed. After the completion of the Phase 2 fieldwork, a groundwater  
27    modeling QAPP will be developed. Once the groundwater modeling QAPP is approved by the  
28    regulators, a detailed Groundwater Flow Model and Solute Transport Model will be developed  
29    using data from the Phase 1 and 2 fieldwork, supplemented with historical data as appropriate.  
30    Visualization output will be generated to capture the results of these models.

## 31    **2.4 Quality Objectives and Criteria (A7)**

### 32    **2.4.1 Project Quality Objectives**

33    Refer to Sections 2.4 and 5.1 of the RIWP for the overall project approach. Specific DQOs were  
34    considered independently through the EPA seven-step DQO process (EPA, 2006) to meet the data  
35    user's needs for each activity. Table 2-2 summarizes the OU-2 DQOs. The RIWP contains additional  
36    information regarding work activities and site details referenced in the DQOs (CH2M, 2018).

37    Reporting limits must be sufficient to achieve the objectives shown in Table 2-2. Reporting  
38    detection limits, regulatory limits, and other uses of the data were taken into consideration in

1 selecting appropriate methods and laboratory reporting limits (RLs). Volatile organic compounds  
2 (VOCs), specifically PCE, trichloroethene, cis-1,2-dichloroethene, and vinyl chloride are the  
3 currently known constituents of potential concern (COPCs). The stabilizer 1,4-dioxane (requested  
4 by EPA because of its use as stabilizer in solvents such as 1,1,1-trichloroethane) will also be  
5 monitored. Semivolatile organic compounds (SVOCs), metals, and various general water quality  
6 and natural attenuation parameters are included in the sampling plans to provide additional data  
7 for the RI. The preliminary COPCs and characterization constituents determined from the DQO  
8 process with their RL requirements are listed in Tables 2-3 through 2-13. The selected methods are  
9 state-of-the-art and appropriate for this study. For most analytes, laboratory-specific method  
10 detection limits (MDLs) are expected to be below needed detection levels listed in Tables 2-3  
11 through 2-13. Where sample-specific reporting limits are higher than needed limits, the project  
12 team will use MDLs, as needed and available, for project decisions.

13 Validated laboratory chemical data will be used. This applies to any laboratory contracted by either  
14 the U.S. Army Corps of Engineers (USACE) or the CDM Smith team to perform analyses.  
15 Laboratories must have an established program for data reduction, review, approval, and reporting  
16 as discussed following subsections.

**Table 2-2. Data Quality Objectives**

Quality Assurance Project Plan, OU-2 Remedial Investigation 700 South 1600 East PCE Plume, Salt Lake City, Utah

| Principal Study Questions   | Information Inputs  | Spatial Study Boundaries   | Analytical Approach   | Performance or Acceptance Criteria  | Plan for Obtaining Data   |
|---|---|--|---|---|---|
| <p><b>Overall Problem Statement:</b> PCE-contaminated groundwater is presumed present beneath VHA property and is present in areas hydraulically downgradient of VHA property. PCE-contaminated groundwater was also drawn toward SLC-18 when the well was in operation. People could be exposed to the PCE-contaminated groundwater through (1) existing or new water supply wells including SLC-18 if it is brought back online,<sup>a</sup> or (2) vapor intrusion and direct-contact pathways associated with shallow-groundwater and springs in the ESS area (currently being managed as part of AOU-1).<sup>b</sup> Additional data are needed to characterize the hydrogeology and nature and extent of PCE contamination, to assess potential transport and exposure pathways and risks, and to allow development and detailed analysis of remedial alternatives during the subsequent feasibility study.</p> |   |  |   |   |   |
| <p><b>Question 1:</b> What is the source(s) of PCE plume identified by the 1998 EPA monitoring wells? Is there still sufficient mass of PCE in the vadose zone to act as an ongoing source of PCE in groundwater?</p>   | <p>Historical documents and aerial photography for potential source areas</p> <p>Soil gas, soil, and groundwater VOC data</p> <p>Soil and soil gas screening levels applicable to the migration-to-groundwater pathway</p> <p>If more site-specific evaluation is needed, additional inputs could include:</p> <ul style="list-style-type: none"> <li>• Vadose zone lithological data</li> <li>• Vadose zone soil hydraulic properties data</li> <li>• Saturated zone hydraulic properties and groundwater flow data</li> <li>• Precipitation data</li> </ul> | <p>Vicinity of identified possible source areas including:</p> <ul style="list-style-type: none"> <li>• VHA Medical Center Building 7 and Sunnyside Sewer Line</li> <li>• Former Fort Douglas</li> <li>• Former Utah National Guard Vehicle Maintenance Facility</li> <li>• Former U.S. Forest Service Helicopter Pad</li> </ul> | <p>If soil gas data suggest the presence of PCE in vadose zone soil above soil gas screening levels, collect vadose zone soil samples.</p> <p>If vadose zone soil samples exceed migration-to-groundwater screening levels, evaluate whether more site-specific analysis, such as one-dimensional, numerical, unsaturated flow and transport modeling would support remedial decision making.</p> <p>If source area soil gas or soil data suggest that other pathways (soil direct exposure or vapor intrusion) could be significant, assess whether additional data are necessary to support human health risk assessment or remedial decision making.</p> | <p>Chemical analyses need to be sensitive enough for comparison to EPA soil screening levels for migration to groundwater for PCE and daughter products.</p>  | <p>Identify potential source areas based on historic records, analytical data, and aerial photos. Design source investigations to target potential source areas or areas where data are inadequate to define the nature and extent of contamination. Collect sufficient data to delineate the nature and extent of source; conduct a baseline risk assessment and develop and evaluate remedial alternatives. Methods may include:</p> <ul style="list-style-type: none"> <li>• Soil gas sampling</li> <li>• Soil sampling via GeoProbe</li> <li>• Groundwater sampling via HydroPunch or monitoring wells</li> </ul> |
| <p><b>Question 2:</b> What is the lateral and vertical extent of the PCE plume identified by the 1998 EPA monitoring wells? How far downgradient does the PCE plume extend?</p>   | <ul style="list-style-type: none"> <li>• Groundwater sampling results from existing and new wells</li> <li>• MCLs or applicable screening levels for defining the extent of contamination</li> <li>• Hydrogeological data including lithology, samples from unsaturated and saturated intervals, and water levels</li> </ul>  | <p>Proposed OU-2 RI field investigation area</p>   | <p>Based on Phase 1 groundwater monitoring results and professional judgment, consider additional groundwater sampling locations if the interpolated contours of groundwater PCE above MCLs show data gaps and too much uncertainty.</p>  | <p>Adequately spaced data (roughly 1,000 feet horizontally and 50 feet vertically) are required to delineate plume to MCLs. A network of monitoring wells is needed including: centerline wells to understand plume behavior along primary flow paths, perimeter wells to delineate and monitor plume stability, and sentinel wells to monitor for future plume expansion both horizontally and vertically. The installation of additional wells will be phased depending on available funds.</p> <p>Chemical analyses need to be sensitive enough for comparison to MCLs or applicable screening levels (Table 5-3 in the RIWP).</p> | <p>Develop a sufficient monitoring network to delineate plume horizontally and vertically and monitor plume behavior and stability. Methods will include:</p> <ul style="list-style-type: none"> <li>• Shallow and deep multi-level monitoring wells installed with sonic drilling methods</li> <li>• Groundwater sampling via low-flow sampling</li> <li>• Hydrogeological data collection including soil lithology, depths of saturated intervals, and water levels</li> </ul>  |
| <p><b>Question 3:</b> Is the PCE and daughter products measured in the ESS related to the PCE contamination plume identified by the 1998 EPA monitoring wells?</p>  | <ul style="list-style-type: none"> <li>• Groundwater sampling results from new wells upgradient of 1300 East</li> <li>• MCLs or applicable screening levels for defining the extent of contamination</li> <li>• Hydrogeological data including lithology, water levels, and sampling results</li> </ul>   | <p>Area east of 1300 East, spanning from approximately Michigan Avenue to the south and 700 South to the north</p>   | <p>Based on Phase 1 groundwater monitoring results, determine whether groundwater monitoring wells in this area contain PCE concentrations greater than the MCL or greater than the previously observed PCE concentrations in shallow groundwater west of 1300 East.</p>  | <p>Adequately spaced data are required on the east side of 1300 East, perpendicular to the assumed direction of groundwater flow. The spacing should be generally proportional to the north-south extent of groundwater contamination west of 1300 East. Chemical analyses need to be sensitive enough for comparison to MCLs or applicable screening levels (Table 5-3 in the RIWP).</p>   | <p>Develop a sufficient monitoring network across the north-south extent of the area upgradient of the known contamination on the west side of 1300 East. Methods will include:</p> <ul style="list-style-type: none"> <li>• Monitoring well installation via sonic drilling methods</li> <li>• Groundwater sampling via low-flow sampling methods</li> </ul> <p>Collect hydrogeological data including soil lithology, depths of saturated intervals, and water levels</p>   |

**Table 2-2. Data Quality Objectives**

Quality Assurance Project Plan, OU-2 Remedial Investigation 700 South 1600 East PCE Plume, Salt Lake City, Utah

| Principal Study Questions   | Information Inputs   | Spatial Study Boundaries                  | Analytical Approach  | Performance or Acceptance Criteria  | Plan for Obtaining Data  |
|---|--|---|--|---|--|
| <p><b>Overall Problem Statement:</b> PCE-contaminated groundwater is presumed present beneath VHA property and is present in areas hydraulically downgradient of VHA property. PCE-contaminated groundwater was also drawn toward SLC-18 when the well was in operation. People could be exposed to the PCE-contaminated groundwater through (1) existing or new water supply wells including SLC-18 if it is brought back online,<sup>a</sup> or (2) vapor intrusion and direct-contact pathways associated with shallow-groundwater and springs in the ESS area (currently being managed as part of AOU-1).<sup>b</sup> Additional data are needed to characterize the hydrogeology and nature and extent of PCE contamination, to assess potential transport and exposure pathways and risks, and to allow development and detailed analysis of remedial alternatives during the subsequent feasibility study.</p> |  |   |  |   |  |
| <p><b>Question 4:</b> What hydrogeological features control PCE fate and transport? If the PCE plume identified by the 1998 EPA monitoring wells extends to ESS (refer to Question 3), what factors control the plume in fault zone/hillside? Does the entire plume discharge to the hillside or does some component continue deeper to the west?</p>   | <ul style="list-style-type: none"> <li>Lithology and hydrostratigraphy data (grain size distribution, fraction organic carbon, and extent and thickness of perching layers)</li> <li>Structural geology (fault trace and orientation)</li> <li>Interpretation of borehole geophysical data from new monitoring wells</li> <li>Water levels and horizontal and vertical hydraulic gradients</li> <li>Recharge and pumping history</li> <li>Aquifer test results and estimated hydrogeological properties including transmissivity, hydraulic conductivity, storativity, and vertical and horizontal hydraulic gradients</li> <li>Geochemistry data including major ion chemistry and stable isotopes</li> <li>Previous groundwater modeling and new Phase 1 modeling</li> </ul> | Proposed OU-2 RI field investigation area | Integrate information inputs into a sitewide CSM. If professional judgment shows too much uncertainty in specific locations or regarding specific factors, additional data collection will be considered.  | Hydrogeological data collection and groundwater modeling conducted under the supervision of a qualified Utah Professional Geologist will be acceptable. | <ul style="list-style-type: none"> <li>Collect lithology and hydrostratigraphy data from new monitoring wells and assimilate information from existing wells</li> <li>Aggregate pumping history information from major Salt Lake City and University of Utah production wells</li> <li>Obtain available water level data from wells with pressure transducers.</li> <li>Collect water level data from new and existing wells</li> <li>Perform aquifer tests on selected wells to characterize hydraulic connectivity in area impacted by the PCE plume</li> <li>Collect VOC, major ion, and stable isotope data from selected wells and surface water</li> </ul> |
| <p><b>Question 5:</b> What is the nature of the hydraulic connection between the PCE plume and production wells (SLC-18, University of Utah wells, and Mount Olivet well)?</p>  | <ul style="list-style-type: none"> <li>Groundwater sampling results from existing and new wells</li> <li>Lithology and hydrostratigraphy data (grain size distribution, fraction organic carbon, and extent and thickness of perching layers)</li> <li>Structural geology (fault trace and orientation)</li> <li>Interpretation of borehole geophysical data from new monitoring wells</li> <li>Water levels and horizontal and vertical hydraulic gradients</li> <li>Recharge and pumping history</li> <li>Aquifer test results and estimated hydrogeological properties including transmissivity, hydraulic conductivity, storativity, and vertical and horizontal hydraulic gradients</li> <li>Previous groundwater modeling and new Phase 2 modeling</li> </ul>            | Area between plume and production wells   | <p>If professional judgment shows gaps in understanding the connection between the plume and production wells, additional data collection will be considered.</p> <p>Upon development of the new groundwater flow model, calibrated to aquifer property data, evaluate whether operation of nearby production wells at rates consistent with historical operations could reasonably influence groundwater flow conditions at the site.</p> | See Performance or Acceptance Criteria for Questions #2, #3, and #4.  | <p>See Plan for Obtaining Data for Questions #2, #3, and #4.</p> <p>In addition, pump testing using new monitoring wells may provide more information regarding the zone of influence of SLC-18.</p>   |

**Table 2-2. Data Quality Objectives**

Quality Assurance Project Plan, OU-2 Remedial Investigation 700 South 1600 East PCE Plume, Salt Lake City, Utah

| Principal Study Questions   | Information Inputs   | Spatial Study Boundaries  | Analytical Approach  | Performance or Acceptance Criteria   | Plan for Obtaining Data   |
|---|--|---|--|--|---|
| <p><b>Overall Problem Statement:</b> PCE-contaminated groundwater is presumed present beneath VHA property and is present in areas hydraulically downgradient of VHA property. PCE-contaminated groundwater was also drawn toward SLC-18 when the well was in operation. People could be exposed to the PCE-contaminated groundwater through (1) existing or new water supply wells including SLC-18 if it is brought back online,<sup>a</sup> or (2) vapor intrusion and direct-contact pathways associated with shallow-groundwater and springs in the ESS area (currently being managed as part of AOU-1).<sup>b</sup> Additional data are needed to characterize the hydrogeology and nature and extent of PCE contamination, to assess potential transport and exposure pathways and risks, and to allow development and detailed analysis of remedial alternatives during the subsequent feasibility study.</p> |  |   |  |  |   |
| <p><b>Question 6:</b> Besides vapor intrusion in AOU-1, drinking water wells, or potential source-area soil and soil gas, are there other potential human or ecological exposure pathways?</p>  | <p>Water sampling results from selected areas of Red Butte Creek</p>   | <p>Red Butte Creek sampling locations, in the area where surface water has previously shown to be impacted by PCE, springs are present, and where Red Butte Creek is accessible at ground surface</p> | <p>Evaluate the overall site CSM to assess whether surface water exposure pathways could exist, and, if so, consider additional surface water data collection.</p> | <p>Chemical analyses need to be sensitive enough to determine whether surface water in Red Butte Creek has been impacted by the PCE identified by the EPA monitoring wells. For these purposes, chemical analyses need to be sensitive enough for comparison to MCLs or applicable screening levels (Table 5-3 in the RIWP).</p> | <p>Collect sufficient data to support human-health risk assessment related to OU-2 surface water. Methods could include:</p> <ul style="list-style-type: none"> <li>Collection of surface water samples in Red Butte Creek</li> </ul>   |
| <p><b>Question 7:</b> Collect data to support possible remedial technologies, including MNA, hydraulic containment, and bioremediation. Determine which natural attenuation processes are operating, and estimate the rate of degradation of PCE and daughter products formed.</p>  | <ul style="list-style-type: none"> <li>See Information Inputs for source area(s) and nature and extent of contamination in Questions #1, #2, and #3</li> <li>See Information Inputs for geotechnical and hydrogeological data in Questions #2, #3, and #4</li> <li>PCE daughter product concentrations and concentration time-series</li> <li>Reduction/oxidation geochemical data</li> <li>Data supporting evaluation of natural attenuation</li> <li>Biological data supporting the assessment of reductive dechlorination</li> <li>Data supporting evaluation of potential remedial technologies</li> </ul> | <p>Entire project area</p>  | <p>Evaluate data to assess potential remedial technologies, including the occurrence of natural attenuation processes and estimated degradation rates.</p>         | <p>See Performance or Acceptance Criteria for Questions #1 through #5.</p> <p>In addition, a wide variety of definitive quantitative data and qualitative data are required to build lines of evidence for natural attenuation, as required by EPA MNA guidance.</p>   | <p>Collect data regarding source area(s) and nature and extent of contamination, as summarized in Questions #1, #2, and #3</p> <p>Collect geotechnical and geophysical data, as summarized in Questions #4 and #5</p> <p>Collect data supporting evaluation of biological and abiotic attenuation processes. Methods may include:</p> <ul style="list-style-type: none"> <li>PCE daughter product concentrations</li> <li>Dissolved oxygen measurements</li> <li>Oxidation-reduction potential measurements</li> <li>Sulfate/sulfide, ferrous iron, concentrations of dissolved gases</li> <li>Compound specific isotope analyses</li> <li>Magnetic susceptibility tests</li> </ul> |

<sup>a</sup> The currently available information supports the conclusion that exposures to PCE-contaminated groundwater through the use of water-supply wells is controlled by Salt Lake City temporarily removing SLC-18 from service.

<sup>b</sup> Investigations, removal actions, and remedies associated with shallow groundwater within AOU-1 are being addressed separately under the FFA and will be incorporated by reference into OU-2 CERCLA documents.

Notes:

AOU = Accelerated Operable Unit

CERCLA = Comprehensive Environmental Response Compensation and Liability Act

CSM = conceptual site model

EPA = U.S. Environmental Protection Agency

ESS = East Side Springs

FFA = Federal Facilities Agreement

MCL = maximum contaminant level

MNA = monitored natural attenuation

OU = operable unit

PCE = tetrachloroethene

RI = remedial investigation

RIWP = remedial investigation work plan

VHA = Veterans Health Administration

VOC = volatile organic compound



**Table 2-3. Project Laboratory (EMAX Laboratories, Inc.)– Target Analytes and Reporting Limits – Volatile Organic Compounds in Soil**

*Quality Assurance Project Plan, OU-2 Remedial Investigation 700 South 1600 East PCE Plume, Salt Lake City, Utah*

| Analyte   | CAS Number | Method     | Screening Level                            | Lowest Screening Level Value (mg/kg) <sup>a</sup> | Lab RL (mg/kg) |
|---|------------|------------|--|---|----------------|
| 1,1,1-Trichloroethane                             | 71-55-6    | SW8260C    | Protection of Groundwater MCL-SSL (DAF=20) | 1.4   | 0.005          |
| 1,1,2,2-Tetrachloroethane                         | 79-34-5    | SW8260C    | Protection of Groundwater SSL (DAF=20)     | 0.0006 <sup>b</sup>                               | 0.005          |
| 1,1,2-Trichloro-1,2,2-trifluoroethane (Freon 113) | 76-13-1    | SW8260C    | Protection of Groundwater SSL (DAF=20)     | 52  | 0.005          |
| 1,1,2-Trichloroethane                             | 79-00-5    | SW8260C    | Protection of Groundwater SSL (DAF=20)     | 0.00026 <sup>b</sup>                              | 0.005          |
| 1,1-Dichloroethane                                | 75-34-3    | SW8260C    | Protection of Groundwater SSL (DAF=20)     | 0.016   | 0.005          |
| 1,1-Dichloroethene                                | 75-35-4    | SW8260C    | Protection of Groundwater MCL-SSL (DAF=20) | 0.05  | 0.005          |
| 1,2,3-Trichlorobenzene                            | 87-61-6    | SW8260C    | Protection of Groundwater SSL (DAF=20)     | 0.042   | 0.005          |
| 1,2,4-Trichlorobenzene                            | 120-82-1   | SW8260C    | Protection of Groundwater SSL (DAF=20)     | 0.024   | 0.005          |
| 1,2,4-Trimethylbenzene                            | 95-63-6    | SW8260C    | Protection of Groundwater SSL (DAF=20)     | 0.042   | 0.005          |
| 1,3,5-Trimethylbenzene                            | 108-67-8   | SW8260C    | Protection of Groundwater SSL (DAF=20)     | 0.34  | 0.005          |
| 1,2-Dibromo-3-Chloropropane                       | 96-12-8    | SW8260C    | Protection of Groundwater SSL (DAF=20)     | 0.0000028 <sup>b</sup>                            | 0.005          |
| 1,2-Dibromoethane (EDB)                           | 106-93-4   | SW8260C    | Protection of Groundwater SSL (DAF=20)     | 0.000042 <sup>b</sup>                             | 0.005          |
| 1,2-Dichlorobenzene                               | 95-50-1    | SW8260C    | Protection of Groundwater SSL (DAF=20)     | 0.6   | 0.005          |
| 1,2-Dichloroethane                                | 107-06-2   | SW8260C    | Protection of Groundwater SSL (DAF=20)     | 0.00096 <sup>b</sup>                              | 0.005          |
| 1,2-Dichloropropane                               | 78-87-5    | SW8260C    | Protection of Groundwater SSL (DAF=20)     | 0.0054  | 0.005          |
| 1,3-Dichlorobenzene                               | 541-73-1   | SW8260C    | --   | NA  | 0.005          |
| 1,4-Dichlorobenzene                               | 106-46-7   | SW8260C    | Protection of Groundwater SSL (DAF=20)     | 0.0092  | 0.005          |
| 1,4-Dioxane                                       | 123-91-1   | SW8260BSIM | Protection of Groundwater SSL (DAF=20)     | 0.0019 <sup>b</sup>                               | 0.005          |
| 2-Butanone (Methyl Ethyl Ketone)                  | 78-93-3    | SW8260C    | Protection of Groundwater SSL (DAF=20)     | 2.4   | 0.01           |
| 2-Hexanone  | 591-78-6   | SW8260C    | Protection of Groundwater SSL (DAF=20)     | 0.018   | 0.01           |
| 4-Methyl-2-pentanone                              | 108-10-1   | SW8260C    | Protection of Groundwater SSL (DAF=20)     | 2.8   | 0.01           |
| Acetone   | 67-64-1    | SW8260C    | Protection of Groundwater SSL (DAF=20)     | 5.8   | 0.01           |

**Table 2-3. Project Laboratory (EMAX Laboratories, Inc.)– Target Analytes and Reporting Limits – Volatile Organic Compounds in Soil**

*Quality Assurance Project Plan, OU-2 Remedial Investigation 700 South 1600 East PCE Plume, Salt Lake City, Utah*

| <b>Analyte</b>                     | <b>CAS Number</b>     | <b>Method</b> | <b>Screening Level</b>                     | <b>Lowest Screening Level Value (mg/kg)<sup>a</sup></b> | <b>Lab RL (mg/kg)</b> |
|------------------------------------|-----------------------|---------------|--|---|-----------------------|
| Benzene                            | 71-43-2               | SW8260C       | Protection of Groundwater SSL (DAF=20)     | 0.0046 <sup>b</sup>                                     | 0.005                 |
| Bromochloromethane                 | 74-97-5               | SW8260C       | Protection of Groundwater SSL (DAF=20)     | 0.042   | 0.005                 |
| Bromodichloromethane               | 75-27-4               | SW8260C       | Protection of Groundwater SSL (DAF=20)     | 0.00072 <sup>b</sup>                                    | 0.005                 |
| Bromoform                          | 75-25-2               | SW8260C       | Protection of Groundwater SSL (DAF=20)     | 0.017   | 0.005                 |
| Bromomethane                       | 74-83-9               | SW8260C       | Protection of Groundwater SSL (DAF=20)     | 0.0038 <sup>b</sup>                                     | 0.01                  |
| Carbon Disulfide                   | 75-15-0               | SW8260C       | Protection of Groundwater SSL (DAF=20)     | 0.48  | 0.005                 |
| Carbon Tetrachloride               | 56-23-5               | SW8260C       | Protection of Groundwater SSL (DAF=20)     | 0.0036 <sup>b</sup>                                     | 0.005                 |
| Chlorobenzene                      | 108-90-7              | SW8260C       | Protection of Groundwater SSL (DAF=20)     | 0.11  | 0.005                 |
| Chloroethane                       | 75-00-3               | SW8260C       | Protection of Groundwater SSL (DAF=20)     | 12  | 0.005                 |
| Chloroform                         | 67-66-3               | SW8260C       | Protection of Groundwater SSL (DAF=20)     | 0.0012 <sup>b</sup>                                     | 0.005                 |
| Chloromethane                      | 74-87-3               | SW8260C       | Protection of Groundwater SSL (DAF=20)     | 0.098   | 0.005                 |
| cis-1,2-Dichloroethene             | 156-59-2              | SW8260C       | Protection of Groundwater SSL (DAF=20)     | 0.022   | 0.005                 |
| Dibromochloromethane               | 124-48-1              | SW8260C       | Protection of Groundwater SSL (DAF=20)     | 0.0046 <sup>b</sup>                                     | 0.005                 |
| Dichlorodifluoromethane (Freon 12) | 75-71-8               | SW8260C       | Protection of Groundwater SSL (DAF=20)     | 0.6   | 0.005                 |
| Ethylbenzene                       | 100-41-4              | SW8260C       | Protection of Groundwater SSL (DAF=20)     | 0.034   | 0.005                 |
| Isopropylbenzene (Cumene)          | 98-82-8               | SW8260C       | Protection of Groundwater SSL (DAF=20)     | 1.5   | 0.005                 |
| Methyl acetate                     | 79-20-9               | SW8260C       | Protection of Groundwater SSL (DAF=20)     | 8.2   | 0.005                 |
| Methyl Tert-Butyl Ether            | 1634-04-4             | SW8260C       | Protection of Groundwater SSL (DAF=20)     | 0.064   | 0.005                 |
| Methylene chloride                 | 75-09-2               | SW8260C       | Protection of Groundwater MCL-SSL (DAF=20) | 0.026   | 0.01                  |
| m,p-Xylene                         | 108-38-3 and 106-42-3 | SW8260C       | Protection of Groundwater SSL (DAF=20)     | 0.38  | 0.01                  |
| o-Xylene                           | 95-47-6               | SW8260C       | Protection of Groundwater SSL (DAF=20)     | 0.38  | 0.005                 |
| Styrene                            | 100-42-5              | SW8260C       | Protection of Groundwater MCL-SSL (DAF=20) | 2.2   | 0.005                 |



**Table 2-3. Project Laboratory (EMAX Laboratories, Inc.)– Target Analytes and Reporting Limits – Volatile Organic Compounds in Soil**

*Quality Assurance Project Plan, OU-2 Remedial Investigation 700 South 1600 East PCE Plume, Salt Lake City, Utah*

| Analyte                                      | CAS Number | Method  | Screening Level                            | Lowest Screening Level Value (mg/kg) <sup>a</sup> | Lab RL (mg/kg) |
|--|------------|---------|--|---|----------------|
| Tetrachloroethene                            | 127-18-4   | SW8260C | Protection of Groundwater MCL-SSL (DAF=20) | 0.036   | 0.005          |
| Toluene                                      | 108-88-3   | SW8260C | Protection of Groundwater SSL (DAF=20)     | 1.5   | 0.005          |
| Total 1,3-dichloro propene (cis- and trans-) | 542-75-6   | SW8260C | Protection of Groundwater SSL (DAF=20)     | 0.0034 <sup>b</sup>                               | 0.005          |
| trans-1,2-Dichloroethene                     | 156-60-5   | SW8260C | Protection of Groundwater SSL (DAF=20)     | 0.22  | 0.005          |
| Trichloroethene                              | 79-01-6    | SW8260C | Protection of Groundwater SSL (DAF=20)     | 0.002 <sup>b</sup>                                | 0.005          |
| Trichlorofluoromethane (Freon 11)            | 75-69-4    | SW8260C | Protection of Groundwater SSL (DAF=20)     | 6.6   | 0.005          |
| Vinyl Acetate                                | 108-05-4   | SW8260C | Protection of Groundwater SSL (DAF=20)     | 0.17  | 0.005          |
| Vinyl Chloride                               | 75-01-4    | SW8260C | Protection of Groundwater SSL (DAF=20)     | 0.00013 <sup>b</sup>                              | 0.005          |

<sup>a</sup> Lowest of: (1) RSLs for residential exposure, (2) SSLs for groundwater protection using a DAF of 20, and Soil Saturation Level. RSLs corresponding to an excess lifetime cancer risk of  $1 \times 10^{-6}$  and a hazard quotient of 0.1 were used (November 2017).

<sup>b</sup> Due to the low screening level for this analyte, the RL is greater than the screening level. However, soil screening would be used in a source investigation in which the RL would be an acceptable limit.

Notes:

CAS = Chemical Abstracts Service

DAF = dilution attenuation factor

MCL = maximum contaminant level

mg/kg = milligram(s) per kilogram

RL = reporting limit

RSL = regional screening level

SSL = soil screening level

**Table 2-5. Project Laboratory (EMAX Laboratories, Inc.) – Target Analytes and Reporting Limits – Metals in Soil**  
*Quality Assurance Project Plan, OU-2 Remedial Investigation 700 South 1600 East PCE Plume, Salt Lake City, Utah*

| Analyte   | CAS Number | Method  | Screening Level                            | Lowest Screening Level Value (mg/kg) <sup>a</sup> | Lab RL (mg/kg) |
|-----------|------------|---------|--|---|----------------|
| Aluminum  | 7429-90-5  | SW6020A | EPA RSL                                    | 7,700   | 100            |
| Antimony  | 7440-36-0  | SW6020A | Protection of Groundwater SSL (DAF=20)     | 0.7   | 0.5            |
| Arsenic   | 7440-38-2  | SW6020A | Protection of Groundwater SSL (DAF=20)     | 0.03 <sup>b</sup>                                 | 0.5            |
| Barium    | 7440-39-3  | SW6020A | EPA RSL                                    | 320   | 2              |
| Beryllium | 7440-41-7  | SW6020A | EPA RSL                                    | 16  | 0.5            |
| Cadmium   | 7440-43-9  | SW6020A | Protection of Groundwater SSL (DAF=20)     | 1.4   | 0.5            |
| Calcium   | 7440-70-2  | SW6020A | --   | NA  | 250            |
| Chromium  | 7440-47-3  | SW6020A | Protection of Groundwater MCL-SSL (DAF=20) | 3,600,000   | 0.5            |
| Cobalt    | 7440-48-4  | SW6020A | EPA RSL                                    | 0.54 <sup>b</sup>                                 | 0.625          |
| Copper    | 7440-50-8  | SW6020A | Protection of Groundwater SSL (DAF=20)     | 56  | 0.5            |
| Iron      | 7439-89-6  | SW6020A | Protection of Groundwater SSL (DAF=20)     | 700   | 100            |
| Lead      | 7439-92-1  | SW6020A | Protection of Groundwater MCL-SSL (DAF=20) | 280   | 0.5            |
| Magnesium | 7439-95-4  | SW6020A | --   | NA  | 250            |
| Manganese | 7439-96-5  | SW6020A | Protection of Groundwater SSL (DAF=20)     | 56  | 0.75           |
| Mercury   | 7487-94-7  | SW7471A | Protection of Groundwater SSL (DAF=20)     | 2.3   | 0.1            |
| Nickel    | 7440-02-0  | SW6020A | Protection of Groundwater SSL (DAF=20)     | 52  | 0.5            |
| Potassium | 7440-09-7  | SW6020A | --   | NA  | 250            |
| Selenium  | 7782-49-2  | SW6020A | Protection of Groundwater MCL-SSL (DAF=20) | 1.0   | 0.5            |
| Silver    | 7440-22-4  | SW6020A | Protection of Groundwater SSL (DAF=20)     | 1.6   | 0.5            |
| Sodium    | 7440-23-5  | SW6020A | --   | NA  | 250            |
| Thallium  | 7440-28-0  | SW6020A | Protection of Groundwater SSL (DAF=20)     | 0.028 <sup>b</sup>                                | 0.5            |
| Vanadium  | 7440-62-2  | SW6020A | EPA RSL                                    | 39  | 0.625          |
| Zinc      | 7440-66-6  | SW6020A | Protection of Groundwater SSL (DAF=20)     | 740   | 2              |

<sup>a</sup> Lowest of: (1) RSLs for residential exposure, or (2) SSLs for groundwater protection using a DAF of 20, and Soil Saturation Level. RSLs corresponding to an excess lifetime cancer risk of  $1 \times 10^{-6}$  and a hazard quotient of 0.1 were used (November 2017).

<sup>b</sup> Due to the low screening level for this analyte, the RL is greater than the screening level. However, this analyte is not a known constituent of potential concern for the site.

Notes:

CAS = Chemical Abstracts Service

DAF = dilution attenuation factor

EPA = U.S. Environmental Protection Agency

MCL = maximum contaminant level

mg/kg = milligram(s) per kilogram

NA = not applicable

RL = reporting limit

RSL = regional screening level

SSL = soil screening level

**Table 2-7. Project Laboratory (IGES, Microbial Insights, and McCampbell Analytical, Inc.) – Target Analytes and Reporting Limits – Geotechnical and Geochemical Parameters in Soil**  
*Quality Assurance Project Plan, OU-2 Remedial Investigation 700 South 1600 East PCE Plume, Salt Lake City, Utah*

| Analyte                  | CAS Number | Method                               | Screening Level | Lowest Screening Level Value (mg/kg) | Lab RL                                |
|--------------------------|------------|--------------------------------------|-----------------|--------------------------------------|---------------------------------------|
| FOC                      | NA         | ASTM D2974                           | --              | NA                                   | 0.1 %                                 |
| Magnetic Susceptibility  | NA         | Microbial Insights Laboratory Method | --              | NA                                   | $1 \times 10^{-9}$ m <sup>3</sup> /kg |
| Ferrous Iron Minerals    | NA         | SM3500-Fe B4c                        | --              | NA                                   | 1 mg/kg                               |
| Sieve Analysis           | NA         | ASTM D6913                           | --              | NA                                   | NA                                    |
| Dry Bulk Soil Density    | NA         | ASTM D2937                           | --              | NA                                   | NA                                    |
| Hydrometer               | NA         | ASTM D422a                           | --              | NA                                   | NA                                    |
| USCS Soil Classification | NA         | ASTM D2487                           | --              | NA                                   | NA                                    |
| Atterberg Limits         | NA         | ASTM D4318                           | --              | NA                                   | NA                                    |
| Gradation                | NA         | ASTM D1140                           | --              | NA                                   | NA                                    |
| Vertical Permeability    | NA         | ASTM D2434                           | --              | NA                                   | NA                                    |
| Moisture Content         | NA         | ASTM D2216                           | --              | NA                                   | NA                                    |

Notes:

CAS = Chemical Abstracts Service  
 FOC = fraction of organic carbon  
 m<sup>3</sup>/kg = cubic meter(s) per kilogram  
 mg/kg = milligram(s) per kilogram  
 NA = not applicable  
 RL = reporting limit  
 USCS = Unified Soil Classification System

Table 2-8. Project Laboratory (EMAX Laboratories, Inc.) – Target Analytes and Reporting Limits – Volatile Organic Compounds in Soil Gas

Quality Assurance Project Plan, OU-2 Remedial Investigation 700 South 1600 East PCE Plume, Salt Lake City, Utah

| Analyte   | CAS Number | Soil Gas Method | Screening Level <sup>a</sup> | Lowest Screening Level Value (µg/m <sup>3</sup> ) <sup>a</sup> | Lab RL (µg/m <sup>3</sup> ) |
|---|------------|-----------------|------------------------------|--|-----------------------------|
| <b>Laboratory Analytical Parameters</b>           |            |                 |                              |  |                             |
| 1,1,1-Trichloroethane                             | 71-55-6    | TO-15           | VISL                         | 17,000   | 1.64                        |
| 1,1,2,2-Tetrachloroethane                         | 79-34-5    | TO-15           | VISL                         | 1.6 <sup>b</sup>   | 2.75                        |
| 1,1,2-Trichloroethane                             | 79-00-5    | TO-15           | VISL                         | 0.7 <sup>b</sup>   | 2.18                        |
| 1,1,2-Trichloro-1,2,2-trifluoroethane (Freon 113) | 76-13-1    | TO-15           | VISL                         | 10,000   | 3.07                        |
| 1,1-Dichloroethane                                | 75-34-3    | TO-15           | VISL                         | 60   | 1.21                        |
| 1,1-Dichloroethene                                | 75-35-4    | TO-15           | VISL                         | 700  | 3.17                        |
| 1,2,4-Trimethylbenzene                            | 95-63-6    | TO-15           | VISL                         | 24   | 3.93                        |
| 1,2-Dibromoethane                                 | 106-93-4   | TO-15           | VISL                         | 0.16 <sup>b</sup>  | 6.15                        |
| 1,2-Dichlorobenzene                               | 95-50-1    | TO-15           | VISL                         | 700  | 2.40                        |
| 1,2-Dichloroethane                                | 107-06-2   | TO-15           | VISL                         | 3.7  | 3.24                        |
| 1,2-Dichloropropane                               | 78-87-5    | TO-15           | VISL                         | 9.3  | 1.85                        |
| 1,2-Dichlorotetrafluoroethane (Freon 114)         | 76-14-2    | TO-15           | --                           | NA   | 0.400                       |
| 1,3,5-Trimethylbenzene                            | 108-67-8   | TO-15           | VISL                         | 85,000   | 1.97                        |
| 1,3-Butadiene                                     | 106-99-0   | TO-15           | VISL                         | 3.1 <sup>b</sup>   | 21.3                        |
| 1,3-Dichlorobenzene                               | 541-73-1   | TO-15           | --                           | NA   | 2.40                        |
| 1,4-Dichlorobenzene                               | 106-46-7   | TO-15           | VISL                         | 8.7  | 2.40                        |
| 1,4-Dioxane                                       | 123-91-1   | TO-15           | VISL                         | 1.8 <sup>c</sup>   | 2.88                        |
| 2-Butanone (Methyl Ethyl Ketone)                  | 78-93-3    | TO-15           | VISL                         | 17,000   | 2.36                        |
| 2-Hexanone  | 591-78-6   | TO-15           | VISL                         | 100  | 1.64                        |
| 4-Ethyltoluene                                    | 622-96-8   | TO-15           | VISL                         | --   | 1.97                        |
| 4-Methyl-2-pentanone                              | 108-10-1   | TO-15           | VISL                         | 10,000   | 1.64                        |
| Acetone   | 67-64-1    | TO-15           | VISL                         | 41,000   | 11.9                        |
| Benzene   | 71-43-2    | TO-15           | VISL                         | 12   | 1.28                        |
| Bromodichloromethane                              | 75-27-4    | TO-15           | VISL                         | 2.5  | 2.01                        |
| Bromoform   | 75-25-2    | TO-15           | VISL                         | 87   | 4.13                        |
| Bromomethane                                      | 74-83-9    | TO-15           | VISL                         | 17   | 3.11                        |
| Carbon disulfide                                  | 75-15-0    | TO-15           | VISL                         | 2400   | 2.49                        |
| Carbon tetrachloride                              | 56-23-5    | TO-15           | VISL                         | 16   | 5.03                        |
| Chlorobenzene                                     | 108-90-7   | TO-15           | VISL                         | 170  | 1.38                        |
| Chloroethane                                      | 75-00-3    | TO-15           | VISL                         | 33,000   | 2.11                        |
| Chloroform  | 67-66-3    | TO-15           | VISL                         | 4  | 1.46                        |
| Chloromethane                                     | 74-87-3    | TO-15           | VISL                         | 310  | 1.65                        |
| cis-1,2-Dichloroethene                            | 156-59-2   | TO-15           | VISL                         | 12,000   | 1.59                        |
| cis-1,3-Dichloropropene                           | 542-75-6   | TO-15           | VISL                         | 23   | 1.82                        |
| Cyclohexane                                       | 110-82-7   | TO-15           | VISL                         | 21,000   | 2.5                         |
| Dibromochloromethane                              | 124-48-1   | TO-15           | VISL                         | 550  | 3.41                        |

**Table 2-8. Project Laboratory (EMAX Laboratories, Inc.) – Target Analytes and Reporting Limits – Volatile Organic Compounds in Soil Gas**

*Quality Assurance Project Plan, OU-2 Remedial Investigation 700 South 1600 East PCE Plume, Salt Lake City, Utah*

| Analyte                            | CAS Number               | Soil Gas Method | Screening Level <sup>a</sup> | Lowest Screening                              |                             |
|------------------------------------|--------------------------|-----------------|------------------------------|---|-----------------------------|
|                                    |                          |                 |                              | Level Value (µg/m <sup>3</sup> ) <sup>a</sup> | Lab RL (µg/m <sup>3</sup> ) |
| Dichlorodifluoromethane (Freon 12) | 75-71-8                  | TO-15           | VISL                         | 330   | 1.98                        |
| Ethyl Acetate                      | 141-78-6                 | TO-15           | VISL                         | 240   | 2.5                         |
| Ethylbenzene                       | 100-41-4                 | TO-15           | VISL                         | 37  | 1.74                        |
| n-Heptane                          | 142-82-5                 | TO-15           | VISL                         | --  | 3.28                        |
| n-Hexane                           | 110-54-3                 | TO-15           | VISL                         | 2,400   | 2.82                        |
| m,p-Xylene                         | 108-38-3<br>and 106-42-3 | TO-15           | VISL                         | 330   | 3.47                        |
| Methylene Chloride                 | 75-09-2                  | TO-15           | VISL                         | 2,100   | 1.39                        |
| Methyl tert-butyl ether            | 1634-04-4                | TO-15           | VISL                         | 370   | 2.88                        |
| o-Xylene                           | 95-47-6                  | TO-15           | VISL                         | 330   | 1.74                        |
| Styrene                            | 100-42-5                 | TO-15           | VISL                         | 33,000  | 1.70                        |
| Tetrachloroethene                  | 127-18-4                 | TO-15           | VISL                         | 140   | 2.71                        |
| Tetrahydrofuran                    | 109-99-9                 | TO-15           | VISL                         | 7,000   | 2.36                        |
| Toluene                            | 108-88-3                 | TO-15           | VISL                         | 17,000  | 1.51                        |
| trans-1,2-Dichloroethene           | 156-60-5                 | TO-15           | VISL                         | 270,000                                       | 1.59                        |
| trans-1,3-Dichloropropene          | 542-75-6                 | TO-15           | VISL                         | 23  | 1.82                        |
| Trichloroethene                    | 79-01-6                  | TO-15           | VISL                         | 7   | 2.15                        |
| Trichlorofluoromethane (Freon 11)  | 75-69-4                  | TO-15           | VISL                         | 41,000,000                                    | 2.25                        |
| Vinyl Acetate                      | 108-05-4                 | TO-15           | VISL                         | 700   | 13                          |
| Vinyl Chloride                     | 75-01-4                  | TO-15           | VISL                         | 5.7   | 1.3                         |
| <b>Field Screening Parameters</b>  |                          |                 |                              |   |                             |
| cis-1,2-Dichloroethene             | 156-59-2                 | HAPSITE         | SGSL <sub>pgw</sub>          | 120,000                                       | 2.0                         |
| Tetrachloroethene                  | 127-18-4                 | HAPSITE         | VISL                         | 140   | 0.69                        |
| Trichloroethene                    | 79-01-6                  | HAPSITE         | VISL                         | 7   | 0.55                        |

<sup>a</sup> Residential VISLs using an attenuation factor of 0.1. VISLs corresponding to an excessive lifetime cancer risk of 1E-06 and a hazard quotient of 0.1 were used.

<sup>b</sup> Due to the low screening level for this analyte, the RL is greater than the screening level. However, this analyte is not a known COPC for the site.

<sup>c</sup> Due to the low screening level for this analyte, the RL is greater than the screening level. However, this analyte is not a known COPC for the site. The low VISL for 1,4-dioxane is based on protection of groundwater quality and was derived using conservative, default, simplifying assumptions, as described in Section 5.2.1 of the remedial investigation work plan. Soil gas screening would be used in a source investigation in which the RL would be an acceptable limit.

Notes:

µg/m<sup>3</sup> = microgram(s) per cubic meter

COPC = constituent of potential concern

RL= reporting limit

SGSL<sub>pgw</sub> = soil gas equilibrium concentration - protection of groundwater

VISL = vapor intrusion screening level

Table 2-9. Project Laboratory (EMAX Laboratories, Inc.)– Target Analytes and Reporting Limits – Volatile Organic Compounds in Water (Groundwater/Surface Water)

Quality Assurance Project Plan, OU-2 Remedial Investigation 700 South 1600 East PCE Plume, Salt Lake City, Utah

| Analyte   | CAS Number | Method  | Screening Level | Screening Level Value (µg/L) <sup>a</sup> | Lab RL (µg/L) |
|---|------------|---------|-----------------|---|---------------|
| <b>Laboratory Analytical Parameters</b>           |            |         |                 |   |               |
| 1,1,1-Trichloroethane                             | 71-55-6    | SW8260C | EPA MCL         | 200                                       | 1.00          |
| 1,1,2,2-Tetrachloroethane                         | 79-34-5    | SW8260C | EPA RSL         | 0.076 <sup>b</sup>                        | 1.00          |
| 1,1,2-Trichloro-1,2,2-trifluoroethane (Freon 113) | 76-13-1    | SW8260C | EPA RSL         | 1,000                                     | 1.00          |
| 1,1,2-Trichloroethane                             | 79-00-5    | SW8260C | EPA MCL         | 5   | 1.00          |
| 1,1-Dichloroethane                                | 75-34-3    | SW8260C | EPA RSL         | 2.8                                       | 1.00          |
| 1,1-Dichloroethene                                | 75-35-4    | SW8260C | EPA MCL         | 7   | 1.00          |
| 1,2,3-Trichlorobenzene                            | 87-61-6    | SW8260C | EPA RSL         | 0.7 <sup>b</sup>                          | 1.00          |
| 1,2,4-Trichlorobenzene                            | 120-82-1   | SW8260C | EPA MCL         | 70  | 1.00          |
| 1,2,4-Trimethylbenzene                            | 95-63-6    | SW8260C | EPA RSL         | 1.5                                       | 1.00          |
| 1,3,5-Trimethylbenzene                            | 108-67-8   | SW8260C | EPA RSL         | 12  | 1.00          |
| 1,2-Dibromo-3-Chloropropane                       | 96-12-8    | SW8260C | EPA MCL         | 0.2 <sup>b</sup>                          | 2.00          |
| 1,2-Dibromoethane                                 | 106-93-4   | SW8260C | EPA MCL         | 0.05 <sup>b</sup>                         | 1.00          |
| 1,2-Dichlorobenzene                               | 95-50-1    | SW8260C | EPA MCL         | 600                                       | 1.00          |
| 1,2-Dichloroethane                                | 107-06-2   | SW8260C | EPA MCL         | 5   | 1.00          |
| 1,2-Dichloropropane                               | 78-87-5    | SW8260C | EPA MCL         | 5   | 1.00          |
| 1,3-Dichlorobenzene                               | 541-73-1   | SW8260C | --              | NA  | 1.00          |
| 1,4-Dichlorobenzene                               | 106-46-7   | SW8260C | EPA MCL         | 75  | 1.00          |
| 2-Butanone (Methyl Ethyl Ketone)                  | 78-93-3    | SW8260C | EPA RSL         | 560                                       | 10.0          |
| 2-Hexanone  | 591-78-6   | SW8260C | EPA RSL         | 3.8 <sup>b</sup>                          | 10.0          |
| 4-Methyl-2-pentanone                              | 108-10-1   | SW8260C | EPA RSL         | 630                                       | 10.0          |
| Acetone   | 67-64-1    | SW8260C | EPA RSL         | 1,400                                     | 10.0          |
| Benzene   | 71-43-2    | SW8260C | EPA MCL         | 5   | 1.00          |
| Bromochloromethane                                | 74-97-5    | SW8260C | EPA RSL         | 8.3                                       | 1.00          |
| Bromodichloromethane                              | 75-27-4    | SW8260C | EPA MCL         | 80  | 1.00          |
| Bromoform   | 75-25-2    | SW8260C | EPA MCL         | 80  | 1.00          |
| Bromomethane                                      | 74-83-9    | SW8260C | EPA RSL         | 0.75 <sup>b</sup>                         | 1.00          |
| Carbon Disulfide                                  | 75-15-0    | SW8260C | EPA RSL         | 81  | 1.00          |
| Carbon Tetrachloride                              | 56-23-5    | SW8260C | EPA MCL         | 5   | 1.00          |
| Chlorobenzene                                     | 108-90-7   | SW8260C | EPA MCL         | 100                                       | 1.00          |
| Chloroethane                                      | 75-00-3    | SW8260C | EPA RSL         | 2,100                                     | 2.00          |
| Chloroform  | 67-66-3    | SW8260C | EPA MCL         | 80  | 1.00          |
| Chloromethane                                     | 74-87-3    | SW8260C | EPA RSL         | 19  | 1.00          |
| cis-1,2-Dichloroethene                            | 156-59-2   | SW8260C | EPA MCL         | 70  | 1.00          |
| Dibromochloromethane                              | 124-48-1   | SW8260C | EPA MCL         | 80  | 1.00          |
| Dichlorodifluoromethane (Freon 12)                | 75-71-8    | SW8260C | EPA RSL         | 20  | 1.00          |
| Ethylbenzene                                      | 100-41-4   | SW8260C | EPA MCL         | 700                                       | 1.00          |
| Isopropylbenzene (Cumene)                         | 98-82-8    | SW8260C | EPA RSL         | 45  | 1.00          |

**Table 2-9. Project Laboratory (EMAX Laboratories, Inc.)– Target Analytes and Reporting Limits – Volatile Organic Compounds in Water (Groundwater/Surface Water)**

*Quality Assurance Project Plan, OU-2 Remedial Investigation 700 South 1600 East PCE Plume, Salt Lake City, Utah*

| Analyte                                       | CAS Number            | Method  | Screening Level | Screening Level Value (µg/L) <sup>a</sup> | Lab RL (µg/L) |
|---|-----------------------|---------|-----------------|---|---------------|
| Methyl acetate                                | 79-20-9               | SW8260C | EPA RSL         | 2,000                                     | 2.00          |
| Methyl Tert-Butyl Ether                       | 1634-04-4             | SW8260C | EPA RSL         | 14  | 1.00          |
| Methylene chloride                            | 75-09-2               | SW8260C | EPA MCL         | 5   | 2.00          |
| m,p-Xylene                                    | 108-38-3 and 106-42-3 | SW8260C | EPA RSL         | 19  | 2.00          |
| o-Xylene                                      | 95-47-6               | SW8260C | EPA RSL         | 19  | 1.00          |
| Styrene                                       | 100-42-5              | SW8260C | EPA MCL         | 100                                       | 1.00          |
| Tetrachloroethene (PCE)                       | 127-18-4              | SW8260C | EPA MCL         | 5   | 1.00          |
| Toluene                                       | 108-88-3              | SW8260C | EPA MCL         | 1,000                                     | 1.00          |
| Total 1,3-dichloro propene (cis- and trans- ) | 542-75-6              | SW8260C | EPA RSL         | 0.47 <sup>b</sup>                         | 1.00          |
| trans-1,2-Dichloroethene                      | 156-60-5              | SW8260C | EPA MCL         | 100                                       | 1.00          |
| Trichloroethene                               | 79-01-6               | SW8260C | EPA MCL         | 5   | 1.00          |
| Trichlorofluoromethane (Freon 11)             | 75-69-4               | SW8260C | EPA RSL         | 520                                       | 1.00          |
| Vinyl Acetate                                 | 108-05-4              | SW8260C | EPA RSL         | 41  | 2.00          |
| Vinyl Chloride                                | 75-01-4               | SW8260C | EPA MCL         | 2   | 1.00          |
| <b>Field Screening Parameters</b>             |                       |         |                 |   |               |
| cis-1,2-Dichloroethene                        | 156-59-2              | HAPSITE | EPA MCL         | 70  | 5.0           |
| Tetrachloroethene                             | 127-18-4              | HAPSITE | EPA MCL         | 5   | 5.0           |
| Trichloroethene                               | 79-01-6               | HAPSITE | EPA MCL         | 5   | 5.0           |

<sup>a</sup> If an MCL is set for the analyte the screening level is the MCL. Otherwise the screening level is the RSL for tap water. RSLs corresponding to an excessive lifetime cancer risk of  $1 \times 10^{-6}$  and a hazard quotient of 0.1 were used (November 2017).

<sup>b</sup> Due to the low screening level for this analyte, the RL is greater than the screening level. However, this analyte is not a known constituent of potential concern for the site.

**Notes:**

µg/L = microgram(s) per liter

CAS = Chemical Abstracts Service

EPA = U.S. Environmental Protection Agency

MCL = maximum contaminant level

RL = reporting limit

RSL = regional screening level

**Table 2-10. Project Laboratory (EMAX Laboratories, Inc.) – Target Analytes and Reporting Limits – Semivolatile Organic Compounds in Water (Groundwater/Surface Water)**

*Quality Assurance Project Plan, OU-2 Remedial Investigation 700 South 1600 East PCE Plume, Salt Lake City, Utah*

| <b>Analyte</b> | <b>CAS Number</b> | <b>Method</b> | <b>Screening Level</b> | <b>Screening Level Value (µg/L)<sup>a</sup></b> | <b>Lab RL (µg/L)</b> |
|----------------|-------------------|---------------|------------------------|---|----------------------|
| 1,4-Dioxane    | 123-91-1          | SW8270SIM     | EPA RSL                | 0.46  | 0.3                  |

<sup>a</sup> If an MCL is set for the analyte the screening level is the MCL. Otherwise, the screening level is the RSL for tap water. RSLs corresponding to an excessive lifetime cancer risk of  $1 \times 10^{-6}$  and a hazard quotient of 0.1 were used (November 2017).

Notes:

µg/L = microgram(s) per liter

CAS = Chemical Abstracts Service

EPA = U.S. Environmental Protection Agency

MCL = maximum contaminant level

RL = reporting limit

RSL = regional screening level

1



**Table 2-11. Project Laboratory (EMAX Laboratories, Inc.) – Target Analytes and Reporting Limits – Metals in Water (Groundwater/Surface Water)**

*Quality Assurance Project Plan, OU-2 Remedial Investigation 700 South 1600 East PCE Plume, Salt Lake City, Utah*

| Analyte   | CAS Number | Method   | Screening Level | Screening Level Value (µg/L) <sup>a</sup> | Lab RL (µg/L)     |
|-----------|------------|----------|-----------------|---|-------------------|
| Aluminum  | 7429-90-5  | SW60620A | EPA RSL         | 2000                                      | 100 <del>50</del> |
| Antimony  | 7440-36-0  | SW60620A | EPA MCL         | 6   | 1                 |
| Arsenic   | 7440-38-2  | SW60620A | EPA MCL         | 10  | 1                 |
| Barium    | 7440-39-3  | SW60620A | EPA MCL         | 2000                                      | 1                 |
| Beryllium | 7440-41-7  | SW60620A | EPA MCL         | 4   | 1                 |
| Cadmium   | 7440-43-9  | SW60620A | EPA MCL         | 5   | 1                 |
| Calcium   | 7440-70-2  | SW60620A | --              | NA  | 100               |
| Chromium  | 7440-47-3  | SW60620A | EPA MCL         | 100                                       | 1                 |
| Cobalt    | 7440-48-4  | SW60620A | EPA RSL         | 0.6 <sup>b</sup>                          | 1                 |
| Copper    | 7440-50-8  | SW60620A | EPA MCL         | 1,300                                     | 1                 |
| Iron      | 7439-89-6  | SW60620A | EPA RSL         | 1,400                                     | 100               |
| Lead      | 7439-92-1  | SW60620A | EPA MCL         | 15  | 1                 |
| Magnesium | 7439-95-4  | SW60620A | --              | N/A                                       | 100               |
| Manganese | 7439-96-5  | SW60620A | EPA RSL         | 43  | 1                 |
| Mercury   | 7487-94-7  | SW7470A  | EPA MCL         | 2   | 0.5               |
| Nickel    | 7440-02-0  | SW60620A | EPA RSL         | 39  | 1                 |
| Potassium | 7440-09-7  | SW60620A | --              | NA  | 100               |
| Selenium  | 7782-49-2  | SW60620A | EPA MCL         | 50  | 1                 |
| Silver    | 7440-22-4  | SW60620A | EPA RSL         | 9.4                                       | 1                 |
| Sodium    | 7440-23-5  | SW60620A | --              | NA  | 100               |
| Thallium  | 7440-28-0  | SW60620A | EPA MCL         | 2   | 1                 |
| Vanadium  | 7440-62-2  | SW60620A | EPA RSL         | 8.6                                       | 1                 |
| Zinc      | 7440-66-6  | SW60620A | EPA RSL         | 600                                       | 20                |

<sup>a</sup> If an MCL is set for the analyte the screening level is the MCL. Otherwise, the screening level is the RSL for tap water. RSLs corresponding to an excessive lifetime cancer risk of  $1 \times 10^{-6}$  and a hazard quotient of 0.1 were used (November 2017).

<sup>b</sup> Due to the low screening level for this analyte, the RL is greater than the screening level. However, this analyte is not a known constituent of potential concern for the site.

Notes:

µg/L = microgram(s) per liter

CAS = Chemical Abstracts Service

EPA = U.S. Environmental Protection Agency

MCL = maximum contaminant level

NA = not applicable

RL = reporting limit

RSL = regional screening level

**Table 2-13. Project Laboratory (EMAX Laboratory, Inc.) – Target Analytes and Reporting Limits – General Water Quality/Natural Attenuation Parameters in Water (Groundwater/Surface Water)**

*Quality Assurance Project Plan, OU-2 Remedial Investigation 700 South 1600 East PCE Plume, Salt Lake City, Utah*

| Analyte                             | CAS Number                 | Method                                | Screening Level | Screening Level           |               |
|-------------------------------------|----------------------------|---------------------------------------|-----------------|---------------------------|---------------|
|                                     |                            |                                       |                 | Value (mg/L) <sup>a</sup> | Lab RL (mg/L) |
| TOC                                 | TOC                        | SW9060                                | --              | NA                        | 1             |
| TDS                                 | TDS                        | SM2540C                               | --              | NA                        | 10            |
| Ethane (Dissolved Gas)              | 74-84-0                    | RSK-175                               | --              | NA                        | 0.002         |
| Ethene (Dissolved Gas)              | 74-85-1                    | RSK-175                               | --              | NA                        | 0.002         |
| Methane (Dissolved Gas)             | 74-82-8                    | RSK-175                               | --              | NA                        | 0.002         |
| Chloride                            | 16887-00-6                 |                                       | --              | NA                        | 0.2           |
| Nitrate/Nitrite                     | 14797-55-8/<br>14797-65-0  | E300.0                                | EPA MCL         | 10/1.0                    | 0.1           |
| Sulfate                             | 14808-79-8                 |                                       | --              | NA                        | 0.5           |
| Nitrate/Nitrite-N                   | 14797-55-8 /<br>14797-65-0 | SM4500-NO3E                           | EPA MCL         | 10/1.0                    | 0.1           |
| Sulfide                             | 18496-25-8                 | SM4500S2-CF                           | --              | NA                        | 1             |
| Alkalinity                          | ALK                        | SM2320B                               | --              | NA                        | 5             |
| Stable Oxygen and Hydrogen Isotopes | NA                         | Picarro Cavity Ring-Down Spectroscopy |                 | NA                        | NA            |

<sup>a</sup> If an MCL is set for the analyte the screening level is the MCL. Otherwise the screening level is the RSL for tap water or, if no RSL is set, the soil screening level for groundwater protection using a dilution attenuation factor of 20, and soil saturation level. RSLs corresponding to an excessive lifetime cancer risk of  $1 \times 10^{-6}$  and a hazard quotient of 0.1 were used.

Notes:

CAS = Chemical Abstracts Service

EPA = U.S. Environmental Protection Agency

MCL = maximum contaminant level

mg/L = milligram(s) per liter

NA = not applicable

qPCR = quantitative polymerase chain reaction

RL = reporting limit

RSL = regional screening level

TDS = total dissolved solids

TOC = total organic carbon

## 2.4.2 Data Quality Indicators and Quality Control Sample/Measurement Performance

The QA objective of this plan is to identify procedures and criteria that will provide data of known and appropriate quality for the needs identified in Section 2.4.1. Data quality is assessed by representativeness, comparability, accuracy, precision, and completeness. These parameters, the applicable procedures, and level of effort are described in the following paragraphs.

The applicable QC procedures, quantitative target limits, and level of effort for assessing data quality are dictated by the intended use of the data and nature of the analytical methods. Analytical precision, accuracy, and completeness align with the needs identified in Section 2.4.1. Analytical methods and quality control procedures are further detailed in Section 3.

To assess the quality of the data generated during this site investigation, the data quality indicators of precision, accuracy, representativeness, comparability, completeness, and sensitivity will be evaluated against project-specific measurement performance criteria (MPC).

**Precision** is the measure of variability among individual sample measurements under prescribed conditions. The relative percent difference (RPD) between primary and field duplicate (FD) samples, laboratory sample duplicate pairs, and matrix spike/matrix spike duplicate (MS/MSD) sample results demonstrate the precision of the sample matrix. The level of effort for precision measurements will be a minimum of 1 in 10 samples for FDs and a minimum of 1 in 20 samples for MS/MSDs. Precision will be calculated from duplicate measurements as follows:

$$RPD = \frac{(C_1 - C_2)}{(C_1 + C_2) / 2} \times 100\% \quad (1)$$

where:

RPD = relative percent difference

C1 = larger of the two observed values

C2 = smaller of the two observed values

If calculated from three or more replicates, use relative standard deviation (RSD) rather than RPD:

$$RSD = (s / \bar{y}) \times 100\% \quad (2)$$

where:

RSD = relative standard deviation

S = standard deviation

$\bar{y}$  = mean of replicate analyses

Standard deviation,  $s$ , is defined as follows:

$$S = \sqrt{\sum_{i=1}^n \frac{(y_i - \bar{y})^2}{n - 1}} \quad (3)$$

where:

S = standard deviation

$y_i$  = measured value of the  $i$ th replicate

1  $\bar{y}$  = mean of replicate analyses  
2 N = number of replicates

3 **Accuracy** is a measure of the closeness of a reported concentration to the true value. Accuracy is  
4 expressed as a bias (high or low) and is determined by calculating percent recovery (%R) from  
5 MS/MSDs and laboratory control samples (LCS). MS/MSD recoveries (from field samples) indicate  
6 accuracy relevant to a unique sample matrix. LCS recoveries (including surrogate spikes) indicate  
7 accuracy relevant to an analytical batch lot and are strictly a measure of analytical accuracy  
8 conditions independent of samples and matrices. The %R of an analyte, and the resulting degree of  
9 accuracy expected for the analysis of QC spike samples, are dependent upon the sample matrix,  
10 method of analysis, and the compound or element being measured. For measurements where MSs  
11 are used:

12 
$$\%R = 100\% \times \left[ \frac{S - U}{C_{sa}} \right] \quad (4)$$

13 where:  
14 %R = percent recovery  
15 S = measured concentration in spiked aliquot  
16 U = measured concentration in unspiked aliquot  
17 C<sub>sa</sub> = actual concentration of spike added

18 For situations where a standard reference material (SRM) is used instead of or in addition to MSs:

19 
$$\%R = 100\% \times \left[ \frac{C_m}{C_{sm}} \right] \quad (5)$$

20 where:  
21 %R = percent recovery  
22 C<sub>m</sub> = measured concentration of SRM  
23 C<sub>sm</sub> = actual concentration of SRM

24 **Representativeness** is a measure of how closely the results reflect the actual concentration or  
25 distribution of the chemical compounds in the matrix samples. Sampling plan design, sampling  
26 techniques, and sample-handling protocols (for example, for storage, preservation, and  
27 transportation) were developed and are discussed in Section 3. The associated documentation will  
28 establish that protocols were followed and sample identification and integrity were maintained.

29 **Comparability** expresses the confidence with which one data set can be compared to another.  
30 Data comparability will be maintained using defined procedures and the use of consistent methods  
31 and consistent units of measurement. Actual detection limits will depend on the sample matrix and  
32 will be reported as defined for the specific samples.

33 **Completeness** is a measure of the amount of valid data obtained from the analytical measurement  
34 system and the complete implementation of defined field procedures. The target completeness  
35 objective will be 90 percent; the actual completeness may vary depending on the intrinsic nature of  
36 the samples. Completeness is defined as follows for all measurements:

1 
$$\%C = 100\% \times \left[ \frac{V}{T} \right] \tag{6}$$

2 where:

3 %C = percent completeness

4 V = number of measurements judged valid

5 T = total number of measurements

6 Assessment of data for representativeness and comparability will comply with the following  
7 qualitative definitions:

8 Sensitivity of the data is evaluated by comparing the laboratory MDL study results to values  
9 reported for the project data. The lowest calibration standard is used to determine the reported  
10 laboratory limits. The reported laboratory limits are compared to the project action limits and  
11 screening criteria to assess whether sensitivity was adequate for project needs.

## 12 2.5 Special Training/Certification (A8)

13 All project staff working onsite must be health and safety trained and must follow requirements  
14 specified in the health and safety plan including the 40-hour Hazardous Waste Operations Training  
15 and annual 8-hour refresher training. In addition, the FTL will have completed the 8-hour  
16 Hazardous Waste Operations Supervisor Training and the HAPSITE operator will have completed  
17 the KD Analytical HAPSITE Basic and Advanced Operator Training. The health and safety plan  
18 describes the specialized training, including tracking and documentation, required for personnel on  
19 the project. The PM will confirm that all field staff have the appropriate training and certifications  
20 (if required) for their assigned tasks. Training records are maintained in CDM Smith’s health and  
21 safety database. Certifications are verified as part of a readiness review before initiation of work.  
22 Table 2-14 provides a summary of the training requirements for the project. If a designee is  
23 appointed for any project function, that designee will meet the training and certification  
24 requirements. The project staff is summarized in Table 2-1.

## 25 2.6 Documents and Records (A9)

26 Field documentation and records are described in Section 5.11 of the FSP (Appendix A-1 of the  
27 RIWP) and standard operating procedures (SOPs) 4-1, *Field Logbook Content and Control*, 4-2,  
28 *Photographic Documentation of Field Activities*, and 1-2, *Sample Custody* (Appendix A, which  
29 supersedes the SOPs provided in the RIWP). Field documentation records and electronic files that  
30 will be generated during the RI include the following:

- 31 ■ Field logbooks
- 32 ■ Field forms
- 33 ■ Photographs (electronic files)
- 34 ■ Chain-of-custody forms
- 35 ■ GPS data (electronic files)

36 Field logbooks, field forms, and chain-of-custody forms will be handwritten in the field, reviewed by  
37 the PM or designated project reviewer within 1 week of the field task completion, and scanned.

1 Scanned field forms will be submitted to VHA, uploaded to the project file on Microsoft SharePoint,  
2 and included in technical memorandums/final reports that summarize field activities. Field  
3 logbooks, field forms, and photographs are discussed in SOP 4-1, *Field Documentation* and SOP 4-2,  
4 *Photographic Documentation of Field Activities*; chain-of-custody documentation is discussed in SOP  
5 1-2, *Sample Custody* (Appendix A).

**Table 2-14. Specialized Training Requirements**

*Quality Assurance Project Plan, OU-2 Remedial Investigation 700 South 1600 East PCE Plume, Salt Lake City, Utah*

| <b>Project Function</b>                                  | <b>Specialized Training – Title or Description of Course</b>   | <b>Training Date</b>  | <b>Personnel/Groups Receiving Training</b> | <b>Personnel Titles/ Organizational Affiliation</b>        | <b>Location of Training Records/Certificates</b>                                   |
|--|--|---|--|--|--|
| Field Team Leader  | <ul style="list-style-type: none"> <li>• 40-Hour Hazardous Waste Operations</li> <li>• 8-Hour Hazardous Waste Site Supervisor Training</li> <li>• 8-Hour Hazardous Waste Operations Refresher</li> </ul> | <ul style="list-style-type: none"> <li>• 2005</li> <li>• 2008</li> <li>• Current</li> </ul> | Neil Smith or designee                     | Field Team Leader  | Certificates available upon request and documentation files are maintained onsite. |
| Field Staff  | <ul style="list-style-type: none"> <li>• 40-Hour Hazardous Waste Site Worker</li> <li>• 8-Hour Refresher</li> </ul>  | <ul style="list-style-type: none"> <li>• Current</li> </ul>                                 | All field staff                            | Field technicians, geologist, equipment operators, various | Certificates available upon request and documentation files are maintained onsite. |
| HAPSITE Gas Chromatograph/<br>Mass Spectrometer Operator | <ul style="list-style-type: none"> <li>• KD Analytical Training Certificate</li> <li>• 40-Hour Hazardous Waste Site Worker</li> <li>• 8-Hour Refresher</li> </ul>  | <ul style="list-style-type: none"> <li>• 2017</li> <li>• 1991</li> <li>• Current</li> </ul> | Todd Burgess or designee                   | HAPSITE Operator   | Certificates available upon request and documentation files are maintained onsite. |

1 Laboratory documentation will follow method requirements and QA protocols listed in Section 3.  
2 Laboratory documentation will be retained for a minimum of 3 years after contract closeout.  
3 A complete list of the documents, records, and electronic files provided in the laboratory data  
4 package will include the following:

- 5     ▪ Case narrative
- 6     ▪ Summary results
- 7     ▪ Chain of custody
- 8     ▪ QC results
- 9     ▪ Method summary
- 10    ▪ Chromatograms

11 A detailed listing of the various required elements that will be included in the laboratory data  
12 package is provided in Section 2.6.1.

13 Data management procedures are described in Section 5.4.1 of the RIWP (CH2M, 2018).

#### 14 **2.6.1 Analytical Data Package**

15 An EPA Level IV Contract Laboratory Program equivalent data package will be provided by the  
16 project laboratory with exception of the laboratories providing stable isotope and geotechnical  
17 testing, with the following information (when applicable) for each data deliverable:

- 18     ▪ Cover letter complete with the following information:
  - 19         • Title of report and laboratory unique report identification
  - 20         • Project name and site location
  - 21         • Name and location of laboratory and second-site or subcontracted laboratory
  - 22         • Client name and address
  - 23         • Statement of authenticity and official signature and title of person authorizing report  
24             release
- 25     ▪ Table of contents (paginated pages)
- 26     ▪ Summary of samples received that correlates field sample identification (ID) with the  
27         laboratory ID
- 28     ▪ Laboratory qualifier flags and definitions
- 29     ▪ Field ID number
- 30     ▪ Date received
- 31     ▪ Date prepared



- 1     ▪ Date analyzed (and time of analysis if the holding time is less than or equal to 48 hours)
- 2     ▪ Preparation and analytical methods
- 3     ▪ Result for each analyte (dry weight basis for soils)
- 4     ▪ Percent solids results for soil samples
- 5     ▪ Dilution factor (provide both diluted and undiluted results when available)
- 6     ▪ Sample-specific RL adjusted for sample size, dilution/concentration
- 7     ▪ Sample-specific MDL adjusted for sample size and dilution/concentration (project objectives
- 8         require reporting to the MDL)
- 9     ▪ Units
- 10    ▪ Case narrative that addresses the following information at a minimum:
  - 11       • Sample receipt discrepancies, such as bubbles in VOC samples and temperature
  - 12        exceedances
  - 13       • Descriptions of all non-conformances in the sample receipt, handling, preparation,
  - 14        analytical and reporting processes, and the corrective action taken in each occurrence
  - 15       • Identification and justification for sample dilution
- 16    ▪ Surrogate percent recoveries
- 17    ▪ MS/MSD and LCS spike concentrations, native sample results, spiked sample results, percent
- 18       recoveries, and RPDs between the MS and MSD results. Associated QC limits must also be
- 19       provided
- 20    ▪ Method blank results
- 21    ▪ Analytical batch reference number that cross references samples to QC sample analyses
- 22    ▪ Chain-of-custody and sample receipt checklist
- 23    ▪ Analytical sequence or laboratory run log that contains sufficient information to correlate
- 24       samples reported in the summary results to the associated method QC information, such as
- 25       initial and continuing calibration analyses
- 26    ▪ The measured final residual vacuum of each sample canister measured with a digital meter
- 27       immediately prior to analysis
- 28    ▪ Confirmation results
- 29    ▪ Calibration blank results for inorganic analyses (required in hard copy format only)
- 30    ▪ Interference check sample true and measured concentrations and percent recoveries
- 31       (required in hard copy format only)
- 32    ▪ Method of standard addition results (if applicable; required in hard copy format only)

- 1     ■ Post-digestion spike recoveries (if applicable; required in hard copy format only)
- 2     ■ Internal standard recovery and retention time information, as applicable
- 3     ■ Initial calibration summary, including standard concentrations, response factors, average  
4       response factors, RSDs or correlation coefficients, and calibration plots or equations, if  
5       applicable (required in hard copy format only)
- 6     ■ Continuing calibration verification summary, including expected and recovered  
7       concentrations and percent differences (required in hard copy format only)
- 8     ■ Instrument tuning and mass calibration information as applicable
- 9     ■ Any other method-specific QC sample results plus full supporting raw instrument data,  
10       records of standard preparation, manual integrations, example calculations, spectra,  
11       chromatograms, sample preparation logs, a full EPA Level IV data deliverable equivalent

## 12   **2.6.2 Electronic Data Deliverable Format**

13   Electronic data deliverables (EDD) are required for all laboratory analytical data. An automated  
14   laboratory information management system must be used to produce the EDD from the same  
15   source as the data; manual creation of the deliverable (data entry by hand) is unacceptable. The  
16   EDD will correspond exactly to the hard copy data report. The subcontractor laboratories will  
17   provide the data in accordance with the EDD specifications for EQUS at  
18   earthsoft.com/support/edd-formats/EQEDD. All project analytical data will be uploaded to the  
19   EQUS project database for reporting and archiving.

20   Per Federal Acquisition Regulation (FAR) 52.215-2 (Audit and Records), electronic and hard copy  
21   laboratory data must be retained by CDM Smith for a minimum of 3 years after contract closeout.  
22   The laboratory will use a storage device that is capable of recording data for long-term, offline  
23   storage. The project consultant team will also retain backup hard copies of field and laboratory  
24   data in project files and electronic copies on an offsite file sharing network.

### 25   Project Information/Records Storage and Retention

26   CDM Smith will retain the entire project file as hard copy and/or electronic data on CDM Smith  
27   project servers until the completion of all project activities or sent to VHA when requested.  
28   Thereafter, all data will be transferred to VHA, and CDM Smith will archive and maintain the data in  
29   a secure and protected facility for a minimum of 3 years after contract closeout, per FAR 52.215-2  
30   (Audit and Records). Analytical results and sample location data collected during the RI will be  
31   entered into a geographic information system (GIS) database for mapping and publication, and the  
32   GIS metadata and files will be transferred to VHA and archived by CDM Smith in electronic format  
33   for transmittal to EPA and UDEQ, if requested.

34   Backup copies of electronic data, including PDF files of documents will be stored offsite on a  
35   SharePoint server maintained by CDM Smith during the term of the contract, and at the end of the  
36   contract, transferred to an offsite data archive site.

37   The official administrative record for the site is located at Salt Lake City Public Library – Foothill-  
38   Anderson Branch, in Salt Lake City, Utah. A copy of the administrative record will be maintained at  
39   the VHA Salt Lake City Health Care System at 500 Foothill Drive in Salt Lake City, Utah 84148. Hard

1 copies of project reports, including the RIWP, FSP, and QAPP will be available in hard and electronic  
2 copies for the duration of the CERCLA project. EPA Region 8 in Denver, Colorado, and UDEQ in Salt  
3 Lake City, Utah, will receive all copies of documents, lab data, and other published project  
4 information for their records.



# 1 Section 3

## 2 Data Generation and Acquisition (EPA Group B)

3 This section describes the sampling design; sampling methods; sample handling and custody;  
4 analytical methods; QC; instrument/equipment testing, inspection, and maintenance; instrument/  
5 equipment calibration and frequency and inspection/acceptance of supplies and consumables;  
6 nondirect measurements; and data management.

### 7 3.1 Sampling Design (Experimental Design) (B1)

8 The rationale for and the sampling design is described in step seven of the DQO process for each  
9 problem statement associated with the RI field work is summarized in Table 2-2. Details are  
10 provided in Section 5 of the RIWP and Section 3 of the FSP (Appendix A-1 to the RIWP [CH2M,  
11 2018]). Analytical methods include the following:

- 12 ■ Contaminant analyses (VOCs, SVOCs, and total metals)
- 13 ■ General water quality and natural attenuation parameters (stable isotopes of hydrogen and  
14 oxygen, total organic carbon, total dissolved solids, chloride, sulfate, nitrate/nitrite, and  
15 alkalinity)
- 16 ■ Geotechnical parameters for soil
- 17 ■ Water quality field parameters [pH, oxidation-reduction potential, dissolved oxygen (DO),  
18 specific conductance, temperature, and turbidity]

### 19 3.2 Sampling Methods (B2)

20 Sampling methods specify how samples will be collected in terms of sampling equipment, sample  
21 volumes, containers, subsamples, preservation, and decontamination requirements. The sampling  
22 may include:

- 23 ■ Soil samples collected during well installation or during source area investigation
- 24 ■ Soil gas samples collected during source area investigation
- 25 ■ Groundwater samples collected by:
  - 26 ● Passive diffusion sampling
  - 27 ● Low-flow groundwater sampling
  - 28 ● Low-yield well sampling
  - 29 ● Zone Isolation Sampling Technology wells

30 Methods and protocols are described in further detail in Section 5 of the RIWP and Section 5 of the  
31 FSP (Appendix A-1 of the RIWP [CH2M, 2018]). Sampling SOPs are itemized and provided in  
32 Appendix A.

### 3.3 Sample Handling and Custody (B3)

A sample is physical evidence collected from a hazardous waste site, from the immediate environment, or from another source. Because of the potential evidentiary nature of samples, VHA must have sample possession tracked from the time of sample collection until samples are introduced as evidence.

In addition to field notebooks, VHA requires CDM Smith to use a number of documents for tracking sample custody. Field documents include sample custody seals and chain-of-custody records. CDM Smith will use chain-of-custody procedures to maintain and document sample collection and possession, as described in Section 3.3.3.

#### 3.3.1 Sample Labeling

All sample labels will include at a minimum the following information:

- Sample name/number
- Time and date of sample collection
- Site name and location
- Project number
- Sample type and matrix
- Container
- Preservative
- Analysis method

The process for labelling samples, as well as the sample nomenclature, is provided in further detail in Section 5.11.2 of the FSP (Appendix A-1 of the RIWP [CH2M, 2018]).

#### 3.3.2 Packaging and Shipping

Samples that require cooling to 4 degrees Celsius (°C) will immediately be placed on ice for temporary storage before and during shipment to the laboratory. All samples will be packaged and labeled for shipment in compliance with current U.S. Department of Transportation regulations. Samples will be shipped, or hand delivered, to the laboratory as soon as practicable.

Only metal or plastic ice chests will be used for shipping samples that require cooling. For shipment to the project laboratory, samples will be properly padded to prevent breakage. Ice used in the coolers will be placed in double, one-gallon zip-lock bags with a minimum amount of air. The chain-of-custody record will be placed inside a zip-lock plastic bag and taped to the inside of the cooler top. The cooler will be closed and taped shut with packing tape or duct tape, and a signed and dated custody seal will be properly placed across two sides of the cooler lid. The shipping air bill, if needed, will be securely attached to the exterior of the cooler.

Samples not requiring cooling, such as Summa canister air samples, will be packaged in the cardboard containers they were received in from the laboratory and shipped or delivered via

1 courier to the laboratory directly following collection. The chain-of-custody record will be placed  
2 in one of the boxes.

3 Commercial carriers are not required to sign the chain-of-custody record if it is sealed inside the  
4 shipping cooler and the custody seals remain intact. The laboratories are responsible for storing  
5 the samples in a secure location and following chain-of-custody procedures.

6 Soil and water samples will be collected in certified clean containers provided by the project  
7 laboratory. Soil gas samples for EPA Method TO-15 analysis will be collected in clean, certified  
8 Summa canisters (individually-certified) with clean flow controllers. The requirements for sample  
9 volumes, sampling containers, preservation, and holding times are summarized in Table 3-1.

**Table 3-1. Recommended Sample Container, Preservation, and Holding Times**

*Quality Assurance Project Plan, OU-2 Remedial Investigation 700 South 1600 East PCE Plume, Salt Lake City, Utah*

| Parameter                          | Method      | Matrix   | Holding Time<br>(From Date Sampled)                                      | Container   | Preservative                                   |
|------------------------------------|-------------|----------|--|---|--|
| <b>Organics</b>                    |             |          |  |   |  |
| Dissolved Gases                    | RSK-175     | Water    | 14 days  | 3 × 40 mL glass VOA vial <sup>a,b</sup>                                       | ≤6°C, HCl to pH < 2                            |
| VOCs                               | SW8260C     | Soil     | 48 hours to preservation, Encore samplers 14 days from sample collection | 4 × 5 grams Encore <sup>b</sup><br>1 × 4-ounce glass jar for moisture content | ≤6°C   |
| VOCs                               | SW8260C     | Water    | 14 days  | 3 × 40 mL glass VOA vial <sup>a,b</sup>                                       | ≤6°C, HCl to pH < 2                            |
| SVOCs                              | SW8270D     | Soil     | 14 days to extraction, 40 days to analysis                               | 50 grams minimum in one 8-ounce wide mouth glass jar <sup>b</sup>             | ≤6°C   |
| SVOCs                              | SW8270D     | Water    | 7 days to extraction, 40 days to analysis                                | 1 × 1 L wide mouth glass bottle   | ≤6°C   |
| VOCs                               | TO-15       | Soil Gas | 30 days  | 1 L or 6 L Summa Canister   | NA   |
| <b>Inorganic</b>                   |             |          |  |   |  |
| Metals (except Mercury)            | SW6020A     | Water    | 180 days   | 1 L polyethylene bottle   | HNO <sub>3</sub> to pH < 2                     |
| Metals (except Mercury)            | SW6020A     | Soil     | 180 days   | Fill one 8-ounce wide mouth glass jar   | NA   |
| Mercury                            | SW7470A     | Water    | 28 days  | 1 L polyethylene bottle   | HNO <sub>3</sub> to pH < 2                     |
| Mercury                            | SW7471A     | Soil     | 28 days  | Fill one 8-ounce wide mouth glass jar   | NA   |
| <b>General Chemistry</b>           |             |          |  |   |  |
| Chloride, Nitrate/Nitrite, Sulfate | E300.0      | Water    | 28 days, Nitrate/Nitrite 48 hours  | 1L polyethylene bottle  | ≤6°C   |
| Nitrate/Nitrite-N                  | SM4500-NO3E | Water    | 28 days  | Fill one 125 mL polyethylene bottle   | <6°C, H <sub>2</sub> SO <sub>4</sub> to pH < 2 |
| Sulfide                            | SM4500S2-CF | Water    | 7 days   | 250 mL polyethylene bottle  | ≤6°C, NaOH to pH>10; ZnAc                      |
| TDS                                | SM2540C     | Water    | 7 days   | 1 L polyethylene bottle   | ≤6°C   |
| TOC                                | SW9060      | Water    | 28 days  | 250 mL wide mouth glass bottle  | ≤6°C, H <sub>2</sub> SO <sub>4</sub> to pH < 2 |
| Alkalinity                         | SM2320B     | Water    | 14 days  | 1 L polyethylene bottle   | ≤6°C   |



**Table 3-1. Recommended Sample Container, Preservation, and Holding Times**

*Quality Assurance Project Plan, OU-2 Remedial Investigation 700 South 1600 East PCE Plume, Salt Lake City, Utah*

| Parameter                           | Method                               | Matrix | Holding Time<br>(From Date Sampled) | Container                             | Preservative |
|-------------------------------------|--------------------------------------|--------|-------------------------------------|---------------------------------------|--------------|
| Stable Oxygen and Hydrogen Isotopes | Isotope Ratio Mass Spectroscopy      | Water  | 180 days                            | 2 × 20 mL glass vial                  | ≤6°C         |
| <b>Geotechnical</b>                 |                                      |        |                                     |                                       |              |
| FOC                                 | ASTM D2974                           | Soil   | 28 days                             | Fill one 4-ounce wide mouth glass jar | ≤6°C         |
| Magnetic Susceptibility             | Microbial Insights Laboratory Method | Soil   | NA                                  | Fill one 250-mL polyethylene jar      | None         |
| Sieve Analysis                      | ASTM D6913                           | Soil   | NA                                  | 5-gallon bucket                       | None         |
| Dry Bulk Soil Density               | ASTM D2937                           | Soil   | NA                                  | Shelby Tube                           | None         |
| Hydrometer                          | ASTM D422a                           | Soil   | NA                                  | 1 gallon bag                          | None         |
| USCS Soil Classification            | ASTM D2487                           | Soil   | NA                                  | 1 gallon bag                          | None         |
| Atterberg Limits                    | ASTM D4318                           | Soil   | NA                                  | From USCS bag                         | None         |
| Gradation                           | ASTM D1140                           | Soil   | NA                                  | 5-gallon bucket                       | None         |
| Vertical Permeability               | ASTM D2434                           | Soil   | NA                                  | Shelby Tube                           | None         |
| Moisture Content                    | ASTM D2216                           | Soil   | NA                                  | 1-quart bag                           | None         |

<sup>a</sup> Additional sample volume required for selective ion matrix analysis.

<sup>b</sup> Additional sample volume required for matrix spike/matrix spike duplicate analysis

Notes:

°C = degrees Celsius

FOC = fraction of organic carbon

H<sub>2</sub>SO<sub>4</sub> = sulfuric acid

HCl = hydrochloric acid

HNO<sub>3</sub> = nitric acid

H<sub>2</sub>SO<sub>4</sub> = sulfuric acid

L = liter

mL= milliliter(s)

NA = not applicable

NaOH = sodium hydroxide

SVOC = semivolatile organic compound

TDS = total dissolved solid

TOC = total organic carbon

VOA = volatile organic analytic

ZnAc = zinc acetate

### 1 **3.3.3 Chain of Custody**

2 A chain-of-custody record establishes the documentation necessary to trace sample possession  
 3 from time of collection through sample analysis and final disposition, and serves to document the  
 4 specific analyses requested from the laboratory. A sample is in the custody of a person if any of the  
 5 following criteria are met:

- 6     ■ The sample is in a person's physical possession.
- 7     ■ The sample is in a person's view after being in his or her physical possession.

- 1     ■ The sample was in a person's physical possession and was then locked up or sealed to  
2       prevent tampering.
- 3     ■ The sample is kept in a secured area.

4 Chain-of-custody forms will be developed electronically and printed. An example chain-of-custody  
5 form is included as Appendix B of this QAPP. The sampling team members will fill out the date and  
6 time of sample collection in the field. When shipping the samples, the sampler will sign the bottom  
7 of the form and enter the date and time (24-hour) when samples were relinquished. The sampler  
8 will enter the carrier name and air bill number on the form. Any required special handling of  
9 analyzed samples, such as hold or return, must be written on the chain-of-custody record. A second  
10 member of the field crew will review the completed chain-of-custody record to confirm that  
11 required information is not omitted. The original signature copy of the chain-of-custody record will  
12 be enclosed in a plastic bag and secured to the inside of the cooler lid or shipping container. A copy  
13 of the chain-of-custody record will be retained for project files.

#### 14 **3.3.3.1       Laboratory Custody Procedures**

15 A designated sample custodian will accept the shipped samples and verify that the packing list  
16 sample numbers match those on the chain-of-custody records. Pertinent information regarding  
17 shipment, pickup, courier, and sample receipt information including temperature upon receipt at  
18 the laboratory will be entered in the section for remarks.

19 The laboratory sample custodian will reconcile the information on the chain-of-custody records  
20 with the information on the sample containers, as received. The laboratory sample custodian will  
21 document any anomalies and report these to the laboratory PM. Anomalies will be resolved with  
22 the project chemist. The laboratory sample custodian will email a copy of the cooler receipt form,  
23 the associated chain-of-custody records, and the sample delivery group assignment form to the PM  
24 and project chemist within 24 hours of sample receipt. The information on the forms will then be  
25 entered into the laboratory information management system along with the analyses being  
26 requested. USACE/VHA will be notified of any anomalies that may interfere with sample integrity.

27 The laboratory sample custodian is responsible for seeing that all samples are transferred to the  
28 proper analyst or stored in the appropriate secure area. Laboratory personnel are responsible for  
29 the care and custody of samples from the time they are received until the sample is exhausted or  
30 returned to the custodian using an internal chain-of-custody record to track sample movement  
31 within the laboratory. When sample analyses and necessary QA checks have been completed at the  
32 laboratory, the unused portion of the sample will be disposed of properly by the laboratory. All  
33 identifying stickers, data sheets, and laboratory records are retained as part of the laboratory  
34 documentation requirements listed in Section 2.6. Sample containers and remaining samples are  
35 disposed of in compliance with all federal, state, and local regulatory requirements.

#### 36 **3.3.4 Custody Seals**

37 Custody seals will be placed on coolers or shipping containers during transport of samples to the  
38 laboratory. The seals will be placed on two sides of the lid (one in front, and one on the side) and  
39 covered with tape to prevent inadvertent breaking of the seals. To prevent the opening of coolers  
40 during shipment and to confirm that the samples remain sealed under custody until arrival at the  
41 lab, an additional large liner bag (drum liner type) will be placed inside around the entire contents  
42 of cooler, tied tightly closed, and secured with additional custody seal.

### 3.3.5 Field Notebooks and Field Documentation

Field notebooks/logbooks are hardbound notebooks with pre-printed sequentially numbered pages in which all activities associated with the field investigation will be thoroughly described. Field notebooks are intended to provide sufficient data to reconstruct events occurring during the field project. SOP 4-1, *Field Logbook Content and Control*, and the FSP (Appendix A and Appendix A-1 of the RIWP [CH2M, 2018]) contain further information. General information regarding sampling activities will be recorded and includes, at a minimum, the following:

- Summary of daily activities, including information presented at the daily safety meeting
- Equipment onsite
- Descriptions of deviations from the FSP or QAPP
- Name and affiliation of all personnel or visitors onsite
- Weather conditions during the field activity
- Stop and start times for sampling activities at each location
- Description of any problems encountered during sampling at each location
- Other miscellaneous information that may be applicable to conditions encountered

In general, the various field documents are considered complementary in nature and of equal importance. However, in the event of direct conflicts or discrepancies among these documents, interpretations will generally be based on the following priorities:

1. Requirements for field documents, contained in contract documents or project documents (for example, work plans and this QAPP). Priority will be given to the most recent version of these documents or amendments to these documents.
2. Field documents chronologically filled out first, and from which data may be used in subsequent documents. For example, if a field form was used to record a water level that was subsequently also recorded in a field logbook.
3. Forms that were developed to capture specific information have precedence over documents, such as field logbooks, which are more general in nature.

There is not a rigid order of precedence for documents, as any discrepancies between documents will need to be evaluated on a case-by-case basis using best practices and professional judgement. However, the items noted above can be used as guidelines.

### 3.3.6 Corrections to Documentation

All original data recorded in field notebooks, sample identification tags, chain-of-custody records, and receipts-for-sample forms will be written with waterproof ink, unless prohibited by weather conditions. No accountable, serialized documents will be destroyed or disposed of, even if they are illegible or contain inaccuracies that require a replacement document.

If an error is made on an accountable document assigned to one team, the staff may make corrections simply by drawing a single line through the error, then entering the correct

1 information. The erroneous information should not be obliterated. Any subsequent error  
2 discovered on an accountable document should be corrected by the person who made the entry. All  
3 corrections must be initialed and dated with the date of correction by the person making the  
4 correction.

## 5 **3.4 Analytical Methods (B4)**

6 An analytical method identifies the procedures used to analyze samples and their required  
7 performance standards or criteria. This subsection contains brief descriptions of the field and  
8 laboratory analytical methods that will be used to analyze various media including soil, soil gas,  
9 surface water and groundwater samples.

### 10 **3.4.1 Field Analytical Methods**

11 Parameters measured in the field during surface water and groundwater sample collection include  
12 pH, specific conductance, turbidity, DO, oxidation-reduction potential, and temperature. In  
13 addition, field screening for VOCs using a portable GC/MS (HAPSITE) or PID will be used to  
14 measure concentrations of individual VOCs in soil gas and groundwater. Field analytical methods  
15 will be performed in accordance with the SOPs provided in Appendix A. The HAPSITE analyses will  
16 be performed according to the manufacturer's operating instructions provided in SOPs (Appendix  
17 A).

#### 18 **3.4.1.1 Specific Conductance**

19 The specific conductance of a sample will be measured by using a calibrated meter equipped with a  
20 flow-through cell, weighted screen, or sample cup.

#### 21 **3.4.1.2 Turbidity**

22 Routine calibration of the turbidity instrument will be performed according to the recommended  
23 manufacturer's calibration instructions.

#### 24 **3.4.1.3 pH**

25 Commercially prepared buffer solutions will be used for calibration. These solutions are certified  
26 with an accuracy of plus or minus 0.01 pH unit at a specific temperature, usually 25°C. Buffer  
27 solutions will not be used past the expiration date printed on the label. Buffer solutions used for  
28 instrument calibration will be stored in a separate container and replaced with new buffer  
29 solutions at least once per week.

#### 30 **3.4.1.4 Dissolved Oxygen**

31 The team will follow the manufacturer's specific instructions for the calibration, operation, and  
32 maintenance of the DO meter. The DO meter will be air calibrated daily in water-saturated air.

#### 33 **3.4.1.5 Oxidation-Reduction Potential**

34 Oxidation-reduction potential meters will be calibrated and used according to the manufacturer's  
35 guidelines.

#### 36 **3.4.1.6 Temperature**

37 The team will follow the manufacturer's specific instructions for the measurement of temperature  
38 using the multimeter.

### 3.4.1.7 Field Screening Portable GC/MS Method

A portable GC/MS will be used to measure concentrations of individual VOCs using EPA Method TO-15 as guidance for screening-level analyses of soil gas or headspace for purged groundwater samples. The portable GC/MS will be calibrated daily in accordance with the manufacturer's operating instructions provided in SOP *Analytical Method for the Determination of Volatile Organics in Air Using the HAPSITE Field GC/MS* (Appendix A). Use of the headspace sampling system for screening-level groundwater analysis using the HAPSITE is described in the SOP in Appendix A. HAPSITE method files and data files will be retained on the project drive. Project analytes, methods, and target detection limits are provided in Tables 2-8 and 2-9. Quality control measurement is provided in Table 3-2. In some cases (e.g. screening of soil cores), a PID may be used rather than the HAPSITE. The PID will be calibrated and used according to the manufacturer's guidelines.

### 3.4.2 Laboratory Analytical Methods

The laboratories will follow EPA or other industry standard applicable methodologies. Laboratory QA manuals and SOPs are provided in Appendixes C and D, respectively. Laboratory manuals and SOPs are referenced, but not provided for geotechnical analyses as they are standard ASTM methods. A laboratory QA manual and SOP are not provided for the magnetic susceptibility analysis because that is a proprietary method. An SOP is provided for the stable isotope method, which will be performed at the SIRFER laboratory at the University of Utah. With the exception of stable isotope analyses for water samples and geotechnical analyses for soil samples (which are not chemical analyses regulated under the CERCLA program), analyses will be performed by laboratories that can demonstrate method proficiency and are certified in the State of Utah (if the method is included in the state's certification program).

The turnaround time for laboratories will be 30 calendar days from sample receipt.

Project analytes, methods, and target laboratory detection limits are listed in Tables 2-3 through 2-13.

The following methods will be used for the project:

- **Metals – SW-846 Method 6020A, Inductively Coupled Plasma.** This method allows the multi-elemental determination of metals by transporting ions produced in the plasma into spectrometer. Interferences must be assessed and valid corrections must be applied.
- **Mercury – SW-846 Methods 7470A/7471A, Cold Vapor Atomic Absorption.** This technique is based on the absorption by mercury vapor. The mercury is reduced to the elemental state and aerated from solution in a closed system. The mercury vapor passes through a cell positioned in the light path of an atomic absorption spectrophotometer. Absorbance is measured as a function of mercury concentration.
- **Volatile Organic Analytic (VOA) – SW-846 Method 8260C, GC/MS.** The VOC GC/MS technique is used to quantitate most VOCs with boiling points below 200°C. Such compounds include low molecular weight halogenated hydrocarbons, aromatics, ketones, nitriles, acetates, acrylates, ethers, and sulfides.
- **Semivolatile VOA – SW-846 Method 8270D, GC/MS.** The SVOC GC/MS technique is used to quantitate most neutral, acidic, and basic organic compounds that are soluble in methylene chloride and capable of being eluted, without derivatization, as sharp peaks from a gas

- 1 chromatographic fused-silica capillary column coated with a slightly polar silicone. Such  
2 compounds include polynuclear aromatic hydrocarbons, chlorinated hydrocarbons and  
3 pesticides, phthalate esters, organophosphate esters, nitrosamines, haloethers, aldehydes,  
4 ethers, ketones, anilines, pyridines, quinolines, aromatic nitro compounds, and phenols  
5 including nitrophenols.
- 6 ■ **VOA – EPA Method TO-15, GC/MS.** Volatile organics in soil gas are collected in an evacuated  
7 Summa canister and analyzed using the GC/MS technique.
  - 8 ■ **Stable Oxygen and Hydrogen Isotopes.** Groundwater is analyzed using an autosampler and  
9 Picarro Cavity Ring-Down Spectroscopy system to determine  $\delta^{18}\text{O}$  and  $\delta^2\text{H}$  ratios.
  - 10 ■ **Ferrous Iron Mineral SM3500-Fe B4c.** Iron in soil is brought into solution and reduced to  
11 the ferrous state by boiling with acid and hydroxylamine. The solution is treated with 1,10-  
12 phenanthroline which chelates with ferrous iron to form an orange-red complex which is  
13 analyzed by spectroscopy.
  - 14 ■ **Dissolved Gases (Methane, Ethane, Ethene) – Method RSK-175, GC/Flame Ionization**  
15 **Detector.** Dissolved gases in water are sampled and analyzed uses GC coupled to a flame  
16 ionization detector and is able to detect methane, ethane, and ethene at low parts per billion  
17 levels.
  - 18 ■ **Total Organic Carbon – SW-846 Method 9060, Carbonaceous Analyzer.** Organic carbon  
19 in samples of groundwater is converted to either carbon dioxide and measured with an  
20 infrared detector, or to methane and measured with a flame ionization detector.
  - 21 ■ **Anions – EPA Method 300.0, Ion Chromatograph.** Common anions in water are  
22 determined by injecting a small portion of sample into the ion chromatograph equipped with  
23 a conductivity detector.
  - 24 ■ **Nitrate/Nitrite-N – Standard Methods SM4500-NO<sub>3</sub>E, Cadmium Reduction.** The nitrite,  
25 original and reduced, is determined by diazotizing with sulfanilamide/N-(1-naphthyl)-  
26 ethylenediamine dihydrochloride solution, which forms a highly colored azodye and is then  
27 measured spectrophotometrically.
  - 28 ■ **Alkalinity – Standard Methods 2320B, Titrimetric.** Alkalinity is determined by titrating a  
29 portion of the sample to an endpoint of pH 4.5 using hydrochloric acid.
  - 30 ■ **Total Dissolved Solids – Standard Methods 2540C, Gravimetric.** A well-mixed sample is  
31 filtered through a standard glass fiber filter. The filtrate is evaporated and dried to constant  
32 weight at 180°C.
  - 33 ■ **Total Sulfide – Standard Methods 4500S2-CF, Iodometric Titration.** The sample is  
34 pretreated to remove interfering substances. The sample is titrated with sodium thiosulfate  
35 until disappearance of elementary iodine indicates the end point.
  - 36 ■ **Fraction of Organic Carbon – ASTM D2974.** The fraction of organic carbon is measured by  
37 drying the sample at 440°C.

- 1     ■ **Magnetic Susceptibility – Microbial Insights Laboratory Method.** A proprietary method  
2       utilizing a Bartington magnetic susceptibility system to assess the magnetic susceptibility of  
3       soil samples.
- 4     ■ **Sieve Analysis – ASTM D6913.** Particle size measurement for particles larger than fine-  
5       grained (silt/clay) soils.
- 6     ■ **Dry Bulk Soil Density – ASTM D2937.** Measurement of in-situ dry density, used to calculate  
7       porosity and other geotechnical parameters.
- 8     ■ **Hydrometer – ASTM D422a.** Measurement of particle size of fine-grained (silt/clay)  
9       particles.
- 10    ■ **Unified Soil Classification System Soil Classification – ASTM D2487.** Standard soil  
11      classification system.
- 12    ■ **Atterberg Limits – ASTM D4318.** Measurement of plasticity of the soil, required for the  
13      USCS.
- 14    ■ **Gradation – ASTM D1140.** Test to measure percent of total soil sample that is silt/clay  
15      sized, by wet (washing) sieve.
- 16    ■ **Vertical Permeability – ASTM D2434.** Measurement of permeability on an undisturbed soil  
17      sample, using a constant-head method.
- 18    ■ **Moisture Content – ASTM D2216.** The gravimetric (wt/wt) percent of water in a soil  
19      sample.

## 20    3.5   Quality Control (B5)

21    The QC samples and procedures document compliance with objectives or demonstrate the need for  
22    corrective action. Checks controlling field activities (for example, sample collection and shipping)  
23    and checks controlling laboratory activities (for example, digestion and analysis) are used. These  
24    checks are discussed in the following subsections. The numbers of QC samples associated with  
25    each sample medium, and details regarding their collection, are provided in Section 5.12 of the FSP  
26    (Appendix A-1 of the RIWP [CH2M, 2018]).

### 27    3.5.1   Field Quality Control Procedures

28    The QC samples are collected in the field and used to evaluate the validity of the field sampling  
29    effort. Field QC samples are collected for laboratory analysis when appropriate to check sampling  
30    and analytical precision, accuracy, and representativeness. With the exception of FDs for fraction of  
31    organic carbon and magnetic susceptibility, field QC samples will not be collected for any  
32    geotechnical analyses. Field QC samples for stable isotope samples will be limited to FDs. The  
33    following subsections discuss the types and purposes of field QC samples that will be collected.

#### 34    3.5.1.1    Field Blanks

35    Field blanks are used to evaluate potential for ambient background cross-contamination of sampled  
36    media. The ASTM Type II water (purchased and certified from a commercial vendor) will be  
37    poured directly from its original container into laboratory supplied sample containers for analysis.  
38    Field blanks will be collected at a minimum frequency of 1 per 20 samples collected or 1 per day



1 when fewer than 20 samples are collected. No field blanks will be collected for soil gas samples  
2 (EPA Method TO-15).

### 3 **3.5.1.2 Equipment Rinsate Blanks**

4 Equipment rinsate blanks are used to evaluate sampling device cleanliness. Rinsate blanks are  
5 collected after a sample collection device is subjected to standard decontamination procedures.  
6 ASTM Type II water (purchased and certified from a commercial vendor) will be poured over or  
7 through the sampling device and collected in a sample container for analysis. Equipment rinsate  
8 blanks will be collected at a minimum frequency of 1 per 20 samples collected or 1 per day when  
9 fewer than 20 samples are collected. No equipment rinsate blanks will be collected for soil gas  
10 samples (EPA Method TO-15).

### 11 **3.5.1.3 Trip Blanks**

12 The trip blank consists of a VOC sample vial filled in the laboratory with ASTM Type II reagent  
13 grade or organic-free water, transported to the sampling site, handled like an environmental  
14 sample, and returned to the laboratory for analysis. Trip blanks are not opened in the field. Trip  
15 blanks are prepared only when VOC samples are collected and analyzed for VOC analytes. No trip  
16 blanks will be collected for soil gas samples (EPA Method TO-15).

17 Trip blanks are used to assess the potential introduction of contaminants from sample containers  
18 or during the transportation and storage procedures. Each cooler of samples sent to the laboratory  
19 for analysis of VOCs will contain one trip blank. When an analyte is detected in the trip blank, the  
20 appropriate flag will be applied to all VOC sample results from samples in the cooler with the  
21 affected trip blank.

### 22 **3.5.1.4 Field Duplicates**

23 A FD sample is collected at the same time and from the same source as the original sample, but  
24 submitted to the laboratory as a separate sample to assess the consistency of the overall sampling  
25 and analytical system. Water, soil, and soil gas FDs will be collected and analyzed on a 10 percent  
26 basis for all analytical laboratory methods or a minimum of 1 per sampling event (defined as a  
27 shipment of samples to the laboratory under one chain-of-custody) if fewer than 10 samples are  
28 collected. Field duplicate samples will be collected, numbered, packaged, sealed in the same  
29 manner as other samples, and submitted blind to the laboratories.

### 30 **3.5.1.5 Temperature Blank**

31 All coolers with samples that require preservation to 4°C will contain at least one temperature  
32 blank. The temperature blank should be a 40-milliliter glass vial filled with water and placed in a  
33 representative position inside the cooler. Each vial will be clearly marked TEMPERATURE BLANK.  
34 If the temperature blank is positioned inappropriately or is not representative of the cooler  
35 temperature measurement, the laboratory will document the deficiency and notify the PM.

## 36 **3.5.2 Laboratory Quality Control Procedures**

37 Laboratory QC checks are designed to determine the precision and accuracy of the analysis, to  
38 demonstrate the absence of interference and contamination from glassware and reagents, and to  
39 allow data comparability. Laboratory QC checks consist of method blanks, LCSs, MSs, MSDs, and  
40 laboratory duplicates. In addition, post digestion spike, serial dilution, and interference check  
41 samples will be evaluated for metals analysis only, and surrogates and internal standards will be  
42 evaluated for those methods where applicable (for example, organic methods only). The laboratory



1 will also complete initial calibrations and continuing calibration checks according to specified  
2 analytical methods. Each QC check and their frequencies are discussed in the following subsections.  
3 Precision and accuracy goals for laboratory analytical methods are listed in Tables 3-3 through 3-  
4 12.

### 5 **3.5.2.1 Method Blanks**

6 Method blanks are designed to detect contamination of the field samples in the laboratory  
7 environment. Method blanks verify that interferences caused by contaminants in solvents,  
8 reagents, glassware, or in other sample processing hardware are known and minimized. The  
9 method blank will be ASTM Type II water (or equivalent) for water samples and a clean soil matrix  
10 (such as Ottawa sand) for soil samples. If the blank contaminant concentration is not less than the  
11 reporting limit, the source of contamination will be identified and corrective action will be taken  
12 before sample reanalysis. Analytical data will not be corrected for the presence of analytes in  
13 blanks. Analytical results for each sample will be clearly associated with a particular method blank.  
14 Method blanks are performed per laboratory batch per analytical method.

### 15 **3.5.2.2 Matrix Spikes/Matrix Spike Duplicates**

16 MSs and MSDs are aliquots of a sample spiked with known concentrations of all target analytes.  
17 The spiking occurs during sample preparation and before analysis. Each analyte in the MS and MSD  
18 will be spiked at a level less than or equal to the midpoint of the calibration curve for each analyte.  
19 Collection of a volume of sample adequate for running analyses in triplicate is required for  
20 MS/MSDs. Therefore, the MS/MSD will be designated on the chain-of-custody documentation.

21 A minimum of one MS and one MSD will be designated by the PM for each site and included for  
22 every 20 field samples, for applicable methods. MS/MSDs are not performed for EPA Method  
23 TO-15.

### 24 **3.5.2.3 Laboratory Duplicates**

25 A laboratory duplicate sample is a second and separate analysis of a field sample used to determine  
26 the precision of the analytical method relative to the sample matrix. Laboratory duplicate samples  
27 may be analyzed with or without an MS sample, depending on the laboratory SOP.

### 28 **3.5.2.4 Post Digestion Spike**

29 A post-digestion spike is a portion of the sample digestate that is fortified with known quantities of  
30 compounds of interest. The post-digestion spike is used to measure either positive or negative  
31 interferences that may distort the accuracy of the reported values in the native sample. Accuracy of  
32 the analytes should be within 75 to 125 percent of the known concentration added. Post-digestion  
33 spikes are only evaluated for metals analyses.

### 34 **3.5.2.5 Serial Dilution**

35 A 1 to 5 serial dilution is performed on a portion of the sample digestate and analyzed. The serial  
36 dilution is used to measure either positive or negative interferences that may distort the precision  
37 of the reported values in the native sample. Precision is expressed in terms of the percent  
38 difference (%D) between the original sample and the serial dilution results. The %D criterion  
39 should be less than 10 percent if the concentration of the analyte in the original sample is greater  
40 than 50 times the MDL. Serial dilutions are only evaluated for metals analyses

1 **3.5.2.6 Interference Check Sample**

2 The interference check samples are used in inductively coupled plasma analyses (for example,  
3 metals analyses) to verify background and inter-element correction factors. They consist of two  
4 solutions: A and B. Solution A contains the interfering analytes, and Solution B contains both the  
5 analytes of interest and the interfering analytes. Both solutions are analyzed at the beginning and  
6 at the end of each analytical sequence. When the interference check samples results are outside the  
7 method-specified control limits, corrective action must be taken, including sample reanalysis, if  
8 appropriate.

9 **3.5.2.7 Laboratory Control Samples**

10 The LCSs are blank spikes made from clean laboratory-simulated matrices spiked with known  
11 concentrations of all target analytes of interest. The LCS is carried through the complete sample  
12 preparation and analysis procedure. LCSs are designed to check the instrument and method  
13 accuracy. An LCS will be analyzed with every analytical batch. Failure of the LCS to meet %R  
14 criteria for any compound requires corrective action specified in Tables 3-3 through 3-12. If  
15 corrective action specifies re-extraction and reanalysis, all samples associated with the out-of-  
16 control LCS must be re-extracted and reanalyzed after control is reestablished. All re-extraction  
17 and re-analysis must be performed within the sample holding times. If corrective action was  
18 unsuccessful or not performed, the data will be qualified for the affected analytes.

19 **3.5.2.8 Surrogates**

20 Surrogates are compounds similar to the target analyte(s) in chemical composition and behavior in  
21 the analytical process but not normally found in environmental samples. Surrogates are used to  
22 evaluate accuracy, method performance, and extraction efficiency for organic methods only.  
23 Surrogates will be added to environmental samples, controls, and blanks, in accordance with the  
24 method requirements. Whenever a surrogate recovery is outside the acceptance limit, corrective  
25 action as outlined in Tables 3-3 through 3-12, where applicable, must be performed.

26 **3.5.2.9 Internal Standards**

27 Internal standards are compounds added to every GC/MS standard, method blank, LCS/LCS  
28 duplicate, MS/MSD, and sample extract at a known concentration before instrument analysis for  
29 organic methods only. They are used to quantify the target analytes. Internal standards provide for  
30 stable sensitivity and response during every analytical run. An internal standard is used to evaluate  
31 the efficiency of the sample introduction process and monitor the efficiency of the analytical  
32 procedure for each sample matrix encountered.

**Table 3-2. Quality Control Samples for Field Screening of Volatile Organic Compounds in Soil Gas/Water (HAPSITE)**  
*Quality Assurance Project Plan, OU-2 Remedial Investigation 700 South 1600 East PCE Plume, Salt Lake City, Utah*

| <b>QC Sample:</b>                | <b>Frequency/ Number</b>      | <b>Method/SOP QC Acceptance Limits</b>   | <b>Corrective Action</b>  | <b>Person(s) Responsible for Corrective Action</b> | <b>Data Quality Indicator</b> | <b>Measurement Performance Criteria</b>  |
|----------------------------------|-------------------------------|--|---|--|-------------------------------|--|
| Daily Calibration Check Standard | Daily, before sample analysis | % Recovery = 70-130%   | Rerun, investigate source of problems. Recalibrate instrument if rerun does not meet QC acceptance limits | Field Technician                                   | Accuracy                      | % Recovery = 70-130%   |
| System Blank                     | Daily, before sample analysis | Target analytes: < RL  | Rerun, maintenance.   | Field Technician                                   | Accuracy – Contamination      | Target analytes: < RL  |
| Internal Standards               | Each field and QC sample      | IS area -50% to +100% compared to IS from Daily Calibration Check Standard<br><br>IS RT window ±0.5 minutes compared to CCV RT | Reanalyze affected samples. If similar results, report both runs. Flag data                               | Field Technician                                   | Accuracy                      | IS area -50% to +100% compared to IS from Daily Calibration Check Standard<br><br>IS RT window ±0.5 minutes compared to CCV RT |

**Table 3-3. Quality Control Samples (Field and Lab) for Volatile Organic Compounds in Soil and Water**

*Quality Assurance Project Plan, OU-2 Remedial Investigation 700 South 1600 East PCE Plume, Salt Lake City, Utah*

| <b>QC Sample</b>          | <b>Frequency/ Number</b>                                    | <b>Method/SOP QC Acceptance Limits</b>   | <b>Corrective Action</b>   | <b>Person(s) Responsible for Corrective Action</b> | <b>Data Quality Indicator</b> | <b>Measurement Performance Criteria</b>  |
|---------------------------|---|--|--|--|-------------------------------|--|
| Method Blank              | One per prep batch of 20 or fewer samples of similar matrix | Target analytes < 50% RL except for common laboratory contaminants < RL                            | Investigate source of contamination. Rerun method blank. No samples may be run until an acceptable method blank has been run   | Laboratory Supervisor                              | Accuracy                      | Target analytes < 50% RL except for common laboratory contaminants < RL                            |
| Laboratory Control Sample | One per batch of 20 or fewer samples of similar matrix      | Recovery within QC limits as defined in Table 3-4  | Re-prepare sample and re-analyze, if recovery is high and sample is < RL narrate   | Laboratory Supervisor / Data Validator             | Accuracy                      | Recovery within QC limits as defined in Table 3-4  |
| Matrix Spike              | One per batch of 20 or fewer samples of similar matrix      | Recovery within QC limits as defined in Table 3-4  | If recoveries are outside limits and surrogate criteria are met, note in narrative. If both the surrogate and MS/MSD are unacceptable, re-prepare the samples and QC. Check standard prep. Flag data | Laboratory Supervisor / Data Validator             | Accuracy                      | Recovery within QC limits as defined in Table 3-4  |
| Matrix Spike Duplicate    | One per batch of 20 or fewer samples of similar matrix      | Recovery within QC limits as defined in Table 3-4  | Same as MS   | Laboratory Supervisor / Data Validator             | Accuracy and Precision        | Recovery within QC limits as defined in Table 3-4  |
| Internal Standards        | Each field and QC sample                                    | IS area -50% to +100% compared to IS from CCV<br>IS RT window $\pm 0.5$ minutes compared to CCV RT | Reanalyze affected samples. If similar results, report both runs. Flag data  | Laboratory Supervisor / Data Validator             | Accuracy                      | IS area -50% to +100% compared to IS from CCV<br>IS RT window $\pm 0.5$ minutes compared to CCV RT |

**Table 3-3. Quality Control Samples (Field and Lab) for Volatile Organic Compounds in Soil and Water**

*Quality Assurance Project Plan, OU-2 Remedial Investigation 700 South 1600 East PCE Plume, Salt Lake City, Utah*

| QC Sample          | Frequency/ Number             | Method/SOP QC Acceptance Limits                                    | Corrective Action   | Person(s) Responsible for Corrective Action | Data Quality Indicator | Measurement Performance Criteria   |
|--------------------|-------------------------------|--|---|---|------------------------|--|
| Surrogate Standard | Every sample                  | All surrogate recoveries within laboratory specified QC limits     | If sample volume available, reanalyze. Report both if second successful analysis is outside hold time or both fail QC criteria. Flag data | Laboratory Supervisor / Data Validator      | Accuracy               | All surrogate recoveries within laboratory specified QC limits             |
| Field Duplicates   | One per 10 per matrix         | RPD < 30% (aq), < 50% (solids) for compounds w/ concentration > RL | Evaluate batch precision, other FD results<br>Note in validation report   | Data Validator                              | Precision              | RPD < 30% (aq), < 50% (solids) for compounds w/ concentration > RL         |
| Equipment Blank    | Collected daily               | Results < RL   | Evaluate sample results; flag data as necessary review decontamination procedures   | Data Validator                              | Accuracy               | Results < RL unless target analytes in field samples are > 10x those in EB |
| Trip Blank         | One per shipment aqueous VOCs | Results < RL   | Evaluate sample results; flag data as necessary   | Data Validator                              | Accuracy               | Results < RL unless target analytes in field samples are > 10x those in EB |

Notes:

aq = aqueous  
 CCV = continuing calibration verification  
 EB = equipment blank  
 FD = field duplicate  
 IS = internal standard  
 MS = matrix spike  
 MSD = matrix spike duplicate  
 QC = quality control  
 RL = reporting limit  
 RPD = relative percent difference  
 RT = retention time  
 SOP = standard operating procedure  
 VOC = volatile organic compound

**Table 3-4. Precision and Accuracy for Volatile Organic Compounds in Soil and Water***Quality Assurance Project Plan, OU-2 Remedial Investigation 700 South 1600 East PCE Plume, Salt Lake City, Utah*

| Analyte   | Method  | Soil MS/MSD<br>% Recovery <sup>a</sup> | Soil LCS %<br>Recovery <sup>a</sup> | RPD <sup>b</sup> | Water MS/MSD<br>% Recovery <sup>a</sup> | Water LCS %<br>Recovery <sup>a</sup> | RPD <sup>b</sup> |
|---|---------|--|-------------------------------------|------------------|---|--------------------------------------|------------------|
| 1,1,1-Trichloroethane                             | SW8260C | 73 - 125                               | 73 - 125                            | 30               | 74 - 131                                | 74 - 131                             | 20               |
| 1,1,2,2-Tetrachloroethane                         | SW8260C | 70 - 124                               | 70 - 124                            | 30               | 71 - 121                                | 71 - 121                             | 20               |
| 1,1,2-Trichloro-1,2,2-trifluoroethane (Freon 113) | SW8260C | 66 - 136                               | 66 - 136                            | 30               | 70 - 136                                | 70 - 136                             | 20               |
| 1,1,2-Trichloroethane                             | SW8260C | 78 - 121                               | 78 - 121                            | 30               | 80 - 119                                | 80 - 119                             | 20               |
| 1,1-Dichloroethane                                | SW8260C | 76 - 125                               | 76 - 125                            | 30               | 77 - 125                                | 77 - 125                             | 20               |
| 1,1-Dichloroethene                                | SW8260C | 70 - 131                               | 70 - 131                            | 30               | 71 - 131                                | 71 - 131                             | 20               |
| 1,2,3-Trichlorobenzene                            | SW8260C | 66 - 130                               | 66 - 130                            | 30               | 69 - 129                                | 69 - 129                             | 20               |
| 1,2,4-Trichlorobenzene                            | SW8260C | 67 - 129                               | 67 - 129                            | 30               | 69 - 130                                | 69 - 130                             | 20               |
| 1,2,4-Trimethylbenzene                            | SW8260C | 75 - 123                               | 75 - 123                            | 30               | 76 - 124                                | 76 - 124                             | 20               |
| 1,3,5-Trimethylbenzene                            | SW8260C | 73 - 124                               | 73 - 124                            | 30               | 75 - 124                                | 75 - 124                             | 20               |
| 1,2-Dibromo-3-Chloropropane                       | SW8260C | 61 - 132                               | 61 - 132                            | 30               | 62 - 138                                | 62 - 138                             | 20               |
| 1,2-Dibromoethane                                 | SW8260C | 78 - 122                               | 78 - 122                            | 30               | 77 - 121                                | 77 - 121                             | 20               |
| 1,2-Dichlorobenzene                               | SW8260C | 78 - 121                               | 78 - 121                            | 30               | 80 - 119                                | 80 - 119                             | 20               |
| 1,2-Dichloroethane                                | SW8260C | 73 - 128                               | 73 - 128                            | 30               | 73 - 128                                | 73 - 128                             | 20               |
| 1,2-Dichloropropane                               | SW8260C | 76 - 123                               | 76 - 123                            | 30               | 78 - 122                                | 78 - 122                             | 20               |
| 1,3-Dichlorobenzene                               | SW8260C | 77 - 121                               | 77 - 121                            | 30               | 80 - 119                                | 80 - 119                             | 20               |
| 1,4-Dichlorobenzene                               | SW8260C | 75 - 120                               | 75 - 120                            | 30               | 79 - 118                                | 79 - 118                             | 20               |
| 2-Butanone (Methyl Ethyl Ketone)                  | SW8260C | 51 - 148                               | 51 - 148                            | 30               | 56 - 143                                | 56 - 143                             | 20               |
| 2-Hexanone  | SW8260C | 53 - 145                               | 53 - 145                            | 30               | 57 - 139                                | 57 - 139                             | 20               |
| 4-Methyl-2-pentanone                              | SW8260C | 65 - 135                               | 65 - 135                            | 30               | 67 - 130                                | 67 - 130                             | 20               |
| Acetone   | SW8260C | 36 - 164                               | 36 - 164                            | 30               | 39 - 160                                | 39 - 160                             | 20               |
| Benzene   | SW8260C | 77 - 121                               | 77 - 121                            | 30               | 79 - 120                                | 79 - 120                             | 20               |

**Table 3-4. Precision and Accuracy for Volatile Organic Compounds in Soil and Water**

*Quality Assurance Project Plan, OU-2 Remedial Investigation 700 South 1600 East PCE Plume, Salt Lake City, Utah*

| Analyte                            | Method  | Soil MS/MSD<br>% Recovery <sup>a</sup> | Soil LCS %<br>Recovery <sup>a</sup> | RPD <sup>b</sup> | Water MS/MSD<br>% Recovery <sup>a</sup> | Water LCS %<br>Recovery <sup>a</sup> | RPD <sup>b</sup> |
|------------------------------------|---------|--|-------------------------------------|------------------|---|--------------------------------------|------------------|
| Bromochloromethane                 | SW8260C | 78 - 125                               | 78 - 125                            | 30               | 78 - 120                                | 78 - 120                             | 20               |
| Bromodichloromethane               | SW8260C | 75 - 127                               | 75 - 127                            | 30               | 79-125                                  | 79-125                               | 20               |
| Bromoform                          | SW8260C | 67 - 132                               | 67 - 132                            | 30               | 66-130                                  | 66-130                               | 20               |
| Bromomethane                       | SW8260C | 53 - 143                               | 53 - 143                            | 30               | 53-141                                  | 53-141                               | 20               |
| Carbon Disulfide                   | SW8260C | 63 - 132                               | 63 - 132                            | 30               | 64-133                                  | 64-133                               | 20               |
| Carbon Tetrachloride               | SW8260C | 70 - 135                               | 70 - 135                            | 30               | 72-136                                  | 72-136                               | 20               |
| Chlorobenzene                      | SW8260C | 79 - 120                               | 79 - 120                            | 30               | 82-118                                  | 82-118                               | 20               |
| Chloroethane                       | SW8260C | 59 - 139                               | 59 - 139                            | 30               | 60-138                                  | 60-138                               | 20               |
| Chloroform                         | SW8260C | 78 - 123                               | 78 - 123                            | 30               | 79-124                                  | 79-124                               | 20               |
| Chloromethane                      | SW8260C | 50 - 136                               | 50 - 136                            | 30               | 50-139                                  | 50-139                               | 20               |
| cis-1,2-Dichloroethene             | SW8260C | 77 - 123                               | 77 - 123                            | 30               | 78-123                                  | 78-123                               | 20               |
| Dibromochloromethane               | SW8260C | 74 - 126                               | 74 - 126                            | 30               | 74-126                                  | 74-126                               | 20               |
| Dichlorodifluoromethane (Freon 12) | SW8260C | 29 - 149                               | 29 - 149                            | 30               | 32-152                                  | 32-152                               | 20               |
| Ethylbenzene                       | SW8260C | 76 - 122                               | 76 - 122                            | 30               | 79-121                                  | 79-121                               | 20               |
| Isopropylbenzene (Cumene)          | SW8260C | 68 - 134                               | 68 - 134                            | 30               | 72-131                                  | 72-131                               | 20               |
| Methyl acetate                     | SW8260C | 53 - 144                               | 53 - 144                            | 30               | 56-136                                  | 56-136                               | 20               |
| Methyl Tert-Butyl Ether            | SW8260C | 73 - 125                               | 73 - 125                            | 30               | 71-124                                  | 71-124                               | 20               |
| Methylene chloride                 | SW8260C | 70 - 128                               | 70 - 128                            | 30               | 74-124                                  | 74-124                               | 20               |
| m,p-Xylene                         | SW8260C | 77 - 124                               | 77 - 124                            | 30               | 80-121                                  | 80-121                               | 20               |
| o-Xylene                           | SW8260C | 77 - 123                               | 77 - 123                            | 30               | 78-122                                  | 78-122                               | 20               |
| Styrene                            | SW8260C | 76 - 124                               | 76 - 124                            | 30               | 78-123                                  | 78-123                               | 20               |
| Tetrachloroethene                  | SW8260C | 73 - 128                               | 73 - 128                            | 30               | 74-129                                  | 74-129                               | 20               |

**Table 3-4. Precision and Accuracy for Volatile Organic Compounds in Soil and Water**

*Quality Assurance Project Plan, OU-2 Remedial Investigation 700 South 1600 East PCE Plume, Salt Lake City, Utah*

| Analyte                                      | Method  | Soil MS/MSD<br>% Recovery <sup>a</sup> | Soil LCS %<br>Recovery <sup>a</sup> | RPD <sup>b</sup> | Water MS/MSD<br>% Recovery <sup>a</sup> | Water LCS %<br>Recovery <sup>a</sup> | RPD <sup>b</sup> |
|--|---------|--|-------------------------------------|------------------|---|--------------------------------------|------------------|
| Toluene                                      | SW8260C | 77 - 121                               | 77 - 121                            | 30               | 80-121                                  | 80-121                               | 20               |
| Total 1,3-dichloro propene (cis- and trans-) | SW8260C | 71 - 130                               | 71 - 130                            | 30               | 77-123                                  | 77-123                               | 20               |
| trans-1,2-Dichloroethene                     | SW8260C | 74 - 125                               | 74 - 125                            | 30               | 75-124                                  | 75-124                               | 20               |
| Trichloroethene                              | SW8260C | 77 - 123                               | 77 - 123                            | 30               | 79-123                                  | 79-123                               | 20               |
| Trichlorofluoromethane (Freon 11)            | SW8260C | 62 - 140                               | 62 - 140                            | 30               | 65-141                                  | 65-141                               | 20               |
| Vinyl Acetate                                | SW8260C | 50 - 151                               | 50 - 151                            | 30               | 54 - 146                                | 54 - 146                             | 20               |
| Vinyl Chloride                               | SW8260C | 56 - 135                               | 56 - 135                            | 30               | 58-137                                  | 58-137                               | 20               |

<sup>a</sup> LCS and MS/MSD limits based on DoD QSM Version 5.1, Appendix C (DoD, 2017)

<sup>b</sup> RPDs are applicable to both MS/MSD and LCS

Notes:

% = percentage

DoD = U.S. Department of Defense

LCS = laboratory control samples

LCS D = laboratory control sample duplicate

MS/MSD = matrix spike/matrix spike duplicate

QSM = quality systems manual

RPD = relative percent difference



**Table 3-5. Quality Control Samples (Field and Lab) for Semivolatile Organic Compounds in Soil and Water**

*Quality Assurance Project Plan, OU-2 Remedial Investigation 700 South 1600 East PCE Plume, Salt Lake City, Utah*

| QC Sample                 | Frequency/Number  | Method/SOP QC Acceptance Limits   | Corrective Action   | Person(s) Responsible for Corrective Action | Data Quality Indicator) | Measurement Performance Criteria   |
|---------------------------|---|---|---|---|-------------------------|--|
| Method Blank              | One per prep batch of 20 or fewer samples of similar matrix | Target analytes < 50% RL except for common laboratory contaminants < RL                       | Investigate source of contamination. Rerun method blank. If MB still fails acceptance limits, re-prepare/reanalyze method blank and associated samples. No samples may be run until an acceptable method blank has been run | Laboratory Supervisor                       | Accuracy                | Target analytes < 50% RL<br><br>Except for common laboratory contaminants < RL unless target analytes in field samples are > 10× those in method blank |
| Laboratory Control Sample | One per batch of 20 or fewer samples of similar matrix      | Recovery within QC limits as defined in Table 3-6   | Re-prepare sample and reanalyze, if recovery is high and sample is < RL narrate   | Laboratory Supervisor / Data Validator      | Accuracy                | Recovery within QC limits as defined in Table 3-6  |
| Matrix Spike              | One per batch of 20 or fewer samples of similar matrix      | Recovery within QC limits as defined in Table 3-6   | If recoveries are outside limits and surrogate criteria are met, note in narrative. If both the surrogate and MS/MSD are unacceptable, re-prepare the samples and QC. Check standard prep. Flag data                        | Laboratory Supervisor / Data Validator      | Accuracy                | Recovery within QC limits as defined in Table 3-6  |
| Matrix Spike Duplicate    | A minimum of one per batch or one per 20 per matrix         | Recovery within QC limits as defined in Table 3-6   | Same as MS  | Laboratory Supervisor / Data Validator      | Accuracy and Precision  | Recovery within QC limits as defined in Table 3-6  |
| Internal Standards        | Each field and QC sample                                    | IS area -50% to +100% compared to IS from CCV<br>IS RT window ±0.5 minutes compared to CCV RT | Reanalyze affected samples. If similar results, report both runs. Flag outliers   | Laboratory Supervisor / Data Validator      | Accuracy                | IS area -50% to +100% compared to IS from CCV<br><br>IS RT window ±0.5 minutes compared to CCV RT  |

**Table 3-5. Quality Control Samples (Field and Lab) for Semivolatile Organic Compounds in Soil and Water**

*Quality Assurance Project Plan, OU-2 Remedial Investigation 700 South 1600 East PCE Plume, Salt Lake City, Utah*

| QC Sample        | Frequency/Number                                 | Method/SOP QC Acceptance Limits                                  | Corrective Action   | Person(s) Responsible for Corrective Action | Data Quality Indicator) | Measurement Performance Criteria  |
|------------------|--|--|---|---|-------------------------|---|
| Surrogates       | Every Sample                                     | Recoveries within laboratory specified QC control limits;        | If sample volume available, re-extract. Report both if second successful analysis is outside Holding Time or both fail QC criteria. Flag data | Analyst, Supervisor, Laboratory QA Manager  | Accuracy                | All surrogate recoveries within laboratory specified QC control limits; one acid-extractable compound, one base-neutral compound can be out if >10% |
| Field Duplicates | One per 10 per matrix; minimum of one per matrix | RPD < 30% (aq), <50% (solid) for compounds w/ concentration > RL | Evaluate batch precision, other FD results<br>Note in validation report   | Data Validator                              | Precision               | RPD < 30% (aq), <50% (solid) for compounds w/ concentration > RL  |
| Equipment Blank  | Collected daily                                  | Results < RL   | Evaluate sample results; flag data as necessary<br>Review decontamination procedures  | Data Validator                              | Accuracy                | Results < RL unless target analytes in field samples are >10x those in EB   |

Notes:

aq = aqueous

CCV = continuing calibration verification

EB = equipment blank

FD = field duplicate

IS = internal standard

MB = method blank

MS = matrix spike

MSD = matrix spike duplicate

QA = quality assurance

QC = quality control

RL = reporting limit

RPD = relative percent difference

RT = retention time

SOP = standard operating procedure

VOC = volatile organic compound

**Table 3-6. Precision and Accuracy for Semivolatile Organic Compounds in Soil and Water**

*Quality Assurance Project Plan, OU-2 Remedial Investigation 700 South 1600 East PCE Plume, Salt Lake City, Utah*

| Analyte     | Method  | Soil MS/MSD % Recovery <sup>a</sup> | Soil LCS % Recovery <sup>a</sup> | RPD <sup>b</sup> | Water MS/MSD % Recovery <sup>a</sup> | Water LCS % Recovery <sup>a</sup> | RPD <sup>b</sup> |
|-------------|---------|-------------------------------------|----------------------------------|------------------|--------------------------------------|-----------------------------------|------------------|
| 1,4-Dioxane | SW8270D | c                                   | c                                | 30               | c                                    | c                                 | 20               |

<sup>a</sup> LCS and MS/MSD limits based on DoD QSM Version 5.1, Appendix C (DoD, 2017)

<sup>b</sup> RPDs are applicable to both MS/MSD and LCS/LCSD

<sup>c</sup> Will use laboratory limits

Notes:

DoD = U.S. Department of Defense

LCS = laboratory control samples

LCSD = laboratory control sample duplicate

MS/MSD = matrix spike/matrix spike duplicate

RPD = relative percent difference

**Table 3-7. Quality Control Samples (Field and Lab) for Metals in Soil and Water**

*Quality Assurance Project Plan, OU-2 Remedial Investigation 700 South 1600 East PCE Plume, Salt Lake City, Utah*

| QC Sample                           | Frequency/ Number   | Method/SOP QC Acceptance Limits                                 | Corrective Action  | Person(s) Responsible for Corrective Action | Data Quality Indicator | Measurement Performance Criteria  |
|-------------------------------------|---|---|--|---|------------------------|---|
| Preparation Blank                   | One per prep batch of 20 or fewer samples of similar matrix       | Target analytes < 50% RL; common contaminants < RL              | Redigest and re-analyze, if sample concentration is > 10× blank concentration narrate. | Laboratory Supervisor                       | Accuracy               | Target analytes < 50% RL, common contaminants < RL; unless target analytes in field samples are > 10× those in method blank |
| Interference Check Sample (A and B) | At beginning and end of instrument run and after every 20 samples | ICS-A: Unspiked analytes < RL<br>ICS-AB: % Recovery 80% -120%   | Reanalyze samples analyzed after last acceptable ICS-A/ICS-AB                          | Laboratory Supervisor                       | Accuracy               | ICS-A: Unspiked analytes < RL<br>ICS-AB: % Recovery 80% - 120%  |
| Serial Dilution                     | One per prep batch of 20 or fewer samples of similar matrix       | % Difference 10% if sample concentration > 50× MDL              | Perform PDS, Qualify data  | Laboratory Supervisor/<br>Data Validator    | Accuracy               | % Difference 10% if sample concentration > 50× MDL  |
| Laboratory Control Sample           | One per prep batch of 20 or fewer samples of similar matrix       | Recovery within QC limits as defined in Table 3-8               | Redigest and re-analyze, if recovery is high and sample is < RL narrate                | Laboratory Supervisor                       | Accuracy               | Defined in Table 3-8  |
| Laboratory Duplicate                | One per prep batch of 20 or fewer samples of similar matrix       | RPD ≤ 20% if sample concentration > 5×RL, if < 5×RL             | Check instrument performance, qualify data   | Laboratory Supervisor/<br>Data Validator    | Precision              | Values ≥5×RL: RPD ±20%<br>Values < 5×RL: ±5×RL  |
| Matrix Spike Sample                 | One per prep batch of 20 or fewer samples of similar matrix       | % Recovery See Table 3-8  | Perform post-digestion spike analysis, qualify data                                    | Laboratory Supervisor/<br>Data Validator    | Accuracy               | Recovery ±25% of true value if sample < 4× spike value  |
| Post-Digestion Spike                | For elements outside of QC limits in Matrix Spike                 | % Recovery 80% - 120%   | Check instrument performance, qualify data   | Laboratory Supervisor/<br>Data Validator    | Accuracy               | Recovery ±25% of true value   |
| Internal Standards <sup>a</sup>     | Each field and QC sample <sup>a</sup>                             | Percent relative intensity of each IS standard within 60 – 125% | Reanalyze samples after 2-fold dilution  | Laboratory Supervisor                       | Accuracy               | Percent relative intensity of each IS standard within 60 – 125%   |

**Table 3-7. Quality Control Samples (Field and Lab) for Metals in Soil and Water**

*Quality Assurance Project Plan, OU-2 Remedial Investigation 700 South 1600 East PCE Plume, Salt Lake City, Utah*

| QC Sample        | Frequency/ Number     | Method/SOP QC Acceptance Limits                                  | Corrective Action   | Person(s) Responsible for Corrective Action | Data Quality Indicator | Measurement Performance Criteria   |
|------------------|-----------------------|--|---|---|------------------------|--|
| Field Duplicates | One per 10 per matrix | RPD < 30% (aq), <50% (solid) for compounds w/ concentration > RL | Evaluate batch precision, other FD results<br>Note in validation report               | Data Validator                              | Precision              | RPD < 30% (aq), <50% (solid) for compounds w/ concentration > RL           |
| Equipment Blank  | Daily                 | Results < RL   | Evaluate sample results; flag data as necessary.<br>Review decontamination procedures | Data Validator                              | Accuracy               | Results < RL unless target analytes in field samples are > 10× those in EB |

<sup>a</sup> Internal standards are not required, but are optional for Method SW6010C. Empirical Laboratories does employ the use of internal standards for SW6010C.

Notes:

aq = aqueous

EB = equipment blank

FD = field duplicate

ICS = interference check sample

IS = internal standards

MDL = method detection limit

PDS = post digestion spike

QC = quality control

RL = reporting limit

RPD = relative percent difference

SOP = standard operating procedure

**Table 3-8. Precision and Accuracy for Metals in Soil and Water**

*Quality Assurance Project Plan, OU-2 Remedial Investigation 700 South 1600 East PCE Plume, Salt Lake City, Utah*

| Analyte   | Method        | Soil MS/MSD % Recovery | Soil LCS % Recovery | RPD <sup>a</sup> | Water MS/MSD % Recovery | Water LCS % Recovery | RPD <sup>a</sup> |
|-----------|---------------|------------------------|---------------------|------------------|-------------------------|----------------------|------------------|
| Aluminum  | SW6020A       | 75-125                 | 70-130              | 20               | 75-125                  | 70-130               | 20               |
| Antimony  | SW6020A       | 75-125                 | 50-150              | 20               | 75-125                  | 50-150               | 20               |
| Arsenic   | SW6020A       | 75-125                 | 70-130              | 20               | 75-125                  | 70-130               | 20               |
| Barium    | SW6020A       | 75-125                 | 70-130              | 20               | 75-125                  | 70-130               | 20               |
| Beryllium | SW6020A       | 75-125                 | 70-130              | 20               | 75-125                  | 70-130               | 20               |
| Cadmium   | SW6020A       | 75-125                 | 70-130              | 20               | 75-125                  | 70-130               | 20               |
| Calcium   | SW6020AS      | 75-125                 | 70-130              | 20               | 75-125                  | 70-130               | 20               |
| Chromium  | SW6020A       | 75-125                 | 70-130              | 20               | 75-125                  | 70-130               | 20               |
| Cobalt    | SW6020A       | 75-125                 | 70-130              | 20               | 75-125                  | 70-130               | 20               |
| Copper    | SW6020A       | 75-125                 | 70-130              | 20               | 75-125                  | 70-130               | 20               |
| Iron      | SW6020A       | 75-125                 | 70-130              | 20               | 75-125                  | 70-130               | 20               |
| Lead      | SW6020A       | 75-125                 | 70-130              | 20               | 75-125                  | 70-130               | 20               |
| Magnesium | SW6020A       | 75-125                 | 70-130              | 20               | 75-125                  | 70-130               | 20               |
| Manganese | SW6020A       | 75-125                 | 70-130              | 20               | 75-125                  | 70-130               | 20               |
| Mercury   | SW7470A/7471A | 75-125                 | 70-130              | 20               | 75-125                  | 70-130               | 20               |
| Nickel    | SW6020A       | 75-125                 | 70-130              | 20               | 75-125                  | 70-130               | 20               |
| Potassium | SW6020A       | 75-125                 | 70-130              | 20               | 75-125                  | 70-130               | 20               |
| Selenium  | SW6020A       | 75-125                 | 70-130              | 20               | 75-125                  | 70-130               | 20               |
| Silver    | SW6020A       | 75-125                 | 50-150              | 20               | 75-125                  | 50-150               | 20               |
| Sodium    | SW6020A       | 75-125                 | 70-130              | 20               | 75-125                  | 70-130               | 20               |
| Thallium  | SW6020A       | 75-125                 | 70-130              | 20               | 75-125                  | 70-130               | 20               |
| Vanadium  | SW6020A       | 75-125                 | 70-130              | 20               | 75-125                  | 70-130               | 20               |
| Zinc      | SW6020A       | 75-125                 | 70-130              | 20               | 75-125                  | 70-130               | 20               |

<sup>a</sup> RPDs are applicable to MS/MSD only

Notes:

LCS = laboratory control samples

MS/MSD = matrix spike/matrix spike duplicate

RPD = relative percent difference







**Table 3-11. Quality Control Samples (Field and Lab) for Volatile Organic Compounds in Soil Gas**

*Quality Assurance Project Plan, OU-2 Remedial Investigation 700 South 1600 East PCE Plume, Salt Lake City, Utah*

| QC Sample   | Frequency/<br>Number  | Method/SOP QC<br>Acceptance Limits   | Corrective Action                                   | Person(s)<br>Responsible for<br>Corrective<br>Action | Data Quality<br>Indicator   | Measurement Performance<br>Criteria  |
|---|-----------------------|--|---|--|-----------------------------|--|
| Method Blank  | Daily                 | Target analytes: < 50% RL;<br>common contaminants<br><2.5× RL  | Rerun, maintenance. Flag data                       | Laboratory<br>Chemist                                | Accuracy –<br>Contamination | Target Analytes < 50% RL;<br>common contaminants < 2.5×<br>RL unless results in field<br>samples > 10× that in method<br>blank   |
| LCS/LCS<br>Duplicate  | Daily                 | % Recovery = 70-130% RPD<br>< 30%  | Rerun, investigate source of<br>problems. Flag data | Laboratory<br>Chemist                                | Accuracy<br>Precision       | % Recovery 70-130% RPD<br><30%   |
| Field duplicate   | One per 10<br>samples | RPD < 40%  | Flag data   | Data Validator                                       | Precision                   | RPD <40%   |
| Internal<br>Standards   | Every sample          | Area ±40% DCV  | Rerun, flag data                                    | Laboratory<br>Chemist                                | Accuracy                    | Area ±40% DCV  |
| Surrogate spike   | Every sample          | % Recovery 70-130% or as<br>per lab limits   | Rerun, flag data                                    | Laboratory<br>Chemist                                | Accuracy                    | % Recovery 70-130% or as per<br>laboratory limits  |
| Reporting Limit<br>LCS  | Daily                 | Results ±40% true for 90%<br>of compounds  | Flag data that fall outside<br>control limits       | Laboratory<br>Chemist                                | Sensitivity                 | Results ±40% true for 90% of<br>compounds  |
| Cleaning<br>Procedure<br>verification<br>(SUMMA<br>canisters) | Each canister         | After cleaning, pressurized<br>canister (using zero humid<br>air) should not contain<br>Target Analytes greater<br>than 0.2 ppbV | Reclean the canister; perform<br>verification       | Laboratory<br>Chemist                                | Accuracy –<br>Contamination | After cleaning, pressurized<br>canister (using zero humid air)<br>should not contain Target<br>Analytes greater than<br>0.2 ppbV |

Notes:

DCV = daily calibration verification  
 LCS = laboratory control sample  
 ppbV = part(s) per billion by volume  
 QC = quality control  
 RL = reporting limit  
 RPD = relative percent difference  
 SOP = standard operating procedure

**Table 3-12. Quality Control Samples (Field and Lab) for General Chemistry Parameters in Water**

*Quality Assurance Project Plan, OU-2 Remedial Investigation 700 South 1600 East PCE Plume, Salt Lake City, Utah*

| QC Sample:                             | Frequency/ Number   | Method/SOP QC Acceptance Limits   | Corrective Action  | Person(s) Responsible for Corrective Action | Data Quality Indicator | Measurement Performance Criteria   |
|--|---|---|--|---|------------------------|--|
| Preparation Blank <sup>a</sup>         | One per prep batch of 20 or fewer samples of similar matrix | Target analytes < 50% RL; common contaminants < RL                        | Re-prepare and re-analyze, if sample concentration is >10× blank concentration narrate | Laboratory Supervisor                       | Accuracy               | Target analytes < 50% RL, common contaminants < RL; unless target analytes in field samples are > 10× those in method blank. |
| Laboratory Control Sample <sup>b</sup> | One per prep batch of 20 or fewer samples of similar matrix | Recovery within laboratory statistical QC limits as defined in Table 3-13 | Re-prepare and re-analyze, if recovery is high and sample is < RL narrate              | Laboratory Supervisor                       | Accuracy               | Recovery within laboratory statistical QC limits as defined in Table 3-13  |
| Laboratory Duplicate                   | One per prep batch of 20 or fewer samples of similar matrix | RPD ≤ 20% if sample concentration > 5×RL; ± RL if <5×RL                   | Check instrument performance, qualify data   | Laboratory Supervisor / Data Validator      | Precision              | Values ≥5×RL: RPD ±20%<br>Values < 5×RL: ±5× RL  |
| Matrix Spike Sample <sup>c</sup>       | One per prep batch of 20 or fewer samples of similar matrix | Recovery within laboratory statistical QC limits as defined in Table 3-13 | Re-prepare and re-analyze, if recovery is high and sample is < RL narrate              | Laboratory Supervisor / Data Validator      | Accuracy               | Recovery within laboratory statistical QC limits (< 4× spike value) as defined in Table 3-13                                 |
| Field Duplicates                       | One per 10 per matrix                                       | RPD <30% for compounds w/ concentration > RL                              | Evaluate batch precision, other FD results. Note in validation report                  | Data Validator                              | Precision              | RPD < 30% for compounds w/ concentration > RL  |
| Equipment Blank <sup>a</sup>           | Daily   | Results < RL  | Evaluate sample results; flag data as necessary. Review decontamination procedures     | Data Validator                              | Accuracy               | Results < RL unless target analytes in field samples are > 10× those in EB   |

<sup>a</sup> Not applicable to Method SM2540C (total dissolved solids) or Method SM2320B (alkalinity).

<sup>b</sup> Not applicable to Method SM2320B (alkalinity).

<sup>c</sup> Not applicable to Method SM2540C (total dissolved solids), Method RSK-175, or Method SM2320B (alkalinity)

Notes:

EB = equipment blank

FD = field duplicate

QC = quality control

RL = reporting limit

RPD = relative percent difference

SOP = standard operating procedure

**Table 3-13. Precision and Accuracy for General Chemistry Parameters in Water**

*Quality Assurance Project Plan, OU-2 Remedial Investigation 700 South 1600 East PCE Plume, Salt Lake City, Utah*

| Analyte         | Method                 | Water MS/MSD<br>% Recovery | Water LCS %<br>Recovery | RPD <sup>c</sup> |
|-----------------|------------------------|----------------------------|-------------------------|------------------|
| Chloride        | EPA 300.0 <sup>a</sup> | 87 – 111                   | 87 – 111                | 20               |
| Nitrate/Nitrite | EPA 300.0 <sup>a</sup> | 88 – 111                   | 88 – 111                | 20               |
| Nitrate/Nitrite | SM4500-NO3E            | 75 – 125                   | 80 – 120                | 20               |
| Sulfate         | EPA 300.0 <sup>a</sup> | 87 – 112                   | 87 – 112                | 20               |
| Sulfide         | SM4500S2-CF            | 80 – 120 <sup>b</sup>      | 80 – 120 <sup>b</sup>   | 20               |
| TOC             | SW9060                 | 80 – 120 <sup>b</sup>      | 80 – 120 <sup>b</sup>   | 20               |
| Alkalinity      | SM2320B                | 80 – 120 <sup>b</sup>      | 80 – 120 <sup>b</sup>   | 20               |
| TDS             | SM2540C                | NA                         | 80 – 120 <sup>b</sup>   | 20               |

<sup>a</sup> LCS and MS/MSD limits based on DoD QSM Version 5.1, Appendix C (DoD, 2017). For Method 300.0, used same limits as Method 9056.

<sup>b</sup> Laboratory limits.

<sup>c</sup> RPDs are applicable to MS/MSD only

Notes:

DoD = U.S. Department of Defense

LCS = laboratory control sample

MS/MSD = matrix spike/matrix spike duplicate

NA = Not applicable

RPD = relative percent difference

TDS = total dissolved solids

TOC = total organic carbon

**Table 3-14. Quality Control Samples (Field and Lab) for Stable Oxygen and Hydrogen Isotope Parameters in Water**  
*Quality Assurance Project Plan, OU-2 Remedial Investigation 700 South 1600 East PCE Plume, Salt Lake City, Utah*

| QC Sample:                      | Frequency/ Number                                     | Method/SOP QC Acceptance Limits   | Corrective Action   | Person(s) Responsible for Corrective Action | Data Quality Indicator | Measurement Performance Criteria   |
|---------------------------------|---|---|---|---|------------------------|--|
| PT Reference Water <sup>a</sup> | Run at the beginning of run and after every 8 samples | Not vary by more than 0.9‰ for δ2H and 0.12‰ for δ18O (1 standard deviation)  | If monthly values exceed the thresholds, the data from individual runs should be reviewed to identify and remedy potential errors in data processing or any systematic changes in instrument performance and their cause. | Laboratory Supervisor                       | Precision              | Not vary by more than 0.9‰ for δ2H and 0.12‰ for δ18O (1 standard deviation) |
| PZ Reference Water <sup>a</sup> | One per sample tray run                               | Standard deviation should be no more than 20% of the average parameter value across the month   | Review data from individual runs to identify and remedy potential error or systematic changes. Reanalyze sample and reassess if necessary   | Laboratory Supervisor                       | Precision              | Less than or equal to 20% average over the month                             |
| UT Reference Water <sup>a</sup> | One per sample tray run                               | Standard deviation should be no more than 20% of the average parameter value across the month   | Review data from individual runs to identify and remedy potential error or systematic changes. Reanalyze sample and reassess if necessary   | Laboratory Supervisor                       | Precision              | Less than or equal to 20% average over the month                             |
| Field Duplicates                | One per 10 per matrix                                 | Standard deviation of calibrated isotopic values for 3 or more replicate injections of the unknown sample must be less than 0.2‰ (δ18O) and 0.75‰ (δ2H) | Evaluate batch precision, other FD results. Note in validation report   | Data Validator                              | Precision              | RPD < 50% for compounds w/ concentration > RL                                |

<sup>a</sup> PT, PZ, and UT are internal reference materials developed by the Stable Isotopes Ratio Facility for Environmental Research, University of Utah for use as quality control standards to monitor method performance.

Notes:

FD = field duplicate

RPD = relative percent difference

QC = quality control

SOP = standard operating procedure

RL = reporting limit

## 3.6 Instrument/Equipment Testing, Inspection, Maintenance (B6) and Calibration (B7)

The following subsections discuss inspection, testing, and regularly scheduled preventive maintenance to keep all field and laboratory equipment in good working condition.

### 3.6.1 Field Equipment

Field personnel will record service and maintenance information of all field equipment in the project field logbook(s). Instrument problems encountered during field work will be remedied in the field, if possible, and documented in the field notes. Specific preventive maintenance procedures will follow the manufacturer's recommended schedule. Preventive maintenance will be the responsibility of the FTL. Field equipment that becomes inoperable will be removed from service and tagged to indicate that repair, recalibration, or replacement is needed. Field team leaders will be notified so that prompt service can be completed or substitute equipment can be obtained. Back-up systems will be prearranged for each instrument in use and will be calibrated before use in the field. The maintenance schedule is tracked internally by the FTL using a spreadsheet in conjunction with an Outlook calendar reminder via email.

Field equipment calibration is necessary so that measurements are accurate in reference to a known standard. Equipment will be calibrated according to the manufacturer's instructions, but at least daily, with more frequent calibration to correct drift or if the daily event indicates the instrument is not holding calibration. More complete information on field equipment calibration is discussed further in SOP 5-1, *Control of Measurement and Test Equipment* (Appendix A). A calibration will be verified at any time during the day when measurements are suspected to be erroneous. Calibration solutions will be available onsite with each instrument and will be renewed before the expiration dates stamped on the manufacturer's container. Documentation of each calibration will include the lot number and expiration of the calibration standards. Additional batteries will be maintained onsite. All calibration information will be recorded on daily field forms and in the project logbook. Calibration records for the equipment will be readily available for reference. In addition, the portable GC/MS (HAPSITE) will be calibrated daily in accordance with the manufacturer's operating instructions provided in the SOP (Appendix A).

Field equipment that fails calibration or becomes inoperable during use will be removed from service and either segregated to prevent inadvertent use or tagged to indicate it is out of calibration. Such equipment will be repaired and satisfactorily recalibrated. Equipment that cannot be repaired will be replaced.

Results of activities performed using equipment that has failed recalibration will be evaluated by the FTL and the project data manager. If the activity results are adversely affected, the results of the evaluation will be documented and the PM and (other data users) will be notified. The PM will take appropriate action, including the rejection of the data, if needed, with recollection of the data where practical, and will obtain concurrence from USACE/VHA for issues with field data that would impact results of the investigation.

### 3.6.2 Laboratory Equipment

The laboratories will follow a maintenance schedule for each instrument used to analyze samples as provided in the laboratory QA manual. Instrument maintenance logbooks are maintained in laboratories at all times. The logbooks, in general, contain a schedule of maintenance as well as a complete history of past maintenance, both routine and non-routine. Preventive maintenance is

1 performed according to the procedures described in the manufacturer's instrument manuals  
2 including lubrication, source cleaning, detector cleaning, and the frequency of such maintenance.  
3 Chromatographic carrier gas-purification traps, injector liners, and injector septa are cleaned or  
4 replaced on a regular basis. Precision and accuracy data are examined for trends and excursions  
5 beyond control limits to determine evidence of instrument malfunction. Maintenance will be  
6 performed when an instrument begins to degrade as evidenced by the degradation of peak  
7 resolution, shift in calibration curves, decrease in sensitivity, or failure to meet one QC criteria.

8 Instrument downtime is minimized by keeping adequate supplies of all expendable items, where  
9 expendable means an expected lifetime of less than 1 year. These items include gas tanks, gasoline  
10 filters, syringes, septa, gas chromatography columns and packing, ferrules, printer paper and  
11 ribbons, pump oil, jet separators, open-split interfaces, and mass spectroscopy filaments.

12 Analytical instruments will be calibrated in accordance with the method specified by the  
13 laboratory. All analytes reported must be present in the initial and continuing calibrations, and  
14 these calibrations must meet the acceptance criteria specified in the method. The laboratory will  
15 maintain records of standard preparation and instrument calibration. Records will unambiguously  
16 trace the preparation of standards and their use in calibration and quantitation of sample results.  
17 Calibration standards will be traceable to standard materials.

18 Initial calibration (ICAL) curves must be verified using a standard from a source independent of the  
19 one used to establish the ICAL standards. All target compounds must be included within the initial  
20 calibration verification, typically at a concentration around the midpoint of the calibration curve.  
21 Failure of the initial calibration verification requires corrective action.

22 The ICAL curves must be verified daily before sample analysis using a continuing calibration  
23 verification (CCV). The CCVs are required check samples at the beginning of each analytical  
24 sequence and as specified in each analytical method. All target compounds must be included within  
25 the CCV, typically at a concentration around the midpoint of the calibration curve. Failure of the  
26 ICAL or CCV requires corrective action.

27 Standard materials used in calibration and to prepare samples will be traceable to the National  
28 Institute of Standards and Technology, EPA, the American Association of Laboratory Accreditation,  
29 or other approved sources if available. The standard materials will be current; the expiration dates  
30 for standards will not exceed the manufacturer's expiration date or 1 year from the date of receipt,  
31 whichever occurs first. Expiration dates for laboratory-prepared stock and diluted standards will  
32 be no later than the expiration date of the stock solution or material, or the date calculated from the  
33 holding time allowed by the applicable analytical method, whichever occurs first. The laboratory  
34 will label standard and QC materials with expiration dates.

### 35 **3.7 Inspection/Acceptance of Supplies and Consumables (B8)**

36 The FTL will obtain and verify all supplies and consumables are on hand when needed and have  
37 been inspected and tested for suitability of use. Most supplies and consumables to be used in the  
38 field will be procured from an environmental sampling supply vendor. Before any item is used in  
39 the field, it will be inspected and tested. Any defective material will be replaced before the  
40 sampling event begins. All sample containers, with appropriate preservation, will be procured from  
41 a commercial provider. Containers may be supplied by the laboratories; however, the laboratory  
42 will also purchase containers from a commercial provider. All containers must be certified clean  
43 including SUMMA canisters, which will be individually certified. All containers and coolers will be

1 inspected before they are used for collecting and shipping samples. Appropriate materials,  
2 including bubble wrap, plastic bags, tape, and supplies, will be available for packing samples to  
3 avoid breakage during transportation.

4 Supplies and consumables for field instrumentation to be used during the investigation of OU-2 will  
5 be consistent with the corresponding operating manual for the device. SOPs for the operation of  
6 field devices and equipment to be used during the investigation can be found in Appendix A.

### 7 **3.8 Data Acquisition Requirements (Non-direct Measurements** 8 **– B9)**

9 Non-direct measurements including historical data (for example, water quality data and,  
10 groundwater elevation measurements) were used in the development of the conceptual site model  
11 and the OU-2 project objectives. Relevant historical data will be stored in a project-specific  
12 database built in the EarthSoft EQUIS system described in the data management plan (CH2M, 2017).  
13 All manually generated information (for example, field test results and GIS sample coordinates) will  
14 undergo QC verification as required by the project data manager. The acceptance criteria for  
15 existing data are included in relevant SOPs (Appendix A), as applicable. If specific criteria are not  
16 available, professional judgment will be applied. Data that may not or do not meet current DQO will  
17 be excluded from use or qualified for use in the document where those data are used or reported.  
18 In the case of the Groundwater Flow Model and Solute Transport Model, the acceptance criteria and  
19 any limitations on use of data will be documented in the Groundwater Model QAPP. Computer  
20 programs generating or maintaining electronic information will be verified by the developer or  
21 manufacturer before implementation. All computer systems will have a minimum security of  
22 password protection. All project information will be considered confidential and only project  
23 personnel will be allowed access.

### 24 **3.9 Data Management (B10)**

25 Data management includes information recording or transcription; data reduction and  
26 manipulation for evaluation, review, approval, and reporting; and the process of document  
27 tracking, storage, and retrieval of all information obtained during sample collection and analysis.  
28 The project data manager will oversee the data handling and management processes for all forms of  
29 data collected. The project team will provide the processes and guidelines for sample tracking,  
30 storage, access, delivery, and reporting of new chemical analytical, geologic, and spatial data  
31 generated by investigation operations. Key data management objectives include the following:

- 32 ■ Apply well-documented data validation modifications to the electronic data
- 33 ■ Manage sample data using a unique sample identification number that conforms to the  
34 sample labeling specified in Section 5.11.2 of the FSP (Appendix A-1 of the RIWP [CH2M,  
35 2018])
- 36 ■ Establish a sample inventory of data collected and provide methods of sample inventory  
37 reconciliation
- 38 ■ Store and provide sample-specific attributes, including location identifier, sample type,  
39 sample media, depth, date, and target study area in a manner compatible with ArcGIS format

- 1     ■ Provide reporting and delivery formats to support data analysis, site characterization, risk  
2     assessment, modeling, and spatial analysis
- 3     ■ Review laboratory data and verification are performed by a qualified laboratory analyst at  
4     the contracted laboratory before releasing data electronically to the consultant

5     Field personnel will record all raw field data and measurements into an appropriate format for  
6     reporting purposes. The records of all data reduction calculations must be kept on the project-  
7     specific field forms or field logbook. Data recorded on equipment memory or removable memory  
8     cards such as photographs or GIS data will be downloaded at the end of the work day onto a laptop  
9     computer, and then uploaded to the CDM Smith server to create a backup of the electronic field  
10    data. The FTLs will verify the field personnel appropriately and correctly enter field data into the  
11    project-specific field forms and field logbooks as well as internal project database, which is  
12    compatible with ArcGIS.

13    All data entered into any database system will be verified by the FTL or their designee by printing a  
14    hard copy of all field information entered (for example, water level, purge volume, and field water-  
15    quality constituents, and portable GC/MS measurements) and comparing against raw data values  
16    contained on the field form.

17    The laboratory analyst will convert all raw values produced in the laboratory into reportable  
18    values. The records of all data reduction calculations must be kept on the appropriate laboratory  
19    worksheet. If the final values are not generated by direct-reading instruments or if a computer  
20    analyst performs all necessary data reduction of the raw data, the laboratory analyst will record the  
21    final values on computer-generated laboratory worksheets. All strip charts and chromatograms  
22    must be labeled, dated, and initialed by the analyst performing the analysis. Each laboratory  
23    worksheet bears a unique run-ID number. This run-ID number is part of a multiple index system  
24    used by the laboratory information management system (LIMS) to identify the samples and  
25    constituents performed for an individual worksheet. The analyst will also verify that reagent  
26    spikes, blanks, check standards, and duplicates are within acceptable limits. If all QC samples are  
27    within acceptable limits, the analyst will submit the worksheets for processing into the LIMS. The  
28    LIMS stores the data until all requested analyses are complete; the data are then transferred to the  
29    final electronic deliverable (EQuIS EDD file formats) for transmittal to CDM Smith. An electronic  
30    deliverable will be provided by the contracted laboratory in a Microsoft Excel format following the  
31    guidelines/example for EQuIS at [earthsoft.com/support/edd-formats/EQEDD](http://earthsoft.com/support/edd-formats/EQEDD). All laboratory EDDs  
32    will be uploaded into the EQuIS database system for maintaining, reporting, and archiving.

33    On receipt, all field data are printed and checked for anomalies by the project data manager and  
34    QA/QC manager. The project data manager and QA/QC manager will also review the laboratory  
35    data to identify any anomalies requiring follow-up with field team members or the laboratory.

36    All test runs (standards, blanks, and samples) made on the field portable GC/MS are stored in  
37    digital form on internal memory cards. The test runs are identified by type (such as standard,  
38    blank, sample, and duplicate), matrix (such as soil, water, soil gas, and indoor air), sample name,  
39    date, time, injection volume, and analysis number (sequential number assigned daily by the  
40    GC/MS). At the conclusion of each day, data will be transferred from the GC/MS to a personal  
41    computer for backup, and a hard copy of each analysis will be printed for retention in a backup file.



1 The CDM Smith team will retain the entire project file as hard copy and/or electronic data on CDM  
2 Smith project servers until the completion of all project activities. Thereafter, all data will be  
3 provided to USACE/VHA and archived by CDM Smith in a secure and protected facility and  
4 maintained for a minimum of 3 years after contract closeout, per FAR 52.215-2 (Audit and  
5 Records). Analytical results and sample location data collected during the RI will be entered into a  
6 GIS database for mapping and publication, and the GIS metadata and files will be provided to  
7 USACE/VHA and archived by CDM Smith in electronic format for transmittal to EPA and UDEQ,  
8 if requested.

9 The official administrative record file for the site (hardcopy records) is located at the Salt Lake City  
10 Public Library – Anderson-Foothill Branch, in Salt Lake City, Utah. Compact disc copies of project  
11 reports, including the RIWP, sampling analysis plan, and QAPP will also be provided to EPA and  
12 UDEQ. A copy of the administrative record file is also located at the VHA Salt Lake City Health Care  
13 System 500 Foothill Drive in Salt Lake City, Utah 84148. EPA Region 8 in Denver, Colorado, and  
14 UDEQ in Salt Lake City, Utah, will receive all copies of documents, laboratory data, and other  
15 published project information for their records.



# 1 Section 4

## 2 Assessment and Oversight (EPA Group C)

3 This section addresses the activities required to properly assess the effectiveness of the project  
4 implementation and the associated QA/QC activities. It includes the following:

- 5 ■ Assessment and Response Action (C1)
- 6 ■ Reports to Management (C2)

### 7 4.1 Assessments and Response Actions (C1)

8 This subsection presents activities for assessing the effectiveness of QAPP implementation, which  
9 includes audits and corrective action.

#### 10 4.1.1 Laboratory Audits

11 Prior to receiving samples, an onsite technical system audit (TSA) of each laboratory will be  
12 performed, as needed, with the exception of the stable isotope and geotechnical laboratories. TSAs  
13 are the most frequently performed type of audit and consist of a project-specific onsite evaluation  
14 of a measurement or data collection system. TSAs for project activities are performed to verify that  
15 requirements (that is, procedural, regulatory, or contractual) are being met. EPA and UDEQ will be  
16 notified when a TSA is to be performed. The objective of a TSA is to assess all system facilities and  
17 to document system operations and maintenance, experimental procedures, recordkeeping,  
18 calibration procedures, reporting requirements, data validation, and QC procedures. Each item is  
19 defined in the approved QAPP, which provides the basis for the TSA. Any undocumented or  
20 unauthorized deviations from the QAPP and corrective action are noted in the written laboratory  
21 audit report. A TSA report will be developed, which will include any necessary corrective actions  
22 for the laboratory.

#### 23 4.1.2 Corrective Action Procedures

24 Conditions adverse to data quality must be promptly investigated, evaluated, and corrected.  
25 Adverse conditions may include instrument malfunctions, deficiencies in QA/QC criteria, deviations  
26 from SOPs, and errors in data reduction, validation, or documentation.

##### 27 4.1.2.1 Field Corrective Action Procedures

28 All CDM Smith project personnel, subcontractors, consultants, VHA, and USACE project personnel  
29 will be responsible for identifying project deficiencies and notifying the QAM. Any defects and  
30 deficiencies identified will be documented in the daily report and added to a tracking system (for  
31 example, electronic spreadsheet). The QC officer will describe any deficient items and the change in  
32 status of any deficiencies in the daily report and in a non-conformance report. USACE and VHA will  
33 be notified of all identified deficiencies, the prescribed corrective actions, and the status of the  
34 corrective action through completion. The information will be provided to USACE and VHA in the  
35 daily report and during coordination meetings.

36 The effective implementation of the QAPP in the field will be evaluated through a system audit  
37 during the field phase of the investigation. The field system audit will assess compliance with the  
38 FSP/QAPP procedures and SOPs for field investigation including, but not limited to, recordkeeping,

1 equipment calibration, sampling procedures, decontamination, and field data verification. EPA and  
2 UDEQ will be notified when a field audit is to be performed. System audits will be conducted by an  
3 individual not working directly on the project. The FTL will verify that the following corrective  
4 actions for non-conformances are implemented:

- 5     ▪ Evaluate all reported non-conformances
- 6     ▪ Control additional work on non-conforming items
- 7     ▪ Determine disposition or action to be taken
- 8     ▪ Verify that corrective actions were taken
- 9     ▪ Maintain a log of non-conformances
- 10    ▪ Review non-conformance reports
- 11    ▪ Evaluate disposition or action taken
- 12    ▪ Monitor inclusion of non-conformance reports in final site documentation and document  
13      control
- 14    ▪ Notify the PM, who will notify USACE of non-conformances and corrective actions. USACE  
15      will then notify VHA.

16 The FTL will guarantee that no additional work dependent on the non-conforming activity is  
17 performed until the non-conformance is corrected. Also, the FTL will implement corrective action  
18 as initiated by the QAM. Each non-conformance report will be evaluated, and the disposition and  
19 action taken will be recorded.

20 For any issued deliverable or document, all staff will be responsible for reporting all suspected QA  
21 nonconformance by initiating a preventive/corrective action notification.

#### 22 **4.1.2.2      Laboratory Corrective Action Procedures**

23 The laboratory QA plan defines the laboratory internal corrective action process and requirements.  
24 When a condition adverse to data quality is noted at the laboratory, the cause of the condition will  
25 be determined and corrective action will be taken to re-establish control. Identification, cause,  
26 reference documents, corrective action taken, and effectiveness will be documented and reported  
27 to the PM by the laboratory QC officer. Implementation of corrective action is verified by  
28 documented follow-up action. A record of the action taken and results will be attached to the data  
29 report package.

30 Project personnel have the responsibility, as part of normal work duties, to identify, report, and  
31 solicit approval of corrective actions for conditions adverse to data quality. Examples of corrective  
32 actions include, but are not limited to, the following instances:

- 33     ▪ When project-specific acceptance criteria are not attained (objectives for precision, accuracy,  
34       and completeness)
- 35     ▪ When the prescribed procedure or any data compiled contains an error
- 36     ▪ When equipment or instrumentation is determined to be faulty

- 1     ▪ When the traceability of samples, standards, or analytical results is questionable
- 2     ▪ When QA requirements have been violated
- 3     ▪ When designated approvals have been circumvented
- 4     ▪ As a result of systems or performance audits
- 5     ▪ As a result of regular management assessments
- 6     ▪ As a result of intra-laboratory or inter-laboratory comparison studies
- 7     ▪ Any other instance of conditions that adversely affect quality

8 Analysts conducting sample analysis activities may take immediate corrective action for out-of-  
9 control conditions. Faulty calibrations and blank contamination are examples of out-of-control  
10 conditions. Immediate corrective and successful action will reduce questionable data quality.  
11 Corrective actions for these types of failures should be documented in an instrument logbook,  
12 which will be available for the final data report.

13 Laboratory staff will monitor work performance in the normal course of daily responsibilities. The  
14 laboratory QA manager or designated alternate will audit work at the laboratory. Items, activities,  
15 or documents ascertained to be non-compliant with QA requirements will be documented, and  
16 corrective actions will be mandated in the audit report. The laboratory QA manager will log,  
17 maintain, and control the audit findings.

18 The laboratory QA manager will document all out-of-control events or non-conformance with QA  
19 protocols. The report will summarize each non-conformance condition. A copy of the reports will  
20 be submitted with the final data package. The QA/QC manager in consultation with the program  
21 manager may initiate a stop-work order if corrective actions are insufficient.

## 22 4.2 Reports to Management (C2)

23 This subsection describes how management (USACE, VHA, EPA, and UDEQ) will be kept informed of  
24 project oversight and assessment activities and findings. It describes what kinds of reports will be  
25 written and how often they will be submitted for review to the approving authorities.

### 26 4.2.1 Report Type and Frequency

27 Project reports submitted during the course of the project will include, but may not be limited to,  
28 the following submittals in accordance with the project schedule and key investigation events:

- 29     ▪ **Progress Reports** – Communicate the progress made on a monthly basis regarding site  
30 investigation, community involvement, achievement of project milestones, and the myriad of  
31 actions that encompass the investigation of OU-2. These reports will be written by the PM or  
32 designee and submitted to USACE and VHA.
- 33     ▪ **Data Summary Reports** – Communicate the conclusions of individual investigation events  
34 for OU-2 and any laboratory analysis associated with the event. These reports will be written  
35 by the PM or designee and submitted to USACE and VHA.
- 36     ▪ **Data Validation and Usability Reports** – Summarize the number and types of samples  
37 collected, including field QC samples, analytical methods performed, and data evaluation

1 purpose. Provide a summary of the overall completeness of the data set and discuss any  
2 limitations in the use of the analytical data. Refer to Section 5.3.1 for additional details.

- 3 ■ **Nonconformance Reports** – Identify any deviations of planned or expected scope-of-work  
4 activities relating to the investigation of OU-2. Reports may pertain to field data collection  
5 and health and safety events. These reports will be written by the PM or QAM and submitted  
6 to USACE and VHA.
- 7 ■ **Laboratory Audit Reports/Corrective Action Reports** – Communicate the result of any  
8 third-party audit or review of the analytical laboratory supporting the investigation activities.  
9 This report will be written by the project chemist. The reports will be submitted to the PM,  
10 USACE, and VHA.
- 11 ■ **Remedial Project Manager Meetings** – Conduct quarterly conference calls among USACE,  
12 VHA, EPA, UDEQ and other key stakeholders to discuss current planning and investigation.
- 13 ■ **Interim RI Report** – Summarize field data collection efforts for OU-2 and include field forms,  
14 validated analytical data, groundwater modeling calibration results, and recommendations  
15 for additional investigation activities.
- 16 ■ **RI Report** – Communicate the conclusions of all investigation events for OU-2 and any  
17 laboratory analysis associated with the event. This report will also contain data validation  
18 reports and deviations from the FSP and QAPP. The RI report will incorporate data and  
19 information from the previous and current investigations into a comprehensive document.  
20 The report format will closely follow the EPA/540/G-89/004-OSWER Directive 9355.3-01  
21 *Guidance for Conducting Remedial Investigations and Feasibility Studies under the*  
22 *Comprehensive Environmental Response Compensation and Liability Act (CERCLA (EPA, 1988)*  
23 *and will include historical and background information, field measurements, analytical*  
24 *results, a summary of field protocols, identified vertical and horizontal extent of*  
25 *contamination, geologic data interpretations, and ecological and baseline risk assessment*  
26 *results. CDM Smith will prepare a preliminary draft report, responses to VHA comments on*  
27 *the preliminary draft report, a draft report, responses to stakeholder comments, and a final*  
28 *report incorporating all review comments and documenting the results and findings of the RI.*  
29 *This report will be written and submitted by CDM Smith to USACE and VHA, with distribution*  
30 *by VHA to EPA and UDEQ Remedial Project Managers.*

31 Table 4-1 provides a summary of the above reports and communications and identifies the  
32 responsible author, reporting frequency, and the recipient(s) of the deliverable.

**Table 4-1. Summary of Reports to Management***Quality Assurance Project Plan, OU-2 Remedial Investigation 700 South 1600 East PCE Plume, Salt Lake City, Utah*

| <b>Reports</b>   | <b>Frequency</b>                              | <b>Provided to</b>  | <b>Format</b>        | <b>Prepared by</b>          |
|--|---|---|----------------------|-----------------------------|
| Progress reports   | Monthly                                       | USACE   | Written              | PM                          |
| Site investigation reports, field summary reports (that is, data summary reports), data validation and usability reports, interim RI Report, and RI Report | As needed                                     | USACE and VHA, with distribution by VHA to EPA and UDEQ           | Written              | CDM Smith                   |
| Field change requests to document deviations from the QAPP   | As needed                                     | USACE and VHA, with distribution as needed by VHA to EPA and UDEQ | Written              | CDM Smith                   |
| Nonconformance reports   | As needed                                     | USACE and VHA, with distribution as needed by VHA to EPA and UDEQ | Written              | PM, QAM                     |
| Laboratory audit (TSA)/CARs  | As scheduled                                  | USACE and VHA, with distribution by VHA as needed to EPA and UDEQ | Written              | Project chemist or designee |
| Field (QAPP) implementation audit / CARs   | As scheduled, at least once during field work | USACE and VHA, with distribution by VHA as needed to EPA and UDEQ | Written              | QAM                         |
| Remedial Project Manager Meetings  | Quarterly                                     | USACE and VHA, with distribution by VHA to EPA and UDEQ           | Verbal, with minutes | CDM Smith                   |

**Notes:**

CAR = corrective action report

EPA = U.S. Environmental Protection Agency

PM = project manager

QAPP = quality assurance project plan

QAM = quality assurance manager

RI = remedial investigation

TSA = technical system audit

UDEQ = Utah Department of Environmental Quality

USACE = U.S. Army Corps of Engineers

VHA = Veterans Health Administration





# 1 Section 5

## 2 Data Validation and Usability (EPA Group D)

3 This section addresses QA activities that will occur after the data collection phase is completed,  
4 which include the following:

- 5 ■ Data Review, Verification and Validation (D1)
- 6 ■ Verification and Validation Methods (D2)
- 7 ■ Reconciliation with User Requirements (D3)

### 8 5.1 Data Review, Verification, and Validation (D1)

9 Data for all parameters will undergo two levels of review and validation, one at the laboratory and  
10 another by the QA/QC manager, or designee, to include third-party reviewers. Verification of data  
11 generated from field activities will also be performed.

#### 12 5.1.1 Field Data Verification

13 Field personnel will be responsible for following the sampling and documentation procedures  
14 described in Section 3 and Section 5 of the FSP (Appendix A-1 of the RIWP [CH2M, 2018]) so that  
15 defensible and justifiable data are obtained. Integrity of information and field activity data will be  
16 the responsibility of the FTL. Project team personnel will validate field data through reviews to  
17 identify inconsistencies or anomalous values.

18 All information generated in the field (all data, calibration, logbook, field data sheets, chain-of-  
19 custody records, inspection reports, drilling logs, and non-conformity reports) will be assembled  
20 for review and will be verified by a peer review process. Example field forms are provided in  
21 Appendix A of the FSP (Appendix A-1 of the RIWP [CH2M, 2018]). A sample chain-of-custody form  
22 is included in Appendix B. If possible, any inconsistencies discovered will be resolved immediately  
23 by seeking clarification from the field personnel responsible for data collection. Integrity of the  
24 field sample custody is accomplished according to the sample custody procedures previously  
25 defined in Section 3.3. The field documentation verification process is summarized in Table 5-1.

#### 26 5.1.2 Laboratory Data Reduction, Review, and Approval

27 The laboratory review of Contract Laboratory Program equivalent data is a four-step process  
28 involving an evaluation by the analyst, a peer review, an administrative review, and a QA review.  
29 The review will include but is not limited to the following:

- 30 ■ Instrument calibrations
- 31 ■ Raw data
- 32 ■ Transcribed data
- 33 ■ Calculations including calculations of precision, accuracy, representativeness, completeness,  
34 comparability, and sensitivity

1 The analyst will review all laboratory data before reporting. The establishment of detection and  
2 control limits will be verified. Any data outside of the established detection or control limits  
3 specified in the analytical methods will be identified. Any trends or problems with the data will be  
4 evaluated. The absence of records supporting the establishment of control criteria or detection  
5 limits will be noted. Analytical batch QC, calibration check samples, initial calibrations, continuing  
6 calibration verifications, corrective action reports, results of re-analysis, sample holding times, and  
7 sample preservations will be evaluated.

8

**Table 5-1. Data Verification Processes for Field and Lab Results**

*Quality Assurance Project Plan, OU-2 Remedial Investigation 700 South 1600 East PCE Plume, Salt Lake City, Utah*

| <b>Verification Input</b>   | <b>Description</b>   | <b>Internal/<br/>External (I/E)</b> | <b>Responsible for Verification<br/>(Name, Organization)</b> |
|---|--|-------------------------------------|--|
| Field logbook   | All entries complete, signed, corrections properly initialed, sample list corresponds to chain of custody  | I                                   | FTL  |
| Chain-of-custody forms  | Field chain of custody is completed with legible sample ID, dates, times, all analytical parameters correctly entered, preservatives noted, signatures<br>Laboratory chain of custody indicates any errors, signatures signifying acceptance of custody  | I                                   | FTL  |
|   |  | E                                   | Laboratory sample custodian                                  |
| Sample location data (GPS coordinates)                            | All sample locations have associated northings, eastings, elevation  | I                                   | FTL  |
| Field originated NCRs/CARs  | When required, properly completed with appropriate corrective action specifics and signatures where required; properly filed   | I                                   | QAM  |
| Field summary reports   | Submitted on weekly basis, properly archived on server, each day of work week accounted for, all information present   | I                                   | PM   |
| Field surveillance (TSA) report                                   | Report details date of surveillance, person(s) conducting, findings and observations recorded, NCR/CAR as needed, follow-up response documented  | I                                   | QAM  |
| Sample receiving document   | Laboratory verified against chain of custody   | E                                   | Laboratory sample custodian                                  |
| Draft laboratory results  | All samples have results as requested, IDs match chain of custody, all QC present and reported as per QAPP   | E                                   | Laboratory QA manager or designee                            |
| Laboratory surveillance report                                    | Report details date of surveillance, person(s) conducting, findings and observations recorded, NCR/CAR as needed, follow-up response documented  | I                                   | QAM designee   |
| Analytical data package   | Verify data package for completeness including the presence of laboratory case narrative, sample receipt form, holding times record. Sample results, blank results, MS/MSD summary forms, LCS summary forms. Surrogate and internal summary forms (where appropriate), initial and continuing calibration summary and raw data | I                                   | Project chemist during data validation stage                 |
|   |  | E                                   | Lab QA manager designee                                      |
| Laboratory originated NCRs/CARs                                   | When required, properly completed with appropriate corrective action specifics and signatures; properly filed  | E                                   | Lab QA manager or lab PM                                     |
| Field change request to document QAPP modifications or deviations | Verify that all QAPP modifications are documented  | I                                   | QAM  |
| Analytical EDDs   | Verify that all SDGs are reported in specified format and have required deliverables   | E                                   | Lab QA/QC Manager or lab PM                                  |

Notes:

CAR = corrective action report  
 EDD = electronic data deliverable  
 FTL = field team leader  
 GPS = geographic positioning system  
 ID = identification

LCS = laboratory control samples  
 MS/MSD = matrix spike/matrix spike duplicate  
 NCR = non-conforming report  
 PM = project manager  
 QA = quality assurance

QAPP = quality assurance project plan  
 QC = quality control  
 QAM = quality assurance manager  
 SDG = sample delivery group  
 TSA = technical system audit

- 1 Samples associated with out-of-control QC data will be identified in the data package case narrative.  
 2 An assessment of the utility of such analytical results will be made. Table 5-2 provides the common  
 3 data qualifiers that should be used to identify specific data limitations.

**Table 5-2. Laboratory Data Validation Qualifiers**

*Quality Assurance Project Plan, OU-2 Remedial Investigation 700 South 1600 East PCE Plume, Salt Lake City, Utah*

| Qualifier | Explanation of Qualifier   |
|-----------|--|
| U         | The compound was analyzed for, but was not detected above, the reported method detection limit.  |
| J         | The analyte was positively identified. The associated numerical value is the approximate concentration of the analyte in the sample, or the reported concentration is greater than the instrument detection limit, but less than the quality assurance project plan specified reporting limit. |
| R         | The sample results are rejected due to serious deficiencies in the ability to analyze the sample and meet quality control criteria. The presence or absence of the analyte cannot be verified.   |
| UJ        | The analyte was not detected above the reported method detection limit. However, the reported limit is approximate and may or may not represent the actual limit of quantitation necessary to accurately and precisely measure the analyte in the sample.                                      |

4 The review of laboratory data completeness will be documented to confirm the following activities:

- 5     ■ All samples and analyses specified on the chain-of-custody record were analyzed and  
6       reported
- 7     ■ Complete records exist for each analysis and the associated QC samples
- 8     ■ Procedures specified in this QAPP were implemented

9 An analyst other than the original data processor will perform a peer review of all steps of the data  
 10 processing. One hundred percent of all data will be reviewed. All input parameters, calibrations,  
 11 and transcriptions will be checked. Each page of checked data will be signed and dated by the  
 12 verifier.

13 QC sample results are compared against stated criteria for accuracy and precision. QC data must  
 14 meet acceptance levels before processing the analytical data. If QC standards are not satisfactory,  
 15 the cause will be determined. If the cause can be corrected without affecting the integrity of the  
 16 analytical data, data processing will proceed. If a resolution jeopardizes the integrity of the data,  
 17 reanalysis will ensue.

18 The laboratory PM will perform an administrative review on each data deliverable package. The  
 19 review will determine if requirements of the laboratory and the data deliverable have been met and  
 20 are complete.

21 A review of approximately 10 percent of all data deliverable packages from a laboratory QA  
 22 manager must occur before the administrative review and final release of the data deliverable to  
 23 verify that all QC requirements of the project and analytical methods have been met. The data  
 24 packages will be randomly selected for review.

25 Each step of this review process involves evaluating data quality based on both the results of the QC  
 26 data and the professional judgment of those conducting the review. This application of technical  
 27 knowledge and experience is essential to provide data of consistently high quality.

## 5.2 Verification and Validation Methods (D2)

Data validation and verification generated during field and laboratory activities are essential to obtaining data of defensible and acceptable quality. Data to be used in evaluating project technical objectives must be assessed to determine whether the data are of sufficient quality to allow their unrestricted use. It is the joint responsibility of VHA and CDM Smith to verify that the data collected meet the requirements specified in Section 3.

The *Guidance for Evaluating Performance Based Chemical Data* (PB review) (USACE, 2005) and the EPA Contract Laboratory Program National Function Guidelines (NFGs) for data validation have been used to develop the data validation specifications for this QAPP. The USACE PB review guidance specifically states; “The data review protocols presented in this document should not be viewed as prescriptive algorithms but as strategies intended for the purposes of guidance.” The NFGs have not and cannot be applied prescriptively, as the purpose of the NFGs were to “aid the data viewer in determining the usability of analytical data generated using the United States Environmental Protection Agency (EPA) Contract Laboratory Program (CLP) Statement of Work (SOW)” [EPA, 2017a, 2017b]. The methods employed for this RI are beyond the scope of the CLP methods, and no CLP methods are being used. Instead, both the PB review and NFG documents have been used as guide to develop the data validation guidance for the methods utilized as specified in the paragraphs below and in Section 5.3. Every method and their associated quality control indicators have been addressed by the QAPP validation specifications. The data validation specifications provided in the QAPP are designed to produce defensible data of acceptable quality for all QAPP methods.

After sampling is complete and the laboratory has submitted the final data package, CDM Smith will conduct data validation using the calibration and QC requirements specified in Section 3 for those specified in the guidelines. Data validation will not be performed on the geotechnical sample analyses. A summary of the validation procedure is provided in Table 5-3 and the data validation flagging criteria is specified in Tables 5-4 and 5-5. Ninety percent of all samples will receive a (EPA Stage 2B) validation review (EPA, 2009), and 10 percent of the samples for each analysis performed will receive a (EPA Stage 4) validation review.

Laboratory data validation will be conducted by a CDM Smith project chemist or designee not directly involved with data collection or the site investigation. The EDD provided by the laboratory will be entered into a proprietary Microsoft-Access based data validation software program developed by CDM Smith, and the software program will be used to identify data that should either be qualified or rejected for project use. Data qualifiers will be reconciled with outputs from the validation, and will be added to the final, validated data. A validation report of changed data qualifiers will be generated from the data validation software program.

Data will be evaluated relative to the criteria established in Section 5.1. The flagging criteria that will be applied is summarized in Tables 5-4 and 5-5. The data validation and usability report identifies any non-conformances and explains any limitations on data use.

## 5.3 Reconciliation with User Requirements (D3)

The QAM is responsible for implementing the system inputs to data quality. All data quality issues concerning field sampling efforts, laboratory analysis, data validation, database management, and data reporting will be referred to the QAM.

1 **5.3.1 Usability Report**

2 The project chemist will prepare the data validation and usability report. This report will include  
3 limitations of the data and recommendations on the usability of the laboratory data for decision  
4 making. The report findings will be presented so that the completion of project objectives and  
5 overall data quality can be verified for the sample results. The data validation and usability report  
6 will include the following:

- 7     ▪ **Introduction:** Summarizes the purpose of the QA review and validation process and the  
8       samples reviewed
- 9     ▪ **Analytical data:** Summarizes the number and types of samples collected, including field QC  
10       samples, analytical methods performed, and data evaluation purpose
- 11    ▪ **Findings:** Provides overall summaries of the data validation findings (for example, only the  
12       criteria exceedances that resulted in data qualification are discussed) specific for each  
13       analytical method
- 14    ▪ **Overall Assessment:** Provides a summary of the overall completeness of the data set and  
15       discusses any limitations in the use of the analytical data
- 16    ▪ Copies of all data validation reports

17 The data validation and usability report will assess only the laboratory data packages and EDDs. No  
18 assessment of sample collection and associated documentation will be performed as part of this  
19 report, since that is addressed in the field systems audit (Section 4.1.2.1). The data validation and  
20 usability report will be provided as an appendix to the interim RI report.

21 **5.3.2 Project-specific Measurement Performance Criteria**

22 The project-specific MPC are summarized in Tables 3-2 through 3-11.

**Table 5-3. Data Validation Process Summary for Field and Laboratory Results**

*Quality Assurance Project Plan, OU-2 Remedial Investigation 700 South 1600 East PCE Plume, Salt Lake City, Utah*

| <b>Validation Step Tier 2B/4</b> | <b>Validation Input</b>                           | <b>Description</b>  | <b>Responsible for Validation (Name, Organization)</b> |
|----------------------------------|---|---|--|
| 2B/4                             | Field logbook                                     | Sampling protocols followed as per QAPP, appropriate QC samples collected, proper preservation  | FTL  |
| 2B/4                             | Field analytical results and logbook              | Calibrations, blanks, duplicates all recorded and meet criteria   | FTL  |
| 2B/4                             | Sample location data (GPS coordinates)            | Northings, eastings and elevations traceable to all sample locations  | FTL  |
| 2B/4                             | Field originated NCRs/CARs                        | All issues properly documented, corrective actions implemented and effective  | FTL  |
| 2B/4                             | Field surveillance report                         | All issues properly documented, corrective actions implemented and effective  | FTL  |
| 2B/4                             | Chain-of-custody forms; sample receiving document | Sample IDs for laboratory data match the reported data, all samples have data reported for requested analysis unless noted in the narrative   | Project Chemist/QAM                                    |
| 2B/4                             | Analytical data package                           | Holding times met all method criteria   | Project Chemist/QAM                                    |
| 2B/4                             | Laboratory SOPs/reference methods QAPP MPC        | Review of dilutions and re-analyses results against reported data; when multiple analyses appropriate run was reported, proper units are reported   | Project Chemist/QAM                                    |
| 2B/4                             |   | Calibrations analyzed at required frequency and met criteria  | Project Chemist/QAM                                    |
| 2B/4                             |   | Comparison of QC sample results (such as surrogate, internal standards, spikes, and blanks) all match criteria in method and QAPP   | Project Chemist/QAM                                    |
| 2B/4                             |   | Blanks free of contamination; if analytes present > RDL samples properly qualified if sample concentration < 10x blank concentration  | Project Chemist/QAM                                    |
| 2B/4                             |   | Detection limits, project action limits met   | Project Chemist/QAM                                    |
| 4                                |   | Recalculation of ample results from the laboratory instrument responses, and comparison of recalculated results to laboratory reported results. Evaluate sample results by checking selected instrument output (e.g., chromatograms, mass spectra, atomic emission spectra, instrument background, interference corrections) for correct identification and quantitation of analytes (e.g., peak integrations, use of appropriate internal standards, elution order of analytes, and interferences) | Project Chemist/QAM                                    |
| 2B/4                             | Laboratory surveillance report                    | All issues properly documented, corrective actions implemented and effective  | Project Chemist/QAM                                    |
| 2B/4                             | Lab originated NCRs/CARs                          | All issues properly documented, corrective actions implemented and effective  | Project Chemist/QAM                                    |
| 2B/4                             | Memo about QAPP modifications                     | All issues properly documented, corrective actions implemented and effective  | Project Chemist/QAM                                    |
| 2B/4                             | Analytical EDDs                                   | All data reported in excel format; EDD verified against hard copy laboratory report   | Project Chemist/QAM                                    |

**Notes:**

CAR = corrective action report  
 EDD = electronic data deliverable  
 GPS = geographic positioning system  
 FTL = field team leader

ID = identification  
 MPC = measurement performance criteria  
 NCR = non-conforming report  
 QAPP = quality assurance project plan

QAM = quality assurance manager  
 RDL = representative detection limit  
 SOP = standard operating procedure

**Table 5-4. Data Validation Flagging Criteria for Organic Methods**

*Quality Assurance Project Plan, OU-2 Remedial Investigation 700 South 1600 East PCE Plume, Salt Lake City, Utah*

| Quality Control Check  | Evaluation  | Data Flag   | Samples Affected   |
|--|---|---|--|
| Holding Time   | Holding time exceeded for extraction or analysis  | J positive results; UJ non-detects  | Sample   |
|  | Holding time exceeded by a factor of two  | J positive results; R non-detects   |  |
| Sample Preservation  | Sample not preserved; or not analyzed within 7 days from sample collection (SW8260C VOA)  | J positive results; UJ non-detects; R non-detects based on professional judgement | Sample   |
| Sample Integrity   | Bubbles (> pea size) in VOA vial used for analysis  | J positive hits; UJ non-detects   | Sample   |
| Temperature  | > 6°C   | J positive results; UJ non-detects  | All samples in same cooler   |
| Initial Calibration  | RRF < 0.050 but > 0.01,   | J positive results, UJ non-detects  | All associated samples in analysis batch   |
|  | RRF < 0.010 for poor responders (SW8260C and SW8270D)   | J positive results, R non-detects   |  |
|  | Method specified calibration criteria exceeded (for example %RSD exceeds criteria <u>AND</u> calibration curve not used; <u>OR</u> calibration curve used, but with coefficient of correlation or determination < 0.99) | J positive results, UJ non-detects  |  |
| Calibration Verification (second-source and continuing calibration verification) | RRF < 0.050 but >0.01,  | J positive results, UJ non-detects  | All associated samples in analysis batch   |
|  | RRF < 0.010 for poor responders (SW8260C and SW8270D)   | J positive results, R non-detects   |  |
|  | %D > 20.0% with high recovery   | J positive results  |  |
|  | %D > 20.0% with low recovery  | J positive results, UJ non-detects  |  |
| Laboratory Control Sample  | %R > UCL  | J positive results  | All samples in preparation batch   |
|  | %R < LCL  | J positive results, UJ non-detects  |  |
|  | %R < 10%  | J positive results; R non-detects   |  |
|  | Analyte not included in LCS   | J positive results, UJ non-detects  |  |
| Calibration Blank<br>Method Blank  | Convert blank concentration to soil units, if applicable; multiply the highest blank concentration by 5   | U positive sample results < 5× highest blank concentration                        | All samples in preparation batch or analytical batch, whichever one applies, associated with method blank or calibration blank |
| Equipment Blank<br>Field Blank   |   |   | All samples, same site, matrix and date (water) or all samples, same site, matrix (soil) associated with equipment blank       |



**Table 5-4. Data Validation Flagging Criteria for Organic Methods**

*Quality Assurance Project Plan, OU-2 Remedial Investigation 700 South 1600 East PCE Plume, Salt Lake City, Utah*

| Quality Control Check | Evaluation   | Data Flag   | Samples Affected   |
|-----------------------|--|---|--|
| Trip Blank            |  |   | All samples shipped in the same cooler as the trip blank |
| <b>Matrix Spikes</b>  |  |   |  |
| % Recoveries          | %R > UCL   | J positive results  | MS analytes in parent sample and field duplicate, if any |
|                       | %R < LCL   | J positive results, UJ non-detects  |  |
|                       | %R < 10%   | J positive results; R non-detects   |  |
|                       | Analyte not included in MS or MSD  | J positive results; UJ non-detects (if warranted based on technical review) |  |
| RPDs                  | RPD > UCL  | J positive results  |  |
| <b>Surrogates</b>     |  |   |  |
| SW8260C/TO-15         | %R > UCL   | J positive results  | All analytes in sample                                   |
|                       | %R < LCL and none < 10%  | J positive results; UJ non-detects  |  |
|                       | %R < 10%   | J positive results; R non-detects   |  |
| SW8270D               | Two or more surrogates in same fraction with %R > UCL  | J positive results  | All analytes in same fraction in sample                  |
|                       | Two or more surrogates in same fraction with %R < LCL but not < 10%  | J positive results; UJ non-detects  |  |
|                       | Two or more surrogates in same fraction with %R < LCL and < 10%  | J positive results; R non-detects   |  |
| Internal Standards    | Area > UCL   | J positive results  | Associated analytes in sample                            |
|                       | Area < LCL but not < 10%   | J positive results; UJ non-detects  |  |
|                       | Area < 10%   | J positive results; R non-detects   |  |
| Field Duplicates      | Concentration of reported analytes are > 5× the reporting limit in either sample and RPD > UCL (30% for water samples; 50% for soil samples) | J positive results  | Field duplicate pair                                     |
|                       | One or both sample results < 5× the reporting limit and a difference of ±2× the reporting limit for water (±4× for soil)                     | J positive; UJ non-detect   |  |
| Confirmation          | RPD between primary and confirmation results > 25%   | J positive results  | Sample   |

**Table 5-4. Data Validation Flagging Criteria for Organic Methods**

*Quality Assurance Project Plan, OU-2 Remedial Investigation 700 South 1600 East PCE Plume, Salt Lake City, Utah*

| Quality Control Check  | Evaluation | Data Flag | Samples Affected |
|--|------------|-----------|------------------|
| Notes:   |            |           |                  |
| All QA/QC criteria are included in Tables 3-2 through 3-13 and will be used for verification criteria.   |            |           |                  |
| Organic methods include SW8260C, SW8270D, and TO-15.   |            |           |                  |
| Spike recovery limits do not apply when sample concentration exceeds the spike concentration by a factor of 4 or more.   |            |           |                  |
| For methods requiring confirmation, the qualification applies to primary analysis results (either of the two columns/detectors may be designated as the primary column/detector).  |            |           |                  |
| Where one MS recovery meets acceptance criteria and the other MS of the pair does not, professional judgment may be used to determine if the parent sample should be qualified for matrix effects by comparing the MS recoveries to other QC results within the batch or sample site.              |            |           |                  |
| Qualifier may not apply in cases where a surrogate coelutes with a non-target analyte.   |            |           |                  |
| Qualifier may not apply in cases where low surrogate recoveries are because of sample dilution.  |            |           |                  |
| %D = percent difference  |            |           |                  |
| %R = percent recovery  |            |           |                  |
| °C = degree(s) Celsius   |            |           |                  |
| J = The analyte was positively identified. The associated numerical value is the approximate concentration of the analyte in the sample, or the reported concentration is greater than the instrument detection limit, but less than the quality assurance project plan specified reporting limit. |            |           |                  |
| LCL = lower control limit  |            |           |                  |
| MB = method blank  |            |           |                  |
| MS = matrix spike  |            |           |                  |
| QA = quality assurance   |            |           |                  |
| QC = quality control   |            |           |                  |
| R = The sample results are rejected due to serious deficiencies in the ability to analyze the sample and meet quality control criteria. The presence or absence of the analyte cannot be verified.   |            |           |                  |
| RPD = relative percent difference  |            |           |                  |
| RRF = relative response factor   |            |           |                  |
| RSD = relative standard deviation  |            |           |                  |
| U = The compound was analyzed for, but was not detected above, the reported method detection limit.  |            |           |                  |
| UCL = upper control limit  |            |           |                  |
| UJ = The analyte was not detected above the reported method detection limit. However, the reported limit is approximate and may or may not represent the actual limit of quantitation necessary to accurately and precisely measure the analyte in the sample.                                     |            |           |                  |
| VOA = volatile organic analytic  |            |           |                  |

**Table 5-5. Data Validation Flagging Criteria for Inorganic Methods**

*Quality Assurance Project Plan, OU-2 Remedial Investigation 700 South 1600 East PCE Plume, Salt Lake City, Utah*

| Quality Control Check  | Evaluation  | Flag   | Samples Affected  |
|--|---|--|---|
| Holding Time   | Holding time exceeded for extraction, digestion, or analysis  | J positive results; R non-detects for mercury; UJ non-detects for all other analytes | Sample  |
|  | Holding time for digestion or analysis exceeded by a factor of 2  | J positive results; R non-detects  |   |
| Sample Preservation  | Sample preservation requirements not met (If sample preservation was not done in the field, but was performed at the laboratory upon sample receipt, no flagging is required) | J positive results; R non-detects  | Sample  |
| Temperature  | >6°C (not applicable to metals except mercury)  | J positive results; UJ non-detects   | Samples in same cooler  |
| Initial Calibration (multi-point only)   | Correlation coefficient $\leq 0.995$  | J positive; UJ non-detects   | All associated samples in analytical batch                                  |
| Calibration Verification (initial calibration verification, continuing calibration verification) | %R > 110, except ICV SM4500-NO3E (115)  | J positive results   | All associated samples in analytical batch                                  |
|  | %R < 90, except ICV SM4500-NO3E (85)  | J positive results, UJ non-detects   |   |
| Interference Check Sample (SW6020 only)  | %R > UCL  | J positive results   | All associated samples in analytical batch                                  |
|  | %R < LCL  | J positive results; UJ non-detects   |   |
| Low Level Calibration Verification-SW6020 only   | %R >130   | J positive results   | All associated samples in analytical batch                                  |
|  | %R<30   | J positive results, UJ non-detects   |   |
| Laboratory Control Sample  | %R > UCL  | J positive results; no action for non-detects  | All samples in preparation batch  |
|  | %R < LCL  | J positive results; UJ non-detects   |   |
|  | %R < 40% (< 20% for Antimony or Silver)   | J positive results; R non-detects  |   |
|  | Analyte not included in LCS   | J positive results, UJ non-detects   |   |
| Internal Standards (SW6020A)   | Area >125%  | J positive results; UJ non-detects   | Associated analytes in sample   |
|  | Area <60 but not <30%   | J positive results; no action for non-detects  |   |
|  | Area <30%   | R positive results; Non-detects use professional judgment – UJ or R                  |   |
| Method Blank   | Convert blank concentration to soil units, if applicable; multiply the highest blank concentration by 5   | U positive sample results < 5× highest blank concentration                           | All samples in preparation batch or analytical batch, whichever one applies |

**Table 5-5. Data Validation Flagging Criteria for Inorganic Methods**

*Quality Assurance Project Plan, OU-2 Remedial Investigation 700 South 1600 East PCE Plume, Salt Lake City, Utah*

| Quality Control Check                             | Evaluation  | Flag   | Samples Affected   |
|---|---|--|--|
| Calibration Blank (ICB, CCB)                      | Convert blank concentration to soil units, if applicable; multiply the highest blank concentration by 5                     | Positive blank detections:<br>U detected sample results < 5x highest blank concentration<br><br>Negative blank detections<br>J positive sample result < 10x  -ccb  (absolute value)<br>"None" positive sample result > 10x  -ccb  (absolute value)<br>UJ non-detects | All samples that are either before or after the CCB/ICB  |
| Equipment Blank<br>Field Blank<br>Ambient Blank   | Convert blank concentration to soil units, if applicable; multiply the highest blank concentration by 5                     | U positive sample results < 5x highest blank concentration<br><br>No action for positive sample results >5x highest blank concentration  | All samples, same site, matrix and date (water) or all samples, same site, matrix (soil) associated with equipment blank |
| <b>Matrix Spikes</b>                              |   |  |  |
| % Recoveries                                      | %R > UCL  | J positive results   | MS analytes in parent sample and field duplicate, if any   |
|   | %R < LCL  | J positive results, UJ non-detects   |  |
|   | %R < 30%  | J positive results; R non-detects  |  |
|   | Analyte not included in MS or MSD   | J positive results, UJ non-detects   |  |
| RPDs  | RPD > UCL   | J positive results   |  |
| Dilution Test                                     | If concentration is > 50 times the MDL and percent difference > UCL   | J positive results, UJ non-detects   | Parent sample result(s)  |
| Post-digestion Spikes/Recovery Test (metals only) | %R > UCL  | J positive   | Parent sample result(s)  |
|   | %R < LCL  | J positive results, UJ non-detects   |  |
| Field Duplicates                                  | Concentration of reported analytes are > 5x RL in either sample and RPD > UCL (30% for water samples; 50% for soil samples) | J positive results   | Field duplicate pair   |
|   | One or both sample results < 5x RL and a difference of ±2x the reporting limit for water (±4x for soil).                    | J positive; UJ non-detect  |  |
| Laboratory Sample Duplicates                      | Concentration of reported analytes are > 5x RL in either sample and RPD > 20%   | J positive results   | Parent sample result(s)  |
|   | One or both sample results < 5x RL and a difference of ±2x the reporting limit  | J positive results, UJ non-detects   |  |

**Table 5-5. Data Validation Flagging Criteria for Inorganic Methods**

*Quality Assurance Project Plan, OU-2 Remedial Investigation 700 South 1600 East PCE Plume, Salt Lake City, Utah*

| Quality Control Check  | Evaluation | Flag | Samples Affected |
|--|------------|------|------------------|
| Notes:   |            |      |                  |
| All QA/QC criteria are included in Tables 3-2 through 3-13 and will be used for verification criteria.   |            |      |                  |
| Inorganic methods include SW6010C, SW6020A, SW7470A, SW7471A, and General Chemistry Parameters.  |            |      |                  |
| Spike recovery limits do not apply when sample concentration exceeds the spike concentration by a factor of 4 or more.   |            |      |                  |
| %R = percent recovery  |            |      |                  |
| °C = degree(s) Celsius   |            |      |                  |
| J = The analyte was positively identified. The associated numerical value is the approximate concentration of the analyte in the sample, or the reported concentration is greater than the instrument detection limit, but less than the quality assurance project plan specified reporting limit. |            |      |                  |
| LCL = lower control limit  |            |      |                  |
| MS = matrix spike  |            |      |                  |
| MSA = method of standard addition  |            |      |                  |
| QA = quality assurance   |            |      |                  |
| QC = quality control   |            |      |                  |
| R = The sample results are rejected due to serious deficiencies in the ability to analyze the sample and meet quality control criteria. The presence or absence of the analyte cannot be verified.   |            |      |                  |
| RPD = relative percent difference  |            |      |                  |
| U = The compound was analyzed for, but was not detected above, the reported method detection limit.  |            |      |                  |
| UCL = upper control limit  |            |      |                  |
| UJ = The analyte was not detected above the reported method detection limit. However, the reported limit is approximate and may or may not represent the actual limit of quantitation necessary to accurately and precisely measure the analyte in the sample.                                     |            |      |                  |



# Section 6

## References

- CH2M HILL, Inc. (CH2M). 2017. *Data Management Plan, OU-2 Remedial Investigation, 700 South 1600 East PCE Plume, Salt Lake City, Utah*. Final. May.
- CH2M HILL, Inc. (CH2M). 2018. *Remedial Investigation Work Plan, OU-2 Remedial Investigation, 700 South 1600 East PCE Plume, Salt Lake City, Utah*. Final. February.
- Jacobs Engineering Group Inc. (Jacobs). 2018. *Replacement of Empirical Laboratories with EMAX Laboratories*. September.
- U.S. Army Corps of Engineers (USACE). 2005. *Guidance for Evaluating Performance Based Chemical Data*. Engineer Manual 200-1-10. June.
- U.S. Department of Defense (DoD). 2017. *Quality Systems Manual*. Version 5.1. January.
- U.S. Environmental Protection Agency (EPA). 1988. *Guidance for Conducting Remedial Investigations and Feasibility Studies under the Comprehensive Environmental Response Compensation and Liability Act (CERCLA)*. Interim Final. October.
- U.S. Environmental Protection Agency (EPA). 2001. *EPA Requirements for Quality Assurance Project Plans*. EPA QA/R-5. EPA/240/B-01/003. March. Reissued 2006.
- U.S. Environmental Protection Agency (EPA). 2002. *EPA Guidance for Quality Assurance Project Plans*. EPA QA/G-5. EPA/600/R-02/009. December.
- U.S. Environmental Protection Agency (EPA). 2005. *Uniform Federal Policy for Quality Assurance Project Plans*. EPA/505/B-04/900A. March.
- U.S. Environmental Protection Agency (EPA). 2006. *Guidance on Planning Using the Data Quality Objectives Process*. EPA QA/G-4. Printing Office. Washington, DC. February.
- U.S. Environmental Protection Agency (EPA). 2009. *Guidance for Labeling Externally Validated Laboratory Analytical Data for Superfund Use*. EPA/540/R-08/005. January.
- U.S. Environmental Protection Agency (EPA). 2017a. *EPA Contract Laboratory Program National Functional Guidelines for Inorganic Superfund Data Review*. EPA/540/R-13/001. January.
- U.S. Environmental Protection Agency (EPA). 2017b. *EPA Contract Laboratory Program National Functional Guidelines for Superfund Organic Methods Data Review*. EPA/540/R-014/002. January.
- U.S. Environmental Protection Agency (EPA). 2017. *Regional Screening Levels (RSLs) – User’s Guide*. Accessed December 22, 2017. <https://www.epa.gov/risk/regional-screening-levels-rsls-users-guide-november-2017>.





---

# Appendix A

## Standard Operating Procedures

**Surface Water Sampling**

SOP 1-1

Revision: 10

Date: February 2015

Approved :

  
 Signature

Technical Review:

Curt Coover

**1.0 Objective**

The purpose of this technical standard operating procedure (SOP) is to define requirements for collection and containment of surface water samples.

**2.0 Background**

Surface water samples are collected to determine the type(s) and level(s) of contamination in a particular surface water body and/or its biological disposition.

**2.1 Definitions**

**Surface Water** - Water that flows over or rests on the land and is open to the atmosphere. This includes ditches, streams, rivers, lakes, pools, ponds, and basins.

**Shallow Surface Water** - Water within 1 to 3.3 feet (0.3 to 1 meter) of the surface of a body of water.

**Deep Surface Water** - Water deeper than 3.3 feet (1 meter) of the surface of a body of water.

**Grab Sample** - A discrete portion or aliquot taken from a specific location at a given point in time.

**Simple Composite** - Two or more subsamples taken from a specific media and site at a specific point in time. The subsamples are collected and mixed, and then a single average sample is taken from the mixture.

**Temporal Composite** - Two or more subsamples taken from a specific media and site over a period of time. The subsamples are collected and mixed, and then a single average sample is taken from the mixture.

**Churn Splitter** - Large vessel for compositing subsamples. Includes a mechanism to agitate the water to keep solids suspended.

**2.2 Associated Procedures**

- SOP 1-2, *Sample Custody*
- SOP 2-1, *Packaging and Shipping Environmental Samples*
- SOP 4-1, *Field Logbook Content and Control*
- SOP 4-2, *Photographic Documentation of Field Activities*
- SOP 4-5, *Field Equipment Decontamination at Nonradioactive Sites*

**3.0 General Responsibilities**

**Site Manager** - The site manager is responsible for ensuring that field personnel are trained in the use of this SOP, related SOPs, and the required equipment.

**Field Team Leader** - The field team leader (FTL) is responsible for ensuring that sampling efforts are conducted in accordance with this procedure and any other SOPs pertaining to specific media sampling. The FTL also must ensure that the quantity and location of surface water samples collected meet the requirements of the site-specific plans.

**Note:** Responsibilities may vary from site to site. Therefore, all field team member responsibilities shall be defined in the field plan or site/quality assurance project plan (QAPP).

## Surface Water Sampling

SOP 1-1

Revision: 10

Date: February 2015

### 4.0 Required Equipment

All or part of the equipment listed under the “as needed” category may be required at any specific site, depending on the plan(s) for that site.

- Site-specific plans
- Field logbook
- Indelible black-ink pens and markers
- Labels and appropriate forms/documentation for sample shipment
- Appropriate sample containers
- Insulated cooler and waterproof sealing tape
- Ice bags or “blue ice”
- Plastic zip-top bags
- Clear waterproof tape
- Personal protective clothing and equipment
- Latex or appropriate gloves
- Rubber boots and/or rubberized waders
- Life jacket
- Kimwipe or paper towels
- Clean plastic sheeting
- Tap and deionized water
- Appropriate photographic equipment and supplies
- Appropriate decontamination equipment and supplies

As needed:

- Pond sampler with 1-liter (L) beaker (preferably Teflon<sup>®</sup>), clamp, and heavy-duty telescoping pole
- Weighted bottle sampler, 1-L capacity (preferably Teflon) and handle; see USGS Open File Report 2005-1087 for selection of sampler; a Kemmerer or Van Dorn sampler may be used if Teflon is not required
- Churn splitter
- Peristaltic pump or suitable replacement
- Temperature, pH, and conductivity meter(s), dissolved oxygen meter, redox potential meter (as required by project plan)
- Boat with depth finder for deep water or inaccessible shorelines
- Global positioning system (GPS) unit
- Tape measure
- Any personal protective equipment specified in the site-specific health and safety plan
- Spare parts for all equipment

## 5.0 Procedures

### 5.1 Preparation

The following steps should be taken when preparing for sampling surface water:

1. Review site-specific health and safety plan and project plans before initiating sampling activity.
2. Don the appropriate personal protective clothing as dictated by the site-specific health and safety plan.
3. Select wadeable stream/river sampling locations that exhibit cross-sectional homogeneity and are well-mixed. Avoid areas where the channel is constricted or bends where scouring may have occurred. For lake samples, the investigator should consider the lake stratification caused by seasonal temperature differences. If possible, select a location that can be described precisely, such as xx feet upstream of xx bridge. Use caution when wading streams more than 1 to 2 feet deep. Flowing water can be a safety hazard.
4. Prepare sampling site by laying out clean plastic sheeting on the ground or any flat, level surfaces near the sampling area and place equipment to be used on the plastic.
5. Make field measurements as required by the project plans in physical, chemical, and biological characteristics of the water (e.g., discharge, gage height, temperature, dissolved oxygen, conductivity, pH).

**Surface Water Sampling**

SOP 1-1

Revision: 10

Date: February 2015

6. The samples shall be collected from areas of least to greatest contamination (when known) and, when collecting several samples in 1 day, always collect from downstream to upstream.
7. The sampler should be facing upstream when sampling, both for proper sample collection and for safety (ability to observe floating objects).
8. Document the sampling events, recording all information in the designated field logbook and take photographs if required or if possible. Document any and all deviations from this SOP and include rationale for changes.
9. The collection points shall be located on a site map and described in the field logbook. Use GPS if required or if possible.
10. Label each sample container with the appropriate information. Secure the label by covering it with a piece of waterproof clear tape.
11. Decontaminate reusable sampling equipment after sample collection according to SOP 4-5.
12. Processes for verifying depth of samples must be included in site-specific project plans.
13. Check that a trip blank/temperature blank, when necessary, is included in the chilled cooler. Quality assurance/quality control sample requirements vary from project to project. Consult the project-specific work plan for quality requirements.

**5.2 Shallow Surface Water Sample Collection for Wadeable Streams****5.2.1 Method for Collecting Samples for Volatile Organic Compound Analysis**

All volatile organic compound (VOC) samples should be discrete samples. The following steps must be taken when collecting shallow surface water VOC samples:

If the volatile organic analysis (VOA) vials do not require a preservative:

1. Approach the sample location from downstream; do not enter the sample area. Slowly submerge VOA vials completely into an area of gently flowing water and fill. Do not disturb bottom sediments. The open end of the vials should be pointed upstream

**Note:** When collecting samples for VOC analysis, avoid collecting from a surface water point where water is cascading and aerating.

2. Cap the VOA vial while it is underwater. Be sure to dislodge all air bubbles from the cap before sealing the vial.
3. Turn the capped vial upside down and check for air bubbles. Tap the bottom of the vials to dislodge any bubbles that may have formed around the cap or sides. Discard and resample if bubbles are present.
4. Proceed to Step 5 below.

If the VOA vials require a preservative:

1. Collect a sufficient sample in a clean glass jar as in Steps 1 and 2 above for unpreserved vials. Specific sampling devices to be used must be specified in site-specific plans.
2. Decant the sample immediately into prepreserved VOA vials. It is recommended that the amount of preservative be predetermined on a separate aliquot of sample that is subsequently discarded. Tip vials slightly while filling to reduce turbulence until nearly filled. Then straighten vial to vertical for final filling. Ensure that a meniscus is raised above the lip of the vial before capping.
3. Cap each vial once the meniscus has formed.

**Surface Water Sampling**

SOP 1-1

Revision: 10

Date: February 2015

4. Turn the capped vial upside down and check for air bubbles. Tap the bottom of the vials to dislodge any bubbles that may have formed around the cap or sides. Discard and resample if bubbles are present.
5. Wipe the outside of sample vials with a Kimwipe or clean paper towel. Affix a completed sample label.
6. Place sample vial(s) in a zip-top plastic bag and seal the bag.
7. Immediately pack all samples into a chilled cooler.

**5.2.2 Method for Collecting Discrete Shallow Surface Water Samples for Nonvolatile Organic or Inorganic Compound Analysis**

The following steps must be followed when collecting discrete shallow surface water samples for nonvolatile organic or inorganic compound analysis:

1. Directly dip the sample container, with the opening facing upstream, into the surface water and fill. If wading is necessary, approach the sample location from downstream; do not enter the actual sample area. Do not disturb underlying sediments.
2. Filter samples if required by the site-specific plan.
3. Add appropriate preservatives to the sample containers if required and check pH.

**Note:** Use a separate container when field testing pH, conductivity, temperature, etc. Do not insert pH paper or probe directly into sample container.

4. Cap the sample containers and wipe the outer surfaces of the sample containers clean with a Kimwipe or clean paper towel. Affix a completed sample label.
5. Place sample container(s) in individual zip-top plastic bags, if possible, and seal the bags.
6. Immediately pack all samples into a chilled cooler.

**5.2.3 Method for Collecting Simple Composite Shallow Surface Water Samples for Nonvolatile Organic or Inorganic Compound Analysis**

If the QAPP requires the use of simple composite samples, then a sampler capable of collecting composite samples is required. For width and depth integrated (WDI) composite samples, a DH-48 or DH-81 are recommended, but the QAPP may specify an alternative. The following steps must be followed when collecting simple composite shallow surface water samples for nonvolatile organic or inorganic compound analysis:

1. Record the gage height, if any, before and after sampling.
2. Select the number of width increments based on the requirements of the QAPP. Generally, small well mixed streams require few increments while large or poorly mixed streams require more increments.
3. For fewer than six width increments, subsample locations can be visually estimated. For more than five width increments, string a tape measure across the stream above the water surface to be able to accurately identify the subsample locations. Increments should be evenly spaced across the stream for equal width-integrated (EWI) sampling.

**Surface Water Sampling**

SOP 1-1

Revision: 10

Date: February 2015

4. If depth-integrated sampling is required, collect a subsample at each width increment by submerging the sampler, orifice facing upstream, from the surface to near the bottom and back up to the surface again in an even steady motion. Do not disturb the sediment at the bottom. The sampler should be retrieved less than full. If the sampler is full, empty it and repeat the subsample collection.
5. If depth-integrated sampling is not required, submerge the sampler with the orifice facing upstream into the surface water and fill.
6. Empty the sampler into a churn splitter or temporary container for later splitting.
7. Repeat Steps 4 to 6 for each width increment.
8. If temporary containers were used, empty into churn splitter. Operate the churn splitter by moving the churn up and down in a steady motion fast enough to homogenize the sample without causing aeration. While the churn is in motion, fill the sample bottles from the tap on the churn.
9. Follow Steps 2 through 6 in Section 5.2.2.

#### **5.2.4 Method for Collecting Temporal Composite Shallow Surface Water Samples for Nonvolatile Organic or Inorganic Compound Analysis**

If the QAPP requires the use of temporal composite samples, this can be accomplished using a series of discrete samples collected by hand or an automated sampler, or using a series of simple composite samples. Refer to the preceding sections for collecting the subsamples. The compositing scheme can be time-based (e.g., once per hour for 4 hours) or time-discharge (or time gage height) based (e.g., once per hour until the gage height exceeds xx feet, then change to once per 15 minutes).

Because of the project-specific nature of temporal composite sampling, the specific requirements should be identified in the QAPP. The following are general steps to be followed to collect temporal composite samples:

1. Provide for a method of measuring discharge or gage height before, during, and after sample collection as required in the QAPP.
2. Select the number of time increments based on the requirements of the QAPP. If the time increments change based on a change in flow or water quality, specify the trigger, the new time increment, and any additional trigger to return to the previous increment.
3. Calculate the storage volume for the subsamples and provide a churn splitter of adequate size to contain the entire sample to be composited.
4. Collect the samples according to a method described in this SOP or alternate specified in the QAPP.
5. Provide for cold storage of subsamples, if possible. Do not process any subsamples by filtering or preserving unless specified in the QAPP.
6. Following collection of all subsamples, empty the containers into a churn splitter. If discrete data are required including laboratory or field analysis, retain a portion of the subsample.
7. Operate the churn splitter by moving the churn up and down in a steady motion fast enough to homogenize the sample without causing aeration. While the churn is in motion, fill the sample bottles from the tap on the churn.
8. Follow Steps 2 through 6 in Section 5.2.2.

**Surface Water Sampling**

SOP 1-1

Revision: 10

Date: February 2015

9. Field parameters should be measured in the surface water at the time of collection. Some field parameters can be measured on the subsamples at the time of compositing, but the temperature and temperature-dependant parameters will not be representative.

**5.3 Deep Surface Water Sample Collection****5.3.1 Method for Collecting Samples at Specified Depth Using a Weighted Bottle Sampler**

The following steps must be followed when collecting surface water samples at specific depths using a weighted bottle sampler:

1. Lower the weighted bottle sampler to the depth specified in the site-specific plan.
2. Remove the stopper by pulling on the sampler line; allow the sampler to fill with water.
3. Release the sampler line to reseal the stopper and retrieve the sampler to the surface.
4. Wipe the weighted bottle sampler dry with a Kimwipe or clean paper towel.
5. Remove the stopper slowly. Fill the specified number of sample containers by slightly tipping the sampler against each sample bottle. Samples to be used for VOC analysis should be decanted directly from the sampler first into prepreserved VOA vials. It is recommended that the amount of preservative be predetermined on a separate aliquot of sample that is subsequently discarded. Add appropriate preservatives to the other sample containers and check pH. Samples may be pooled in stainless steel, glass, or Teflon containers to obtain the necessary volumes. Filter samples if required. Collect sample in separate container for pH, conductivity, temperature, and other measurements if necessary.
6. Close each sample container with the Teflon-lined cap once it is filled. Check for air bubbles in the VOC sample containers. If bubbles are present, discard and resample.
7. Wipe the outside of the sample containers clean with a Kimwipe or clean paper towel. Affix a completed sample label.
8. Place sample container(s), if possible, in individual zip-top plastic bags, and seal the bags.
9. Immediately pack all samples into a chilled cooler.

**5.3.2 Method for Deep Surface Water Sample Collection Using a Peristaltic Pump**

The following steps must be followed when collecting deep surface water samples using a peristaltic pump:

1. Install clean medical-grade silicon or Teflon tubing on the pump head. Leave sufficient tubing on the discharge side for convenient dispensing of liquid directly into sample containers.
2. Select the appropriate length of Teflon intake tubing necessary to reach the specified sampling depth. Attach the intake sampling tube to the intake pump tube.
3. Lower the intake tube into the surface water at the specified sampling location to the specified depth; make sure the end of the intake tube does not touch underlying sediments.
4. Start the pump and allow at least three tubing volumes of liquid to flow through and rinse the system before collecting any samples. Do not immediately dispense the purged liquid back to the surface water body. Instead, collect the purged liquid and return it to the source after sample collection is complete.
5. Fill the specified number of sample containers directly from the discharge line. Filter samples if required by the site-specific plan. While filling, allow the liquid to flow gently down the inside of the sample bottle to minimize turbulence.

## Surface Water Sampling

SOP 1-1

Revision: 10

Date: February 2015

For VOC samples, fill prepreserved VOA vials and allow a meniscus to form above the top of the container before capping. It is recommended that the amount of preservative be predetermined on a separate aliquot of sample that is subsequently discarded. Check VOA vials to ensure that there are no air bubbles. Add appropriate preservatives to the other samples and check pH.

**Note:** Use a separate container when field-testing pH, conductivity, temperature, etc. Do not insert pH paper or probe directly into sample container.

6. Cap the sample container(s). Wipe the outside of sample containers clean with a Kimwipe or clean paper towel. Affix a completed sample label.
7. Place sample container(s) in individual zip-top plastic bags and seal the bags.
8. Immediately pack all samples into a chilled cooler.
9. Drain the pump system, rinse it with deionized water, and wipe it dry. Replace all tubing with new tubing before sampling at another sampling location. Place all used tubing in plastic bags to be discarded or decontaminated according to the site-specific plans.

### 6.0 Restrictions/Limitations

Peristaltic pumps are generally not capable of lifting water distances greater than 20 to 25 feet (6 to 7.5 meters) above the normal hydrostatic level.

Grab sampling for VOC analysis or for analysis of any other compound(s) that may be degraded by aeration is necessary to minimize sample disturbance and, hence, analyte loss. The representativeness of this sample, however, is difficult to determine because the collected sample represents a single point and has been disturbed.

### 7.0 References

\_\_\_\_\_. Region 4. *Operating Procedure, Surface Water Sampling*, Science and Ecosystem Support Division. February 28, 2013 or current revision.

U. S. Geological Survey. *National Field Manual for the Collection of Water-Quality Data, Chapter A4*. Version 2.0 September 2006.

\_\_\_\_\_. A Guide to the Proper Selection and Use of Federally Approved Sediment and Water Quality Samplers. Open-File Report 2005-1087. 2005.



**Sample Custody**

SOP 1-2

Revision: 8

Date: February 2015

Approved:

  
Signature

Technical Review:

Scott Kirchner

**1.0 Objective**

Because of the evidentiary nature of samples collected during environmental investigations, possession must be traceable from the time the samples are collected until their derived data are introduced as evidence in legal proceedings. To maintain and document sample possession, sample custody procedures are followed. All paperwork associated with the sample custody procedures will be retained in CDM Smith files unless the client requests that it be transferred to them for use in legal proceedings or at the completion of the contract.

**Note:** Sample custody documentation requirements vary with the specific EPA region or client. This technical standard operating procedure (SOP) is intended to present basic sample custody requirements, along with common options. Specific sample custody requirements shall be presented in the project-specific quality assurance (QA) project plan or project-specific modification or clarification form (see Section U-1).

**2.0 Background****2.1 Definitions**

**Sample** - A sample is material to be analyzed that is contained in single or multiple containers representing a unique sample identification number.

**Sample Custody** - A sample is under custody if:

1. It is in your possession
2. It is in your view, after being in your possession
3. It was in your possession and you locked it up
4. It is in a designated secure area

**Chain-of-Custody Record** - A chain-of-custody record is a form used to document the transfer of custody of samples from one individual to another.

**Custody Seal** - A custody seal is a tape-like seal that is part of the chain-of-custody process and is used to detect tampering with samples after they have been packed for shipping.

**Sample Label** - A sample label is an adhesive label placed on sample containers to designate a sample identification number and other sampling information.

**Sample Tag** - A sample tag is attached with string to a sample container to designate a sample identification number and other sampling information. Tags may be used when it is difficult to physically place adhesive labels on the container (e.g., in the case of small air sampling tubes). Check with your EPA regional Contract Laboratory Program (CLP) coordinator as not all Regions require sample tags.

**3.0 General Responsibilities**

**Sampler** - The sampler is personally responsible for the care and custody of the samples collected until they are properly transferred or dispatched.

**Field Team Leader** - The field team leader (FTL) is responsible for ensuring that strict chain-of-custody procedures are maintained during all sampling events. The FTL is also responsible for coordinating with the subcontractor laboratory to ensure that adequate information is recorded on custody records. The FTL determines whether proper custody procedures were followed during the fieldwork.

**Sample Custody**

SOP 1-2

Revision: 8

Date: February 2015

**Field Sample Custodian** - The field sample custodian, when designated by the FTL, is responsible for accepting custody of samples from the sampler(s) and properly packing and shipping the samples to the laboratory assigned to do the analyses. A field sample custodian is typically designated only for large and complex field efforts.

**Note:** Responsibilities may vary from site to site. Therefore, all field team member responsibilities shall be defined in the field plan or site/quality assurance project plan (QAPP).

**4.0 Required Supplies**

- Chain-of-custody records (applicable client or CDM Smith forms)
- Sample labels and/or tags
- Scribe software (if required)
- Custody seals
- Clear tape
- Computer
- Printer and paper

**5.0 Procedures****5.1 Chain-of-Custody Record**

This procedure establishes a method for maintaining custody of samples through use of a chain-of-custody record. This procedure will be followed for all samples collected or split samples accepted.

**Field Custody**

1. Collect only the number of samples needed to represent the media being sampled. To the extent possible, determine the quantity and types of samples and sample locations before the actual fieldwork. As few people as possible shall handle samples.
2. Complete sample labels or tags for each sample using waterproof ink.
3. Maintain personal custody of the samples (in your possession) at all times until custody is transferred for sample shipment or directly to the analytical laboratory.

**Transfer of Custody and Shipment**

1. Complete a chain-of-custody record for all samples (see Figure 1 for an example of a chain-of-custody record. Similar forms may be used when requested by the client). When transferring the possession of samples, the individuals relinquishing and receiving will sign, date, and note the time on the record. This record documents sample custody transfer from the sampler, often through another person, to the sample custodian in the appropriate laboratory.
  - The date/time will be the same for both signatures when custody is transferred directly to another person. When samples are shipped via common carrier (e.g., Federal Express), the date/time will not be the same for both signatures. Common carriers are not required to sign the chain-of-custody record.
  - In all cases, it must be readily apparent that the person who received custody is the same person who relinquished custody to the next custodian.
  - If samples are left unattended or a person refuses to sign, this must be documented and explained on the chain-of-custody record.

**Note:** If a field sample custodian has been designated, he/she may initiate the chain-of-custody record, sign, and date as the relinquisher. The individual sampler(s) must sign in the appropriate block, but does (do) not need to sign and date as a relinquisher (refer to Figure 1).

2. Package samples properly for shipment and dispatch to the appropriate laboratory for analysis. Each shipment must be accompanied by a separate chain-of-custody record. If a shipment consists of multiple coolers, a chain-of-custody record shall be filled out for each cooler documenting only samples contained in that particular cooler.

**Sample Custody**

SOP 1-2

Revision: 8

Date: February 2015

3. The original record will accompany the shipment, and the copies will be retained by the FTL and, if applicable, distributed to the appropriate sample coordinators. Freight bills will also be retained by the FTL as part of the permanent documentation. The shipping number from the freight bill shall be recorded on the applicable chain-of-custody record and field logbook in accordance with SOP 4-1, Field Logbook Content and Control.

**Procedure for Completing CDM Smith Example Chain-of-Custody Record**

The following procedure is to be used to fill out the CDM Smith chain-of-custody record. The record provided herein (Figure 1) is an example chain-of-custody record. If another type of custody record (i.e., provided by the EPA Contract Laboratory Program (CLP) or a subcontract laboratory or generated by Scribe) is used to track the custody of samples, the custody record shall be filled out in its entirety.

1. Record project number.
2. Record FTL for the project (if a field sample custodian has been designated, also record this name in the "Remarks" box).
3. Record the name and address of the laboratory to which samples are being shipped.
4. Enter the project name/location or code number.
5. Record overnight courier's airbill number.
6. Record sample location number.
7. Record sample number.
8. Note preservatives added to the sample.
9. Note media type (matrix) of the sample.
10. Note sample type (grab or composite).
11. Enter date of sample collection.
12. Enter time of sample collection in military time (24 hour clock).
13. When required by the client, enter the names or initials of the samplers next to the sample location number of the sample they collected.
14. List parameters for analysis and the number of containers submitted for each analysis.
15. Enter appropriate designation for laboratory quality control (e.g., matrix spike/matrix spike duplicate [MS/MSD], matrix spike/duplicate [MS/D]), or other remarks (e.g., sample depth).
16. Sign the chain-of-custody record(s) in the space provided. All samplers must sign each record.
17. If sample tags are used, record the sample tag number in the "Remarks" column.
18. The originator checks information entered in Items 1 through 16 and then signs the top left "Relinquished by" box, prints his/her name, and enters the current date and time (military).
19. Send the top two copies (usually white and yellow) with the samples to the laboratory; retain the third copy (usually pink) for the project files. Retain additional copies for the project file or distribute as required to the appropriate sample coordinators.
20. The laboratory sample custodian receiving the sample shipment checks the sample label information against the chain-of-custody record. Sample condition is checked and anything unusual is noted under "Remarks" on the chain-of-custody record. The laboratory custodian receiving custody signs in the adjacent "Received by" box and keeps the copy. The white copy is returned to CDM Smith.

**5.2 Sample Labels and Tags**

Unless the client directs otherwise, sample labels or tags will be used for all samples collected or accepted for CDM Smith projects.

1. Complete one label or tag with the information required by the client for each sample container collected. A typical label or tag would be completed as follows (see Figure 2 for example of sample tag; labels are completed with the equivalent information):
  - Record the project code (i.e., project or task number).
  - Enter the station number (sample number or EPA CLP identification number) if applicable.
  - Record the date to indicate the month, day, and year of sample collection.
  - Enter the time (military) of sample collection.
  - Place a check to indicate composite or grab sample.

**Sample Custody**

SOP 1-2

Revision: 8

Date: February 2015

- Record the station (sample) location.
  - Sign in the space provided.
  - Place a check next to “yes” or “no” to indicate if a preservative was added.
  - Place a check under “Analyses” next to the parameters for which the sample is to be analyzed. If the desired analysis is not listed, write it in the empty slot. Note: Do not write in the box for “laboratory sample number.”
  - Place or write additional relevant information under “Remarks.”
2. Place adhesive labels directly on the sample containers. Place clear tape over the label to protect from moisture.
  3. Securely attach sample tags to the sample bottle if required. On 2.27 liter (80 oz.) amber bottles, the tag string may be looped through the ring-style handle and tied. On all other containers, it is recommended that the string be looped around the neck of the bottle, then twisted, and relooped around the neck until the slack in the string is removed. In some instances, when the tag cannot be physically attached to the sample container, it is acceptable to simply place the sample tag in the zip lock bag with a sample container.
  4. Double-check that the information recorded on the sample label or tag is consistent with the information recorded on the chain-of-custody record.

**5.3 Custody Seals**

Two custody seals must be placed on opposite corners of all shipping containers (e.g., cooler) before shipment. The seals shall be signed and dated by the shipper.

Custody seals may also be required to be placed on individual sample bottles. Check with the client or refer to EPA regional guidelines for direction. In these instances the custody seal is placed over or in some cases around the lid or cap of the sample container.

**5.4 Sample Shipping**

SOP 2-1, *Packaging and Shipping Environmental Samples* defines the requirements for packaging and shipping environmental samples.

**6.0 Restrictions/Limitations**

Check with the EPA region or client for specific guidelines. If no specific guidelines are identified, this procedure shall be followed.

For EPA CLP sampling events, combined chain-of-custody/traffic report forms generated with Scribe or other EPA-specific records may be used. Refer to regional guidelines for completing these forms.

The EPA Scribe software may be used to customize sample labels and custody records when directed by the client or the CDM Smith project manager.

**Sample Custody**

SOP 1-2  
Revision: 8  
Date: February 2015

**7.0 References**

U. S. Army Corps of Engineers. 2001 or current revision. *Requirements for the Preparation of Sampling and Analysis Plan*, EM 200-1-3. Appendix F. February.

U. S. Environmental Protection Agency. Revised March 1992 or current revision. *National Enforcement Investigations Center, Multi-Media Investigation Manual*, EPA-330/9-89-003-R. p.85.

\_\_\_\_\_. 2015. Scribe Manuals. [http://www.ertsupport.org/scribe\\_home.htm](http://www.ertsupport.org/scribe_home.htm) and <http://www.epaosc.org/scribe>

\_\_\_\_\_. 2002 or current revision. *EPA Guidance for Quality Assurance Project Plans*, EPA QA/G-5, EPA/240/R-02/009. Section 2.2.3. December.

\_\_\_\_\_. 2014 or current revision. *Sampler's Guide, Contract Laboratory Program Guidance for Field Samplers*, EPA-540-R-09-03. January.

**Sample Custody**

SOP 1-2  
 Revision: 8  
 Date: February 2015

**Figure 1**  
**Example CDM Smith Chain-of-Custody Record**

125 Maiden Lane, 5th Floor  
 New York, NY 10038  
 (212) 785-9123  
 Fax: (212) 785-6114

**CHAIN OF CUSTODY RECORD**

|  |                          |  |            |  |           |   |           |              |                          |
|--|--------------------------|--|------------|--|-----------|---|-----------|--------------|--------------------------|
| PROJECT ID.  |                          | FIELD TEAM LEADER  |            | LABORATORY AND ADDRESS                   |           |   |           | DATE SHIPPED |                          |
| PROJECT NAME/LOCATION  |                          |  |            | LAB CONTRACT:                            |           |   |           | AIRBILL NO.  |                          |
| MEDIA TYPE<br>1. Surface Water<br>2. Groundwater<br>3. Leachate<br>4. Field QC<br>5. Soil/Sediment<br>6. Oil<br>7. Waste<br>8. Other _____ |                          | PRESERVATIVES<br>1. HCl, pH <2<br>2. HNO <sub>3</sub> , pH <2<br>3. NaOH, pH >12<br>4. H <sub>2</sub> SO <sub>4</sub> , pH <2<br>5. Zinc Acetate, pH >9<br>6. Ice Only<br>7. Not Preserved<br>8. Other _____ |            | SAMPLE TYPE<br>G = Grab<br>C = Composite |           | ANALYSES (List no. of containers submitted) |           |              |                          |
| SAMPLER SIGNATURES:  |                          |  |            |  |           |   |           |              |                          |
| SAMPLE LOCATION NO.  | LABORATORY SAMPLE NUMBER | PRESERVATIVES ADDED  | MEDIA TYPE | SAMPLE TYPE                              | 20__ DATE | TIME SAMPLED                                |           |              | REMARKS (Note if MS/MSD) |
| 1.   |                          |  |            |  |           |   |           |              |                          |
| 2.   |                          |  |            |  |           |   |           |              |                          |
| 3.   |                          |  |            |  |           |   |           |              |                          |
| 4.   |                          |  |            |  |           |   |           |              |                          |
| 5.   |                          |  |            |  |           |   |           |              |                          |
| 6.   |                          |  |            |  |           |   |           |              |                          |
| 7.   |                          |  |            |  |           |   |           |              |                          |
| 8.   |                          |  |            |  |           |   |           |              |                          |
| 9.   |                          |  |            |  |           |   |           |              |                          |
| 10.  |                          |  |            |  |           |   |           |              |                          |
| RELINQUISHED BY: (PRINT)   | DATE/TIME                | RECEIVED BY: (PRINT)   | DATE/TIME  | RELINQUISHED BY: (PRINT)                 | DATE/TIME | RECEIVED BY: (PRINT)                        | DATE/TIME |              |                          |
| (SIGN)   |                          | (SIGN)   |            | (SIGN)                                   |           | (SIGN)                                      |           |              |                          |
| RELINQUISHED BY: (PRINT)   | DATE/TIME                | RECEIVED BY: (PRINT)   | DATE/TIME  | RELINQUISHED BY: (PRINT)                 | DATE/TIME | RECEIVED BY: (PRINT)                        | DATE/TIME |              |                          |
| (SIGN)   |                          | (SIGN)   |            | (SIGN)                                   |           | (SIGN)                                      |           |              |                          |
| COMMENTS:  |                          |  |            |  |           |   |           |              |                          |

DISTRIBUTION: White and yellow copies accompany sample shipment to laboratory; yellow copy retained by laboratory; Pink copy retained by samplers.

1/98

**Note:** If requested by the client, different chain-of-custody records may be used. Copies of the template for this record may be obtained from the Chantilly Graphics Department.

Sample Custody

SOP 1-2  
 Revision: 8  
 Date: February 2015

Figure 2  
 Example Sample Tag

|                     |                  |   |   |                  |  |
|---------------------|------------------|---|---|------------------|--|
| Designate           | Grab             | Station Location<br>Samplers (Signatures) | Preservative:<br>Yes <input type="checkbox"/> No <input type="checkbox"/> |                  |  |
|                     | Comp.            |   | ANALYSES  |                  |  |
| Time                | Station Location |   | BOD   | Anions           |  |
|                     |                  |   | Solids  | (TSS) (TDS) (SS) |  |
| COD, TOC, Nutrients |                  |   |   |                  |  |
| Phenolics           |                  |   |   |                  |  |
| Mercury             |                  |   |   |                  |  |
| Metals              |                  |   |   |                  |  |
| Cyanide             |                  |   |   |                  |  |
| Oil and Grease      |                  |   |   |                  |  |
| Organics GC/MS      |                  |   |   |                  |  |
| Priority Pollutants |                  |   |   |                  |  |
| Volatile Organics   |                  |   |   |                  |  |
| Pesticides          |                  |   |   |                  |  |
| Mutagenicity        |                  |   |   |                  |  |
| Bacteriology        |                  |   |   |                  |  |
| Month/Day/Year      |                  | Remarks:                                  |   |                  |  |
| Station No.         |                  |   |   |                  |  |
| Project Code        |                  |   |   |                  |  |
|                     |                  | Tag No.                                   | Lab Sample No.  |                  |  |
|                     |                  | 3-3023215                                 |   |                  |  |

**Note:** Equivalent sample labels or tags may be used.

**Surface Soil Sampling**

SOP 1-3

Revision: 9

Date: February 2015

Approved:

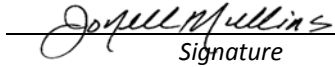
  
Signature

Technical Review:

Mike Valentino

**1.0 Objective**

The purpose of this technical standard operating procedure (SOP) is to define the general techniques and requirements for the collection of surface soil samples.

**2.0 Background**

The techniques and protocols described herein may be used to collect other surface media, including sediment and sludge.

**2.1 Definitions**

**Grab Sample** - A discrete portion of sample material or an aliquot taken from a specific sample location at a given point in time.

**Spoon/Scoop** - A small stainless steel, Teflon<sup>®</sup>, or Teflon<sup>®</sup>-lined utensil measuring approximately 15 cm (6 inches) in length with a stem-like handle (for manual operation). Samples are collected using a scooping action.

**Surface Soil** - Soils generally defined as the soils extending from ground surface to approximately 30 centimeters (cm), or approximately one foot, below ground surface (bgs). Surface soil samples are frequently collected from 0 to 15 cm (0 to 6 inches) bgs. Depending on the soil interval sampled will vary.

**Syringe** - A hand-held, T-shaped, disposable plastic sampling device used to obtain undisturbed, unconsolidated material samples (e.g., soil or sediment) for laboratory analyses. Samples are collected by pushing the open end of the sampling device into the material to be sampled to retrieve a discrete sample, typically in the amount of 5 or 10 grams.

**Trowel** - A small stainless steel or Teflon or Teflon<sup>®</sup>-lined shovel measuring approximately 15 to 20 cm (6 to 8 inches) in length with a slight (approximately 140°) curve across the length. The trowel has a stem-like handle (for manual operation). Samples are collected with a scooping action.

**2.2 Associated Procedures**

- SOP 1-2, *Sample Custody*
- SOP 2-1, *Packaging and Shipping Environmental Samples*
- SOP 4-1, *Field Logbook Content and Control*
- SOP 4-5, *Field Equipment Decontamination at Nonradioactive Sites*

**2.3 Discussion**

Surface soil samples are collected to determine the type(s) and level(s) of contamination in soil and often provide information important to the completion of risk assessments for a given site. Surface soil samples may be collected as part of a site investigation or as part of a site-specific sampling plan, and/or as a screen for "hot spots", which may require more extensive sampling based on the results of the initial surface soil sampling.

Sediment(s) and sludge(s) that have been exposed by evaporation, stream rerouting, or any other means are collected by the same methods as those for surface soil(s). Typically the top 1 to 2 cm of material are carefully removed before collection of the sample. If a thick, matted root zone is encountered at or near the surface, it shall be removed before collecting the representative soil sample. Surface soil, exposed sediment, or sludge is collected using stainless steel and/or Teflon-lined trowels or scoops.

**3.0 General Responsibilities**

**Site Manager** - The site manager is responsible for ensuring that sampling efforts are conducted in accordance with this procedure and any other SOPs pertaining to the sampling of specific media. The site manager must also ensure that the quantity and location of surface soil samples collected meet the requirements of the site-specific sampling plan.



## Surface Soil Sampling

SOP 1-3

Revision: 9

Date: February 2015

**Field Team Leader** - The field team leader is responsible for ensuring that field personnel collect surface soil samples in accordance with this SOP and other relevant guidance for surface soil sampling.

**Note:** Responsibilities may vary from site to site. Therefore, all field team member responsibilities shall be defined in the field plan or site/quality assurance project plan (QAPP).

### 4.0 Required Equipment

- Insulated cooler and clear waterproof sealing tape
- Securely-sealed bags of ice or “blue ice” packs
- Nitrile or other appropriate protective gloves
- Plastic zip-top bags
- Personal protective clothing and equipment
- Stainless steel and/or Teflon-lined spatulas and pans, trays, or bowls
- Plastic sheeting (disposable, protective ground cover)
- Stainless steel and/or Teflon-lined trowels or spoons/scoops (or other equipment as specified in the site-specific sampling plan)
- Appropriate project documents (including sampling or work plan, and health and safety plan)
- Appropriate sample containers
- Field logbook
- Indelible black ink pen and/or marker
- Sample chain-of-custody forms
- Custody seals
- Decontamination supplies
- Paper towels or Kimwipes

Additional equipment is discussed in Section 5.2.2, VOC Field Sampling/Preservation Methods.

## 5.0 Procedures

### 5.1 Preparation

The following steps must be followed when preparing for sample collection:

1. Review site-specific health and safety plan and project plans before initiating sampling activity.
2. Don the appropriate personal protective clothing as specified in the site-specific health and safety plan.
3. Locate sampling location(s) in accordance with project documents (e.g., work plan) and document pertinent information in the field logbook. When possible, reference sampling locations back to known, existing site features such as buildings, roads, intersections, etc.
4. Processes for verifying sample collection depth must be specified in the site-specific sampling or work plans.
5. Place clean plastic sheeting on a flat, level surface near the sampling area, if possible, and place sampling equipment on the plastic; place the insulated cooler(s) on separate plastic sheeting to avoid the potential for any cross-contamination.
6. A clean, new or sufficiently decontaminated trowel, scoop, or spoon will be used to obtain sample material from each specified sample location. Other equipment may be used (e.g., shovels) to collect sample material if constructed of stainless steel and decontaminated appropriately prior to use.

### 5.2 Sample Collection

The following general steps must be followed when collecting surface soil samples.

1. Wear new, clean gloves during handling of all sample containers and sampling devices. Change out gloves at each sampling location, or each time a new sample is to be collected, to avoid cross-contamination.
2. Surface soil samples are typically collected from the areas of least contamination to the areas of the greatest contamination, if known.

**Surface Soil Sampling**

SOP 1-3

Revision: 9

Date: February 2015

3. Document the sampling process by recording applicable information in the designated field logbook. Document any and all deviations from SOPs and the sampling plan in the field logbook and include rationale for changes. See SOP 4-1 for guidance on entering information into field log books.
4. During sample collection, record observations made of the geologic features of the soil or sediments per American Society for Testing and Materials (ASTM) D 2448 (Standard Practice for Description and Identification of Soils (Visual-Manual Procedure) in the field logbook.
5. Carefully remove stones, vegetation, snow, etc. from the ground surface in the sampling location area. Clear the sample location using a new and/or appropriately decontaminated spoon, scoop, or other tool as described to expose a fresh sampling surface.
6. Collect the required sample aliquot for volatile analyses, as appropriate, as well as any other samples that may be degraded by aeration, followed by the collection of samples for other analyses. Note that samples are typically not collected from ground surface to approximately six (6) to twelve (12) inches below ground surface for volatile organic compound analysis because of the potential for volatile loss. Sample collection and preservation techniques, as appropriate, are discussed in the following subsections of this SOP.
7. Store samples at 4° Celsius (C) ( $\pm 2^{\circ}\text{C}$ ) until samples are delivered to the designated analytical laboratory. An appropriate amount of ice or number of cold packs should be used according to the number of samples and/or the volume of sample material collected in order to ensure that a temperature of 4°C is achieved and maintained for delivery to the analytical laboratory. Sample holding times shall be determined with the appropriate analytical laboratory.
8. Pack all samples as required by the work plan and/or laboratory requirements. Include properly completed documentation and affix signed and dated custody seals to the cooler lid. See SOPs 1-2 and 2-1 for guidance on sample custody procedures and packaging and shipping environmental samples.
9. Decontaminate sampling equipment between sample locations. See SOP 4-5 for guidance on decontamination of field equipment at non-radioactive sites.

**5.2.1 Method for Collecting Samples for Nonvolatile Organic or Inorganic Compound Analysis**

The requirements for collecting samples of surface soil for nonvolatile organic or inorganic analyses are as follows:

1. Wear new, clean gloves during handling of all sample containers and sampling devices. Change out gloves at each sampling location, or each time a new sample is to be collected, to avoid cross-contamination.
2. Clear the area to be sampled of debris as described in Section 5.2 of this SOP. Determine sample depth as described in the sampling plan.
3. Label each sample container with the appropriate sample collection information.
4. Use a decontaminated stainless steel or Teflon-lined trowel or spoon to obtain sufficient sample material from the required interval and subsampling points, if necessary, to fill the specified sample containers.
5. Empty the contents of the sampling device directly into a clean stainless steel or Teflon-lined tray or bowl.
6. Homogenize the sample by mixing with a spoon, spatula, or trowel.
7. Use the spoon, spatula, or trowel to distribute the mixture into the labeled sample containers. Fill organic sample containers first, then inorganic sample containers.

**Surface Soil Sampling**

SOP 1-3

Revision: 9

Date: February 2015

8. Secure the respective cap on each sample container immediately after filling.
9. Wipe the sample containers with a clean paper towel or Kimwipe to remove any residual soil from the sample container surface.
10. Place sample containers in individual zip-top plastic bags and seal the bags.
11. Store samples at 4° C ( $\pm 2^{\circ}\text{C}$ ) until samples are delivered to the designated analytical laboratory
12. Pack all samples as required by the work plan and/or laboratory requirements. Include properly completed documentation and affix signed and dated custody seals to the cooler lid. See SOPs 1-2 and 2-1 for guidance on sample custody procedures and packaging and shipping environmental samples.
13. Decontaminate all non-disposable sampling equipment in accordance with SOP 4-5.

**5.2.2 Method for Collecting Soil Samples for Volatile Organic Compound Analysis**

The requirements for collecting grab samples of surface soil for volatile organic compounds (VOCs) or other samples degraded by aeration are as follows:

1. VOC samples shall be collected with the least disturbance to the soil as possible. When grab sampling for VOC analysis or for analysis of any other compound(s) that may be degraded by aeration, it is necessary to minimize sample disturbance and consequently minimize analyte loss. The representativeness of a VOC grab sample is difficult to determine because the collected sample represents a single point, is not homogenized, and has been disturbed.
2. VOC samples shall be collected as grab samples as discussed in section 5.2.2 of this SOP. Although the method of collection may vary from site to site based on data quality objectives and the degree of known or suspected contamination, collection of samples for VOC analysis should follow the sampling and preservation methodology as described below.
3. Complete the sample label by filling in the appropriate information (e.g., sample identification, date and time of sample collection, and requested analyses) and securing the label to the container.
4. Use a clean stainless steel or Teflon-lined trowel or spoon/scoop to collect sufficient material in one grab to fill the sample containers.
5. With the aid of a clean stainless steel spatula, quickly fill the sample containers directly from the sampling device, removing stones, twigs, grass, etc., from the sample material, as needed. Fill the sample containers, compacting the sample material as much as possible to minimize headspace in each of the containers.
6. Immediately secure the Teflon-lined cap(s) on the sample container(s).
7. Wipe the containers with a clean Kimwipe or paper towel to remove any residual soil from the exterior of the container.
8. Place the sample containers in individual zip-top plastic bag(s) and seal the bag(s).
9. Store samples at 4° Celsius (C) ( $\pm 2^{\circ}\text{C}$ ) until samples are delivered to the designated analytical laboratory. Determine sample holding times with the appropriate analytical laboratory.
10. Pack all samples as required by the work plan and/or laboratory requirements. Include properly completed documentation and affix signed and dated custody seals to the cooler lid. See SOPs 1-2 and 2-1 for guidance on sample custody procedures and packaging and shipping environmental samples.
11. Decontaminate all non-disposable sampling equipment in accordance with SOP 4-5.

**Surface Soil Sampling**

SOP 1-3

Revision: 9

Date: February 2015

**Note:** A trip blank shall be included with sample coolers containing VOC samples. QC sample requirements vary from project to project. Consult the project-specific sampling plan for requirements.

**5.2.3 VOC Field Sampling/Preservation Methods**

The following four sections contain SW-846 test methods for sampling and field preservation of soil samples for VOC analysis. These methods include the EnCore™ Sampler Method for low-level VOC analyses, EnCore Sampler Method for high-level VOC analyses, acid preservation for low-level VOC analyses, and methanol preservation for high-level VOC analyses. Equipment requirements in addition to the equipment specified in Section 4.0 of this SOP for each method are indicated at the beginning of each subsection as follows

When collecting soil samples using the EnCore Sampler Method, collection of soil for moisture content analysis is required. Results of the moisture analysis are used to adjust “wet” concentration results to “dry” concentrations to meet analytical method requirements.

**Note:** Some variation from these methods may be required depending on the contracted analytical laboratory. For example, sample volume requirements are general requirements. Actual sample volumes, sizes, and quantities may vary depending on client or laboratory requirements.

**5.2.3.1 EnCore Sampling Equipment and Collection for Low Level VOC Analyses (<200 µg/kg)**

The following equipment is required for low-level analysis:

- Three new 5-gram (g) EnCore samplers
- One 110-milliliter (mL) (4-ounce) wide-mouth glass jar or applicable container for moisture analysis
- One EnCore sampler T-handle

The requirements for collecting samples for low level analysis (<200 µg/kg) of VOCs by the EnCore Sampler Method are as follows:

1. Wear new, clean gloves during handling of all sample containers and sampling devices. Change out gloves at each sampling location, or each time a new sample is to be collected, to avoid cross-contamination.
2. Clear the area to be sampled of debris as described in Section 5.2 of this SOP. Determine sample depth as described in the sampling plan.
3. Remove EnCore sampler and cap from package and attach T-handle to sampler body.
4. Push the sampler into the freshly-exposed sampling surface until the O-ring is visible within the hole on the side of the T-handle. If the O-ring is not visible within this window, then the sampler is not full.
5. Extract the sampler and wipe the sampler head with a clean paper towel or Kimwipe so that the sampler cap can be tightly attached.
6. Push the sampler cap on the head of the sampler with a twisting motion to secure it to the sampler body.
7. Rotate the sampler stem counterclockwise until the stem locks in place to retain the sample within the sampler body.
8. Fill out the sample label with the appropriate sample information (e.g., sample identification, date/time of sample collection, requested analyses) and attach to sampler.
9. Repeat procedure for each of the remaining two samplers.
10. Collect a representative moisture sample in a 110 milliliter (mL) (4-ounce) wide-mouth jar using a new or clean Teflon-lined stainless steel spoon, scoop, or trowel.

**Surface Soil Sampling**

SOP 1-3

Revision: 9

Date: February 2015

11. Store samples at 4° C ( $\pm 2^{\circ}\text{C}$ ) until samples are delivered to the designated analytical laboratory. Samples must be shipped and delivered to the analytical laboratory for extraction within 48 hours.
12. Pack all samples as required by the work plan and/or laboratory requirements. Include properly completed documentation and affix signed and dated custody seals to the cooler lid. See SOPs 1-2 and 2-1 for guidance on sample custody procedures and packaging and shipping environmental samples.
13. Decontaminate all non-disposable sampling equipment in accordance with SOP 4-5.

**Note:** Verify analytical laboratory requirements for extraction/holding times.

#### **5.2.3.2 Acid Preservation Equipment and Sampling Requirements for Low Level VOC Analyses (<200 $\mu\text{g}/\text{kg}$ )**

**Note:** Although not common, acid preservation may be required and should only be performed if specified in the project specific sampling plans. If required, determine the specific field acid preservation procedure based on the requirements specified in the analytical method to be employed. Variations between analytical methods exist with respect to field acid preservation.

The following equipment and supplies are required if field acid preservation is required:

- One 40-mL VOA vial with acid preservation (for field testing of soil pH)
- Two preweighed 40-mL VOA vials with acid preservative and stir bar (for lab analysis)
- Two preweighed 40-mL VOA vials with water and stir bar (in case samples cannot be pre-preserved)
- One pre-weighed jar containing methanol or a pre-weighed empty jar accompanied by a pre-weighed VOA vial containing methanol (for sample screening and/or high level VOC analysis)
- One 110-mL (4-oz) wide-mouth glass jar or other container appropriate for retaining a representative sample for moisture analysis
- One 55-mL (2-oz) jar containing acid preservative (additional acid may be needed because of high soil pH)
- One appropriately sized, non-reactive scoop or measuring spoon capable of delivering 1 g of solid sodium bisulfate
- pH paper
- Weighing scale capable of reading to 0.01 g
- Set of balance weights used in daily balance calibration
- Sodium bisulfate acid solution ( $\text{NaHSO}_4$ )
- A plastic syringe or other sampling device capable of collecting a sufficient sample volume of approximately 5 g

#### **Testing Effervescing Capacity of Soils**

Soils must be tested with acid to determine the amount of effervescing that will occur when preserved with acid. Effervescing will drive off VOCs as well as create a high pressure in a sealed VOA vial that could result in the explosion of the sample container. The following steps provide information on the effervescing capacity of the soil.

1. Wear new, clean gloves during handling of all sample containers and sampling devices. Change out gloves at each sampling location, or each time a new sample is to be collected, to avoid cross-contamination.
2. Clear the area to be sampled of debris as described in Section 5.2 of this SOP. Determine sample depth as described in the sampling plan.
3. Using a new, clean syringe, place approximately 5 g of soil into a VOA vial that contains acid preservative and no stir bar.
4. Do not cap this vial as it may EXPLODE upon interaction with the soil.
5. Observe the sample for gas formation, or effervescence (bubbles that form due to the interaction of carbonates in the soil with the acid preservative).

**Surface Soil Sampling**

SOP 1-3

Revision: 9

Date: February 2015

6. If vigorous or sustained effervescence is observed, then acid is not an acceptable preservative for the sample.
  - In this case the samples need to be collected in the VOA vials containing only water as a preservative and a stir bar. The vials with acid preservative CANNOT be used.
7. If a small amount or no effervescence occurs, then acid is acceptable to preserve the sample. Keep this initial testing VOA vial for use in the buffering test as detailed below.
  - In this case the samples need to be collected in the VOA vials containing acid preservative and a stir bar.

**Testing Buffering Capacity of Soils**

The soils must be tested to determine the quantity of acid that is required to achieve a pH reading of  $\leq 2$  standard units (SUs). The following steps will assist in determining this quantity.

1. If acid preservation is acceptable for sampling soils, then the sample vial that was used to test the effervescing capacity of the soils can be used to test the buffering capacity.
2. Wear new, clean gloves during handling of all sample containers and sampling devices. Change out gloves at each sampling location, or each time a new sample is to be collected, to avoid cross-contamination.
3. Clear the area to be sampled of debris as described in Section 5.2 of this SOP. Determine sample depth as described in the sampling plan.
4. Cap the VOA vial containing the 5 g of soil, acid preservative, and no stir bar as retained during Step 7 of the effervescing test as described above.
5. Shake the VOA vial gently to homogenize the contents.
6. Open the VOA vial and test the pH of the acid solution with pH paper by dipping one end of a pH paper strip into the soil/acid solution.
  - If the pH paper indicates a pH below 2, then samples can be collected in the two preweighed 40-mL VOA vials with the acid preservative and stir bar. As the pH reading is below 2, it is not necessary to add additional acid to the VOA vials.
  - If the pH paper indicates a pH above 2, then additional acid needs to be added to the VOA vial.
7. To add acid to a sample with a pH above 2, measure out 1 g of the solid sodium bisulfate acid and add to the appropriate VOA vial.
8. Cap the VOA vial and shake thoroughly.
9. After an additional 1 g of solid sodium bisulfate has been added to the VOA vial containing sample material with a pH above 2, repeat Step 4.
  - If the pH paper reads below 2, then the samples can be collected in the two preweighed 40-mL VOA vials containing acid preservative, a stir bar, and 1 g of sodium bisulfate.
  - On the Chain of Custody and in the field log book, note that one additional gram of acid was added such that the laboratory can analyze the samples accordingly.
  - If the pH paper reads above 2, repeat Steps 5 through 7 until the sample pH is less than or equal to 2 SUs.

After the soil chemistry has been determined, samples can be collected. The procedure summarized below assumes the appropriate acid- or water-preserved VOA vials are used based on the guidance discussed.

**Sample Preservation Steps**

1. Wear new, clean gloves during handling of all sample containers and sampling devices. Change out gloves at each sampling location, or each time a new sample is to be collected, to avoid cross-contamination.

**Surface Soil Sampling**

SOP 1-3

Revision: 9

Date: February 2015

2. Add more acid to the sample if necessary (based on the buffering capacity testing discussed in the previous section).
3. Collect an approximately 5-g soil sample using a cutoff plastic syringe or other sampling device designed to obtain 5 g of soil from a freshly exposed sampling surface.
4. Carefully wipe exterior of sample collection device with a clean paper towel or Kimwipe.
5. Transfer the sample from the sample collection device to the appropriate VOA vial, using caution when extruding the sample to prevent splashing the acid outside of the vial.
6. Remove any soil from the threads of the VOA vial using a clean paper towel or Kimwipe.
7. Cap the VOA vial and weigh the jar to the nearest 0.01 g.
8. Record the exact weight on the sample label.
9. Repeat this sampling procedure for the duplicate VOA vial.
10. Weigh the VOA vial containing methanol preservative to the nearest 0.01 g. If the weight of the vial with methanol varies by more than 0.01 g from the original weight recorded on the vial, discard the vial. If the weight is within tolerance, it can be used for soil preservation as discussed below.
11. Take a clean, empty sample jar or the jar that contains the methanol preservative and collect a 5-g or 25-g sample using a cutoff plastic syringe or other coring device designed to deliver 5 g or 25 g of soil from a freshly exposed sample surface. The 5-g or 25-g size is dependent on the client or analytical laboratory requirements, or as specified in the sampling plan.
12. Carefully wipe the exterior of the collection device with a clean paper towel or Kimwipe.
13. Transfer the soil to a clean, empty jar or a VOA vial that contains methanol. If extruding into a jar that contains methanol, be careful not to splash the methanol outside of the sample container.
14. If the jar used to collect the soil sample did not contain preservative before the soil was added, immediately preserve with the methanol provided, using only one vial of methanol preservative per sample jar.
15. Remove any soil from the threads of the VOA vial using a clean paper towel or Kimwipe and cap the vial.
16. Weigh the jar with sample to the nearest 0.01 g and record the weight on the sample label.
17. Collect dry weight sample using a clean stainless steel spoon or trowel.
18. Store samples at 4°C ( $\pm 2^\circ\text{C}$ ) until samples are delivered to the designated analytical laboratory
19. Pack all samples as required by the work plan and/or laboratory requirements. Include properly completed documentation and affix signed and dated custody seals to the cooler lid. See SOPs 1-2 and 2-1 for guidance on sample custody procedures and packaging and shipping environmental samples.
20. Decontaminate all non-disposable sampling equipment in accordance with SOP 4-5.

**Surface Soil Sampling**

SOP 1-3

Revision: 9

Date: February 2015

**5.2.3.3 EnCore Sampling Equipment and Sampling Requirements for High Level Analysis ( $\geq 200 \mu\text{g}/\text{kg}$ )**

The following equipment is required for high-level analysis:

- One 5-g sampler or one 25-g sampler

**Note:** The volume requirements specified are general requirements. Actual sample volumes, container sizes, and quantities may vary depending on client or laboratory requirements.

- One 110-mL (4-oz) wide-mouth glass jar or applicable container specified for moisture analysis
- One T-handle EnCore sampler

The requirements for collecting high level analysis by the EnCore Sampler Method are as follows:

1. Wear new, clean gloves during handling of all sample containers and sampling devices. Change out gloves at each sampling location, or each time a new sample is to be collected, to avoid cross-contamination.
2. Clear the area to be sampled of debris as described in Section 5.2 of this SOP. Determine sample depth as described in the sampling plan.
3. Remove the EnCore sampler and cap from package and attach the T-handle to sampler body.
4. Push the sampler into freshly exposed soil surface until the O-ring is visible within the hole/window on the side of the T-handle. If the O-ring is not visible within the window/hole, then the sampler is not full.
5. Use a clean paper towel or Kimwipe to wipe the sampler head so that the cap can be tightly attached.
6. Push the sampler cap on the sampler head with a twisting motion to secure it to the sampler body.
7. Fill out the sample label and attach it to sampler.
8. Rotate the sampler stem counterclockwise until the stem locks in place to retain the sample within the sampler body.
9. Collect a representative moisture sample in 110-mL (4-oz) wide-mouth glass jar or designated container using a clean stainless steel spoon or trowel.
10. Store samplers at 4°C ( $\pm 2^\circ\text{C}$ ) until samples are delivered to the designated analytical laboratory. Samples must be shipped and delivered to the analytical laboratory for extraction within 48 hours.
11. Pack all samples as required by the work plan and/or laboratory requirements. Include properly completed documentation and affix signed and dated custody seals to the cooler lid. See SOPs 1-2 and 2-1 for guidance on sample custody procedures and packaging and shipping environmental samples.
12. Decontaminate all non-disposable sampling equipment in accordance with SOP 4-5.

**Note:** Verify requirements for extraction/holding times.

**5.2.3.4 Methanol Preservation Equipment and Sampling Requirements for High Level Analyses ( $\geq 200 \mu\text{g}/\text{kg}$ )**

The following equipment is required for high-level analysis:

- One pre-weighed jar that contains methanol or a pre-weighed empty jar accompanied by a pre-weighed VOA jar that contains methanol (laboratory grade)
- Cutoff plastic syringe or other sampling device to obtain 5 g or 25 g of soil
- Set of balance weights used in daily balance calibration
- One dry weight cup
- Weighing balance that accurately weighs to 0.01 g



**Surface Soil Sampling**

SOP 1-3

Revision: 9

Date: February 2015

The requirements for sampling and preservation are as follows:

1. Wear new, clean gloves during handling of all sample containers and sampling devices. Change out gloves at each sampling location, or each time a new sample is to be collected, to avoid cross-contamination.
2. Clear the area to be sampled of debris as described in Section 5.2 of this SOP. Determine sample depth as described in the sampling plan.
3. Weigh the VOA vial containing methanol preservative to the nearest 0.01 g. If the weight of the VOA vial containing methanol varies by more than 0.01 g from the original weight recorded on the vial, discard the vial. If the weight is within tolerance, it can be used for soil preservation/collection as described below. (Commercial sources are available which supply pre-preserved and tared vials which eliminates the need to transport and handle larger quantities of methanol and eliminates the need for a precision scale vials with preservative).
4. Quickly collect a 5-g or 25-g sample using a plastic syringe or other sampling device designed to obtain 5 g or 25 g of soil from a freshly exposed sampling surface.
5. Carefully wipe the exterior of the collection device with a clean paper towel or Kimwipe.
6. Quickly transfer the soil to an empty jar or a jar that contains methanol. If extruding into a jar that contains methanol, be careful not to splash the methanol outside of the vial. The type of jar used and the sample volume needed is dependent on the client or laboratory requirements.
7. If the jar used to collect the soil sample was empty before the soil was added, immediately preserve with the methanol provided, using only one vial of methanol preservative per sample jar.
8. Remove any soil from the exterior of the vial using a clean paper towel or Kimwipe and cap the sample container.
9. Weigh the jar containing the soil to the nearest 0.01 g and record the weight on the sample label.
10. Collect a dry weight sample in a clean, unpreserved sample container using a clean stainless steel spoon or trowel.
11. Store samples at 4°C ( $\pm 2^\circ\text{C}$ ) until samples are delivered to the designated analytical laboratory.
12. Pack all samples as required by the work plan and/or laboratory requirements. Include properly completed documentation and affix signed and dated custody seals to the cooler lid. See SOPs 1-2 and 2-1 for guidance on sample custody procedures and packaging and shipping environmental samples.
13. Decontaminate all non-disposable sampling equipment in accordance with SOP 4-5.
14. If dropping the samples off at the analytical laboratory or requesting a sample pick-up is not an option, sample containers may need to be shipped to the analytical laboratory. Samples should be packed with ice packs sufficient to maintain a temperature of 4°C in the cooler, and shall be shipped in accordance with Department of Transportation (DOT) regulations. Consult CDM Smith's Health and Safety website ([http://cdmweblegacy/h&s/hazmat\\_transport.html](http://cdmweblegacy/h&s/hazmat_transport.html)) for guidance on shipping hazardous materials.

**6.0 Restrictions/Limitations**

As presented in Section 5.2 of this SOP, when grab sampling for VOC analysis or for analysis of any other compound(s) that may be degraded by aeration, it is necessary to minimize sample disturbance and consequently minimize analyte loss. The representativeness of a VOC grab sample is difficult to determine because the collected sample represents a single point, is not homogenized, and has been disturbed.

**Surface Soil Sampling**

SOP 1-3  
Revision: 9  
Date: February 2015

**7.0 References**

U. S. Environmental Protection Agency. *A Compendium of Superfund Field Operations Methods*, EPA/540/P-87/001. December 1987 or current revision.

\_\_\_\_\_. *Test Methods for Evaluating Solid Waste, Physical/Chemical Methods (SW-846)*, Third Edition, November 1986, (as amended by Updates I, II, IIA, IIB, III, and IIIA, IIIB, and IVA, IVB). Method 5035 (**Note**: § 6.2.1.8 of this method says samples stored in EnCore™ samplers shall be analyzed within 48 hours or transferred to soil sample vials in the laboratory within 48 hours): December 1996, Revision O, Closed-System Purge-and-Trap and Extraction for Volatile Organics in Soil and Waste Samples.

\_\_\_\_\_. 2014. Region 4. *The Field Branches Quality System and Technical Procedures, Soil Sampling. SESDPROC-300-R3*. August.

**Subsurface Soil Sampling**

SOP 1-4

Revision: 8

Date: February 2015

Approved:

  
Signature

Technical Review:

David Schroeder

**1.0 Objective**

The objective of this technical standard operating procedure (SOP) is to define the techniques and requirements for collecting soil samples for environmental or geotechnical characterization purposes from the unconsolidated subsurface zone. General techniques discussed in this SOP include use of hand augers, split-barrel samplers, Shelby tubes, direct-push rig samplers, and backhoes, as well as field sampling and preservation methods.

**2.0 Background****2.1 Definitions**

**Auger Flight** - A steel section length attached to the auger length to extend the augers and remove additional unconsolidated material as drilling depth increases.

**Backhoe** - An excavator to which a shovel bucket is attached to a hinged boom and is drawn backward to move materials.

**Direct Push Rig Sampler** - A sampler with a locking tip that keeps the device closed during the sampling push. The tip is released at the desired depth, and the push is continued. During the push, the soil is pushed up into the sampler.

**Grab Sample** - A discrete portion or aliquot of material taken from a specific location at a given point in time.

**Hand Auger** - A stainless steel cylinder (bucket) approximately 7 to 10 centimeters (cm), or 3 to 4 inches (in) in diameter and 30 cm, or 1 foot (ft) in length, open at both ends with the bottom edge designed to advance perpendicular to the ground surface with a twisting motion into unconsolidated subsurface material to obtain a soil sample. The auger has a T-shaped handle (used for manual operation) attached to the top of the bucket by extendable stainless steel rods.

**Liner** - A cylindrical sleeve generally made of brass, stainless steel, or Teflon® that is placed inside a split-barrel sampler, direct-push rig sampler, or hand auger bucket to collect samples for Volatile Organic Compound (VOC) or other analyses or to prevent sample contamination.

**Shelby Tube** - A cylindrical sampling device which is generally made of steel, and which is driven into the subsurface soil through a hollow-stem auger using a drill rig. The tube, once retrieved, is capped on both ends. The undisturbed soil sample is extruded in the laboratory before soil analysis.

**Slide Hammer** - A device consisting of a drive weight (hammer) and a drive weight fall guide.

**Split-Barrel Sampler** - A cylindrical sampling device generally made of carbon steel that fits into a hollow-stem auger. The sampler is opened lengthwise, which allows the sample to be retrieved by “splitting” the barrel sampler. Also referred to as a split-spoon.

**Subsurface Soil** - The unconsolidated, or non-lithified, material that exists deeper than approximately 30 cm (1 foot) below the ground surface (bgs).

**Unconsolidated Zone** - A layer of non-lithified earth material (soil or sediment) that has no mineral cement or matrix binding its grains.

**2.2 Associated Procedures**

- SOP 1-2, *Sample Custody*
- SOP 1-3, *Surface Soil Sampling*

## Subsurface Soil Sampling

SOP 1-4

Revision: 8

Date: February 2015

- SOP 2-1, *Packaging and Shipping Environmental Samples*
- SOP 3-5, *Lithologic Logging*
- SOP 4-1, *Field Logbook Content and Control*
- SOP 4-5, *Field Equipment Decontamination at Nonradioactive Sites*

### 2.3 Discussion

Shallow subsurface soil samples, or those taken from depths between 0.15 cm to 3 meters (m), or between 6 in and 10 ft bgs, may be collected using hand augers. However, soil samples collected with a hand auger are commonly of poorer quality than those samples collected by split-barrel or Shelby tube samplers because the soil sample is disturbed during the augering process. Split-barrel and Shelby tube samplers are generally used during collection of soil samples using hollow-stem auger drilling methods. Barrel-type samplers may also be used to collect soil samples from hand auger borings using a slide hammer device. For environmental sampling programs, liners are used to minimize the loss of volatile organic compounds (VOCs) and to prevent sample cross-contamination. Collecting samples using a backhoe enables the collector to correlate the precise vertical and horizontal interval of the sample collected relative to adjacent, visible subsurface materials.

The size and material of sampling devices used shall be selected based on project and analytical objectives and as defined in the site-specific sampling and/or work plans. Note that operation and collection of samples via drill rig (split spoon or Shelby tubes), direct-push methods, or backhoe is typically performed by subconsultants to CDM Smith, with field oversight provided by a CDM Smith field representative (engineer, geologist, scientist, or similar) as further discussed in Section 5.2 of this SOP.

### 3.0 General Responsibilities

**Site Manager** - The site manager is responsible for ensuring that field personnel are trained in the use of this procedure and the required equipment, and for ensuring that subsurface soil samples are collected in accordance with this procedure and any other SOPs pertaining to specific media sampling. The site manager must also ensure that the quantity and location of subsurface soil samples collected meet the requirements of the site-specific sampling and/or work plans.

**Field Team Leader** - The field team leader is responsible for ensuring that field personnel collect subsurface soil samples in accordance with this SOP and other relevant procedures.

**Note:** Responsibilities may vary from site to site. Therefore, all field team member responsibilities shall be defined in the field plan or site-/project-specific quality assurance project plan (QAPP).

### 4.0 Required Equipment

#### 4.1 General

- Site-specific plans (e.g., sampling, work, health and safety)
- Field logbook
- Indelible black ink pens and markers
- Clear, waterproof tape
- Appropriate sample containers
- Labels and appropriate forms/documentation for sample shipment
- Insulated cooler(s) and waterproof sealing tape
- Bags of ice or "blue ice" packs
- Nitrile or appropriate gloves
- Plastic zip-top bags
- Personal protective clothing and equipment
- Plastic sheeting
- Stainless steel and/or Teflon-lined spatulas and pans, trays, bowls, trowels, or spoons
- Decontamination supplies
- Sample chain-of-custody forms
- Custody seals
- Kimwipes or paper towels

Additional equipment is discussed in Section 5.2.7, Field Sampling/Preservation Methods.

**Subsurface Soil Sampling**

SOP 1-4

Revision: 8

Date: February 2015

**4.2 Manual (Hand) Augering**

- T-handle
- Hand auger: flighted-, bucket-, or tube-type auger as required by the site-specific plans
- Extension rods
- Wrench(es), pliers
- Slide hammer with extension rods

**4.3 Split-Barrel and Shelby Tube Sampling**

- Drill rig equipped with a 63-kilogram (kg) (140-lb) drop hammer and sufficient hollow-stem auger flights to drill to the depths required by the site-specific work/sampling plans.
- Sufficient numbers of split-barrel samplers so that at least one sampler is always decontaminated and available for sampling. Three split-barrel samplers are generally the minimum necessary (Shelby tubes are used only once).
- Split-barrel liners (as appropriate).
- Wrench(es), hammer.

**4.4 Direct Push Rig Sampling**

- Direct push rig with sufficient probe rods to extend to sample depths required by the site-specific work/sampling plans
- Sufficient number of samplers (in case of malfunction) and appropriate liners to collect adequate number of samples
- Extension rods
- Wrench(es), pliers, other specific tools

**4.5 Backhoe Sampling**

- Backhoe with a sufficient length boom to extend to planned depths
- Sufficient number of trowels or scoops
- Extension rods
- Tape, utility knife, other specific tools as needed

**5.0 Procedures****5.1 Preparation**

1. Review site-specific health and safety plan and project plans before initiating sampling activity.
2. Don the appropriate personal protective clothing as indicated in the site-specific health and safety plan.
3. Locate sampling location(s) in accordance with project documents (e.g., work plan) and document pertinent information in the appropriate field logbook. When possible, reference locations back to existing site features such as buildings, roads, intersections, etc.
4. Processes for verifying depth of sampling must be specified in the site-specific plans.
5. Clear away vegetation and debris from the ground surface at the boring location.
6. If decontamination of equipment and/or personnel is required, set up a decontamination zone in accordance with SOP 4-5.
7. Prepare an area near the sampling location to perform sample collection activities by placing plastic sheeting on the ground, or, if required by the site-specific health and safety plan and or work/sampling plans, place plastic sheeting over the area immediately surrounding the borehole, as applicable.. Sample collection should be performed at a safe distance from all heavy equipment, or as determined by heavy equipment operator(s) and/or the CDM Smith field representative.

**Subsurface Soil Sampling**

SOP 1-4

Revision: 8

Date: February 2015

**5.2 Sample Collection**

The following general steps must be followed when collecting all subsurface soil samples. Refer to section 5.3 of this SOP and SOP 1-3 (Surface Soil Sampling) for additional guidance on field sampling and preservation methods.

1. Wear clean gloves during handling of all sample containers and sampling devices.
2. VOC samples or samples that may be degraded by aeration shall be collected first and with the least disturbance possible. When sampling for VOC analysis or for analysis of any other compound(s) that may be degraded by aeration, it is necessary to minimize sample disturbance and consequently minimize analyte loss. The representativeness of a VOC grab sample is difficult to determine because the collected sample represents a single point, is not homogenized, and has been disturbed. Sample containers containing samples for VOC analysis shall be filled completely to minimize headspace (see section 5.3 of this SOP).
3. All sampling information, including environmental and/or geotechnical soil characterization, sample depth, sample volume, and requisite geotechnical or environmental analyses shall be recorded in the field logbook and on any associated forms as specified in the site-specific sampling/work plans. Sample lithology shall be described according to SOP 3-5.
4. Specific sampling devices to be used shall be identified in the site-specific work/sampling plans and shall be recorded in the field logbook.
5. Care must be taken to prevent cross-contamination and misidentification of samples as described in subsequent subsections of this SOP.

**5.2.1 Manual (Hand) Augering**

The following steps must be followed when collecting environmental soil samples using hand-auger techniques:

1. Advance the auger to the depth specified in the site-specific sampling plan for sample collection. Place cuttings on plastic sheeting or as specified in the site-specific work/sampling plans. If possible, lay out the cuttings in stratigraphic order, or from the shallowest cuttings collected to the deepest cuttings collected.
2. During auger advancement and sample collection, record observations made of the geologic features of the soil or sediments per American Society for Testing and Materials (ASTM) D 2448 (Standard Practice for Description and Identification of Soils (Visual-Manual Procedure) in the field logbook.
3. Stop advancing the auger when the top of the specified sampling depth has been reached. If required by the site-specific sampling plan, remove the auger from the hole and decontaminate the auger or use a separate decontaminated auger, then obtain the sample.
4. Collect a grab sample for VOC analyses (or samples that may be degraded by aeration) immediately and place in sample container. Sample container(s) shall be filled completely to minimize headspace.
5. Remaining sample material for other analyses shall be homogenized before placing samples in the appropriate containers.
6. Wipe container(s) with a clean Kimwipe or paper towel to remove residual soil from the exterior of the container(s).
7. Label the sample container with the appropriate information. Secure the label by covering it with a piece of clear tape.
8. Place the containers in zip-top plastic bags and seal the bags. Pack samples in a cooler with ice or cold packs (to maintain a temperature of 4°C)

**Subsurface Soil Sampling**

SOP 1-4

Revision: 8

Date: February 2015

9. Proceed with additional sampling as required by the site-specific plans.
10. When sample collection is complete, dispose of cuttings, plastic sheeting, etc., as specified in the site-specific plans.
11. Complete the field logbook entry and other appropriate forms, being sure to record all relevant information before leaving the site.
12. Properly package all samples for shipment and complete all necessary sample shipment documentation. Remand custody of samples to the appropriate personnel. Refer to SOPs 1-2 and 2-1 and site-specific plans.

**5.2.2 Manual (Hand) Augering Using a Tube Sampler with Liner or Slide Hammer**

The following steps must be followed when collecting environmental soil samples using a hand-auger and a tube sampler with liner or slide hammer:

1. Auger to the depth required for sampling. Place cuttings on the plastic sheeting as specified in the site-specific plans. If possible, lay out the cuttings in stratigraphic order.
2. During auger advancement and sample collection, record observations made of the geologic features of the soil or sediments per ASTM D 2448 (Standard Practice for Description and Identification of Soils (Visual-Manual Procedure) in the field logbook.
3. Stop advancing the auger when the top of the specified sampling depth has been reached. If required by the site-specific sampling plan, remove the auger from the hole and decontaminate the auger per the site-specific work/sampling plan (see line item 11 below).
4. Prepare a clean, new tube sampler by installing a decontaminated liner in the auger tube.
5. Obtain the sample by driving the sample tube through the sample interval with the slide hammer. Remove the liner from the tube and immediately cover the ends with Teflon tape and cap the ends of the tube. Seal the caps with waterproof tape.
6. Wipe sealed liners with a clean Kimwipe or paper towel.
7. Label the sealed liners as required in the site-specific plans. Mark the top and bottom of the sample on the outside of the liner.
8. Place sealed liners in zip-top plastic bags and seal the bags. Pack samples in a cooler with ice or cold packs (to maintain a temperature of 4°C).
9. Proceed with additional sample collection as required by the site-specific sampling plans.
10. When sampling is complete, dispose of cuttings, plastic sheeting, etc., as specified in the site-specific work/sampling plans.
11. Decontaminate all equipment according to SOP 4-5 between each sample.
12. Complete the field logbook entry and other forms, being sure to record all relevant information before leaving the site.
13. Properly package all samples for shipment and complete all necessary sample shipment documentation. Remand custody of samples to the appropriate personnel. See SOPs 1-2 and 2-1 or site-specific plans.

**5.2.3 Split-Barrel Sampling**

**Note:** Steps 1 through 12 describe the general activities to be performed by a licensed drilling contractor, not by CDM Smith personnel.

**Subsurface Soil Sampling**

SOP 1-4

Revision: 8

Date: February 2015

The following steps must be followed when collecting split-barrel samples for environmental and/or geotechnical purposes:

1. Remove any pavement and subbase material from an area of twice the bit diameter, if necessary.
2. The drilling rig will be decontaminated at a separate location before drilling, per SOP 4-5 or the site-specific decontamination procedures.
3. Attach the hollow-stem auger with the cutting head, plug, and center rod(s) to the drill rig.
4. Begin drilling and proceed to the first designated sample depth, adding auger flights as necessary.
5. Upon reaching the designated sample depth, slightly raise the auger(s) to disengage the cutting head, and rotate the auger without advancement to clean cuttings from the bottom of the hole.
6. Remove the plug and center rods, if applicable.
7. If required by the site-specific sampling plan, install decontaminated liners in the split barrel sampler.
8. Install a decontaminated split-barrel on the center rod(s) and insert it into the hollow-stem auger. Connect the hammer assembly and lightly tap the rods to seat the drive shoe at the top of undisturbed soil or sediment.
9. Mark the center rod in 15-cm (6-inch) increments from the top of the auger(s).
10. Drive the split-barrel using the hammer. Use a full 76-cm (30-inch) drop as specified by ASTM D 1586. Record the number of blows required to drive the sampler through each 15-cm (6-inch) increment.
11. Stop driving the split-barrel sampler when the full length of the spoon (24 inches) has been driven or if refusal is encountered. Refusal occurs when little or no progress is made for 50 blows of the hammer. ASTM D1586-11 § 7.2.1 and 7.2.2 defines "refusal" as >50 blows per 6-inches advanced or a total of 100 blows.
12. Pull the sampler free by using upswings of the hammer to loosen the sampler. Pull out the center rod and sampler.
13. Unscrew the sampler assembly from the center rod and place the sampler on the plastic sheeting.
14. Remove the drive shoe and head assembly. If necessary, tap the sampler assembly with a hammer to loosen threaded couplings.
15. With the drive shoe and head assembly off, open (split) the sampler, being careful not to disturb the sample.
16. Label sample containers with appropriate information. Secure the label, covering it with a piece of clear tape. If liners were used, immediately install Teflon tape over the ends of the liners, cap the liners, and seal the caps over the ends of the liner with waterproof tape. Label the samples as required by the site-specific plans. Mark the top and bottom of each sample on the outside of each liner. Indicate boring/well number and depth on the outside of the liner, as required.
17. If samples are to be collected from the soil sample for VOC analyses and liners were not used, place sample material in the appropriate sample container immediately after opening the split-barrel, filling the sample bottle as completely as possible to minimize headspace. Seal the container immediately, then describe the sample material in the field logbook and/or associated forms per ASTM D 2488.
18. Remaining sample material shall be homogenized before placing samples in appropriate containers.
19. Record the sample identification number, depth from which the sample was taken, sample recovery and the analyses to be performed on the samples in the field logbook and on the appropriate forms.



**Subsurface Soil Sampling**

SOP 1-4

Revision: 8

Date: February 2015

20. Wipe containers with a clean Kimwipe or paper towel. Label sample containers as required when liners are not used.
21. Place containers and/or sealed liners in zip-top plastic bags and seal the bags. Pack samples in a cooler with ice or cold packs (to maintain a temperature of 4°C)
22. In the field logbook and on the boring log, describe sample lithology by observing cuttings and/or the bottom end of the liner.
23. Continue to advance the borehole to the next sampling point. Collect samples as outlined above.
24. When sampling is complete, remove the drilling rig to the heavy equipment decontamination area.
25. Dispose of cuttings, plastic sheeting, etc., as specified in the site-specific plans. Backfill borehole as specified in project- and /or site-specific work/sampling plans.
26. Decontaminate samplers and other small sampling equipment according to SOP 4-5 before proceeding to other sampling locations.
27. Complete the field logbook entry and other forms, being sure to record all relevant information before leaving the site.
28. Properly package all samples for shipment to laboratories and complete all necessary sample shipment documentation. Remand custody of the samples to appropriate personnel. See SOPs 1-2 and 2-1 or site-specific plans.

**5.2.4 Shelby Tube Sampling**

**Note:** Steps 1 through 11 describe activities to be performed by a licensed drilling contractor, not by CDM Smith personnel. ASTM D1586-11 provides additional details pertaining to this sampling methodology.

The following steps must be followed when collecting geotechnical samples using Shelby tubes:

1. Remove any pavement and subbase material from an area of twice the bit diameter, if necessary.
2. The drilling rig will be decontaminated at a separate location before drilling.
3. Attach the hollow-stem auger with the cutting head, plug, and center rod(s).
4. Begin drilling and proceed to the first designated sample depth, adding auger(s) as necessary.
5. Upon reaching the designated sample depth, slightly raise the auger(s) to disengage the cutting head, and rotate the auger without advancement to clean cuttings from the bottom of the hole.
6. Remove the plug and center rods, if applicable.
7. Attach a head assembly to a decontaminated Shelby tube sampler assembly. Attach the Shelby tube assembly to the center rods.
8. Lower the Shelby tube and center rods into the hollow-stem augers and seat it at the bottom. Be sure to leave 30 inches or more of center rod above the lowest point to the hydraulic piston's extension.
9. Use the rig's hydraulic drive to push the Shelby tube into undisturbed soil. The tube shall be pushed with a slow, steady force. The pressure used by the driller to push the Shelby tube shall be noted in the field logbook.
10. When the Shelby tube has been advanced to its full length or to refusal, back off the hydraulic pistons. Attach a hoisting plug to the upper end of the center rod, slightly twist to break off the sample, and pull the apparatus out of the hole with the rig winch.

**Subsurface Soil Sampling**

SOP 1-4

Revision: 8

Date: February 2015

11. Retrieve the Shelby tube to ground surface, detach it from the center rod, and remove the head assembly.
12. Since the typical intent of Shelby tube sampling is for engineering purposes and an undisturbed sample is required, the tube ends shall be sealed immediately. Sealing is accomplished by filling any void space in the tube with melted beeswax, then placing caps on the ends of the tube and taping caps into place. The top and bottom ends of the tube shall be marked and the tube transported to the laboratory in an upright position. ***It is extremely important that the Shelby tube samples are not disturbed in any way (dropped, rolled, subjected to extreme temperatures, etc.).***
13. Wipe sealed tubes with a clean Kimwipe or paper towel.
14. Indicate boring/well number and depth on outside of the tube.
15. Place sealed tubes in zip-top plastic bags, seal bags, and pack samples in a chilled cooler, if applicable.
16. Continue to advance the borehole to the next sampling point. Collect additional samples per the site-specific sampling plan as outlined above.
17. When sampling is complete, remove the drilling rig to the heavy equipment decontamination area.
18. Dispose of cuttings, plastic sheeting, etc., as specified in the site-specific work/sampling plans. Backfill borehole as specified in project- and /or site-specific work/sampling plans.
19. Complete the field logbook entry, being sure to record all relevant information before leaving the site.
20. Properly package all samples for shipment to laboratories and complete all necessary sample shipment documentation. Remand custody of the samples to appropriate personnel. See SOPs 1-2 and 2-1 or site-specific plans.

**5.2.5 Direct Push Rig Sampling**

**Note:** Steps 1 through 11 describe activities to be performed by a licensed drilling contractor, not CDM Smith personnel.

The following steps must be followed when collecting environmental samples using a direct push rig sampler:

1. Verify that the direct-push rig has been decontaminated at a separate location before drilling.
2. Attach the properly assembled sampler with appropriate liner to the end of the probe rod.
3. Attach drive cap and probe to the first designated sample depth, adding rod(s) as necessary.
4. Upon reaching the designated sample depth, remove the drive cap to access the inside of the probe rods.
5. Insert extension rods into probe rod; turn extension rod to release tip.
6. Retrieve extension rods, replace drive cap, add additional push rod if required, and push probe rod to the planned sample interval.
7. Attach pull cap and retrieve push rods and sampler.
8. Remove the sampler from the probe rod, and then remove the cutting shoe from the sampler.
9. Once the cutting shoe is removed, the liner containing the sample material can be removed from the sampler. Analytical samples can now be collected by CDM Smith personnel per site-specific plans and per Section 5.2.2 of this SOP.
10. When sample collection is complete, remove the push rig to the heavy equipment decontamination area.

**Subsurface Soil Sampling**

SOP 1-4

Revision: 8

Date: February 2015

11. Dispose of excess sample cuttings, plastic sheeting, etc., as specified in the site-specific plans.
12. Complete the field logbook entry, being sure to record all relevant information before leaving the site.
13. Properly package all samples for shipment to laboratories and complete all necessary sample shipment documentation. Remand custody of the samples to appropriate personnel. See SOPs 1-2 and 2-1 or site-specific plans.

**5.2.6 Backhoe Sampling**

**Note:** Steps 1, 2, 7, and 8 describe activities to be performed by a licensed heavy equipment operator, not CDM Smith personnel.

The following steps must be followed when collecting environmental samples using a backhoe:

1. Verify that the parts of the backhoe that will come in contact with the soil to be sampled have been decontaminated before excavation begins.
2. Excavate to the depth required in the site-specific plans.
3. Use a stainless steel trowel or scoop to obtain the sample material
4. Attach the trowel to a steel rod, wooden handle, or other similar device.
5. Remove the surface layer of soil "smeared" on the trench wall.
6. Replace the trowel with a clean trowel to collect a representative sample.
7. Analytical samples shall be collected by CDM Smith personnel per site-specific plans and per Section 5.2.2 of this SOP.
8. When sample collection is complete in the trench, backfill the trench with the excavated material, as appropriate.
9. Once the trench has been backfilled, move the backhoe to the heavy equipment decontamination area.
10. Dispose of excess sample cuttings, plastic sheeting, etc., as specified in the site-specific plans.
11. Complete the field logbook entry, being sure to record all relevant information before leaving the site.
12. Properly package all samples for shipment to laboratories and complete all necessary sample shipment documentation. Remand custody of the samples to appropriate personnel. See SOPs 1-2 and 2-1 or site-specific plans.

**5.3 Field Sampling/Preservation Methods**

The following three sections contain SW 846 Methods for sampling and field preservation. These methods include EnCore™ Sampler Method for low-level detection limits, EnCore Sampler Method for high-level limits/screening, and methanol preservation. Use of these methods may be required by the governing EPA Region, the client, or if required by the site-specific sampling plan. These methods are very detailed and contain equipment requirements at the beginning of each section.

When collecting soil samples using the EnCore Sampler Method, collection of soil for moisture content analysis is required. Results of this analysis are used to adjust "wet" concentration results to "dry" concentrations to meet analytical method requirements.

**Note:** Some variations from these methods, (e.g., sample volume) may be required depending on the contracted analytical laboratory.

**5.3.1.1 EnCore Sampler Equipment and Collection Requirements for Low-Level Analyses (<200 µg/kg)**

The following equipment is required for low-level analysis:

- Three 5 grams (g) samplers

**Subsurface Soil Sampling**

SOP 1-4

Revision: 8

Date: February 2015

**Note:** The sample volume requirements specified are general requirements. Actual sample volume and/or container sizes may vary depending on client or laboratory requirements.

- One 110-milliliter (mL) (4-ounce [oz.]) wide-mouth glass jar or applicable container for moisture analysis
- One T-handle
- Paper towels

The requirements for collecting low level analysis by the EnCore Sampler Method are as follows:

1. Wear clean gloves during handling of all sample containers and sampling devices.
2. Remove sampler and cap from package and attach T-handle to sampler body.
3. Quickly push the sampler into a freshly exposed surface of soil until the sampler is full. The O-ring will be visible within the hole on the side of the T-handle. If the O-ring is not visible within this window, then the sampler is not full.
4. Extract sampler and wipe the sampler head with a paper towel so that the cap can be tightly attached.
5. Push cap on with a twisting motion to secure to the sampler body.
6. Rotate the sampler stem counterclockwise until stem locks in place to retain sample within the sampler body.
7. Fill out sample label and attach to sampler.
8. Repeat procedure for the remaining two samplers.
9. Collect moisture sample in 110-mL (4-oz.) wide-mouth jar using a clean stainless steel spoon or trowel.
10. Store samplers at 4°C, ±2°C. Samples must be shipped and delivered to the analytical laboratory for extraction within 48 hours.

**Note:** Verify requirements for extraction/holding times.

**5.3.1.2 EnCore Sampler Equipment and Collection Requirements for High-Level Analyses ( $\geq 200 \mu\text{g}/\text{kg}$ )**

The following equipment is required for high-level analysis:

- One 5-g sampler or one 25-g sampler (the sampler size used will be dependent on client and laboratory requirements)
- One 110-mL (4-oz.) wide-mouth glass jar or applicable container specified for moisture analysis
- One T-handle
- Paper towels

The requirements for collecting high-level analysis by the EnCore Sampler Method are as follows:

1. Wear clean gloves during handling of all sample containers and sampling devices.
2. Remove sample and cap from package and attach T-handle to sampler body.
3. Quickly push the sampler into a freshly exposed surface of soil until the sampler is full. The O-ring will be visible within the hole on the side of the T-handle. If the O-ring is not visible within this window, then the sampler is not full.
4. Use clean paper toweling to quickly wipe the sampler head so that the cap can be tightly attached.
5. Push cap on with a twisting motion to attach cap.

**Subsurface Soil Sampling**

SOP 1-4

Revision: 8

Date: February 2015

6. Fill out a sample label and attach to sampler.
7. Rotate sampler stem counterclockwise until the stem locks in place to retain the sample within the sampler body.
8. Collect moisture sample in 110-mL (4-oz.) wide-mouth jar or designated container using a clean stainless steel spoon or trowel.
9. Store samplers at 4°C, ±2°C. Samples must be shipped and delivered to the analytical laboratory for extraction within 48 hours.

**Note:** Verify requirements for extraction/holding times.

**5.3.1.3 Methanol Preservation Equipment and Sampling Requirements for High-Level Analyses ( $\geq 200 \mu\text{g}/\text{kg}$ )**

The following equipment is required for methanol preservation sampling:

- One preweighed jar that contains methanol or a preweighed empty jar accompanied with a preweighed vial that contains methanol (laboratory grade)
- One dry weight cup
- Weighing balance that accurately weighs to 0.01 g (with accuracy of  $\pm 0.1$  g)
- Set of balance weights used in daily balance calibration
- Latex gloves
- Paper towels
- Cutoff plastic syringe or other coring device to deliver 5 g or 25 g of soil

The requirements for sampling and preservation are as follows:

1. Wear clean gloves during all handling of preweighed vials.
2. Weigh the vial containing methanol preservative to the nearest 0.01 g. If the weight of the vial with methanol varies by more than 0.01 g from the original weight recorded on the vial, discard the vial. If the weight is within tolerance, it can be used for soil preservation/collection below. (Commercial sources are available which supply pre-preserved and tared vials which eliminates the need to transport and handle larger quantities of methanol and eliminates the need for a precision scale vials with preservative).
3. Quickly collect a 5-g or 25-g sample using a cutoff plastic syringe or other coring device designed to deliver 5 g or 25 g of soil from a freshly exposed surface of soil. The 5-g or 25-g size used is dependent on client and laboratory requirements.
4. Carefully wipe the exterior of the collection device with a clean paper towel.
5. Quickly transfer the soil to an empty jar or a jar that contains methanol. If extruding into a jar that contains methanol, be careful not to splash the methanol outside of the vial. Again, the type of jar used is dependent on the client or laboratory requirements.
6. If the jar used to collect the soil plug was empty before the soil was added, immediately preserve with the methanol provided, using only one vial of methanol preservative per sample jar.
7. Using the paper toweling, remove any soil off of the vial threads and cap the jar.
8. Weigh the jar with the soil in it to the nearest 0.01 g and record the weight on the sample label.
9. Collect dry weight sample using a clean stainless steel spoon or trowel.
10. Store samples at 4°, ±2°C.

## Subsurface Soil Sampling

SOP 1-4

Revision: 8

Date: February 2015

11. Ship sample containers with plenty of ice in accordance with DOT regulations (CORROSIVE. FLAMMABLE LIQUID. POISON) to the laboratory.

### 6.0 Restrictions/Limitations

- Basket or spring retainers may be needed for split-barrel sampling in loose, sandy soils.
- A larger-diameter split spoon sampler assembly in addition to the standard split spoon assembly is recommended for all projects on which environmental sample collection from discrete intervals may be required. This enables additional sample material to be recovered in the event the initial split spoon sample does not yield adequate sample material. This method is not recommended for the collection of samples that are to be analyzed for VOCs.
- Shelby tubes are most appropriately used to sample cohesive materials, and may not retain sample material in loose, sandy soils.
- When grab sampling for VOC analysis or for analysis of any other compound(s) that may be degraded by aeration, it is necessary to minimize sample disturbance and consequently minimize analyte loss. The representativeness of a VOC grab sample is difficult to determine because the collected sample represents a single point, is not homogenized, and has been disturbed.

### 7.0 References

American Society for Testing and Materials. 2011. *Standard Test Method for Penetration Test (SPT) and Split Barrel Sampling of Soils*. Standard Method D1586-11.

\_\_\_\_\_. 2000. *Standard Test Method for Thin-Walled Tube Sampling of Soils for Geotechnical Purposes*. Standard Method D1587-08(2012)e1.

U. S. Environmental Protection Agency. *Test Methods for Evaluating Solid Waste, Physical/Chemical Methods (SW-846)*, Third Edition, November 1986, (as amended by Updates I, II, IIA, IIB, III, and IIIA, IIIB, and IVA, IVB). Method 5035 (**Note**: § 6.2.1.8 of this method says samples stored in EnCore™ samplers shall be analyzed within 48 hours or transferred to soil sample vials in the laboratory within 48 hours): December 1996, Revision O, Closed-System Purge-and-Trap and Extraction for Volatile Organics in Soil and Waste Samples.

\_\_\_\_\_. 2014. Region 4. *The Field Branches Quality System and Technical Procedures, Soil Sampling*. SESDPROC-300-R3. August.

**Groundwater Sampling Using Bailers**

SOP 1-5

Revision: 9

Date: February 2015

Approved:

  
Signature

Technical Review:

David Schroeder

**1.0 Objective**

The purpose of this technical standard operating procedure (SOP) is to define requirements for the collection of groundwater samples with bailers.

**2.0 Background**

Collection of groundwater samples from monitoring wells on or near a hazardous waste site may be required to characterize the nature and extent of contamination.

Methods used for the collection of groundwater samples include bailing and a variety of pumping techniques. Bailers are hollow cylinders with unidirectional (open up) check valves at the bottom end. Some bailers may also be closed or valved at the upper end. Bailers used in environmental applications are typically constructed of polyvinyl chloride (PVC), polyethylene, stainless steel, or Teflon®. Disposable polyethylene, PVC, and Teflon bailers are commonly used and eliminate the possibility of cross contamination as a result of poor decontamination. The bailer line typically consists of disposable nylon cord, disposable polypropylene cord, or Teflon-coated stainless steel wire. The bailer is slowly lowered into the well using an acceptable type of line until submerged. The bailer is then retrieved to the surface for sample collection. For the best results, the sequence of sampling is from least to most contaminated wells. It is preferable to have bailers dedicated to each monitoring well.

**2.1 Associated Procedures**

- SOP 1-2, *Sample Custody*
- SOP 1-6, *Water Level Measurement*
- SOP 2-1, *Packaging and Shipping Environmental Samples*
- SOP 4-1, *Field Logbook Content and Control*
- SOP 4-3, *Well Development and Purging*
- SOP 4-5, *Field Equipment Decontamination at Nonradioactive Sites*

**3.0 General Responsibilities**

**Site Manager** - The site manager is responsible for ensuring that field personnel are trained in the use of this procedure and for verifying that groundwater samples are collected in accordance with this procedure.

**Field Team Leader** - The field team leader is responsible for ensuring that sampling efforts are conducted in accordance with this procedure and any associated SOPs.

**Note:** Responsibilities may vary from site to site. Therefore, all field team member responsibilities shall be defined in the field plan or site/quality assurance project plan (QAPP).

**4.0 Required Equipment**

- Site-specific plans
- Field logbook
- Indelible black ink pens and markers
- Labels and appropriate forms/documentation for sample shipment
- Sample chain-of-custody forms
- Insulated cooler and waterproof sealing tape (strapping tape)
- Plastic zip-top bags

**Groundwater Sampling Using Bailers**

SOP 1-5

Revision: 9

Date: February 2015

- Ice double-bagged in plastic zip-top bags
- Bailer of the appropriate design and construction for the sampling application
- Clean bailer line of sufficient length for well condition
- Water level meter and/or other water level measuring device
- Clean beaker(s) or other container for measurement of water quality parameters
- Plastic sheeting (4-mil thickness)
- Latex or appropriate gloves
- Filtering apparatus (e.g., peristaltic pump), if required
- Appropriate sample containers with labels and preservatives, as required
- Temperature, conductivity, pH, dissolved oxygen, turbidity, and other meters as required by the site-specific field sampling plan
- Photoionization detector (PID) or equivalent and other instruments as required by the site-specific health and safety plan
- Decontamination supplies, as required by SOP 4-5
- Personal protective clothing and equipment as required by the site-specific health and safety plan

**5.0 Procedures**

1. Review site-specific health and safety plan and project plans before initiating sampling activity.
2. Don personal protective clothing and equipment as specified in the site-specific health and safety plan. All field equipment will be calibrated, tested, or checked for proper functioning before use per the manufacturer's instructions.
3. Prepare the site for sample acquisition. If required, cover the ground surface around the wellhead with plastic sheeting. Arrange the required decontaminated sampling and monitoring equipment for convenient use. If onsite decontamination is required, arrange the necessary supplies in a nearby but separate location, away from the wellhead (i.e., in an exclusion zone).
4. Open the well and note the condition of the casing and cap. Immediately check for organic vapors using a PID or flame ionization detector as appropriate. Refer to the site health and safety plan for the required monitoring and frequencies.
5. Determine the static water level and depth to well bottom in accordance with SOP 1-6. Record this information in the field logbook and/or on the appropriate form.
6. Purge the well according to SOP 4-3. Allow the water level in the well to recover to 75 percent of its static level so that a representative sample of the screened portion of the aquifer can be obtained. The bailer shall be completely submerged so that it does not contact the bottom of the well which may introduce sediment into the groundwater sample. Samples shall be collected within 3 hours of purging if recharge is sufficient. Wells with a low recharge rate must be collected within 24 hours of purging.
7. Securely attach the bailer to the line. The opposite end of the line shall be secured to prevent loss of the bailer into the well.
8. Arrange the sample containers in the order of use. Samples to be analyzed for volatile organic compounds (VOCs), if required, shall be obtained first, followed in order by other organic samples, then inorganic samples and other parameters. For example:
 

|                                     |                         |
|-------------------------------------|-------------------------|
| a) VOCs                             | g) Total metals         |
| b) Purgeable organic carbon (POC)   | h) Dissolved metals     |
| c) Purgeable organic halogens (POX) | i) Cyanide              |
| d) Total organic halogens (TOX)     | j) Sulfate and chloride |
| e) Total organic carbon (TOC)       | k) Nitrate and ammonia  |
| f) Extractable organics*            | l) Radionuclides        |

\*Extractable organics include semivolatile organic compounds, pesticides, and PCBs.



**Groundwater Sampling Using Bailers**

SOP 1-5

Revision: 9

Date: February 2015

9. Don clean sampling gloves; lower the decontaminated or disposable bailer into the well. The bailer shall enter the water slowly to prevent aeration, particularly when VOC samples are being collected. Do not allow the bailer to come in contact with the well bottom.
10. Retrieve the filled bailer to the surface. To prevent contamination of the bailer line, do not allow line to contact the ground, rather keep line in a clean pail or other clean container. Hang the bailer from a bailer stand or other support, if available, or have an assistant hold it off the ground. Immediately obtain any required volatile samples (VOC, POC, POX, TOX, or TOC) by gently transferring water from the bailer to the sample bottle through a VOC sampling device inserted into the bottom of the bailer. Care shall be taken to adjust the flow of the water into the vial so that it is not too fast. The vial shall also be tilted so that the stream of water is directed down the side of the vial to reduce nonlaminar flow into the vial and to prevent aeration. Check the filled VOC vials for bubbles. If bubbles are present in a vial, discard it and fill another vial from the bailer. After collecting volatile samples, lower the bailer to collect additional water for the remaining parameters. If sample filtration is required for metals, it shall be performed immediately following sample retrieval, and before sample preservation. Organic samples generally do not require filtration; VOC samples are never filtered. Preservation of samples shall be performed according to the applicable field plan. Check the pH on samples (other than VOCs) that require preservation. Collect additional quality assurance/quality control samples (i.e., duplicate samples) as required by the applicable field plan.
11. Wipe the outer surfaces of the sample containers clean with a Kim-wipe or clean paper towel. Additional sample bottle decontamination may be appropriate in some cases.
12. Properly label all containers according to SOP 2-1.
13. Place sample containers in individual zip-top plastic bags and seal the bags (if required by site-specific plans).
14. Immediately pack all sample containers that require a 4°C preservation on ice in coolers (refer to SOP 2-1 and site-specific plans).
15. Record the parameters to be analyzed and volumes collected, and time and date of collection in the field logbook. Prepare chain-of-custody forms according to site-specific plans and SOP 1-2.
16. Decontaminate sampling equipment as needed, according to SOP 4-5.
17. Close and lock the well cover. Clean up the area and place disposable materials (plastic sheeting, gloves, Tyvek®) in the designated waste receptacle.
18. If required by the site-specific field sampling plan, obtain required field measurements such as temperature, conductivity, pH, oxidation potential (Eh), turbidity, salinity, or dissolved oxygen measurements immediately after samples have been collected and record them in the field logbook.

**6.0 Restrictions/Limitations**

Careful sampling for VOC analysis or for analysis of any other compound(s) that may be degraded by aeration is necessary to minimize sample disturbance and, hence, analyte loss. The representativeness of this sample, however, is difficult to determine because the collected sample represents a single point, is not homogenized, and has been disturbed.

Use of nondisposable bailers may contribute to cross contamination if proper and thorough decontamination procedures are not followed.

## Groundwater Sampling Using Bailers

SOP 1-5

Revision: 9

Date: February 2015

### 7.0 References

Office of Solid Waste and Emergency Response. 1992. *RCRA Ground-water Monitoring: Draft Technical Guidance*, EPA/530/R-93/001. November.

Office of Solid Waste and Emergency Response. 1986. *RCRA Groundwater Monitoring Technical Guidance Enforcement Document*, OSWER-9950.1. September.

ASTM International. 2001. Standard Practice for Sampling Liquids Using Bailers. Standard Method D6699-01 (2010).

**Groundwater Level Measurement**

SOP 1-6

Revision: 9

Date: February 2015

Approved:

  
Signature

Technical Review:

David Schroeder

**1.0 Objective**

Groundwater level measurements are fundamental to groundwater and solute transport studies and are conducted during groundwater sampling events to calculate the amount of groundwater to be purged from the well. This technical standard operating procedure (SOP) defines the techniques and requirements for obtaining depth to groundwater (or groundwater level) measurements.

**2.0 Background****2.1 Definitions**

**Water Level Indicator** - A portable device for measuring the depth from a fixed point (which could be below, at, or above the ground surface) to groundwater inside a well, borehole, or other underground opening.

**Measurement Point** - An easily located and clearly defined mark at the top of a well from which all water level measurements from that particular well are made. The measurement point shall be as permanent as possible to provide consistency in measurements.

**Electrical Tape** - A graduated plastic tape onto which a water-sensitive electrode is connected that will electronically signal the presence of water (as a result of circuit closure).

**Immiscible Fluids** - Two or more fluid substances that will not mix and, therefore, will exist together in a layered form. The fluid with the highest density will exist as the bottom layer, the fluid with the lowest density will exist as the top layer, and any other fluid layers will be distributed relative to their respective densities.

**Discharge** - The removal/release of water from the zone of saturation.

**Recharge** - The addition of water to the zone of saturation.

**Static Water Level** - The level of water in a well, borehole, or other underground opening that is not influenced by discharge or recharge.

**Well Casing** - A steel, stainless steel, or polyvinyl chloride pipe that extends into a borehole and is connected to the well screen or sealed at the bedrock surface in open-hole wells. The upper portion (approximately 3 to 4 feet) of the well casing is normally enclosed by an outer steel protective casing.

**Protective Casing** - A steel cylinder or square protective sleeve extending approximately 3 to 5 feet into the ground, surrounding the well casing. For flush-mounted wells, the protective casing will extend only high enough so that the well and protective casing can be enclosed by a Christy box or equivalent vault. In above-grade wells, the protective casing will extend above the ground surface approximately 2 to 3 feet. The protective casing protects the well casing.

**2.2 Associated Procedures**

- SOP 4-1, *Field Logbook Content and Control*
- SOP 4-5, *Field Equipment Decontamination at Nonradioactive Sites*

**2.3 Discussion**

The most common uses of static water level data are to: determine the elevation of groundwater, the direction of groundwater flow, identify areas of recharge and discharge, evaluate the effects of manmade and natural stresses on the groundwater system, define the hydraulic characteristics of aquifers, and evaluate stream-aquifer relationships. Specific uses for water level data may include:

## Groundwater Level Measurement

SOP 1-6

Revision: 9

Date: February 2015

- Determining the change in water level due to distribution and rate of regional groundwater withdrawal
- Showing the relationship of groundwater to surface water
- Estimating the amount, source, and area of recharge and discharge
- Determining rate and direction of groundwater movement

Static water level measurements shall be obtained from each well before purging, sampling, or other disturbance of the water table.

### 3.0 General Responsibilities

**Project Manager** - The project manager is responsible for ensuring that measurements are conducted in accordance with this procedure and any other SOP pertaining to site activities related to obtaining groundwater level measurements.

**Field Team Leader** - The field team leader is responsible for ensuring that field personnel obtain water level measurements in accordance with this and other relevant procedures.

**Note:** Responsibilities may vary from site to site. Therefore, all field team member responsibilities shall be defined in the field sampling plan or site/quality assurance project plan (QAPP).

### 4.0 Required Equipment

#### 4.1 General

- Site-specific plans
- Field logbook
- Indelible black ink pens
- Permanent felt-tip marker (e.g., Sharpie)
- Personal protective equipment
- Decontamination equipment and supplies, including rinse bottles and deionized water
- Tap water and large beaker or bucket
- Water level meter

#### 4.2 Measuring Devices

The equipment required to obtain water level measurements is dependent on the type of procedure chosen. Measurements may be made with a number of different devices and procedures. Measurements are taken relevant to a permanent measurement point on the well riser.

Electrical tapes are preferred over other devices such as steel tape because of the electrical tape's simplicity and ability to make measurements in a short period of time. Many types of electrical instruments have been devised for measuring water levels; most operate on the principle that a circuit is completed when two electrodes are immersed in water. Examples of electrical tapes that are frequently used include the Slope Indicator Co.® and Solinst® electronic water level indicators. These instruments are powered by batteries that shall be checked before mobilization to the field.

Electrical tapes are coiled on a hand-cranked reel unit that contains the batteries and a signaling device that indicates when the circuit is closed (i.e., when the probe reaches the water). Electrodes are generally contained in a weighted probe that keeps the tape taut in addition to providing some shielding of the electrodes against false indications as the probe is being lowered into the hole. The electrical tapes are marked with 0.01-foot increments. Caution shall be exercised when using electrical tapes when the water contains elevated amounts of dissolved solids. Under these conditions, the signaling device will remain activated after the probe is removed from the water. When the water being measured contains very low amounts of dissolved solids, it is possible for the probe to extend several inches below the water level before activating the signaling device. Both of these conditions are related to the conductivity of the water and in some cases may be compensated for by the sensitivity control, if the device has this option. In groundwater with high conductivity the sensitivity control may need to be turned down, and in groundwater with low conductivity the sensitivity control may need to be turned up to obtain a proper depth to groundwater measurement.

## Groundwater Level Measurement

SOP 1-6

Revision: 9

Date: February 2015

### 5.0 Procedures

#### 5.1 Preparation

The following steps must be taken when preparing to obtain a water level measurement:

1. Assign a designated field logbook to record all field events and measurements according to SOP 4-1. Document any and all deviations from SOPs and site-specific plans in the field logbook and include rationale for the changes.
2. Always exercise caution to prevent inappropriate or contaminated materials from entering an environmental well.
3. Standing upwind from the well, open the groundwater well. Monitor the well with a photoionization detector, flame ionization detector, or equivalent vapor analyzer as soon as the cap is opened, as dictated by the site-specific health and safety plan.

For comparability, water level measurements shall always be referenced to the same vertical (elevation) datum marker, such as a U. S. Geological Survey (USGS) vertical and horizontal control point monument. The elevations calculated from the measurement of static water levels shall be referenced to mean sea level unless otherwise specified in the site-specific plans.

The measurement point must be as permanent as possible, clearly defined, marked, and easily located. Frequently, the top of the PVC riser is designated as the measurement point. However, since the top of the riser is seldom smooth and horizontal, one particular point on the riser pipe shall be designated and clearly marked. This can be accomplished by marking a point on the top of the riser pipe with a permanent marker. To avoid spilling liquids into the well, paints or other liquid marking materials shall not be used.

#### 5.2 Water Level Measurement Using Electrical Water Level Indicators

The following steps must be followed when taking water level measurements using electrical tapes:

1. Before lowering the probe into the well, the circuitry shall be checked by dipping the probe in tap water and checking to ensure that the signaling device responds to probe submergence. The probe shall then be lowered slowly into the well until contact with the water surface is indicated. The electrical tape reading is made at the measuring point. Take a second and third check reading to verify the measurement before completely withdrawing the tape from the well. All three measurements shall be recorded in the field logbook.
2. Independent electrical tape measurements of static water levels using the tape shall agree within  $\pm 0.01$  foot for depths of less than about 200 feet. At greater depths, independent measurements may not be this close. For a depth of about 500 feet, the maximum difference of independent measurement using the same tape shall be within  $\pm 0.1$  foot.
3. Decontaminate the electrical tape according to SOP 4-5 before proceeding to the next well to minimize cross contamination.

It may be necessary to check the electrical tape length with a graduated steel tape after the line has been used for a long period of time (at least annually) or after it has been pulled hard in attempting to free the line. Some electrical tapes, especially the single line wire, are subject to becoming permanently stretched.

#### 5.3 Other Water Level Measurement Methods

Although the method cited above (electrical water level indicator) for measuring water levels predominates in the environmental sector, there are a number of other methods available that may be well suited for a particular purpose.

##### 5.3.1 Ultrasonic Method

The ultrasonic method electronically measures the amount of time it takes a sound wave to reach and reflect off the water surface and return to the ground surface. These instruments contain electronic microprocessors, capable of performing this measurement many times each second. The actual depth to water, as calculated by the microprocessor, is an average of many individual readings.

## Groundwater Level Measurement

SOP 1-6

Revision: 9

Date: February 2015

### 5.3.2 Pressure Gauge Method

This method, also called the air-line submergence method, uses a pressure gauge and is the preferred method for obtaining water level measurements in pumping wells. An air line constructed of semi-rigid tubing is inserted into the well below the water table. The tube end at the surface is connected to an air tank or compressor and pressure gauge. Filtered air is then forced through the tube and the resultant pressure is read in pounds per square inch (psi). This reading is converted to feet of water in the column and subtracted from the total tube length to give depth to water. Readings are then converted to groundwater elevation. Results are plotted on a field logging form. Calibration records and the exact procedures used must be maintained.

### 5.3.3 Acoustic Probe Method

The acoustic probe is an electronic device containing two electrodes and a battery-powered transducer. The probe is attached to a tape. The probe is lowered into the well until a sound is detected, indicating the electrodes in the probe have contacted the water surface. This method is similar to the electrical probe method discussed in Section 5.2.

### 5.3.4 Continuous Recording Method

The measurement of groundwater elevations within pumping or monitoring wells can be accomplished by the use of a mechanical or digital analog computerized continuous recording system and shall be performed according to specifications given by the manufacturer of each unit. In general, when using the mechanical or digital system, the pressure or electrical transducer is lowered into the well until it intersects the water surface. The actual depth to water is then measured by one of the methods described above and used to calibrate the continuous recorder.

The necessary adjustments and preparations are then completed according to the specifications given for each type of continuous recorder. Proper maintenance of continuous recording devices during water level monitoring shall be performed such that continuous, permanent records are developed for the specified period of time. Records shall be stored on mechanical graph paper or on a microprocessor. Frequent calibrations of equipment shall also be made during monitoring periods of long duration in accordance with the manufacturers' specifications.

## 6.0 Restrictions/Limitations

### 6.1 Groundwater and Miscible Fluids

Where water is rapidly dripping or flowing into a well, either from the top of the well or from fractures, obtaining an accurate reading may not be possible.

The effect of the water flowing into the well may interfere with an electronic water level measuring device, resulting in a false water level measurement. If water levels must be recorded in wells completed in aquifers that are recharging or discharging, the electronic water level indicator is the preferred measuring device, but shall be used with the awareness of possible false measurements. To minimize the effects of "splashing," a 1-inch pipe (decontaminated for environmental wells) may be lowered into the pumping well into which the water level indicator is then inserted. This will minimize the effect of "splashing" until the probe contacts the groundwater. It will also protect the probe from becoming tangled in pump wiring or well spacers associated with downhole equipment such as submersible pumps.

### 6.2 Immiscible Fluids

For wells containing immiscible contaminants, the field personnel will need to use special procedures for the measurement of fluid levels. The procedure to follow will depend on whether layers are light immiscibles that form lenses floating on the top of the water table, or dense immiscibles that sink through the aquifer and form lenses over less permeable layers.

In the case of light immiscibles, measurements of immiscible fluid and water levels cannot be accomplished by using normal techniques. A conventional electrical tape often will not respond to nonconducting immiscible fluids.

**Groundwater Level Measurement**

SOP 1-6

Revision: 9

Date: February 2015

Techniques have been specially developed to measure fluid levels in wells containing immiscible fluids, particularly petroleum products. A special paste or gel applied to the end of the steel tape and submerged in the well will show the top of the oil as a wet line and the top of the water as a distinct color change, or an interface probe can be used that will detect the presence of conducting and nonconducting fluids. Thus, if a well is contaminated with low density, nonconducting immiscible fluids such as gasoline, the probe will first detect the surface of the gasoline, but it will not register electrical conduction. However, when the probe is lowered deeper to contact water, it will detect electrical conduction. Normally, a variation in an audible signal indicates the difference between phases.

Both of these methods have disadvantages. They are less effective with heavier and less refined petroleum products because the product tends to stick to the tape or probe, giving a greater product thickness measurement than is present. Paste or gel cannot be used when sampling groundwater for the same constituents present in the paste or gel product.

Note that water levels obtained in this situation are not suitable for determining hydraulic gradients without further interpretation. To use such data for determining hydraulic gradients, the difference in density between the light immiscible phase and water has to be considered.

Measuring fluid levels in wells screened in lenses of dense immiscible fluids resting on a low permeability formation is somewhat easier, provided the immiscible fluid is nonconducting. The top of the dense layer can be identified by simply using an electrical sounder. As an electrical sounder passes from groundwater into the immiscible phase, the detection unit will deactivate because the fluid will no longer conduct electricity. A better method would be to use an interface probe as described above. The variation in the audible signal associated with the detection of differing phase liquids will also allow the user to obtain a groundwater depth and dense immiscible thickness measurement.

## 7.0 References

U. S. Environmental Protection Agency. 1987. *A Compendium of Superfund Field Operations Methods*. EPA/540/P-87/001. December.

\_\_\_\_\_. 2013. Region 4. The Field Branches Quality System and Technical Procedures, Groundwater Level and Well Depth Measurement. SESDPROC-105-R2. January

Weight, Willis D. and Sonderegger, John L., 2001. *Manual of Applied Hydrogeology*. Lewis Publishing Company. 187-190.

## Vapor Sampling Using a SUMMA® Canister

TSOP 1-8

Revision: 8

Date: February 2015

Approved:

  
Signature

Technical Review:

John Eisenbeis

### 1.0 Objective

The purpose of this technical standard operating procedure (TSOP) is to define procedures and requirements for collection of vapor using evacuated SUMMA® canister samplers.

### 2.0 Background

Collection of discrete or temporally composited vapor samples from designated locations on or near a hazardous waste site may be required to characterize and model the nature and extent of ambient, indoor or subsurface contamination. The sampling method described in this TSOP is adapted from U.S. Environmental Protection Agency Method TO-15 Second Edition 1999.

Two types of vapor samples can be collected with SUMMA canisters. The canister can be opened and allowed to fill over a short period to obtain a grab sample or filled slowly by using a flow controller to collect a time-integrated sample.

### 2.1 Definitions

**Canister** - Leak-free stainless steel pressure vessels of desired volume (e.g., less than 1 liter (L) to greater than 6 L) are available, with valves and specially prepared (SUMMA) nonreactive interior surfaces. The canister is initially evacuated (under high vacuum) at the laboratory to approximately -30 inches of mercury (Hg). The canisters must be properly cleaned at the laboratory before each use by either ultra-pure humidified air in a series of evacuation/pressurization cycles or in a high temperature oven. The canister is then analyzed by gas chromatograph/ mass spectrophotometer (GC/MS) to verify cleanliness. **Note:** Canisters previously used for the measurement of high-level contamination may not be suitable for indoor air monitoring, since they may not be able to be adequately decontaminated. A 100 percent certification (individual certification) process is appropriate for ambient and indoor air SUMMA canister sampling applications.

**Particulate Matter Filter** – 2 or 7-micron filters are built into the flow controllers. The 7-micron filter is primarily used with grab samples. The 2-micron filter is standard for integrated samples. A separate laboratory-cleaned filter is used for each canister sample.

**Stainless Steel Vacuum/Pressure Gauges** - A gauge capable of measuring vacuum (0 to -30 inches Hg or -100 to 0 kilo pascals [kPa]) and pressure (0 to 30 pounds per square inch [psi] or 0 to 206 kPa) is needed to verify the initial canister vacuum and to measure sampling progress in the sampling system. Gauges shall be tested clean and leak tight.

**Sampling Inlet Line/Connectors** - Stainless steel or Teflon® tubing (all usually ¼-inch diameter) and appropriate air-tight connectors (e.g., Swagelok® tube fittings) connect the canister to the sample inlet. A Swagelok fitting has four parts, the connector body, two ferrules, and a nut. The larger (cone-shaped) ferrule fits into the connector body, small diameter end first. The smaller end of the smaller ferrule fits on top of the cone ferrule, and the nut is screwed on top. The tubing fits through the nut and the two ferrules, and seats firmly in the connector. On newly created fittings, the nut shall be tightened with two wrenches, 1¼ turns past finger tight to compress the ferrules onto the tubing. Swagelok makes an inspection gauge that fits between the nut and the connector body if a large number of critical connections are to be made. Connections that have been previously made up will only need a short tighten with the wrenches past finger tight.

**Stainless Steel Shut-Off Valve** - Leak free, for vacuum/pressure gauge.

**Electronic Mass Flow Controller** - This controller, used to collect composite samples, must be capable of maintaining a constant flow rate (±10 percent) over a sampling period of up to 24 hours and under conditions of changing temperature (20 to 40 degrees Celsius [°C]) and humidity.



## Vapor Sampling Using a SUMMA® Canister

TSOP 1-8

Revision: 8

Date: February 2015

**Auxiliary Vacuum Pump** – The pump continuously draws air through the inlet manifold at 10 L/minute or higher flow rate. The canister vacuum extracts a sample from the manifold at a lower flow rate, and excess air is exhausted. **Note:** The use of higher inlet flow rates dilutes any contamination present in the inlet and reduces the possibility of sample contamination as a result of contact with active adsorption sites on inlet walls. The auxiliary pump and sampling manifold can also be used to purge vapor monitoring wells.

**Elapsed Time Meter/Stopwatch** - Measures duration of sampling.

### 2.2 Associated Procedures

- TSOP 1-2, *Sample Custody*
- TSOP 4-1, *Field Logbook Content and Control*
- TSOP 1-10, *Field Measurement of Organic Vapors*

### 2.3 Discussion

Ambient air, emission source, or vapor monitoring well samples are collected to determine the type(s) and level(s) of contamination from airborne toxic organic compounds (often important to risk assessment), characterize subsurface vapor contamination, or evaluate vapor intrusion into buildings. These samples may be collected as part of an investigative plan, site-specific sampling plan, and/or as a screen for “hot spots,” which may require more extensive sampling. Sampling will include necessary quality assurance/quality control (QA/QC) samples as documented in the project-specific Quality Assurance Program Plan (QAPP), and a field blank and trip blank shall accompany all sampled media.

### 3.0 Responsibilities

**Site Manager** - The site manager is responsible for ensuring that SUMMA canister sampling efforts are performed consistently with this procedure and other project-specific documents such as the QAPP, work plan, sampling plan, and the health and safety plan.

**Field Team Leader** - The field team leader is responsible for ensuring that field personnel collect vapor samples in accordance with this or the project-specific procedure in the field plan and that appropriate documentation is collected.

**Note:** Responsibilities may vary from site to site. Therefore, all field team member responsibilities shall be defined in the field plan or site-/project-specific quality assurance plan.

### 4.0 Required Equipment/Supplies

- Site-specific plans
- Adjustable wrenches (two 9/16-inch opened end wrenches for Swagelok fittings)
- Labels/canister tags (shall be attached to canister) and appropriate laboratory-supplied, individual canister-specific, chain-of-custody forms
- Field logbook or field forms
- Documentation for sample shipment
- Items listed in Section 2.1, Definitions, as applicable
- Sturdy shipping container(s)

### 5.0 Procedures

#### 5.1 Preparation

1. The analysis of vapor samples collected in canisters will have very low detection limits. Canister preparation shall therefore be performed in clean air environments, away from any type of volatile organic contamination. The canisters are expensive, and, although relatively sturdy, valves and connections can be easily damaged. Do not over tighten valves. Use two wrenches to remove and reconnect line caps and attachments. Using a single wrench may cause excessive torque on the fitting/canister connection.

**Vapor Sampling Using a SUMMA® Canister**

TSOP 1-8

Revision: 8

Date: February 2015

2. Check the number on the permanent label/tag attached to the canister against the laboratory-supplied chain-of-custody form. Verify that the canister number on the form agrees with the label. Note the date the canister was cleaned, preevacuated canister vacuum, and laboratory analysis verification, etc. The supplied paperwork will vary depending on the laboratory supplying the canister. The objective is to verify that the canister is the correct one, has been cleaned, and has been evacuated to a vacuum approximately -30 inches Hg.
3. In a clean environment, use two wrenches to remove the Swagelok cap from the end of the canister and attach a clean vacuum gauge. Verify that the gauge reads zero. Tighten the gauge fitting tightly with the wrenches. Open the canister valve, read the gauge, and record the reading on the chain-of-custody. SHUT THE VALVE TIGHTLY (turn clockwise). The vacuum reading shall agree closely (the field gauge may not be as accurate as the gauge in the laboratory) with the vacuum noted by the laboratory. If the field vacuum is more than 1 inch of Hg less than the laboratory vacuum, then the canister valve has leaked during the time since the canister was evacuated, and a portion of the canister has been filled with unknown vapor. If the vacuum is not sufficient, replace the canister and document the change. If there are questions, call the laboratory that supplied the canister to discuss further action.
4. If the two vacuum readings agree and the canister is suitable for use, verify that the valve is closed tightly, and remove the vacuum gauge. Attach a clean sample filter (supplied by the laboratory) and replace the Swagelok cap on the filter.
5. If required, build a sampling apparatus using appropriate tubing, connectors, or valves to connect the canister to the sampling location.
6. If a vacuum pump is to be used to purge a soil vapor monitoring well, insert a "tee" fitting between the well and the vacuum pump (upstream of the pump), and a line valve between the tee fitting and the pump. During purging, the line valve is opened and the third leg of the tee is capped, allowing the pump to pull air from the well without short-circuiting through the tee. If a portable photoionization detector (PID), flame ionization detector (FID), or other real-time instrument is to be used to take a field screening reading from the well, a second tee fitting shall be installed on the downstream side of the pump exhaust port. The probe of the instrument is inserted into one leg of the tee, while the other leg is allowed to vent, to prevent pressurizing the instrument and creating false readings.

**5.2 Using a Flow Controller for Time-Integrated (Temporally Composited) Sampling**

1. To ensure the correct time-integrated sampling rate, the flow controller must be calibrated by a certified laboratory to maintain a constant flow into the canister over the desired sample period. In general, flow controllers are set to standard atmospheric conditions. If the air sample is collected at an elevation or under vacuum, the flow controller needs to be calibrated accordingly. Under standard atmospheric conditions, if a 6-L canister is selected, the flow controllers are usually set to collect a 5-L sample over the sampling interval. The flow rate can be calculated by -  

$$\text{Flow Rate (ml/min)} = \text{Target fill volume (ml)} / \text{Sampling interval (min)}$$
2. The evacuated canister, flow controller (if required), vacuum gauge, particulate matter filter, and sample inlet need to be assembled (if not already pre-assembled by the offsite laboratory) using two open-end wrenches to tighten the tubing and sampling system components to the canister valve stem.
3. Data entries on the daily sample event data sheet (or equivalent) shall include serial numbers for all numbered sampling components, sample initiation time, sample identification number, sample collection time, separate entries for sub-atmospheric SUMMA canister pressures at sample initiation and completion, sampler initial(s), initiation date, collection date, and sample tag custody number.

**5.3 Sample Collection**

1. The sample system assembly is transported to the required sample location. Before collecting each sample, confirm that the canister number and sample identification corresponds to the correct sample location.

## Vapor Sampling Using a SUMMA<sup>®</sup> Canister

TSOP 1-8

Revision: 8

Date: February 2015

2. If using a vacuum pump to purge a vapor monitoring well or other space, begin preparing the canister when sufficient purging of the well has been accomplished. Attach a canister with the valve closed to the third leg of the tee upstream of the pump (discussed in Section 5.1), while the pump continues to pull vapor from the well. Do not connect the canister to the downstream side of the pump since the pump may contain contaminants that may be introduced into the sample. The sample is drawn into the canister by the vacuum. When it is time to collect the sample, the valve between the canister and the pump is shut off, preventing backflow through the pump if the canister vacuum happens to be stronger than the pump.
3. When collecting a grab (not a temporally composited) sample, check the tightness of all fittings on the sampling apparatus and the connections on the canister. If sampling ambient air or an emission source, position the canister inlet in the intended environment with the inlet line pointed downward to prevent rainwater from entering the canister.
4. To initiate a sample event, gently open (counter clockwise) the canister valve until a hissing noise is heard. Note the initial vacuum reading on the gauge (attached to the canister with a tee) and that the vacuum level begins to drop. There are differing opinions on how long to allow for the canister to fill, and whether there is any negative effect of opening the valve rapidly. A good compromise is to adjust the valve so there is a slow hiss, allowing the canister to fill in about a half minute. The canister valve can be closed before the hissing stops and the vacuum gauge reaches 0 inches Hg. Record the final vacuum level on the chain-of-custody. Close the valve firmly, without overtightening.
5. Remove the canister from the sampling apparatus, remove the gauge and filter, and replace the canister cap. Do not use the same filter to collect another sample.
6. Record the final vacuum level, duration of sample collection, and any other pertinent sampling information of the chain-of-custody. The final vacuum of a 6-L canister should be between 5 to 10 inches Hg. Complete documentation on the daily event datasheet and the field logbook before leaving each sample location.
7. Place the canister in a sturdy container for shipping. Place all of the used filters in a plastic baggie and return them to the laboratory with the canisters.

### 6.0 Restrictions/Limitations

The nonreactive inner surface of the SUMMA canister may not be compatible for sampling atmospheres with high levels of chlorine or sulfur. Contact the analytical laboratory for guidance when these elements are suspected.

For 24-hour time-integrated sampling, sample flow rates through the vacuum gauge of the sample system may not remain stable (within the method flow rate tolerance) at vacuums less than 9 inches Hg (e.g., 8 inches Hg). Caution shall be taken in using 24-hour time-integrated samples where final vacuum is less than 4 inches Hg. Flow rates at this vacuum and below are not constant, yielding potentially nonrepresentative results during the latter portion of the sampling period. Any canister that has reached 0 inches Hg vacuum may not be a representative 24-hour sample.

Samples collected at vacuums above 10 inches Hg (e.g., when the canister valve is closed before the gauge reaches 10 inches Hg) may not contain enough sample volume to meet sample volume requirements for high-resolution GC/MS analysis detection limits.

Summa canisters do not require any special storage procedures (e.g., no chilling). Ice crystals can block the flow controller or sampling apparatus at temperatures at or below freezing. Frequent monitoring of canister pressure is recommended during cold periods.

### 7.0 References

U.S. Environmental Protection Agency. 1999. *Compendium of Methods for the Determination of Toxic Organic Compounds in Ambient Air*, Second Edition, *Compendium Method TO-15, Determination of Volatile Organic Compounds (VOCs) in Air Collected in Specially Prepared Canisters and Analyzed by Gas Chromatography/Mass Spectrometry (GC/MS)*. January.

Eurofins/Air Toxics, 2014. *Guide to Air Sampling - Canisters and Bags*. June.

**Tap Water Sampling**

SOP 1-9

Revision: 7

Date: February 2015

Approved:

  
Signature

Technical Review:

David Sembrot

**1.0 Objective**

The objective of this technical standard operating procedure (SOP) is to define the requirements for collecting tap water samples for the purpose of assessing water quality. General guidelines for purging the water supply system before sample collection are also provided. Depending on the objective of the sampling event as defined in the site-specific sampling plan, the water source may be from a private or public potable water supply, such as a groundwater well or a surface water reservoir.

**2.0 Background****2.1 Definitions**

**Holding Tank** - An in-house water reservoir that provides a limited reserve water supply and equalizes water pressure throughout the plumbing system. Most domestic well holding tanks have a storage capacity of approximately 30 gallons.

**Onsite Water Supply** - A source of potable water located on the property to be sampled. The water source could be a groundwater aquifer (i.e., a residential groundwater well) or a surface water body (i.e., a water intake from a lake).

**Potable Water** - Water considered safe for human consumption.

**Tap Water Samples** - Samples of water collected from a faucet or spigot at a residence, business, or industrial plant. Usually, samples are collected from the tap(s) nearest the water supply source or area of interest along the distribution system.

**Water Filter** - A device used to remove suspended particulate matter and/or various compounds from the water source. One type of common filter is a water softener that uses a calcium-salt filter to remove calcium and magnesium ions from potable water to reduce the hardness.

**2.2 Associated Procedures**

- SOP 1-2, *Sample Custody*
- SOP 2-1, *Packaging and Shipping Environmental Samples*
- SOP 4-1, *Field Logbook Content and Control*
- SOP 4-3, *Well Development and Purging*
- SOP 4-5, *Field Equipment Decontamination at Nonradioactive Sites*

**2.3 Discussion**

Tap water sampling may be conducted in residential, commercial, or industrial areas. Consequently, sampling personnel will interface with the general public (i.e., homeowners, business owners, or concerned citizens) and must present themselves in the utmost professional manner. Permission to access the property must be obtained before conducting the tap water sampling event; the client shall be consulted as to the proper notification procedures. At the time of the sampling, it is recommended that a letter of introduction be presented to the property owner or representative, explaining the purpose of the tap water sampling and indicating the name of the person and phone number to contact if the property owner has questions. At no time shall the sampling team enter a home or business without the approval of the property owner; the property owner or representative must be present to enter a building.

Generally, water supply sources and distribution systems can be categorized into two types:

- Onsite water supplies such as private, groundwater wells or surface water intakes for single residences, businesses, or industrial plants with limited distribution systems

## Tap Water Sampling

SOP 1-9

Revision: 7

Date: February 2015

- Large distribution systems from public or municipal groundwater or surface water supplies with extensive distribution systems for multiple users

The site-specific sampling plan shall describe the source of the potable water supply, the water distribution system, and other site-specific factors that may affect the water quality (well construction details, local hydrogeology, the presence of filters or holding tanks within the distribution system, pipe age, and composition, etc.). It is preferable to collect the samples from a tap located prior to a filtering device or a holding tank so that contaminants will be less likely to have been removed or allowed to settle out. The sampling objectives and sampling requirements, including analytical parameters, preservatives, and sample handling procedures must also be specified. Depending on the water source and distribution system, the site-specific sampling plan shall describe the requirements for purging the system before collecting the tap water sample and for disposing of the purged water.

The procedures described in this SOP provide guidelines to obtain representative tap water samples from water supplies/distribution systems ranging from small onsite water supplies to large multiuser distribution systems.

### 3.0 General Responsibilities

**Field Team Leader** - The field team leader is responsible for ensuring that sampling efforts are conducted in accordance with this procedure and any associated SOPs.

**Sampling Personnel** - Field team members are responsible for conducting tap water sampling events in accordance with this procedure, all associated SOPs, and requirements as described in the site-specific plans.

**Note:** Responsibilities may vary from site to site. Therefore, all field team member responsibilities shall be defined in the field plan or site/quality assurance project plan (QAPP).

### 4.0 Required Equipment

All or part of the equipment listed may be required at any specific site, depending on the plan(s) for that site.

- Site-specific plans including letter(s) of introduction
- Field logbook and indelible black ink pens and markers
- Forms and other documentation for sample shipment
- Sample containers, labels, and preservatives, as required
- Insulated cooler and waterproof sealing tape
- Ice bags or "blue ice"
- Plastic zip-top bags
- 5-gallon bucket and stopwatch
- Temperature, conductivity, pH, dissolved oxygen, and turbidity meters (with clean beakers or other appropriate containers), as required by the site-specific plans
- Photoionization detector (PID) and/or other monitoring/screening instruments as required by the site-specific health and safety plan or sampling plan
- Decontamination supplies, as required by SOP 4-5
- Personal protective equipment (PPE), as required by the site-specific health and safety plan
- Latex or appropriate gloves

### 5.0 Procedures

1. Obtain the name(s) of the resident(s) or water supply owner/operator, the exact mailing address, and telephone numbers. This information is required to obtain access to the property to be sampled and to submit a letter of introduction to the owner/representative.

## Tap Water Sampling

SOP 1-9

Revision: 7

Date: February 2015

2. Determine the location of the tap to be sampled based on its proximity to the water source. It is preferable that the tap being sampled be prior to any holding or pressure tanks, filters, water softeners, or other treatment devices that may be present.
3. If the sample must be collected at a point in the water line beyond a pressurization or holding tank, a sufficient volume of water shall be purged to provide a complete exchange of fresh water into the tank and at the location where the sample is collected. If the sample is collected from a tap or spigot located just before a storage tank, spigots located inside the building or structure shall be turned on to prevent any backflow from the storage tank to the sample tap or spigot. It is generally advisable to open as many taps as possible during the purge, to ensure a rapid and complete exchange of water in the tanks.
4. Samples collected to determine if system related variables (e.g., transmission pipes, water coolers/heaters, holding/ pressurization tanks) are contributing to the quality of potable water shall be collected after a specific time interval (e.g., weekend, holiday). Sample collection shall consist of an initial flush, a sample after several minutes, and another sample after the system has been purged.
5. Devices such as hoses, filters, or aerators attached to the tap may harbor a bacterial population and therefore shall be removed before sampling.
6. Potable water samples which have been chlorinated must be treated with sodium thiosulfate to dechlorinate the sample prior to other preservation and shipping for analysis.
7. Sample containers shall not be rinsed before use when sampling for bacterial content, and precautions shall be taken to avoid splashing drops of water from the ground or sink into either the bottle or cap.
8. Samples of the raw water supply and the treated water after chlorination shall be collected when sampling at a water treatment plant.
9. In the logbook, record the location and describe the general condition of the tap selected for sampling. The rationale used in selecting the tap sampling location, including any discussions with the property owner, shall also be recorded. Provide a sketch of the water supply/distribution system noting the location of any filters or holding tanks and the water supply source (i.e., an onsite groundwater well or surface water intake or a water service line from a public water main). If an onsite water supply is present, observe and record the surrounding site features that may provide potential sources of contamination to the water supply.
10. Don the appropriate personal protective clothing as dictated by the site-specific health and safety plan. Latex gloves shall be changed between sampling locations to avoid possible cross contamination of the tap water samples.
11. Before sample collection, the supply system shall be purged by turning the cold water tap on. The following general guidelines shall be followed to determine when the system is adequately purged (refer to the site-specific sampling plans for any other requirements):
  - **Onsite Water Supply.** A minimum of three standing volumes of water (i.e., the static volume of water in the well and holding tank, if present) shall be purged. Obtain water temperature, conductivity, and pH measurements after each volume of water is purged. If the standing volume of water in the supply system is unknown, the tap shall be allowed to run for a minimum of 15 minutes and temperature, conductivity, and pH measurements, or other parameters as specified by the project plan, shall be collected at approximately 3- to 5-minute intervals. (In general, well construction details and holding tank volumes shall be obtained before conducting the sampling event to estimate the standing volume of the water supply system.) The system is considered adequately purged when the temperature, conductivity, and pH stabilize within 10 percent for three consecutive readings. If these parameters do not stabilize within 15 minutes, then purging shall be discontinued and tap water samples may be collected as discussed in Section 6.0.

## Tap Water Sampling

SOP 1-9

Revision: 7

Date: February 2015

- **Large Distribution Systems.** Because it is impractical to purge the entire volume of standing water in a large distribution network, a tap shall be run for a minimum of 5 minutes, which shall be adequate to purge the water service line. Obtain temperature, conductivity, and pH measurements at approximately 1-minute intervals. The system is considered adequately purged when the temperature, conductivity, and pH readings, or other parameters as specified by the project plan, stabilize within 10 percent for three consecutive readings. If these parameters do not stabilize within 5 minutes, then purging shall be discontinued and tap water samples may be collected as discussed in Section 6.0.

During purging, a 5-gallon bucket and stopwatch may be used to estimate the flow rate if required by the site-specific plans. Dispose of the purged water according to the site-specific plans. Record the temperature/conductivity/pH readings, or other parameters as specified by the project plan, the volume of water purged, the flow rate if measured, and the method of disposal in the field logbook.
- 12. After purging the supply system, collect the samples directly from the tap (i.e., if a hose was used for purging, the hose shall be disconnected before sampling). Any fittings on the end of the faucet that might introduce air into the sample (i.e., a fine mesh screen that is commonly screwed onto the faucet) shall be removed before sample collection also.
- 13. Obtain a smooth-flowing water stream at moderate pressure with no splashing. Samples for volatile organic compound (VOC) analyses shall be collected using a reduced flow rate (see below). Hold the sample bottle in one hand and the cap in the other; do not touch the inside of the cap; do not allow the faucet to touch the inside of the bottle; do not allow splashing water from the ground or sink to enter the bottle or cap. VOC samples shall be filled first, followed by other organic analyses, inorganic analyses, and then other water quality parameters. Refer to the site-specific plans for the required sample parameters, preservatives, and sample handling procedures. The following general guidelines shall be followed when collecting samples:
  - **VOC.** Reduce the flow rate to a minimum to reduce aeration of the VOC sample. Use a pre-preserved “test” vial to determine the appropriate amount of hydrochloric acid (HCl) needed to reduce the pH of the sample to less than 2. Dispose of this test vial after the appropriate amount of HCl is determined. Add the required amount of HCl to the sample vials and then fill the vials with the sample water. Quickly replace the cap and check for air bubbles. If air bubbles are present, the vial will be discarded and a new vial will be filled as detailed above.
  - **Semivolatile Organic Compounds (SVOCs), Pesticides, and Polychlorinated Biphenyls (PCBs).** Generally, aqueous samples for SVOCs and pesticides/PCBs require no preservative. Sample containers may be filled directly from the tap.
  - **Total (unfiltered) Metals.** Generally, tap water samples are not collected for filtered (dissolved) metals because risk assessment data needs require total metals analyses (check the site-specific plans to determine filtering requirements). The sample container for total metals may be filled directly from the tap. Nitric acid (HNO<sub>3</sub>) shall then be added to the filled container to preserve the sample to a pH less than 2.
  - **Other Sample Parameters.** Other water quality parameters, such as cyanide dissolved oxygen, hardness, nitrate/nitrite, etc., shall be collected and preserved as required by the site-specific sampling plans.
- 14. Label all sample containers as required and place them in a cooler with ice. Record all appropriate data in the field logbook and on the chain-of-custody forms.

### 6.0 Restrictions/Limitations

To protect the sample from contamination on the exterior of a tap, a tap shall not be chosen for sampling if any of the following conditions exist:

- A leaky tap allowing water to flow out from around the stem of the valve handle and down the outside of the faucet.
- A tap located too close to the bottom of the sink or the ground surface.
- A tap that allows water to run up on the outside of the lip.

## Tap Water Sampling

SOP 1-9

Revision: 7

Date: February 2015

- A tap that does not deliver a steady stream of water. A temporary fluctuation in line pressure may cause sheets of microbial growth, lodged in some pipe sections or faucet connections, to break loose.

Careful sampling for VOC analysis, or for any other compound(s) that may be degraded by aeration, is necessary to minimize sample disturbance and, hence, analyte loss.

### 7.0 References

U. S. Environmental Protection Agency. 2013. Region 4. The Field Branches Quality System and Technical Procedures, Potable Water Sampling. SESDPROC-305-R3. May.



**Field Measurement of Total Organic Vapors**

SOP 1-10

Revision: 7

Date: February 2015

Approved:

  
Signature

Technical Review:

Stuart Barden

**1.0 Objective**

The objective of this technical standard operating procedure (SOP) is to define the techniques and the requirements for the measurement of total organic vapors in the field.

**2.0 Background****2.1 Definitions**

**Photoionization Detector (PID)** - A portable, hand-held instrument that measures the concentration of gaseous organic compounds through the photoionization of organic vapors.

**Flame Ionization Detector (FID)** - A portable, hand-held instrument that measures the concentration of gaseous organic compounds through the flame ionization of organic vapors.

**2.2 Associated Procedures**

- SOP 1-4, *Subsurface Soil Sampling*
- SOP 1-5, *Groundwater Sampling Using Bailers*
- SOP 1-6, *Water Level Measurement*
- SOP 1-8, *Volatile Organic Compound Air Sampling Using USEPA Method TO-15 with SUMMA Canister*
- SOP 1-12 *Low-Stress (Low-Flow) Groundwater Sampling*
- SOP 3-1, *Geoprobe® Sampling*
- SOP 3-5, *Lithologic Logging*
- SOP 4-3, *Well Development and Purging*

**2.3 Discussion**

The measurement of organic vapors is a required step during numerous field activities. The primary purpose of such measurements is health and safety monitoring to determine if the breathing zone in a work area is acceptable or if personal protective equipment such as a respirator or a supplied air device is necessary for field personnel. At the perimeter of a work area, measurements can be taken as part of a perimeter air monitoring plan to document protection of surrounding community. In addition to health and safety monitoring, total organic vapor measurement is also used in conjunction with sampling activities, including screening subsurface soil samples, soil vapor and indoor air sampling, and groundwater sampling, where measurements are useful for establishing approximate contaminant levels or ranges.

The two types of instruments most commonly used to measure total organic vapors are PIDs and FIDs. Both instruments first ionize the gaseous compound and then measure the response, which is proportional to the concentration.

**2.3.1 PID Operation**

The PID is preferred when the compound of interest is an aromatic or halogenated volatile organic compound (VOC). The PID ionizes the sampled vapors using an ultraviolet lamp that emits light energy at a specific electron voltage (eV - labeled on the lamp). The ultraviolet lamp produces photons that are absorbed by the sampled vapor molecule. The molecule becomes excited, producing a positively charged ion and emitting an electron. The number of electrons emitted is proportional to the concentration of the sampled gases. Every organic compound has a specific ionization potential in electron volts. The energy emitted by the lamp must be higher than the ionization potential of the compound for the compound to become ionized and emit an electron. If the ionization potential of the compound is higher than the eV of the lamp, there will be no response on the instrument. Therefore, the ionization potential of the known or suspected compounds shall be checked against the energy of the ultraviolet lamp to verify that the energy provided by the lamp is greater. The manufacturer's manual shall be consulted to determine the appropriate ultraviolet lamp to be used for the known or suspected compounds. Additionally, manufacturer's manuals shall be consulted to obtain the appropriate correction factors for known or suspected contaminants.

## Field Measurement of Total Organic Vapors

SOP 1-10

Revision: 7

Date: February 2015

Water vapor in the vapor sample can interfere with the PID detector and cause the instrument to stop responding or cause the zero baseline to drift. This can occur using the PID on a rainy day or when sampling headspace samples that have been in the sun. If moisture interference is suspected, the calibration gas shall be used to check the instrument response by inserting the gas as a check sample, not by recalibrating. If the response is lower than the gas level, then the probe and the ionization chamber shall be dried out before reusing the instrument.

The sampling probe shall not be inserted directly into soil samples or dusty areas, as the instrument vacuum will pull dirt into the ionization chamber. Under particularly dirty or dusty conditions, the lamp may become covered with a layer of dust. If dirty conditions are encountered, or if the instrument response seems to have decreased, then the lamp shall be cleaned. The instrument manual provides instructions on how to remove the instrument cover to access the lamp, and how to clean the screen in the ionization chamber and the surface of the lamp.

The instrument manual may provide instruction on use of disposable dust and/or moisture filters for minimizing effects from dust and/or moisture.

The ultraviolet lamp in the PID is sensitive to shock, especially when using the higher eV lamps. Therefore, they shall be handled and transported carefully.

### 2.3.2 FID Operation

The FID is preferred when sampling for petroleum hydrocarbons and methane (landfill gases). It responds well to aromatic hydrocarbons but is not as convenient to use as the PID. The FID allows measurement of a wide variety of compounds, but in general its sensitivity is not as high as the PID for compounds where the PID is applicable. The FID is virtually unaffected by ambient levels of water vapor.

The FID ionizes the vapor sample by burning it in a hydrogen/air flame, and measuring the response beyond what is caused by the hydrogen alone. This instrument requires a hydrogen supply, contained in a small tank in the instrument. This hydrogen, including the gas in the instrument tank, is considered a flammable gas and appropriate requirements must be adhered to when shipping. The instrument shall be emptied of hydrogen before shipping. Federal Express Hazardous Material shipping manifests must be completed when shipping the gas.

The hydrogen gas in the FID combustion chamber is ignited by pressing a red button on the side of the instrument, which sends electrical current to a small resistance coil igniter in the combustion chamber. This igniter is very sensitive, and if the red button is pressed for longer than 5 seconds, the coil will burn out and the instrument will be unusable unless another igniter is available. If the instrument will not light, check the electrical connections and switches for proper settings. Check that the pump is pumping, and allow fresh air to flow through the combustion chamber for several minutes before lighting. Check to see if the exhaust port of the combustion chamber is dirty.

## 3.0 Responsibilities

**Site Manager** - The site manager is responsible for ensuring that field activities are conducted in accordance with this procedure and any other SOPs pertaining to the specific activity.

**Field Team Leader** - The field team leader is responsible for ensuring that field personnel conduct field activities in accordance with this and other relevant procedures.

**Note:** Responsibilities may vary from site to site. Therefore, all field team member responsibilities shall be defined in the field plan or site-/project-specific quality assurance plan.

**Field Measurement of Total Organic Vapors**

SOP 1-10

Revision: 7

Date: February 2015

**4.0 Required Equipment**

- Site-specific plans (i.e., scope of work)
- Health and safety plan
- Field logbook
- Waterproof black ink pen
- Personal protective clothing and equipment
- Photoionization detector or flame ionization detector
- Calibration gases in a range appropriate for the expected use
- 0.5 liter (16-ounce) or “Mason” type glass jar or Ziploc-type plastic bags
- Hydrogen canister and fill valve and hose (if using FID for a period of more than 1 day)

**5.0 Procedures****5.1 Direct Reading Measurement**

1. Connect the measurement probe to the instrument and make necessary operational checks (e.g., battery check, etc.) as outlined in the manufacturer’s manual.
2. Calibrate the instrument following the applicable manufacturer’s manual
3. Make sure the instrument is reading zero and all function and range switches are set appropriately.
4. Insert the end of the probe directly into the atmosphere to be measured (e.g., breathing zone, monitoring well casing, split spoon, etc.) and read the total organic vapor concentration in parts per million (ppm) from the instrument display. Apply the appropriate correction factor if necessary. Record the highest instrument response.
5. Immediately document the reading in the field logbook or on the appropriate field form.

**5.2 Headspace Measurement**

1. Connect the measurement probe to the instrument and make necessary operational checks (e.g., battery check, fan check, etc.) as outlined in the manufacturer’s manual.
2. Calibrate the instrument following the appropriate manufacturer’s manual.
3. Make sure the instrument is reading zero and all function and range switches are set appropriately.
4. Fill a clean glass jar or Ziploc-type plastic bag approximately half-full of the sample to be measured. For a jar, quickly cover the top of the jar with one or two sheets of clean aluminum foil and apply cap to seal the jar. For a bag, quickly seal the bag minimizing volume of air in bag.
5. Allow headspace to develop for approximately 10 minutes. It is generally preferable to shake the sealed jar for 10 to 15 seconds at the beginning and end of headspace development. For a bag, kneed the bag to break apart the sample and maximize sample surface area.

**Note:** When the ambient temperature is below 0°C (32°F), the headspace development and subsequent measurement shall occur within a heated vehicle or building.

6. For a jar, remove the jar cap and quickly puncture the foil and insert the instrument probe to a point approximately one-half of the headspace depth. Do not let the probe contact the soil. For a bag, quickly puncture the bag wall and insert the probe, wrapping the bag wall around the probe stem to minimize loss of vapors. If using a PID and there is condensation on the inside of the jar or bag, only leave the probe in the jar or bag long enough to obtain a reading. Remove the probe and allow fresh air to flow through the instrument to avoid excess water vapor to build up.

## Field Measurement of Total Organic Vapors

SOP 1-10

Revision: 7

Date: February 2015

7. Read the total organic vapor concentration in ppm from the instrument display. Apply the appropriate correction factor if necessary. Record the highest instrument response.
8. Immediately record the reading in the field logbook or on the appropriate field form.

### 6.0 Restrictions/Limitations

The two methods outlined above are the most commonly used for field measurement of total organic vapors but do not apply to all circumstances. Consult project- or program-specific procedures and guidelines for deviations. Both the PID and FID provide quantitative measurement of total organic vapors, but generally neither instrument is compound-specific. The typical reading range of the PID is 0 to 2,000 ppm, and the typical reading range of the FID is 0 to 10,000 ppm. The FID will measure methane while the PID will not. **Note:** The presence of methane will cause erratic PID measurements. In methane rich environments, toxic organic vapors shall be monitored with an FID. If desired, a charcoal filter can be placed temporarily on the FID inlet probe, which will trap all organic vapors except methane. The filtered (methane only) reading can be subtracted from unfiltered (total organic vapors) to provide an estimate of non-methane organic vapors. The reading accuracy of both instruments can be affected by ambient temperature, barometric pressure, humidity, lithology, etc.

### 7.0 References

Department of Defense. *Environmental Field Sampling Handbook, Revision 1*. April 2013 or current revision.

**Sediment and/or Sludge Sampling**

SOP 1-11

Revision: 10

Date: February 2015

Approved:

  
Signature

Technical Review:

Stuart Barden

**1.0 Objective**

The purpose of this technical standard operating procedure (SOP) is to define requirements for collection and containment of samples collected from freshwater or marine sediment, and/or sludge samples.

**2.0 Background****2.1 Definitions**

**Sediment** - Bottom substrate underlying a body of surface water, whether freshwater or marine, such as a lake pond, harbor, river, bay or other surface water bodies.

**Sludge** - Bottom substrate underlying an engineered wastewater pond or solid material removed from a wastewater treatment stream or effluent. Sludge materials range in type from dewatered solids to high viscosity liquids. Sludge particles may be suspended throughout the water column or settled to the bottom as the bottom substrate.

**Grab Sample** - A surface sample from the sediment or sludge taken from a specific location at a given point in time. Used for horizontal characterization of sediment or sludge.

**Core Sample** - A subsurface sample taken from the sediment or sludge using a coring device that allows for penetration to a greater vertical depth; used for more comprehensive, vertical characterization of sediment or sludge.

**Composite** - Two or more subsamples taken from the sediment or sludge at a specific location at a specific point in time, which are then combined and homogenized (mixed) to form a single sample when removed from the homogenate.

**Discrete** - An individual sample that is taken from the sediment or sludge and analyzed as an individual sample, rather than combined or homogenized to create a composite sample.

**2.2 Associated Procedures**

- SOP 1-2, *Sample Custody*
- SOP 2-1, *Packaging and Shipping Environmental Samples*
- SOP 4-1, *Field Logbook Content and Control*
- SOP 4-2, *Photographic Documentation of Field Activities*
- SOP 4-5, *Field Equipment Decontamination at Nonradioactive Sites*

**2.2 Discussion**

Sediment/sludge samples are collected to physically, chemically, and/or biologically characterize the nature of the substrate within a given surface water body. Sediment and sludge samples offer the advantage over surface water samples that they provide a more stable, site-specific, and possibly historical account of contamination or other features than surface water samples, as surface water may be flowing, is transitory, and thus more difficult to ascribe specific characteristics to any given specific location.

## Sediment and/or Sludge Sampling

SOP 1-11

Revision: 10

Date: February 2015

### 3.0 General Responsibilities

**Site Manager** - The site manager is responsible for ensuring that field personnel are trained in the use of this and related SOPs and the required equipment.

**Field Team Leader** - The field team leader (FTL) is responsible for ensuring that sampling efforts are conducted in accordance with this procedure and any other specific SOPs pertaining to specific sample collection requirements. The FTL must also ensure that the quantity, locations, and procedures for collecting sediment/sludge sampling meet the requirements of any approved site-specific plans such as sampling and analysis plans (SAPs), field sampling plans (FSPs), and quality assurance project plans (QAPPs).

**Note:** Responsibilities may vary from site to site. Therefore, all field team member responsibilities shall be defined in the field sampling plan and/or site quality assurance project plan (QAPP).

### 4.0 Required Equipment

All or part of the equipment listed under the “as needed” category may be required at any specific site, depending on the plan(s) for that site.

- Site-specific plans
- Field logbook
- Indelible black ink pens and markers
- Labels and appropriate forms/documentation for sample shipment
- Appropriate sample containers
- Insulated cooler and waterproof sealing tape
- Ice bags or “blue ice”
- Plastic zip-top bags
- Clear waterproof tape
- Personal protective clothing and equipment (e.g. hard hat, etc.)
- Latex or other appropriate gloves, boots
- Rubber boots and/or rubberized waders
- Stainless steel or Teflon® spoons, spatulas, or scoops
- Teflon or stainless steel mixing bowls or trays
- Aluminum foil
- Kimwipe or paper towels
- ½- to ¾-inch (12- to 19-mm) braided nylon line or Teflon-coated wire rope
- Clean plastic sheeting
- Tap and deionized water with spray bottles
- Appropriate photographic equipment and supplies
- Appropriate decontamination equipment and supplies (e.g. detergent, scrub brushes, buckets for capturing investigation-derived waste)
- Eckman, Ponar, Van Veen, or other grab sampling device for depositional area (e.g. stream) sediment or lake sampling
- Chain of Custody forms from laboratory(ies) as appropriate

#### As needed:

- Global Positioning System (GPS) unit
- Hand or gravity corer with extensions or stainless steel hand auger
- Core liners of Teflon, stainless steel, brass, aluminum, or polybutyrate, as specified in the site-specific plan(s)
- Stainless steel push tubes
- Dredge with 15- to 20-foot (4.5- to 6.0-meter) sampling pole (hollow) and insert (e.g., Peterson, Eckman, Ponar)
- Motorized or other coring device
- Boat with depth finder for deep water or inaccessible shorelines
- Any personal protective equipment specified in the site-specific health and safety plan
- Spare parts for all equipment
- Tape measure

**Sediment and/or Sludge Sampling**

SOP 1-11

Revision: 10

Date: February 2015

**5.0 Procedures****5.1 Preparation**

The following steps shall be taken when preparing for sampling sediment/sludge:

1. Review site-specific health and safety plan (HSP) and project plans (FSP, QAPP) before initiating sampling activity.
2. Don the appropriate personal protective clothing as described by the HSP.
3. Use field GPS unit to identify selected sediment or sludge samples within the specified tolerance (e.g. within 2 meters, etc.).
4. Where specific locations are unspecified in the project plans, within a stream or river, avoid areas where the channel has been scoured or where bedrock is present, as it may not be possible to collect samples at these locations.
5. Where excessive organic materials (e.g., root mass, leaf litter) or large grain sizes (e.g. medium to coarse gravel) are present, these material should be minimized in the collected sample.
6. Prepare sampling site by laying out clean plastic sheeting on the ground or any flat, level surfaces near the sampling area and place equipment to be used on the plastic.
7. If surface water is present at the sample location, make field measurements in physical, chemical, and biological characteristics of the water (e.g., temperature, dissolved oxygen, conductivity, pH, etc.), as described by the project-specific plans.
8. The samples shall be collected from areas of least to greatest contamination (when known) and, when collecting several samples in one day in a flowing water body, should be always collected from downstream to upstream.
9. When sampling sediment and surface water from the same surface water body, collect surface water samples before sediment samples to avoid collection of resuspended sediment or sludge particulates.
10. Document the sampling events, recording all information in the designated field logbook and take photographs (as appropriate). Document any and all deviations from this SOP in the field notebook and include rationale for changes.
11. The sample collection points should be shown on a site map and described in the field logbook; any deviations from the site plans should be documented, as well as the rationale for this deviation.
12. Label each sample container with the appropriate information. Secure the label by covering it with waterproof clear tape.
13. Decontaminate reusable sampling equipment after sample collection according to SOP 4-5.
14. Procedures for verifying depths of samples must be included in site-specific project plans.
15. Check that a trip blank/temperature blank, when necessary, is included in the chilled cooler. Quality assurance/quality control requirements vary from project to project. Consult the project-specific work plan for quality requirements.

**5.2 Sediment/Sludge Sample Collection from Shallow Waters****5.2.1 Method for Collecting Samples for Volatile Organic Compound (VOC) Analysis**

The following steps must be followed when collecting shallow water sediment/sludge VOC samples:

**Sediment and/or Sludge Sampling**

SOP 1-11

Revision: 10

Date: February 2015

1. Use a decontaminated stainless steel or Teflon, long-handled scoop, corer, push tube, or dredge to collect the entire sample in one grab. If wading is necessary, approach the sample location from downstream. Do not enter the actual sample area.
2. Retrieve the sampling device and slowly decant off any liquid phase.
3. Immediately fill the specified sample container(s) with the solid. Use a clean stainless steel or Teflon spoon or spatula to completely fill the container(s), ensuring no headspace.

**Note:** Samples to be analyzed for VOC or other compounds degraded by aeration shall be taken as grab samples. Do not homogenize or composite these samples.

4. Once each container is filled, close the container with the Teflon-lined cap. Wipe the outside of the container clean with a Kimwipe or clean paper towel. Affix a completed sample label.
5. Place the sample container(s) in individual zip-top plastic bags and seal the bags.
6. Immediately pack all samples into a chilled cooler.

**5.2.2 Method for Collecting Samples for Non-volatile, Semi-Volatile Organic and Inorganic Compound Analysis**

The following steps must be taken when collecting shallow water sediment or sludge samples for analytes not immediately degraded by aeration:

1. Collect sufficient volume to fill specified sample containers using decontaminated stainless steel or Teflon-lined equipment (scoops, corer, dredge sampler, etc.). If wading is necessary, approach the sample location from downstream. Do not enter the actual sample area.
2. Retrieve the sampling device with the sample and slowly decant off any liquid phase.
3. Pool and homogenize samples in a stainless steel, Teflon, or appropriate pan or mixing bowl, using stainless steel spatula or spoon.
4. Fill each sample container with the homogenized sample to approximately 75 to 90 percent capacity, filling sample containers for organics analyses first.
5. Once each container is filled, close the container with a Teflon-lined cap. Wipe the outside of sample containers clean with a Kimwipe or clean paper towel. Affix a completed sample label.
6. Place the sample container(s) in individual zip-top plastic bags and seal the bags.
7. Immediately pack all samples into a chilled cooler, if required for preservation.

**5.3 Subsurface Sediment/Sludge Sample Collection Using a Corer or Auger from Shallow Waters****5.3.1 Method for Collecting Samples for Volatile Organic Compound Analysis Using an Unlined Corer (also applies to augers)**

The following steps must be taken when collecting subsurface sediment or sludge VOC samples that underlie shallow water:

1. At the specified sampling location, force or drive the corer to the specified depth.



**Sediment and/or Sludge Sampling**

SOP 1-11

Revision: 10

Date: February 2015

2. Twist and withdraw the corer in a smooth motion.
3. Retrieve the sampling device, remove the corer nosepiece (if possible), and extrude the sample into the specified sampling container(s). Use a clean stainless steel or Teflon spoon or spatula to completely fill the container(s), ensuring no headspace.
4. Once each container is filled, close the container with the Teflon-lined cap. Wipe the outside of the sample container clean with a Kimwipe or clean paper towel. Affix a completed sample label.
5. Place the sample container(s) in individual zip-top plastic bags and seal the bags.
6. Immediately pack all samples into a chilled cooler.

**5.3.2 Method for Collecting Samples for Volatile Organic Compound Analysis Using a Lined Corer**

The following steps must be followed when collecting shallow water subsurface sediment/sludge VOC samples that underlie shallow water:

1. Install decontaminated liner(s) in the corer barrel.
2. At the specified sampling location, force or drive the corer to the specified depth.
3. Twist and withdraw the corer in a smooth motion.
4. Retrieve the sampling device, remove the corer nosepiece (if possible) and remove the liner(s), cap the liner(s), and seal the caps with Teflon tape.
5. Wipe the outside of the liner clean with a Kimwipe or clean paper towel. Label the top and bottom ends of the liner(s). Affix a completed sample label.
6. Place capped and sealed liners in individual zip-top plastic bags and seal the bags.
7. Immediately pack all samples into a chilled cooler.

**5.3.3 Method for Collecting Samples for Non-volatile, Semi-Volatile Organic and Inorganic Compound Analysis Using a Corer (also applies to augers)**

The following steps must be followed when collecting subsurface sediment/sludge samples that underlie shallow water for analytes not degraded by aeration:

1. At the specified sampling location, force or drive the corer to the specified depth.
2. Twist and withdraw the corer in a smooth motion.
3. Retrieve the sampling device. Remove the corer nosepiece (if possible) and extrude the sample into a stainless steel or Teflon-lined pan or bowl. Collect sufficient sample volume to fill all containers.
4. Use a stainless steel or Teflon spoon or spatula to homogenize and then divide the sample material into the appropriate number of sample containers.

**Sediment and/or Sludge Sampling**

SOP 1-11

Revision: 10

Date: February 2015

5. Fill each container to approximately 75 to 90 percent capacity, filling containers for organics analyses first. Close the container with a Teflon-lined cap. Wipe the outside of sample containers clean with a Kimwipe or clean paper towel. Affix a completed sample label.
6. Place the sample container(s) in individual zip-top plastic bags and seal the bags.
7. Immediately pack all samples into a chilled cooler.

**5.4 Sediment or Sludge Sample Collection Using a Dredge (Grab) Sampler from Deeper Waters****5.4.1 Method for Collecting Samples for Volatile Organic Compound Analysis**

The following steps must be followed when collecting deep-water sediment/sludge VOC samples:

1. Attach a clean piece of ½- to ¾-inch (12- to 19-mm) braided nylon line or Teflon-coated wire rope to the top of the dredge sampler. The line must be of sufficient length to reach the sediment or sludge and have enough slack to release the mechanism. Mark the distance to the bottom on the line.
2. Attach the free end of the sampling line to a fixed support to prevent loss of the sampler.
3. At the specified sampling location, open the sampler jaws and slowly lower the sampler until contact with the bottom (sediment/sludge) is felt.
4. Release tension on the line; allow sufficient slack for the mechanism (latch) to release. Slowly raise the sampler to reduce disturbance of the sampler to the extent possible.
5. Once the sampler is above the water surface, place the sampler in a stainless steel or Teflon-lined tray or pan. Open the sampler. Immediately collect the sample for VOC analysis, using a stainless steel or Teflon spoon or spatula. Fill each container completely to minimize headspace.
6. Once each container is filled, close the container with the Teflon-lined cap. Wipe the outside of sample containers clean with a Kimwipe or clean paper towel. Affix a completed sample label.
7. Place the sample container(s) in individual zip-top plastic bags and seal the bags.
8. Immediately pack all samples into a chilled cooler.

**5.4.2 Method for Collecting Samples for Non-volatile, Semi-volatile Organic and Inorganic Compounds**

The following steps must be followed when collecting deep-water sediment/sludge samples for analytes not degraded by aeration:

1. Attach a clean piece of ½- to ¾-inch (12- to 19-mm) braided nylon line or Teflon-coated wire rope to the top of the sampler. The line must be of sufficient length to reach sediment or sludge and have enough slack to release the mechanism. Mark the distance to the bottom on the line.
2. Attach the free end of the sampling line to a fixed support to prevent loss of the sampler.
3. At the specified sampling location, open the sampler jaws and slowly lower the sampler until contact with the bottom (sediments/sludge) is felt.
4. Release tension on the line; allow sufficient slack for the mechanism (latch) to release. Slowly raise the sampler to reduce disturbance of the sampler to the extent possible.

**Sediment and/or Sludge Sampling**

SOP 1-11

Revision: 10

Date: February 2015

5. Once the sampler is above the water surface, place the sampler in a stainless steel or Teflon-lined tray or pan. Open the sampler.
6. Collect sufficient volume of sample to fill the specified sampler containers, and place the material into a clean stainless steel bowl or other container to homogenize the sample. If compositing is required, pool the grab samples in a tray or other container, and homogenize the pooled samples by mixing them together with a stainless steel or Teflon spoon or spatula.
7. Fill the specified sample containers to approximately 75 to 90 percent capacity with the homogenized sample using the stainless steel or Teflon spoon or spatula. Fill sample containers for organics analyses first.
8. Once each container is filled, close the container with the Teflon-lined cap. Wipe the outside of sample containers clean with a Kimwipe or clean paper towel. Affix a completed sample label.
9. Place sample container(s) in individual zip-top plastic bags and seal the bags.
10. Immediately pack all samples into a chilled cooler.

**6.0 Restrictions/Limitations**

Core sampling devices may not be usable if cobbles exist in the sediment/sludge. Bumping of core sampling devices and Ponar dredge samplers may result in the loss of some of the sample.

Grab sampling for VOC analysis or for analysis of any other compound(s) that may be degraded by aeration is necessary to minimize sample disturbance and, hence, analyte loss. The representativeness of this sample, however, is difficult to determine because the collected sample represents a single point, is not homogenized, and has been disturbed.

**7.0 References**

Department of Defense. *Environmental Field Sampling Handbook, Revision 1*. April 2013 or current revision.

Mudroch, A. and S.D. MacKnight. 1991. *Handbook of Techniques for Aquatic Sediment Sampling*. CRC Press, Inc. 210 p.

U.S. Environmental Protection Agency, Region IV. *Science and Ecosystem Support Division, Operating Procedure SESDPROC-300-R3*. August 2014 or current revision.

U. S. Geological Survey. *National Field Manual for the Collection of Water-Quality Data*, Chapter A8. October 1997.

**Low- Stress (Low-Flow) Groundwater Sampling**

SOP 1-12

Revision: 2

Date: February 2015

Approved:

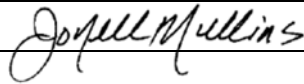

Technical Review:

Lynne France

**1.0 Objective**

The purpose of this technical standard operating procedure (SOP) is to define the procedural requirements for low-flow (minimal drawdown) groundwater sampling.

**2.0 Background**

Low-flow groundwater sampling is a method of collecting samples from a well that, unlike traditional purging methods, does not require the removal of large volumes of water from the well. The objective of low-flow groundwater sampling is to collect samples with minimal alterations to water chemistry through pumping the well at a rate low enough to minimize drawdown and to avoid disturbance in the well. Low-flow groundwater sampling refers to the velocity with which water enters the pump intake, and that which is imparted to the formation pore water in the immediate vicinity of the well screen. It does not necessarily refer to the flow rate of water discharged at the surface of the well which can be affected by flow regulators or restrictions.

Water level drawdown provides the best indication of the stress imparted by a given flow-rate for a given hydrological situation. The objective of low-flow groundwater sampling is to pump the well in a manner that minimizes stress (drawdown) to the system. Minimal drawdown must be stabilized such that the water to be sampled is representative of the formation surrounding the screened interval, and is not from the stagnant water column above the screened interval. Minimal drawdown is achieved to the extent practical taking site sampling objectives into account. Typically flow rates on the order of 0.1 to 0.5 liter per minute (L/min) are used. However, achieving flow rates of 0.1 to 0.5 L/min can be dependent on site-specific hydrogeology. Some very coarse-textured formations have successfully been sampled via low-flow techniques at flow rates up to 1 L/min. The effectiveness of using low-flow purging is intimately linked with proper well screen location, well screen length, and well construction and development techniques.

Low-flow groundwater sampling can be used to collect samples for all categories of aqueous-phase contaminants and naturally occurring analytes, including volatile organic compounds (VOCs), semivolatile organic compounds (SVOCs), and other organic compounds; metals and other inorganics; pesticides; polychlorinated biphenyls (PCBs); radionuclides; and microbiological constituents. Low-flow groundwater sampling techniques are particularly well-suited in applications where it is desirable to sample aqueous-phase constituents that may sorb or partition to particulate matter. It is not applicable to sampling wells that contain either light or dense non-aqueous-phase liquids (LNAPLs or DNAPLs).

A variety of sampling devices are available for low-flow groundwater sampling, including peristaltic pumps, bladder pumps, electrical submersible pumps, and gas-driven pumps. Pump type should be selected based on known site conditions, including well depth, well diameter, water level, and anticipated well volume, as well as sampling objectives. Note that peristaltic pumps (suction pumps) cannot be used under conditions in which the water table is greater than 25 feet below ground surface. Additionally, in most instances, peristaltic pumps may not be used for collecting VOC samples because they create a vacuum that potentially contributes bias to sampling for VOC's via low flow techniques. Bailers, too, are generally inappropriate devices for low-flow sampling. Gas-driven pumps are generally not advisable for VOC or SVOC sample collection due to the potential for sample contamination.

Dedicated pumps (those which are permanently installed in the well –e.g., bladder pumps) are preferred over portable pumps because they eliminate disturbance to the water column in the well during pump insertion, thus providing lower turbidity values, shorter purge times, and lower purge volumes to achieve stabilized indicator parameter measurements. However, portable pumps can be used if care is taken to minimize disturbance to the water column during pump insertion, and if adequate time is allowed following pump insertion and prior to pump operation for any particulates agitated in the water column to settle. Both dedicated and portable pumps should be easily adjustable, and should operate reliably at lower flow rates. All pumps typically have some limitations which should be evaluated with respect to site-specific considerations and data quality objectives on a case-by-case basis.

## Low- Stress (Low-Flow) Groundwater Sampling

SOP 1-12

Revision: 2

Date: February 2015

Water quality indicator parameters should be continuously monitored during low-flow purging using a flow-through cell, or in-line parameter monitoring techniques. Continuous indicator parameter monitoring is a critical component to low-flow groundwater sampling. Water quality indicator parameters include temperature, pH, oxidation-reduction potential (ORP), specific conductivity, dissolved oxygen (DO), and turbidity. The flow-through cell enables continuous collection of real-time parameters during low-flow purging. Stabilization is achieved after all parameters fall within established limits for three successive readings as discussed in Section 5. Stabilization of low-flow parameters is further discussed in Section 5.0 (Procedure) of this SOP.

Advantages of low-flow groundwater sampling are:

- Improved sample quality (e.g., less turbid and more representative of the aquifer)
- Potentially reduced purging and sampling times
- Reduced purge water volume

### 2.1 Associated Procedures

- SOP 1-6, *Water Level Measurement*
- SOP 4-5, *Field Equipment Decontamination at Nonradioactive Sites*
- SOP 2-2, *Guide to Handling of Investigation Derived Waste*

### 3.0 General Responsibilities

**Site Manager** - The site manager is responsible for ensuring that field personnel are trained in the use of this procedure and for verifying that well development and purging are carried out in accordance with this procedure.

**Field Team Leader** - The field team leader is responsible for complying with this procedure.

**Note:** Responsibilities may vary from site to site. Therefore, all field team member responsibilities shall be defined in the field plan or site-/project-specific quality assurance plan.

### 4.0 Required Equipment

- Pump (including peristaltic pumps, bladder pumps, electrical submersible pumps, and gas-driven pumps as discussed in Section 2.0 of this SOP)
- Appropriate controller for selected pump type
- For bladder pumps: Compressor and controller for the system (compressed non-reactive gas may also be used in lieu of a compressor)
- Power source (e.g., battery or generator), as required
- Pump tubing (typically polyethylene with Teflon® lining). Note that portable bladder pumps require combination tubing (for air and water); therefore the correct tubing sizes for the portable bladder pump should be verified. Additionally, peristaltic pumps require flexible tubing (silicone or Tygon) tubing for the pump head.
- Electronic water level meter or oil-water interface probe (according to SOP 1-6)
- Water quality meter (e.g., YSI 600 Series) with a closed flow-through cell for continuous in-line measurement of temperature, pH, conductivity, ORP, and DO prior to sample collection
- Turbidity meter (Reporting in nephelometric turbidity units [NTUs])
- Standards for calibration and field check, as needed, of water quality and turbidity meters (as determined by anticipated field conditions)
- Volume measuring device to determine flow (e.g., graduated cylinder)
- Stop watch
- Tape measure
- Personal protective equipment as specified in the site-specific health and safety plan
- Polyethylene sheeting

**Low- Stress (Low-Flow) Groundwater Sampling**

SOP 1-12

Revision: 2

Date: February 2015

- Sample containers, including packaging supplies and all associated paperwork (e.g., chain of custody forms) as required in the sampling plan and/pr SOP 2-1, Packaging and Shipping Environmental Samples
- Decontamination supplies, as required, according to SOP 4-5
- Disposal drums (e.g., 55-gallon Department of Transportation-approved) or other purge water storage container, if required by the site-specific sampling plan
- Photoionization detector (PID)/organic vapor monitor (OVM) or equivalent as specified in site-specific health and safety plan

**Note:** All sampling devices (bladders, pumps, and tubing) should be constructed of stainless steel, polyethylene, Teflon®, glass, or similar non-reactive materials.

**5.0 Procedure**

The following steps must be followed for low-flow groundwater sampling activities:

1. Review site-specific health and safety plan, and site-specific project and sampling plans before initiating sampling activities.
2. Review available existing data for site to evaluate approach to sampling site wells: prepare to sample site wells in the order of least contaminated to most contaminated. Additionally, existing site data should be reviewed to determine anticipated hydrogeologic conditions and well completion details.
3. Prior to sampling, all sampling devices and monitoring equipment shall be calibrated according to manufacturer's recommendations and the site-specific sampling plan. Calibration of pH should be performed with at least two buffers which bracket the expected pH range. DO calibrations should be corrected for local barometric pressure readings and altitude.
4. Put on personal protective clothing and equipment as specified in the site-specific health and safety plan.
5. Open the well cover and check condition of the wellhead, including the condition of the surveyed reference mark, if any. If no reference mark exists, create a reference mark on the north side of the well riser using a permanent marker or equivalent. Record the location of the reference mark in the field notes.
6. Monitor the air space at the wellhead for VOCs using a PID/OVM or equivalent immediately upon removal of the well plug and as according to health and safety requirements.
7. Determine the depth to static water level in accordance with SOP 1-6, taking precautions to minimize disturbance of the stagnant water column above the screened interval during water level measurement. Well depth should be obtained from review of the well completion logs or from previous work. Insertion of a water level measuring device to the bottom of the well casing will result in resuspension of settled solids from the formation surrounding the screened interval, thus requiring longer purging times for turbidity and other field parameter equilibration.
8. Dedicated sampling devices (those permanently installed in the well) capable of pumping and sampling are preferred over any other type of device. Any portable sampling device should be slowly and carefully lowered to the middle of the screened interval or slightly above the middle to minimize excessive mixing of the stagnant water in the casing above the screen with the screened interval zone water, and to minimize resuspension of solids collected at the bottom of the well or in the surrounding formation within the screened interval.
9. New polyethylene tubing shall be used for each sample when using non-dedicated sampling equipment. Prepare the pump and tubing for insertion into the well. Lower the pump intake down into the well casing. Connect the flow-through cell in-line with the pump effluent tubing.

**Low- Stress (Low-Flow) Groundwater Sampling**

SOP 1-12

Revision: 2

Date: February 2015

10. Generally, the pump intake should be placed in the mid-point of the screened interval. This provides consistency between sampling rounds. However, if the geology of the screened interval consists of heterogeneous materials with layers of contrasting hydraulic conductivity, the pump intake should be positioned adjacent to the zone of highest hydraulic conductivity (as determined via review of the existing site hydrogeologic conditions/well completion logs). Also, the sampling plan should be consulted to determine if particular zones (e.g., known zones of contamination) are targeted for sampling per DQOs).
11. To achieve low-flow purging conditions, the purge rate should generally not exceed 0.5 L/min. Adjust the pump control to stabilize the flow rate, and therefore minimize drawdown (less than 0.3 foot during purging activities). The water level in the well should be measured throughout the purging process to monitor drawdown. Flow rate can be measured from the discharge tube using a volumetric measuring device (e.g., a graduated cylinder) and a stop watch (Note: determine flow rate by measuring volume in 0.5-minute or 1-minute increments.)
12. Record water level measurements, and field parameters including pH, temperature, specific conductivity, oxidation reduction potential (ORP), DO, turbidity, and flow rate every three to five minutes during the purging process. Record all measurements and observations in the log book or on a Groundwater Purging and Sampling Form (Attachment 1). Purging shall continue until the field parameters have stabilized. Parameters are considered stable when three consecutive readings are within the limits of the criteria defined in Table 5.1 and/or in accordance with the site-specific sampling plan. Turbidity ideally should stabilize below 10 NTU prior to sample collection, particularly if groundwater samples are to be collected for metals or PCB analyses.

**TABLE 5.1 Stabilization of Water Quality Indicator Parameters**

| Parameter             | Units       | Stabilization Criteria   |
|-----------------------|-------------|--|
| Water Level           | Feet/meters | < 0.3 foot (< 0.1 meter)   |
| Temperature           | °F/°C       | ± 3 percent, or ±1.8 degrees Fahrenheit (°F) /±1 degree Celsius (°C)   |
| pH                    | (n/a)       | ± 10 percent, or ±0.1 standards units (SU)   |
| Specific Conductivity | µm/cm       | ±3 percent (microsiemens per centimeter, or µm/cm)   |
| ORP                   | mV          | ±10 millivolts (mV)  |
| Dissolved Oxygen      | mg/L        | ±10 percent, or 0.2 milligram per liter (mg/L) - whichever is greater  |
| Turbidity             | NTU         | ± 1 Nephelometric Turbidity Unit (NTU)<br>(±10 percent for turbidity if greater than 10 NTU)   |
| Flow Rate             | L/min       | 0.1 to 0.5 Liters per minute (L/min) (< 1 L/min), Specific flow rates and sampling rates to be identified in the sampling plan if project/contract required. |

13. In low recharge aquifers, the following steps shall be followed:
- (1) If the initial water level is less than 10 feet above the top of the well screen, then purge the well until dry and allow sufficient recharge to collect samples.
  - (2) If the initial water level in the well is greater than 10 feet above the top of the screen, then care shall be taken to prevent the dewatering of the screened interval during purging of the well.
    - (2a) Continue purging until the water level is between 1 foot (0.3 meter) and 5 feet (1.5 meters) above the top of the screened interval.
    - (2b) Allow the well to recharge, then continue purging until at least one full initial well volume has been purged.
  - (3) Record all data, measurements, and observations in the log book.
14. After field parameters have stabilized, disconnect the flow through cell, and collect groundwater samples directly from the discharge tubing into an appropriate sample container. If using a peristaltic pump to collect VOC samples, refer to item 16 of this SOP for the correct procedure for sampling VOCs with a peristaltic pump. If an in-line, flow-through cell is used to continuously monitor indicator parameters, it should be disconnected or bypassed during sample collection. During sample collection, maintain the pump rate at the same rate used during purging (unless specified in the sampling plan). The pump rate used during sample collection may need to be lowered to minimize aeration, bubble formation, or turbulent flow of water into sample bottles, or to prevent sample preservatives from being washed out of the sample container.

**Low- Stress (Low-Flow) Groundwater Sampling**

SOP 1-12

Revision: 2

Date: February 2015

15. Groundwater sampling (including the collection of all required quality assurance/quality control samples specified in the sampling plan) shall be performed immediately upon completion of purging (unless time for recharge is required for low-recharge wells) using the same equipment used for purging. Sampling should occur in a progression from the least to the most contaminated well, if this is known. Generally, volatile (e.g., solvents and fuel constituents) and gas sensitive (e.g., Fe<sup>2+</sup>, CH<sub>4</sub>, H<sub>2</sub>S/HS<sup>-</sup>, and alkalinity) analytes should be sampled first. The sequence in which samples for most inorganic parameters are collected is immaterial unless filtered (dissolved) samples are required. Filtered samples should be collected last and in-line filters should be used. After all unfiltered samples have been collected, a 0.45 micron (µm) in-line filter shall be inserted in the discharge line for collection of filtered samples, as required.
16. VOC samples should not be collected directly from the discharge end of a peristaltic pump. After field parameters have stabilized, and all other samples have been collected as required, stop the pump and simultaneously pinch the discharge end of the tubing shut. Disconnect the flow-through cell. Remove the tubing from the well and fill the VOC sample containers from the influent end of the sample tubing, (the end of the tubing that was located down-well during purging activities). The flow rate when filling sample vials may be controlled by setting the peristaltic pump in reverse.
17. Place all samples in a cooler with ice or ice packs to comply with project, laboratory, and/or regulatory requirements.
18. After sampling activities have been completed, remove the portable pump assembly from the well, if used, and decontaminate all non-disposable components. Replace the well plug. Secure the well plug and well cover. Clean up the work area: containerize and/or dispose of purge water as required by the site-specific sampling plan, and dispose of tubing and all other disposable sampling equipment as investigation derived waste (IDW) after each use as described in the site-specific sampling plan.

**6.0 Restrictions/Limitations**

Only grounded electrical devices should be used for low-flow sampling activities. If a gasoline-powered electrical source is used, place portable power sources (e.g., generators) 50 feet (15 meters) or farther from the wellhead to prevent potential contamination of samples. Additionally, it should be clearly noted in the field notes or on the Groundwater Sampling Log (Attachment 1) if a well has been pumped dry and allowed to recharge prior to sample collection, as low-flow sampling data is no longer applicable.

**7.0 References**

ASTM D6452-99(2012)e1, Standard Guide for Purging Methods for Wells Used for Groundwater Quality Investigations, ASTM International, West Conshohocken, PA, 2012.

ASTM D4448-01(2013), Standard Guide for Sampling Ground-Water Monitoring Wells, ASTM International, West Conshohocken, PA, 2013.

Puls, R.W. and M.J. Barcelona. April 1996. *Low-Flow (Minimal Drawdown) Ground Water Sampling Procedures*. U.S. EPA, Ground Water Issue, Publication Number EPA/540/S-95/504.

U. S. Environmental Protection Agency. May 2002. *Groundwater Sampling Guidelines for Superfund and RCRA Project Managers*. Ground Water Forum Issue Paper, EPA 542-S-02-001, OSWER, Technology Innovative Office, Washington, D.C.



**Drum Sampling**

SOP 1-13

Revision: 2

Date: February 2015

Approved:

  
Signature

Technical Review:

Dave Sembrot/Shawn Oliveria

**1.0 Objective**

The purpose of this technical standard operating procedure (SOP) is to define requirements for drum sampling at hazardous waste sites for disposal, bulking, recycling, segregation, and classification purposes.

**2.0 Background****2.1 Definitions**

**Drum**- A portable container, in which material is stored, transported, treated, disposed, or otherwise handled. The most frequent type of containers sampled by field investigators for chemical analysis and/or physical testing are 55 gallon drums.

**Hazardous waste** – Before a material can be classified as a hazardous waste, it must first be a *solid waste*. Hazardous wastes are regulated by 40 Code of Federal Regulation (CFR) Parts 260-268. *Solid waste* is any discarded material that is not excluded under §261.4(a) or that is not excluded by a variance granted under CFR §§260.30 and 260.31 or that is not excluded by a non-waste determination under §§260.30 and 260.34

**Photoionization Detector (PID)** - A portable, hand-held instrument that measures the concentration of gaseous organic compounds through the photoionization of organic vapors.

**4 Gas Multi-Gas Detector** – Real time gas detection systems capable of measuring for LEL, H<sub>2</sub>S, and %O<sub>2</sub>.

**Bung wrench** – A common tool for manually opening drums. Bung wrenches are usually constructed of non-sparking metal alloy (e.g. brass, bronze/manganese, aluminum, etc.) formulated to reduce the likelihood of sparks.

**Drum deheader** - A tool for manually opening a drum if a bung is not removable with a bung wrench. Drum deheaders are constructed of forged steel with an alloy steel blade and designed to cut off the lid of a drum by means of a scissor-like cutting action. This tool can only be used for closed head drums.

**Backhoe spike** – Tool used to open drums remotely for sampling. A backhoe spike is made of non-sparking metal that is attached or welded to a backhoe bucket. It is used mostly used in large-scale operations.

**Pneumatic devices** – A pneumatic bung remover consists of a compressed air supply that is controlled by a two-stage regulator. This device has a high pressure air line of desired length which delivers compressed air to a pneumatic drill, which is adapted to turn the bung fitting selected to fit the bung to be removed. The pneumatic drill has an adjustable bracketing system that allows the drill to be positioned and aligned over the drum. The adjustable bracketing system must be removed prior to sampling the drum. These tools require the drum to be upright and relatively level. Bungs that are rusted shut cannot be removed with this device.

**Hydraulic Drum Opener** – Tool used to open drums remotely for sampling by hydraulic pressure.

**Glass drum thief sampler** – Cost effective, quick and disposable tool used to sample drums. Glass drum thieves are typically 6mm to 16mm inner diameter (I.D) and 48 inches long.

**COLIWASA sampler** - A composite liquid waste sampler (COLIWASA) is used to collect a multiphase waste sample from the full depth of a drum and maintains the sample in a transfer tube until delivery to the sample bottle. COLIWASA samplers usually consist of a 152 cm by 4 cm I.D. section of tubing with a neoprene stopper at one end attached by a rod running the length of the tube to a locking mechanism at the other end.

**Drum Sampling**

SOP 1-13

Revision: 2

Date: February 2015

**Core device** – Tool used to sample drum solids. This sampler consists of a series of extensions, a T-handle, and the coring device.

**2.2 Associated Procedures**

- SOP 1-2, *Sample Custody*
- SOP 1-10, *Field Measurement of Organic Vapors*
- SOP 2-1, *Packaging and Shipping Environmental Samples*
- SOP 4-1, *Field Logbook Content and Control*
- SOP 4-2, *Photographic Documentation of Field Activities*
- SOP 4-5, *Field Equipment Decontamination at Nonradioactive Sites*

**2.3 Discussion**

Drum sampling is necessary to characterize or categorize the contents of drums to obtain a quick, preliminary assessment of the types and layers of materials contained in them. The data can be used to make decisions regarding potential chemicals or contaminants present and the types of waste or material hazard characteristics of each drum. This information is then utilized to determine drum staging or restaging, bulking, transferring or compositing of the drum contents.

The Site manager shall ensure that appropriate H&S planning is performed prior to executing any planned activity of this type. That planning shall include a thorough hazard analysis along with atmospheric monitoring, personnel training, PPE, and emergency response requirements.

Prior to performing activities of this type, CDM Smith employees shall ensure that they have read and understood the applicable H&S planning and procedures related to the planned activity..

**3.0 General Responsibilities**

**Site Manager** - The site manager is responsible for ensuring that field personnel are trained in the use of this and related SOPs and the required equipment. The site manager is responsible for ensuring that all necessary health, safety, and security hazards are identified and addressed.

**Field Team Leader** - The field team leader (FTL) is responsible for ensuring that sampling efforts are conducted in accordance with this procedure and any other SOPs pertaining to specific media sampling. The FTL must also ensure that the quantity and location of drum samples collected meet the requirements of the site-specific plans. The FTL must ensure that all drum sampling logs are properly and completely filled out at the time of sampling. Each sampling log should detail the number, thickness and type of physical layers present in the drums and that all drum sampling log labels clearly identify and describe which samples belong to which layers of each drum sampled.

**Note:** Responsibilities may vary from site to site. Therefore, all field team member responsibilities shall be defined in the field plan or site/quality assurance project plan (QAPP).

**4.0 Required Equipment**

All or part of the equipment listed under the “as needed” category may be required at any specific site, depending on the plan(s) for that site.

- |  |                                 |
|--|---------------------------------|
| ▪ Site-specific plans  | ▪ Chain of custody records      |
| ▪ Field logbook  | ▪ Drum overpacks                |
| ▪ Site related MSDSs (if available)                              | ▪ Chemical reference guides     |
| ▪ Indelible black ink pens and markers                           | ▪ Kimwipe or paper towels       |
| ▪ Labels and appropriate forms/documentation for sample shipment | ▪ Clean plastic sheeting        |
|  | ▪ Absorbent material for spills |

**Drum Sampling**

SOP 1-13

Revision: 2

Date: February 2015

- Appropriate sample containers (e.g. wide mouth amber glass jars with Teflon cap liner, approximately 500 mL volume)
- Insulated cooler and waterproof sealing tape
- Ice bags or “blue ice”
- Any personal protective equipment specified in the site-specific health and safety plan
- Drum opening devices
- Appropriate decontamination equipment and supplies
- Plastic zip-top bags
- Tap and deionized water
- Water spray bottle
- Appropriate photographic equipment and supplies
- Clear waterproof tape

As needed:

- Global Positioning System (GPS) unit
- Spare parts for all equipment
- Tape measure

**5.0 Procedures****5.1 Preparation**

The following steps shall be taken when preparing for sampling drums:

1. Review site-specific health and safety plan and project plans before initiating sampling activity. Air monitoring requirements, and action levels should be identified and implemented. Appropriate PPE and various training requirements such as HAZWOPER and/or respiratory protection shall be in place
2. Determine the extent of the sampling effort, sampling methods to be employed, and the types and amounts of equipment and supplies needed.
3. Assess potential or likely materials contained in the drums to be sampled (i.e. visible labels, container material, construction, size and type). Assess the physical state of the drums and its current staged position to determine if any hazards may exist and what safety precautions need to be taken prior to approaching the drums.
4. Don the appropriate personal protective clothing as dictated by the site-specific health and safety plan. Decontaminate or preclean equipment, and ensure it is in working order.
5. Identify and mark all drums to be restaged in preparation for sampling and which drums will be sampled in place.

**5.2 Drum Excavation (if required)**

**Note:** If it is presumed that buried drums are on-site, then geophysical investigation techniques should be used to approximate the location and depth of the drums prior to excavation or digging activities.

1. Drum identification and inventory should be conducted during excavation and recorded in the sampling logbook (e.g. location, date of removal, drum ID number, overpack status, etc.) Any information regarding buried drums should also be taken into consideration prior to excavation.
2. Excavation of drums must be accomplished by a qualified conventional heavy equipment operator.
3. Excavate soil around the drum with non-sparking hand tools.
4. Perform a visual inspection to determine the condition of the drums.

**Warning:** Ensure that all excavation areas have been cleared of underground or overhead utility lines.

**5.3 Drum Inspection and Staging**

**Drum Sampling**

SOP 1-13

Revision: 2

Date: February 2015

**Note:** All personnel should assume that unmarked drums contain hazardous materials until their contents have been identified.

1. Drums should be inspected for the following:
  - a. Drum condition: pressurization (bulging/dimples) corrosion, rust, punctures, bungs, crystallization round the drum opening, holes, stains, and leaking contents
  - b. Symbols, words, or other markings on the drum indicating hazards (e.g. explosive, radioactive, toxic, flammable)
  - c. Signs that the drum is under pressure
  - d. Shock sensitivity
2. Ambient air monitoring should be done to determine presence of unsafe levels of volatile organics, explosives, or radioactive materials, such as with a photoionization detector (PID), 4 gas multi-meter, and radioactivity detection monitor as specified in the site-specific health and safety plan. Depending on site conditions, cyanide fumes, pH, and halogen vapors should also be screened.
3. If necessary, classify the drum(s) into categories such as: radioactive, leaking/deteriorating, bulging, lab packs, explosive/shock sensitive, and empty.
4. Use color coded tags, labels, or bands to identify the drum's category based on visual inspection.
5. Record the identification and description of each drum in the field logbook (e.g. condition, unusual markings, burial or storage location, and field monitoring information).
6. Stage drums in an isolated area due to potentially suspect radioactive, explosive, or shock-sensitive materials.
7. Physically separate drums by the following categories: containing liquids, solids, containing lab packs, and empty.
8. A qualified forklift operator should move the drums by a forklift equipped with drum grabbers or a barrel grapple to an approved staging area.

**Note:** Refer to state and federal regulations for specific inspection and staging area requirements.

**5.4 Drum Opening**

**Note:** The drum opening area should be physically separated from the drum removal and drum staging operations. (Only non-sparking tools should be used.)

**5.4.1 Manual Drum Opening with a Bung Wrench (Appendix A – Figure 1)**

1. Position drums upright with the bung up, or, for drums with bungs on the side, laid on their sides with the bung plugs up.
2. The wrenching motion should be a slow, steady pull across the drum. If the length of the bung wrench handle provides inadequate leverage for unscrewing the plug, a "cheater bar" can be attached to the handle to improve leverage.

**5.4.2 Manual Drum Opening with a Drum Deheader (Appendix A – Figure 2)**

1. Position the cutting edge just inside the top chime and tighten the adjustment screw so that the deheader is held against the side of the drum.
2. Move the handle of the deheader up and down while sliding the deheader along the chime to enable the entire top to be cut off.
3. Make the initial cut very slowly to allow for gradual release of any built-up pressure.

**Drum Sampling**

SOP 1-13

Revision: 2

Date: February 2015

4. Decontaminate the deheader after each drum use to avoid cross contamination and/or adverse chemical reactions from incompatible materials.

**5.4.3 Remote Drum Opening with a Backhoe Spike/Beryllium Punch (Appendix A – Figure 3)**

1. Place drums in rows with adequate aisle space to allow ease in backhoe maneuvering.
2. After the drum has been staged, punch a hole in the drum head or lid with the spike.
3. Decontaminate the spike after each drum is opened to prevent cross contamination and/or adverse chemical reactions from incompatible materials.

**Note:** Remotely operated drum opening tools are the safest available means of drum opening compared to manual methods of opening.

**5.4.4 Remote Drum Opening with Hydraulic Devices (Appendix A – Figure 4)**

1. Push the piercing device (non-sparking, metal point attached to a hydraulic line) using hydraulic pressure.
2. Attach the piercing device so that a hole for sampling can be made in either the side or head of the drum.
3. Use the piercer to establish a tight seal after penetrating the drum.

**Note:** Some metal piercers are hollow or tube-like, and therefore, can be left in place to serve as a permanent tap or sampling port.

**5.4.5 Remote Drum Opening with Pneumatic Devices (Appendix A – Figure 5)**

1. Set the container upright and relatively level.
2. Select a bung fitting to fit the bung to be removed.
3. Attach the adjusting bracketing system to the drum and align the pneumatic drill over the bung. This must be done prior to operating the drill.
4. Operator must step away from the drum to operate the equipment.
5. Once the bung has been loosened, remove the bracketing system prior to sampling the drum.

**Note:** This device cannot be used to remove rusted bungs. This device also does not permit the slow venting of the drum, therefore, appropriate precautions are necessary.

**5.5 Liquid Drum Sampling**

**Note:** Samples collected from drums are considered waste samples and as such, adding preservatives is not required due to the potential reaction of the sample with the preservative. Samples should, however, be cooled to 4°C and protected from sunlight in order to minimize any potential reaction due to the light sensitivity of the sample.

After the drum has been opened, preliminary monitoring of headspace gases should be performed with a PID or 4 gas multi-meter. Also, radioactivity readings should be monitored using an approved detection device. The following techniques should be used in order to take a sample that represents the entire depth of the drum, to check the presence of sludge at the bottom of the drum, and to sample solids:

**5.5.1 Glass Drum Thief Sampler (Appendix A – Figure 6)**

1. Remove the cover from the sample container.

**Drum Sampling**

SOP 1-13

Revision: 2

Date: February 2015

2. Insert glass tubing almost to the bottom of the drum or until the solid layer is encountered. **Note:** About one foot of tubing should extend above the drum. Lift the clear glass sampler to inspect the liquid for any signs of layering which may indicate a non-aqueous phase either floating or sinking within an aqueous layer. Be aware of any solid or semi-solid layers within the drum.
3. Allow the waste in the drum to reach its natural level in the tube.
4. Cap the top of the sampling tube with a tapered stopper or thumb, ensuring liquid does not come into contact with stopper.
5. Carefully remove the capped tube from the drum and insert the uncapped end into the appropriate sample container.
6. Release the stopper and allow the glass thief to drain until the container is approximately two-thirds full.
7. Remove tube from the sample container, break it into pieces and place the pieces in the drum.
8. Cap the sample container tightly and label it. Place the sample container into a cooler with ice.
9. Replace the bung or clean plastic sheeting over the drum.
10. Record all samples in the field logbook. Ensure every layer present in the drum is represented in separate sampling containers and that the thickness of each layer is noted so that volumes present in the drum can be estimated.
11. Relocate the samples into the decontamination area and package them in accordance with approved field plans.
12. Complete the chain of custody.

**5.5.2 COLIWASA Sampler (Appendix A – Figure 7)**

1. Open the sampler by placing a stopper rod handle in the T-position and pushing the rod down until the handle sits against the sampler's locking block.
2. Slowly lower the sampler into the liquid waste. Lower the sampler at a rate that permits the levels of the liquid inside and outside the sampler tube to be about the same.

**Note:** If the level of the liquid in the sample tube is lower than that outside the sampler, the sampling rate is too fast and will result in non-representative sample.

3. When the sampler stopper hits the bottom of the waste container, push the sampler tube downward against the stopper to close the sampler. Lock the sampler in the closed position by turning the T-handle until it is upright and one end rests tightly on the locking block.
4. Slowly withdraw the sampler from the waste container with one hand while wiping the sampler tube with a disposable cloth with the other hand. Inspect the liquid in the COLIWASA for any signs of layering which may indicate a non-aqueous phase either floating or sinking within an aqueous layer. Be aware of any solid or semi-solid layers within the drum.
5. Carefully discharge the sample into the appropriate sample container by slowly pulling the lower end of the T-handle away from the locking block while the lower end of the sampler is positioned in the sample container.
6. Cap the sample container tightly and label it. Place the sample into a container and place it into a cooler with ice.
7. Replace the bung or place clean plastic sheeting over the drum.

**Drum Sampling**

SOP 1-13

Revision: 2

Date: February 2015

8. Record all samples in the field logbook. Ensure every layer present in the drum is represented in separate sampling containers and that the thickness of each layer is noted so that volumes present in the drum can be estimated.
9. Relocate the samples into the decontamination area and package them in accordance with approved field plans.
10. Complete the chain of custody.

**5.6 Soil or Solid Drum Sampling****5.6.1 Coring Device**

**Note:** When sampling drum solids, a composite sample should be taken from different areas within the drum.

1. Assemble the sampling equipment.
2. Remove the cover from the sample container.
3. Insert the sampling device to the bottom of the drum. The extensions and the "T" handle should extend above the drum.
4. Rotate the coring device to cut a core of material.
5. Slowly withdraw the sampling device so that as much sample material as possible is retained within it.
6. Transfer the sample to the appropriate sample container, and label it.

**Note:** A stainless steel spoon or scoop may be used.

7. Replace the bung or place clean plastic sheeting over the drum.
8. Record all sample in the field logbook.
9. Relocate the samples into the decontamination area and package them in accordance with approved field plans.
10. Complete the chain of custody.

**6.0 Restrictions/Limitations**

Drum sampling is one of the most hazardous site activities. The use of remote drum opening and sampling equipment whenever feasible is highly recommended in regards to health and safety.

Glass drum thief samplers are cost effective and efficient tools for quickly obtaining representative samples within drums containing liquid materials. When solids or semi-solids are encountered the glass drum thief sampler may shatter causing a the potential for hand injuries. Caution must be exercised when utilizing these samplers within drums with multi-phase layers in drums. Consideration for alternative or multiple sampling devices must be given to sample planning to account for liquid, semi-solid and solid layers may be present in drums.

Air monitoring action levels must be defined and understood prior to conducting any site activity

When using the COLIWASA sampler, major drawbacks make it an impractical disposable item such as difficulty in field decontamination in the field and relatively high costs in relation to alternative procedures. It still has applications, however, especially in instances where a true representation of a multiphase waste is absolutely necessary.

**7.0 References**

**Drum Sampling**

SOP 1-13  
Revision: 2  
Date: February 2015

40 Code of Federal Regulations Parts 260-268.

ASTM D5680-14 – Standard Practice for Sampling Unconsolidated Solids in Drums or Similar Containers

ASTM D6063-11 – [Guide for Sampling of Drums and Similar Containers by Field Personnel](#)

U.S. Environmental Protection Agency. November 1994. *Drum Sampling*. SOP#: 2009.

U.S. Environmental Protection Agency. January 1986. *Drum Handling Practices at Hazardous Waste Sites*, EPA-600/2-86-013.

U.S. Environmental Protection Agency, Region IV. November 2007. Science and Ecosystem Support Division Operating Procedure. *Waste Sampling*, SESDPROC-302-R1.

Martin Marietta Energy Systems, Inc. 1998. *Environmental Surveillance Procedures Quality Control Program*, ESH/Sub/87-21706/1.

Hackman et al. 2001. *Hazardous Waste Operations and Emergency Response Manual and Desk Reference*.



Appendix A

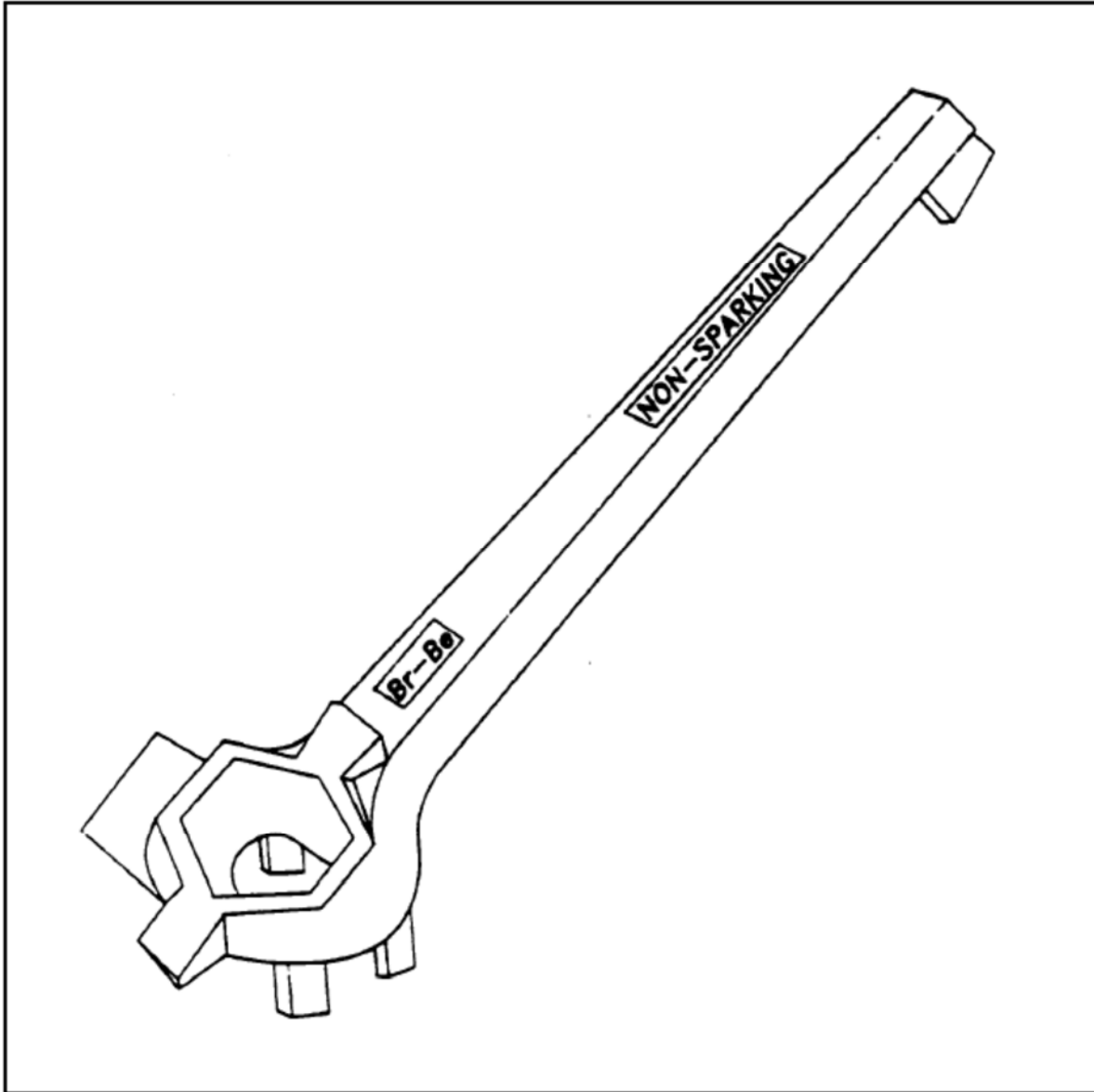

Figure 1. Universal Bung Wrench

Appendix A

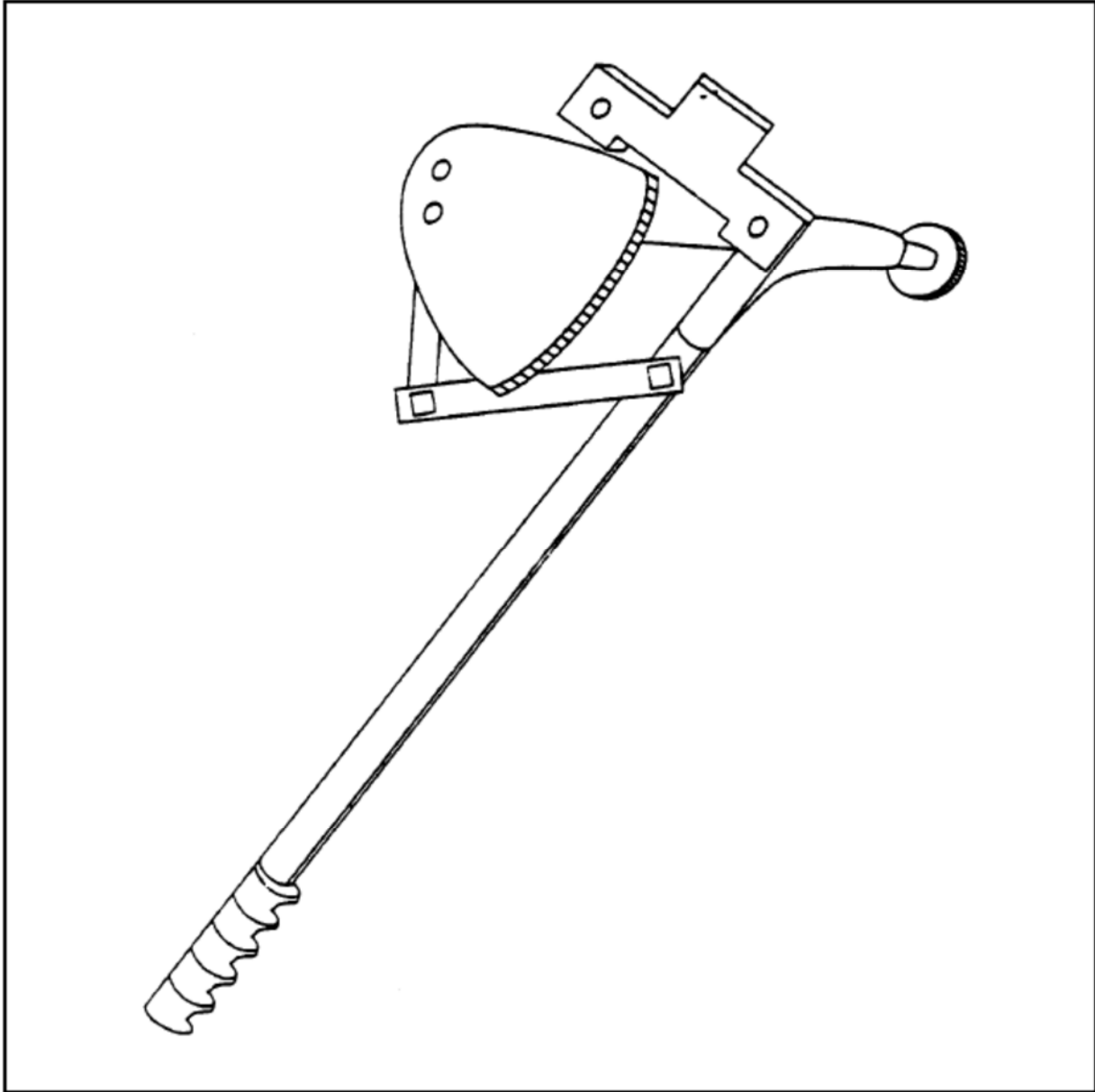

Figure 2. Drum Deheader

Appendix A

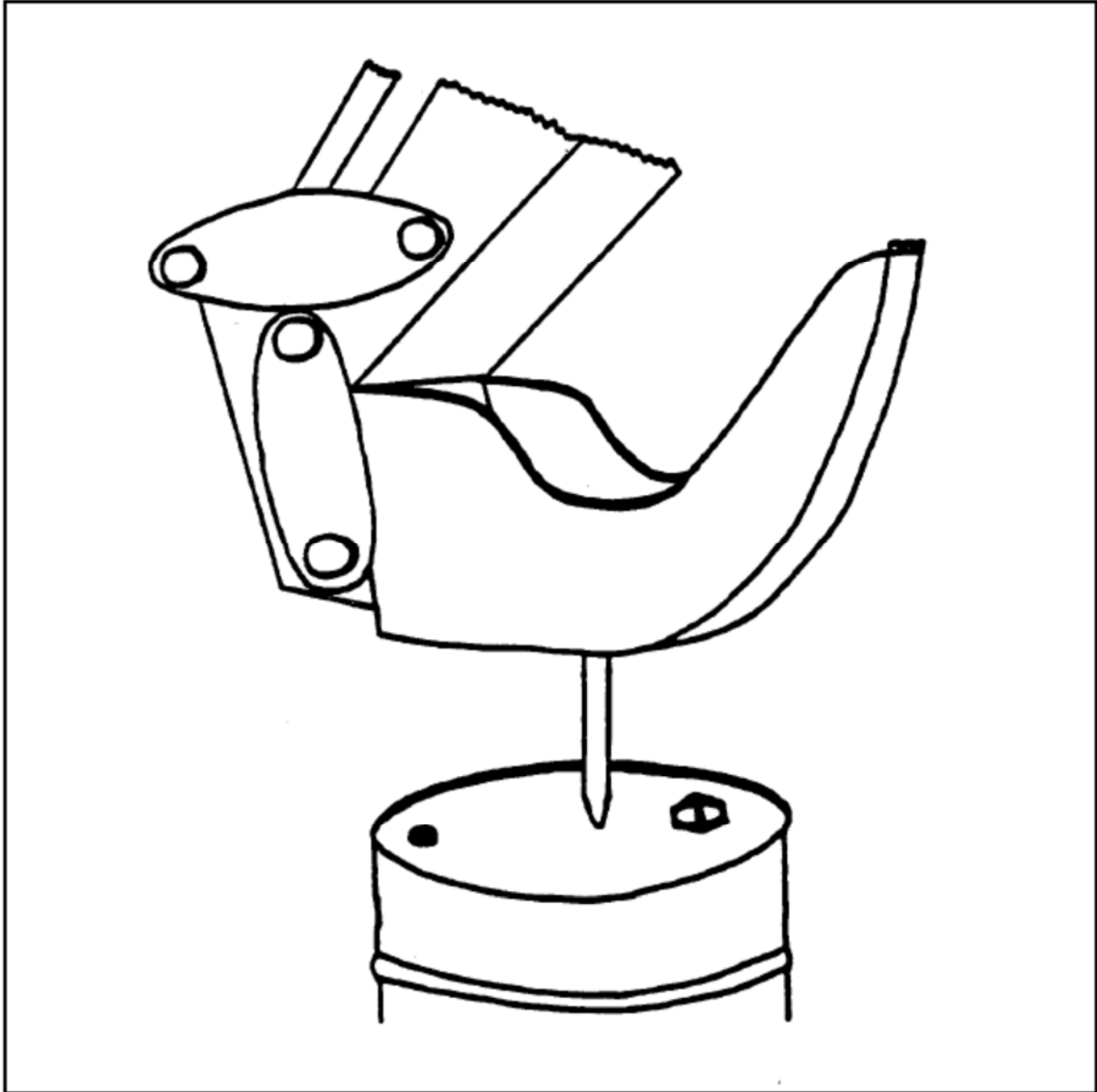

Figure 3. Backhoe Spike

Appendix A

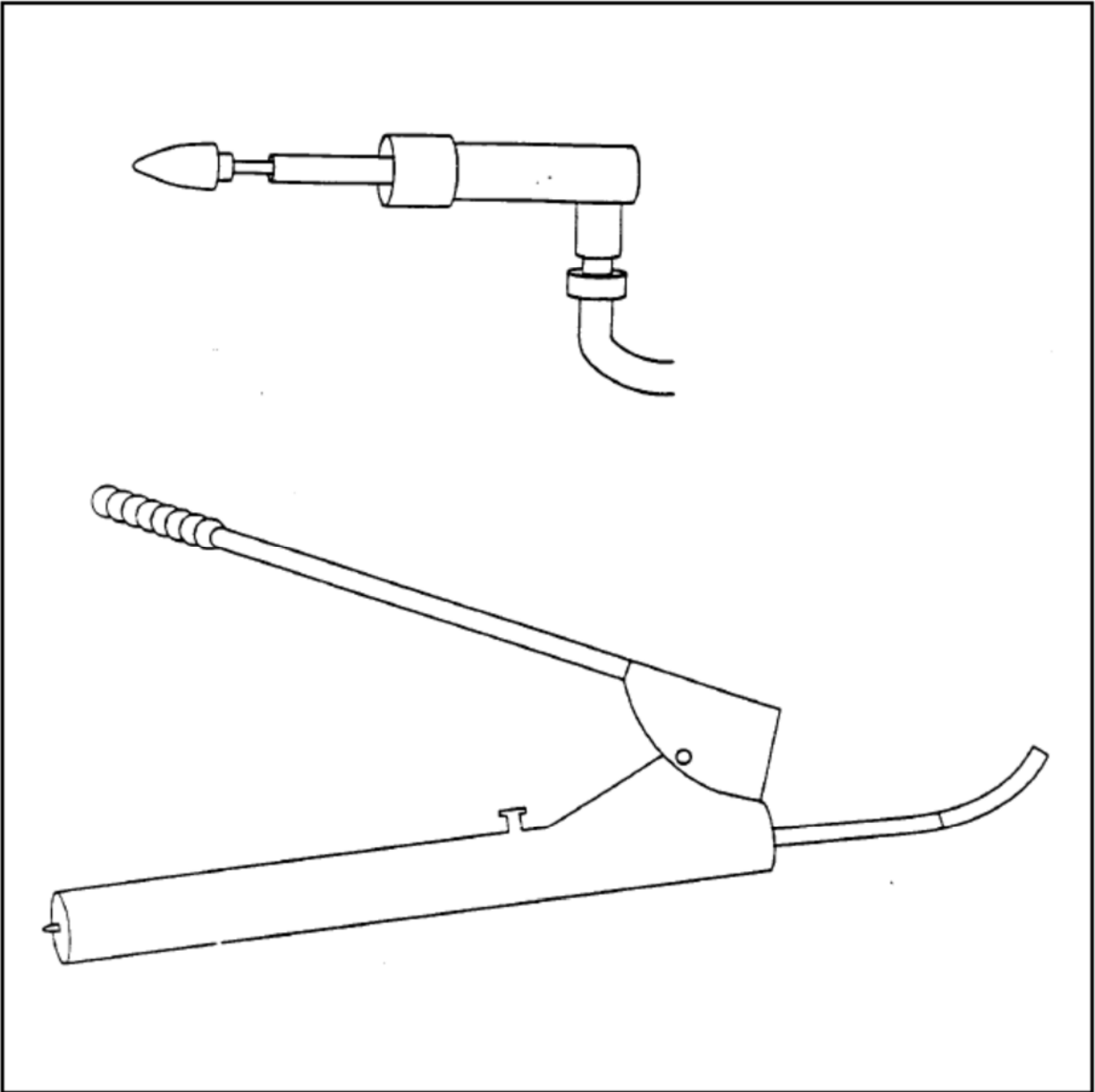

Figure 4. Hydraulic Drum Opener

Appendix A

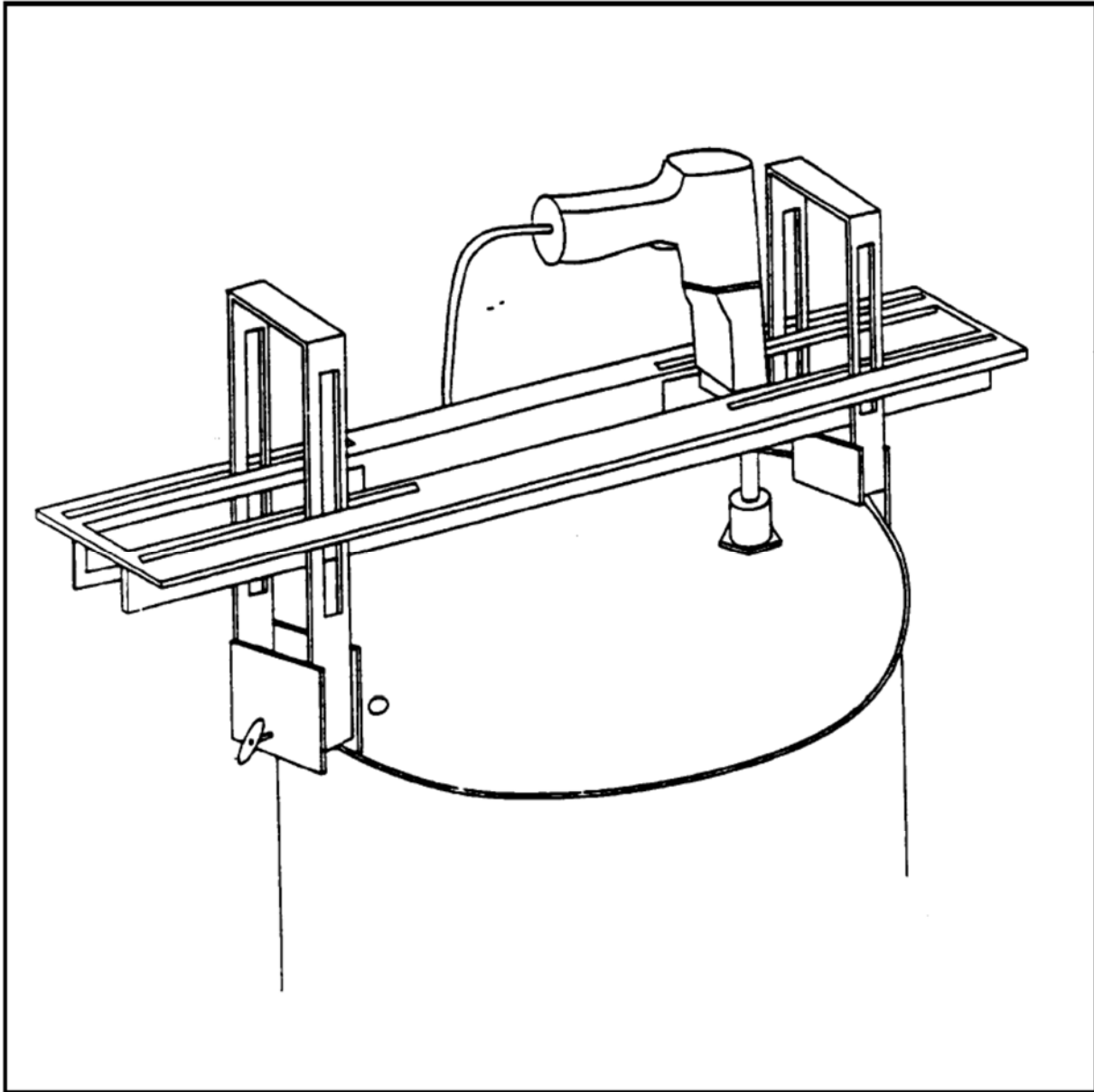

Figure 5. Pneumatic Bung Remover

Appendix A

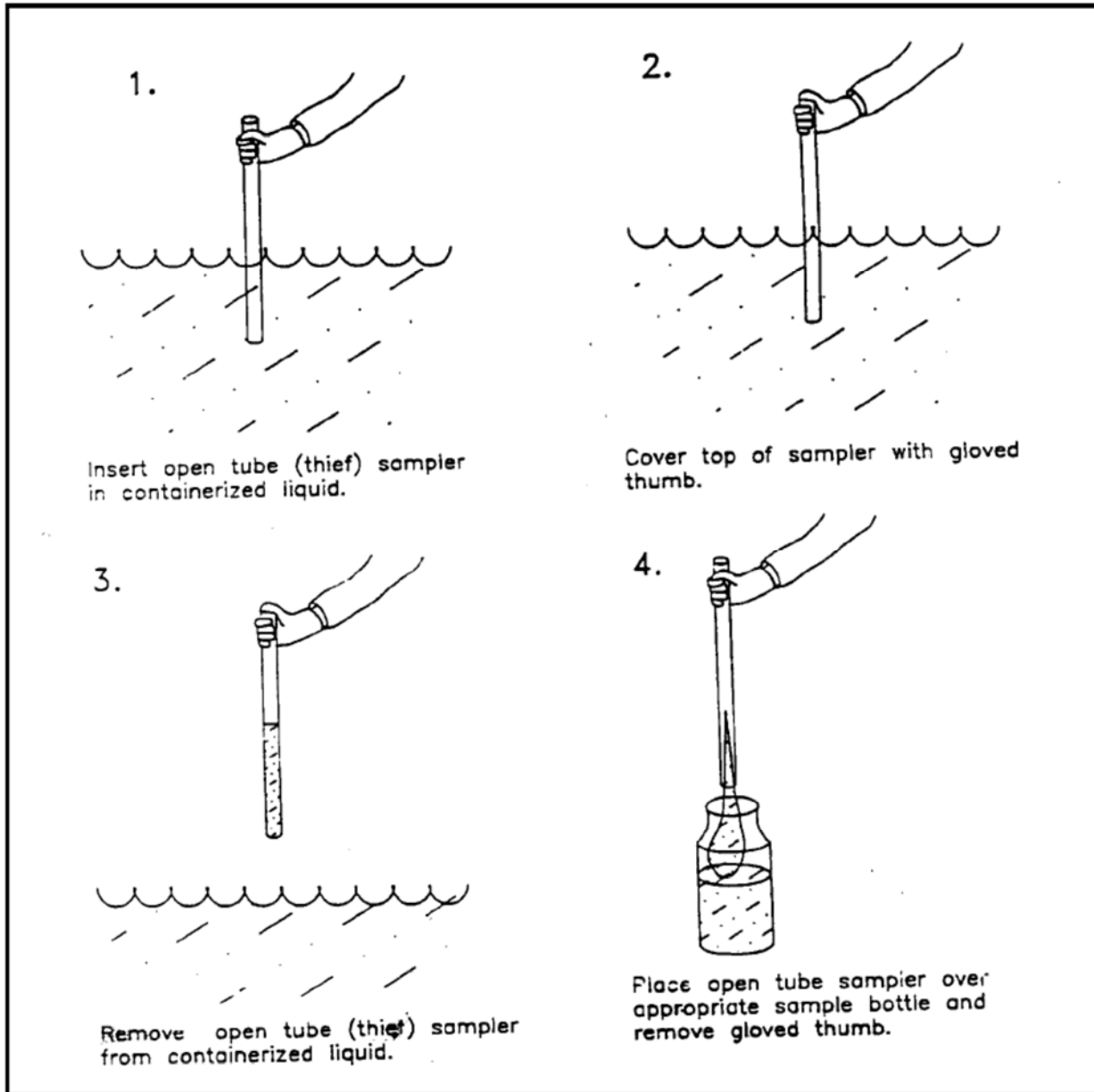

Figure 6. Glass Thief

Appendix A

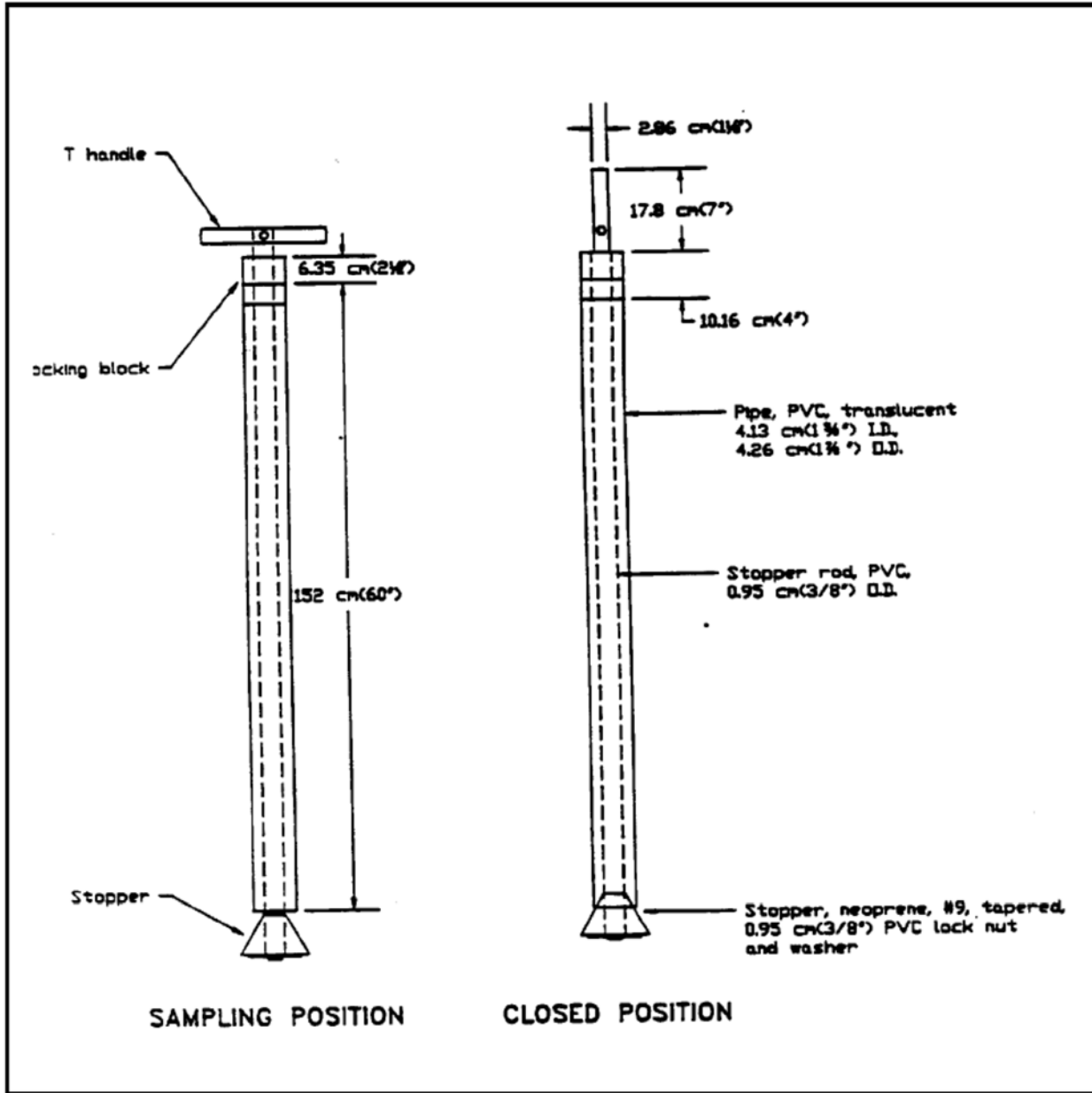

Figure 7. COLIWASA





**Lagoon Sampling**

SOP 1-14

Revision: 2

Date: February 2015

Approved:

  
 Signature

Technical Review:

Murray Wade

**1.0 Objective**

The purpose of this technical standard operating procedure (SOP) is to define requirements for collection of surface water samples and containment of sediment/sludge samples in lagoons. This procedure is also applicable for sampling rivers, lakes, ponds, streams, embayments, mudflats, and surface impoundments.

**2.0 Background****2.1 Definitions**

**Surface Water** - Water that flows over or rests on the land and is open to the atmosphere. This includes lagoons, ditches, streams, rivers, lakes, pools, ponds, and basins.

**Shallow Surface Water** - Water within 1 to 2 feet of the surface of a body of water.

**Deep Surface Water** - Water deeper than 2 feet of the surface of a body of water.

**Grab Sample** - A discrete portion or aliquot taken from a specific location at a given point in time.

**Simple Composite** - Two or more subsamples taken from a specific media and site at a specific point in time. The subsamples are collected and mixed. Then a single average sample is taken from the mixture.

**Temporal Composite** - Two or more subsamples taken from a specific media and site over a period of time. The subsamples are collected and mixed. Then a single average sample is taken from the mixture.

**Churn Splitter** - Large vessel for compositing subsamples. Includes a mechanism to agitate the water to keep solids suspended.

**Sediment** - Geologic and/or organic material underlying a body of water. The material has been transported by a fluid and deposited within the boundaries of the body of water.

**Sludge** - Materials ranging in type from dewatered solids to high viscosity liquids. The material may exist suspended throughout the water or settled from the water as all or part of the sediment.

**2.2 Associated Procedures**

- SOP 1-2, *Sample Custody*
- SOP 2-1, *Packaging and Shipping Environmental Samples*
- SOP 4-1, *Field Logbook Content and Control*
- SOP 4-2, *Photographic Documentation of Field Activities*
- SOP 4-5, *Field Equipment Decontamination at Nonradioactive Sites*

**2.3 Discussion**

Surface water and sediment/sludge samples are collected to determine the type(s) and level(s) of contamination in a particular surface water body such as a lagoon and/or its biological disposition. Sediment/sludge samples will provide a more historical account of contamination than will water samples because of the nature of the matrix.

**3.0 General Responsibilities**

**Site Manager** - The site manager is responsible for ensuring that field personnel are trained in the use of this and related SOPs and the required equipment.

**Lagoon Sampling**

SOP 1-14

Revision: 2

Date: February 2015

**Field Team Leader** - The field team leader (FTL) is responsible for ensuring that sampling efforts are conducted in accordance with this procedure and any other SOPs pertaining to specific media sampling. The FTL must also ensure that the quantity and location of sediment/sludge samples collected meet the requirements of the site-specific plans.

**Note:** Responsibilities may vary from site to site. Therefore, all field team member responsibilities shall be defined in the field plan or site/quality assurance project plan (QAPP).

**4.0 Required Equipment**

All or part of the equipment listed under the “as needed” category may be required at any specific site, depending on the plan(s) for that site.

- Site-specific plans
- Field logbook
- Indelible black ink pens and markers
- Labels and appropriate forms/documentation for sample shipment
- Appropriate sample containers
- Insulated cooler and waterproof sealing tape
- Ice bags or “blue ice”
- Plastic zip-top bags
- Clear waterproof tape
- Personal protective clothing and equipment
- Latex or appropriate gloves
- Rubber boots and/or rubberized waders
- Life jacket
- Teflon or stainless steel mixing bowls or trays
- Aluminum foil
- Kimwipe or paper towels
- ½- to ¾-inch (12- to 19-mm) braided nylon line or Teflon-coated wire rope
- Clean plastic sheeting
- Tap and deionized water
- Water spray bottle
- Appropriate photographic equipment and supplies
- Appropriate decontamination equipment and supplies
- Eckman grab sampler for depositional area (primarily stream) sediment sampling
- Ponar sampler for lake sampling
- Stainless steel or Teflon® spoons, spatulas, or scoops

As needed:

- Global Positioning System (GPS) unit
- Hand or gravity corer with extensions or stainless steel hand auger
- Core liners of Teflon, stainless steel, brass, aluminum, or polybutyrate, as specified in the site-specific plan(s)
- Stainless steel push tubes
- Dredge with 15- to 20-foot (4.5- to 6.0-meter) sampling pole (hollow) and insert (e.g., Peterson, Eckman, Ponar)
- Pond sampler with 1-liter (L) beaker (preferably Teflon®), clamp, and heavy-duty telescoping pole
- Weighted bottle sampler, 1-L capacity (preferably Teflon) and handle; see USGS Open File Report 2005-1087 for selection of sampler; a Kemmerer or Van Dorn sampler may be used if Teflon is not required
- Motorized coring device
- Boat with depth finder for deep water or inaccessible shorelines
- Any personal protective equipment specified in the site-specific health and safety plan
- Spare parts for all equipment
- Tape measure
- Churn splitter
- Peristaltic pump or suitable replacement
- Temperature, pH, and conductivity meter(s), dissolved oxygen meter, redox potential meter (as required by project plan)

**5.0 Procedures****5.1 Preparation for Sampling Surface Water**

The following steps should be taken when preparing for sampling surface water:

1. Review site-specific health and safety plan and project plans before initiating sampling activity.
2. Don the appropriate personal protective clothing as dictated by the site-specific health and safety plan.

**Lagoon Sampling**

SOP 1-14

Revision: 2

Date: February 2015

3. Select wadeable lagoon sampling locations that exhibit cross-sectional homogeneity and are well-mixed. Avoid areas where the channel is constricted or bends where scouring may have occurred.

**Note:** For lake samples, the investigator should consider the lake stratification caused by seasonal temperature differences. If possible, select a location that can be described precisely, such as xx feet upstream of xx bridge. Use caution when wading in lagoons more than 1 to 2 feet deep. Flowing water can be a safety hazard.

4. Prepare sampling site by laying out clean plastic sheeting on the ground or any flat, level surface near the sampling area. Then place equipment to be used on the plastic sheeting.
5. Make field measurements as required by the project plans in physical, chemical, and biological characteristics of the water (e.g., discharge, gage height, temperature, dissolved oxygen, conductivity, pH).
6. The samples should be collected from areas of least to greatest contamination (when known). When collecting several samples in 1 day, always collect from downstream to upstream.
7. The sampler should be facing upstream when sampling, both for proper sample collection and for safety (i.e. ability to observe floating objects).
8. Document the sampling events, recording all information in the designated field logbook and take photographs if required or if possible. Document any and all deviations from this SOP and include rationale for changes.
9. The collection points should be located on a site map and described in the field logbook. Use GPS to determine location if required or if possible.
10. Label each sample container with the appropriate information. Secure the label by covering it with a piece of waterproof clear tape.
11. Decontaminate reusable sampling equipment after sample collection according to SOP 4-5.
12. Processes for verifying depth of samples must be included in site-specific project plans.
13. Check that a trip blank/temperature blank, when necessary, is included in the chilled cooler. Quality assurance/quality control sample requirements vary from project to project. Consult the project-specific work plan for quality requirements.

**5.2 Shallow Surface Water Sample Collection for Wadeable Lagoons****5.2.1 Method for Collecting Samples for Volatile Organic Compound Analysis**

All volatile organic compound (VOC) samples should be discrete samples. The following steps must be taken when collecting shallow surface water VOC samples:

If the volatile organic analysis (VOA) vials do not require a preservative:

1. Approach the sample location from downstream; do not enter the sample area. Slowly submerge VOA vials completely into an area of gently flowing water and fill. Do not disturb bottom sediments. The open end of the vials should be pointed upstream.

**Note:** When collecting samples for VOC analysis, avoid collecting from a surface water point where water is cascading and aerating.

2. Cap the VOA vial while it is underwater. Be sure to dislodge all air bubbles from the cap before sealing the vial.

**Lagoon Sampling**

SOP 1-14

Revision: 2

Date: February 2015

3. Turn the capped vial upside down and check for air bubbles. Tap the bottom of the vials to dislodge any bubbles that may have formed around the cap or sides. Discard and resample if bubbles are present.
4. Proceed to Step 5 below.

If the VOA vials require a preservative [i.e. hydrochloric acid (HCl)]:

1. Collect a sufficient sample in a clean glass jar as in Steps 1 and 2 above for unpreserved vials. Specific sampling devices to be used must be specified in site-specific plans.
2. Decant the sample immediately into pre-preserved VOA vials. It is recommended that the amount of preservative be predetermined on a separate aliquot of sample that is subsequently discarded. Tip vials slightly while filling to reduce turbulence until nearly filled. Then straighten vial to vertical for final filling. Ensure that a meniscus is raised above the lip of the vial before capping.
3. Cap each vial once the meniscus has formed.
4. Turn the capped vial upside down and check for air bubbles. Tap the bottom of the vials to dislodge any bubbles that may have formed around the cap or sides. Discard and resample if bubbles are present.
5. Wipe the outside of sample vials with a Kimwipe or clean paper towel. Affix a completed sample label.
6. Place sample vial(s) in a zip-top plastic bag and seal the bag.
7. Immediately pack all samples into a chilled cooler.
8. Check that a trip blank/temperature blank, when necessary, is included in the chilled cooler. Quality assurance/quality control requirements vary from project to project. Consult the project-specific work plan for quality requirements.

### **5.2.2 Method for Collecting Discrete Shallow Surface Water Samples for Nonvolatile Organic or Inorganic Compound Analysis**

The following steps must be followed when collecting discrete shallow surface water samples for nonvolatile organic or inorganic compound analysis:

1. Directly dip the sample container, with the opening facing upstream, into the surface water and fill. If wading is necessary, approach the sample location from downstream; do not enter the actual sample area. Do not disturb underlying sediments.
2. Filter samples if required by the site-specific plan.
3. Add appropriate preservatives to the sample containers if required and check pH.

**Note:** Use a separate container when field testing pH, conductivity, temperature, etc. Do not insert pH paper or probe directly into sample container.

4. Cap the sample containers and wipe the outer surfaces of the sample containers clean with a Kimwipe or clean paper towel. Affix a completed sample label.
5. Place sample container(s) in individual zip-top plastic bags, if possible, and seal the bags.
6. Immediately pack all samples into a chilled cooler.

**Lagoon Sampling**

SOP 1-14

Revision: 2

Date: February 2015

**5.2.3 Method for Collecting Simple Composite Shallow Surface Water Samples for Nonvolatile Organic or Inorganic Compound Analysis**

If the QAPP requires the use of simple composite samples, then a sampler capable of collecting composite samples is required. For width and depth integrated (WDI) composite samples, a DH-48 or DH-81 sampler is recommended, but the QAPP may specify an alternative. The following steps must be followed when collecting simple composite shallow surface water samples for nonvolatile organic or inorganic compound analysis:

1. Record the gage height, if any, before and after sampling.
2. Select the number of width increments based on the requirements of the QAPP. Generally, small well mixed streams require few increments while large or poorly mixed streams require more increments.
3. For fewer than six width increments, subsample locations can be visually estimated. For more than five width increments, string a tape measure across the stream above the water surface to be able to accurately identify the subsample locations. Increments should be evenly spaced across the stream for equal width-integrated (EWI) sampling.
4. If depth-integrated sampling is required, collect a subsample at each width increment by submerging the sampler, orifice facing upstream, from the surface to near the bottom and back up to the surface again in an even steady motion. Do not disturb the sediment at the bottom. The sampler should be retrieved less than full. If the sampler is full, empty it and repeat the subsample collection.
5. If depth-integrated sampling is not required, submerge the sampler with the orifice facing upstream into the surface water and fill.
6. Empty the sampler into a churn splitter or temporary container for later splitting.
7. Repeat Steps 4 to 6 for each width increment.
8. If temporary containers were used, empty into churn splitter. Operate the churn splitter by moving the churn up and down in a steady motion fast enough to homogenize the sample without causing aeration. While the churn is in motion, fill the sample bottles from the tap on the churn.
9. Follow Steps 2 through 6 in Section 5.2.2.

**5.2.4 Method for Collecting Temporal Composite Shallow Surface Water Samples for Nonvolatile Organic or Inorganic Compound Analysis**

If the QAPP requires the use of temporal composite samples, this can be accomplished using a series of discrete samples collected by hand or an automated sampler, or using a series of simple composite samples. Refer to the preceding sections for collecting the subsamples. The compositing scheme can be time-based (e.g., once per hour for 4 hours) or time-discharge (or time gage height) based (e.g., once per hour until the gage height exceeds xx feet, then change to once per 15 minutes).

Because of the project-specific nature of temporal composite sampling, the specific requirements should be identified in the QAPP. The following are general steps to be followed to collect temporal composite samples:

1. Provide for a method of measuring discharge or gage height before, during, and after sample collection as required in the QAPP.
2. Select the number of time increments based on the requirements of the QAPP. If the time increments change based on a change in flow or water quality, specify the trigger, the new time increment, and any additional trigger to return to the previous increment.

**Lagoon Sampling**

SOP 1-14

Revision: 2

Date: February 2015

3. Calculate the storage volume for the subsamples and provide a churn splitter of adequate size to contain the entire sample to be composited.
4. Collect the samples according to a method described in this SOP or alternate specified in the QAPP.
5. Provide for cold storage of subsamples, if possible. Do not process any subsamples by filtering or preserving unless specified in the QAPP.
6. Following collection of all subsamples, empty the containers into a churn splitter. If discrete data are required including laboratory or field analysis, retain a portion of the subsample.
7. Operate the churn splitter by moving the churn up and down in a steady motion fast enough to homogenize the sample without causing aeration. While the churn is in motion, fill the sample bottles from the tap on the churn.
8. Follow Steps 2 through 6 in Section 5.2.2.
9. Field parameters should be measured in the surface water at the time of collection. Some field parameters can be measured on the subsamples at the time of compositing, but the temperature and temperature-dependant parameters will not be representative.

**5.3 Deep Surface Water Sample Collection****5.3.1 Method for Collecting Samples at Specified Depth Using a Weighted Bottle Sampler**

The following steps must be followed when collecting surface water samples at specific depths using a weighted bottle sampler:

1. Lower the weighted bottle sampler to the depth specified in the site-specific plan.
2. Remove the stopper by pulling on the sampler line and allow the sampler to fill with water.
3. Release the sampler line to reseal the stopper and retrieve the sampler to the surface.
4. Wipe the weighted bottle sampler dry with a Kimwipe or clean paper towel.
5. Remove the stopper slowly. Fill the specified number of sample containers by slightly tipping the sampler against each sample bottle. Samples to be used for VOC analysis should be decanted directly from the sampler first into pre-preserved VOA vials. It is recommended that the amount of preservative be predetermined on a separate aliquot of sample that is subsequently discarded. Add appropriate preservatives to the other sample containers and check pH. Samples may be pooled in stainless steel, glass, or Teflon containers to obtain the necessary volumes. Filter samples if required. Collect sample in separate container for pH, conductivity, temperature, and other measurements if necessary.
6. Close each sample container with the Teflon-lined cap once it is filled. Check for air bubbles in the VOC sample containers. If bubbles are present, discard and resample.
7. Wipe the outside of the sample containers clean with a Kimwipe or clean paper towel. Affix a completed sample label.
8. Place sample container(s), if possible, in individual zip-top plastic bags and seal the bags.
9. Immediately pack all samples into a chilled cooler.

**5.3.2 Method for Deep Surface Water Sample Collection Using a Peristaltic Pump**

The following steps must be followed when collecting deep surface water samples using a peristaltic pump:

**Lagoon Sampling**

SOP 1-14

Revision: 2

Date: February 2015

1. Install clean medical-grade silicon or Teflon tubing on the pump head. Leave sufficient tubing on the discharge side for convenient dispensing of liquid directly into sample containers.
2. Select the appropriate length of Teflon intake tubing necessary to reach the specified sampling depth. Attach the intake sampling tube to the intake pump tube.
3. Lower the intake tube into the surface water at the specified sampling location to the specified depth; make sure the end of the intake tube does not touch underlying sediments.
4. Start the pump and allow at least three tubing volumes of liquid to flow through and rinse the system before collecting any samples. Do not immediately dispense the purged liquid back to the surface water body. Instead, collect the purged liquid and return it to the source after sample collection is complete.
5. Fill the specified number of sample containers directly from the discharge line. Filter samples if required by the site-specific plan. While filling, allow the liquid to flow gently down the inside of the sample bottle to minimize turbulence.

For VOC samples, fill pre-preserved VOA vials and allow a meniscus to form above the top of the container before capping. It is recommended that the amount of preservative be predetermined on a separate aliquot of sample that is subsequently discarded. Check VOA vials to ensure that there are no air bubbles. Add appropriate preservatives to the other samples and check pH.

**Note:** Use a separate container when field-testing pH, conductivity, temperature, etc. Do not insert pH paper or probe directly into sample container.

6. Cap the sample container(s). Wipe the outside of sample containers clean with a Kimwipe or clean paper towel. Affix a completed sample label.
7. Place sample container(s) in individual zip-top plastic bags and seal the bags.
8. Immediately pack all samples into a chilled cooler.
9. Drain the pump system, rinse it with deionized water, and wipe it dry. Replace all tubing with new tubing before sampling at another location. Place all used tubing in plastic bags to be discarded or decontaminated according to the site-specific plans.

**5.4 Preparation for Sampling Sediment/Sludge**

The following steps shall be taken when preparing for sampling sediment/sludge:

1. Review site-specific health and safety plan and project plans before initiating sampling activity.
2. Don the appropriate personal protective clothing as dictated by the site-specific health and safety plan.
3. Select lagoon sampling locations that exhibit cross-sectional homogeneity. Avoid areas where the channel is constricted or bends where scouring may have occurred. For lakes, collect sediment samples away from the shoreline.
4. Prepare sampling site by laying out clean plastic sheeting on the ground or any flat, level surface near the sampling area. Then place equipment to be used on the plastic sheeting.
5. If surface water is present at the sample location, make field measurements of physical, chemical, and biological characteristics of the water (e.g., temperature, dissolved oxygen, conductivity, pH), as dictated by the project-specific plans.
6. The samples shall be collected from areas of least to greatest contamination (when known). When collecting several samples in 1 day, always collect from downstream to upstream.

**Lagoon Sampling**

SOP 1-14

Revision: 2

Date: February 2015

7. When sampling sediment and surface water from the same surface water body, collect surface water samples before sediment samples.
8. Document the sampling events, recording all information in the designated field logbook and take photographs (if required). Document any and all deviations from this SOP and include rationale for changes.
9. The collection points should be located on a site map and described in the field logbook. Use GPS if required or if possible.
10. Label each sample container with the appropriate information. Secure the label by covering it with a piece of waterproof clear tape.
11. Decontaminate reusable sampling equipment after sample collection according to SOP 4-5.
12. Processes for verifying depth of samples must be included in site-specific project plans.
13. Check that a trip blank/temperature blank, when necessary, is included in the chilled cooler. Quality assurance/quality control requirements vary from project to project. Consult the project-specific work plan for quality requirements.

**5.5 Sediment/Sludge Sample Collection from Shallow Waters****5.5.1 Method for Collecting Samples for Volatile Organic Compound (VOC) Analysis**

The following steps must be followed when collecting shallow water sediment/sludge VOC samples:

1. Use a decontaminated stainless steel or Teflon, long-handled scoop, corer, push tube, or dredge to collect the entire sample in one grab. If wading is necessary, approach the sample location from downstream. Do not enter the actual sample area.
2. Retrieve the sampling device and slowly decant off any liquid.
3. Immediately fill the specified sample container(s) with the solid. Use a clean stainless steel or Teflon spoon or spatula to completely fill the container(s), ensuring no headspace.

**Note:** Samples to be analyzed for VOCs or other compounds degraded by aeration should be taken as grab samples. Do not homogenize or composite these samples.

4. Once each container is filled, close the container with the Teflon-lined cap. Wipe the outside of the container clean with a Kimwipe or clean paper towel. Affix a completed sample label.
5. Place the sample container(s) in individual zip-top plastic bags and seal the bags.
6. Immediately pack all samples into a chilled cooler.

**5.5.2 Method for Collecting Samples for Nonvolatile Organic and Inorganic Compound Analysis**

The following steps must be taken when collecting shallow water sediment/sludge samples for analytes not degraded by aeration:

1. Collect sufficient volume to fill specified sample containers using decontaminated stainless steel or Teflon-lined equipment (e.g., scoops, corer, dredge sampler, etc.). If wading is necessary, approach the sample location from downstream. Do not enter the actual sample area.
2. Retrieve the sampling device with the sample and slowly decant off any liquid.
3. Pool and homogenize samples in a stainless steel, Teflon, or appropriate pan or mixing bowl, using stainless steel spatula or spoon.



**Lagoon Sampling**

SOP 1-14

Revision: 2

Date: February 2015

4. Fill each sample container with the homogenized sample to approximately 75 to 90 percent capacity, filling sample containers for organic analyses first.
5. Once each container is filled, close the container with a Teflon-lined cap. Wipe the outside of sample containers clean with a Kimwipe or clean paper towel. Affix a completed sample label.
6. Place the sample container(s) in individual zip-top plastic bags and seal the bags.
7. Immediately pack all samples into a chilled cooler.

**5.6 Subsurface Sediment/Sludge Sample Collection Using a Corer or Auger from Shallow Waters****5.6.1 Method for Collecting Samples for Volatile Organic Compound Analysis Using an Unlined Corer**

(also applies to augers)

The following steps must be taken when collecting subsurface sediment/sludge VOC samples that underlie shallow water:

1. At the specified sampling location, force or drive the corer to the specified depth.
2. Twist and withdraw the corer in a smooth motion.
3. Retrieve the sampling device, remove the corer nosepiece (if possible), and extrude the sample into the specified sampling container(s). Use a clean stainless steel or Teflon spoon or spatula to completely fill the container(s), ensuring no headspace.
4. Once each container is filled, close the container with the Teflon-lined cap. Wipe the outside of the sample container clean with a Kimwipe or clean paper towel. Affix a completed sample label.
5. Place the sample container(s) in individual zip-top plastic bags and seal the bags.
6. Immediately pack all samples into a chilled cooler.

**5.6.2 Method for Collecting Samples for Volatile Organic Compound Analysis Using a Lined Corer**

The following steps must be followed when collecting shallow water subsurface sediment/sludge VOC samples that underlie shallow water:

1. Install decontaminated liner(s) in the corer barrel.
2. At the specified sampling location, force or drive the corer to the specified depth.
3. Twist and withdraw the corer in a smooth motion.
4. Retrieve the sampling device, remove the corer nosepiece (if possible) and remove the liner(s), cap the liner(s), and seal the caps with Teflon tape.
5. Wipe the outside of the liner clean with a Kimwipe or clean paper towel. Label the top and bottom ends of the liner(s). Affix a completed sample label.
6. Place capped and sealed liners in individual zip-top plastic bags and seal the bags.
7. Immediately pack all samples into a chilled cooler.

**Lagoon Sampling**

SOP 1-14

Revision: 2

Date: February 2015

**5.6.3 Method for Collecting Samples for Nonvolatile Organic and Inorganic Compound Analysis Using a Corer** (also applies to augers)

The following steps must be followed when collecting subsurface sediment/sludge samples that underlie shallow water for analytes not degraded by aeration:

1. At the specified sampling location, force or drive the corer to the specified depth.
2. Twist and withdraw the corer in a smooth motion.
3. Retrieve the sampling device. Remove the corer nosepiece (if possible) and extrude the sample into a stainless steel or Teflon-lined pan or bowl. Collect sufficient sample volume to fill all containers.
4. Use a stainless steel or Teflon spoon or spatula to homogenize and then divide the sample material into the appropriate number of sample containers.
5. Fill each container to approximately 75 to 90 percent capacity, filling containers for organic analyses first. Close the container with a Teflon-lined cap. Wipe the outside of sample containers clean with a Kimwipe or clean paper towel. Affix a completed sample label.
6. Place the sample container(s) in individual zip-top plastic bags and seal the bags.
7. Immediately pack all samples into a chilled cooler.

**5.7 Sediment/Sludge Sample Collection Using a Dredge from Deep Waters****5.7.1 Method for Collecting Samples for Volatile Organic Compound Analysis**

The following steps must be followed when collecting deep-water sediment/sludge VOC samples:

1. Attach a clean piece of ½- to ¾-inch (12- to 19-mm) braided nylon line or Teflon-coated wire rope to the top of the sampler. The line must be of sufficient length to reach the sediment or sludge and have enough slack to release the mechanism. Mark the distance to the bottom on the line.
2. Attach the free end of the sampling line to a fixed support to prevent loss of the sampler.
3. At the specified sampling location, open the sampler jaws and slowly lower the sampler until contact with the bottom (sediment/sludge) is felt.
4. Release tension on the line and allow sufficient slack for the mechanism (latch) to release. Slowly raise the sampler.
5. Once the sampler is above the water surface, place the sampler in a decontaminated stainless steel or Teflon-lined tray or pan. Open the sampler. Immediately collect the sample for VOC analysis, using a stainless steel or Teflon spoon or spatula. Fill each container completely to minimize headspace.
6. Once each container is filled, close the container with the Teflon-lined cap. Wipe the outside of sample containers clean with a Kimwipe or clean paper towel. Affix a completed sample label.
7. Place the sample container(s) in individual zip-top plastic bags and seal the bags.
8. Immediately pack all samples into a chilled cooler.

**Lagoon Sampling**

SOP 1-14

Revision: 2

Date: February 2015

**5.7.2 Method for Collecting Samples for Nonvolatile Organic and Inorganic Compounds**

The following steps must be followed when collecting deep-water sediment/sludge samples for analytes not degraded by aeration:

1. Attach a clean piece of ½- to ¾-inch (12- to 19-mm) braided nylon line or Teflon-coated wire rope to the top of the sampler. The line must be of sufficient length to reach sediment or sludge and have enough slack to release the mechanism. Mark the distance to the bottom on the line.
2. Attach the free end of the sampling line to a fixed support to prevent loss of the sampler.
3. At the specified sampling location, open the sampler jaws and slowly lower the sampler until contact with the bottom (sediments/sludge) is felt.
4. Release tension on the line and allow sufficient slack for the mechanism (latch) to release. Slowly raise the sampler.
5. Once the sampler is above the water surface, place the sampler in a decontaminated stainless steel or Teflon-lined tray or pan. Open the sampler.
6. Collect sufficient volume of sample to fill the specified sampler containers. Pool the grab samples in a tray, pan, or bowl. Homogenize the pooled samples by mixing them together with a stainless steel or Teflon spoon or spatula.
7. Fill the specified sample containers to approximately 75 to 90 percent capacity with the homogenized sample using the stainless steel or Teflon spoon or spatula. Fill sample containers for organic analyses first.
8. Once each container is filled, close the container with the Teflon-lined cap. Wipe the outside of sample containers clean with a Kimwipe or clean paper towel. Affix a completed sample label.
9. Place sample container(s) in individual zip-top plastic bags and seal the bags.
10. Immediately pack all samples into a chilled cooler.

**6.0 Restrictions/Limitations**

Peristaltic pumps are generally not capable of lifting water distances greater than 20 to 25 feet (6 to 7.5 meters) above the normal hydrostatic level.

Core sampling devices may not be usable if cobbles exist in the sediment/sludge. Bumping of core sampling devices and Ponar dredge samplers may result in the loss of some of the sample.

Grab sampling for VOC analysis or for analysis of any other compound(s) that may be degraded by aeration is necessary to minimize sample disturbance and, hence, analyte loss. The representativeness of this sample, however, is difficult to determine because the collected sample represents a single point, is not homogenized, and has been disturbed.

**Lagoon Sampling**

SOP 1-14  
Revision: 2  
Date: February 2015

**7.0 References**

U. S. Environmental Protection Agency, Region 2. *CERCLA Quality Assurance Manual*. March 1988 or current revision.

U. S. Geological Survey. *National Field Manual for the Collection of Water-Quality Data, Chapter A4*. September 1999. Updates are available at: [http://water.usgs.gov/owq/FieldManual/chapter4/html/Ch4\\_contents.html](http://water.usgs.gov/owq/FieldManual/chapter4/html/Ch4_contents.html)

\_\_\_\_\_. A guide to the Proper Selection and Use of Federally Approved Sediment and Water Quality Samplers. Open-File Report 2005-1087. 2005.

2014. Region 4. The Field Branches Quality System and Technical Procedures, Sediment Sampling. SESDPROC-200-R3. August.

**Packaging and Shipping Environmental Samples**

SOP 2-1

Revision: 6

Date: February 2015

Approved:

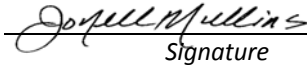
  
Signature

Technical Review:

T. Burgesser/C. Zakowski

**1.0 Objective**

The objective of this technical standard operating procedure (SOP) is to outline the requirements for the packaging and shipment of environmental samples. Additionally, Sections 2.0 through 7.0 outline requirements for the packaging and shipping of regulated environmental samples under the Department of Transportation (DOT) Hazardous Materials Regulations, the International Air Transportation Association (IATA), and International Civil Aviation Organization (ICAO) Dangerous Goods Regulations for shipment by air and applies only to domestic shipments. This SOP does not cover the requirements for packaging and shipment of equipment (including data loggers and self-contained breathing apparatus [SCBAs] or bulk chemicals that are regulated under the DOT, IATA, and ICAO.

**1.1 Packaging and Shipping of All Samples**

This SOP applies to the packaging and shipping of all environmental samples. If the sample is preserved or radioactive, the following sections may also be applicable.

- Section 2.0 - Packaging and Shipping Samples Preserved with Methanol
- Section 3.0 - Packaging and Shipping Samples Preserved with Sodium Hydroxide
- Section 4.0 - Packaging and Shipping Samples Preserved with Hydrochloric Acid
- Section 5.0 - Packaging and Shipping Samples Preserved with Nitric Acid
- Section 6.0 - Packaging and Shipping Samples Preserved with Sulfuric Acid
- Section 7.0 - Packaging and Shipping Limited-Quantity Radioactive Samples

NOTE: This SOP does not address shipment of hazardous materials. Don't ship a hazardous material unless you have received training that meets the requirements of CDM Smith and the DOT. Check with CDM Smith University for training courses.

**1.2 Background****1.2.1 Definitions**

**Environmental Sample** - An aliquot of air, water, plant material, sediment, or soil that represents the contaminant levels on a site. Samples of potential contaminant sources, like tanks, lagoons, or non-aqueous phase liquids are normally not "environmental" for this purpose. This procedure applies only to environmental samples that contain less than reportable quantities for any foreseeable hazardous constituents according to DOT regulations promulgated in 49 CFR - Part 172.101 Appendix A.

**Custody Seal** - A custody seal is a narrow adhesive-backed seal that is applied to individual sample containers and/or the container (i.e., cooler) before offsite shipment. Custody seals are used to demonstrate that sample integrity has not been compromised during transportation from the field to the analytical laboratory.

**Inside Container** - The container, normally made of glass or plastic, that actually contacts the shipped material. Its purpose is to keep the sample from mixing with the ambient environment.

**Outside Container** - The container, normally made of metal or plastic, that the transporter contacts. Its purpose is to protect the inside container.

**Secondary Containment** - The outside container provides secondary containment if the inside container breaks (i.e., plastic overpackaging if liquid sample is collected in glass).

**Excepted Quantity** - Excepted quantities are limits to the mass or volume of a hazardous material in the inside and outside containers below which DOT, IATA, ICAO regulations do not apply. The excepted quantity limits are very low. Most regulated shipments will be made under limited quantity.

## Packaging and Shipping Environmental Samples

SOP 2-1

Revision: 6

Date: February 2015

**Limited Quantity** - Limited quantity is the maximum amount of a hazardous material below which there are specific labeling or packaging exceptions.

**Performance Testing** - Performance testing is the required testing of outer packaging. These tests include drop and stacking tests.

**Qualified Shipper** - A qualified shipper is a person who has been adequately trained to perform the functions of shipping hazardous materials.

### 1.2.2 Associated Procedures

- SOP 1-2, *Sample Custody*

### 1.2.3 Discussion

Proper packaging and shipping is necessary to ensure the protection of the integrity of environmental samples shipped for analysis. These shipments are potentially subject to regulations published by DOT, IATA, or ICAO. Failure to abide by these rules places both CDM Smith and the individual employee at risk of serious fines. The analytical holding times for the samples must not be exceeded. The samples shall be packed in time to be shipped for overnight delivery. Make arrangements with the laboratory before sending samples for weekend delivery.

### 1.3 Required Equipment

- Coolers with return address of the appropriate CDM Smith office
- Heavy-duty plastic garbage bags
- Plastic zip-type bags, small and large
- Clear tape
- Nylon reinforced strapping tape
- Duct tape
- Kitty litter/pine bedding (or an equivalent nonflammable material that is inert and absorbent)\*
- Bubble wrap (optional)
- Ice
- Custody seals
- Completed chain-of-custody record or contract laboratory program (CLP) custody records, if applicable
- Completed bill of lading
- This End Up and directional arrow labels

\*Check for any client-specific or laboratory requirements related to the use of absorbent packaging materials.

### 1.4 Packaging Environmental Samples

The following steps must be followed when packing sample bottles and jars for shipment:

1. Verify the samples undergoing shipment meet the definition of "environmental sample" and are not a hazardous material as defined by DOT. Professional judgment and/or consultation with qualified persons such as the appropriate health and safety coordinator or the health and safety manager shall be observed.
2. Select a sturdy cooler in good repair. Tape any interior opening in the cooler (drain plug) from the inside to ensure control of interior contents. Ensure the handles used for carrying the cooler are in good repair. Also, tape the drain plug from the outside of the cooler. Line the cooler with a large heavy-duty plastic garbage bag.
3. Be sure the caps on all bottles are tight (will not leak); check to see that labels and chain-of-custody records are completed properly (SOP 1-2, *Sample Custody*).
4. Place all bottles in separate and appropriately sized plastic zip-top bags and close the bags. Up to three volatile organic analyte (VOA) vials may be packed in one bag. Binding the vials together with a rubber band on the outside of the bag, or separating them so that they do not contact each other, will reduce the risk of breakage. VOA vials may be packaged in foam containers designed for packaging them as well. Bottles may be wrapped in bubble wrap. Optionally, place three to six VOA vials in a quart metal can and then fill the can with kitty litter/pine bedding or equivalent. **Note:** Trip blanks must be included in coolers containing VOA samples.

## Packaging and Shipping Environmental Samples

SOP 2-1

Revision: 6

Date: February 2015

5. Place 2 to 4 inches of an absorbent material into a cooler that has been lined with a garbage bag, and then place the bottles and cans in the bag with sufficient space to allow for the addition of packing material between the bottles and cans. It is preferable to place glass sample bottles and jars into the cooler vertically. Glass containers are less likely to break when packed vertically rather than horizontally.
6. While placing sample containers into the cooler, conduct an inventory of the contents of the shipping cooler against the chain-of-custody record. The chain-of-custody with the cooler shall reflect only those samples within the cooler.
7. Put ice in large plastic zip-top bags (double bagging the zip-tops is preferred) and properly seal. Place the ice bags on top of and/or between the samples. Several bags of ice are required (dependant on outdoor temperature, staging time, etc.) to maintain the cooler temperature at approximately 4° Celsius (C) if the analytical method requires cooling. Fill all remaining space between the bottles or cans with packing material. Securely fasten the top of the large garbage bag with fiber or duct tape.
8. Place the completed chain-of-custody record or the CLP traffic report form (if applicable) for the laboratory into a plastic zip-top bag, seal the bag, tape the bag to the inner side of the cooler lid and close the cooler.
9. The cooler lid shall be secured with nylon reinforced strapping tape by wrapping each end of the cooler a minimum of two times. Attach a completed chain-of-custody seal across the opening of the cooler on opposite sides. The custody seals shall be affixed to the cooler with half of the seal on the strapping tape so that the cooler cannot be opened without breaking the seal. Complete two more wraps around with fiber tape and place clear tape over the custody seals.
10. The shipping container lid must be marked **“THIS END UP”** and arrow labels that indicate the proper upward position of the container shall be affixed to the cooler. A label containing the name and address of the shipper (CDM Smith) shall be placed on the outside of the container. Labels used in the shipment of hazardous materials (such as Cargo Only Air Craft, Flammable Solids, etc.) are not permitted on the outside of containers used to transport environmental samples and shall not be used. The name and address of the laboratory shall be placed on the container, or when shipping by common courier, the bill of lading shall be completed and attached to the lid of the shipping container.

## 2.0 Packaging and Shipping Samples Preserved with Methanol

### 2.1 Containers

1. The maximum volume of methanol in a sample container is limited to 30 milliliters (ml).
2. The sample container must not be full of methanol.

### 2.2 Responsibility

It is the responsibility of the qualified shipper to:

1. Ensure that the samples undergoing shipment contain no other contaminant that meets the definition of “hazardous material” as defined by DOT.
2. Determine the amount of preservative in each sample so that accurate determination of quantities can be made.

**Note:** Responsibilities may vary from site to site. Therefore, all field team member responsibilities shall be defined in the field plan or site-/project-specific quality assurance project plan (QAPP).

### 2.3 Additional Required Equipment

The following equipment is needed in addition to the required equipment listed in Section 1.3:

1. Inner packing may consist of glass or plastic jars

**Packaging and Shipping Environmental Samples**

SOP 2-1

Revision: 6

Date: February 2015

2. Outer packaging (for limited quantities) insulated cooler that has passed the ICAO drop test
3. Survey documentation (if shipping from Department of Energy [DOE] or radiological sites)
4. Class 3 flammable liquid labels
5. Orientation labels
6. Consignor/consignee labels

**2.4 Packaging Samples Preserved with Methanol**

The following steps are to be followed when packaging limited-quantity sample shipments:

1. Tape any interior opening in the cooler (drain plug) from the inside to ensure control of interior contents. Also, tape the drain plug from the outside of the cooler.
2. All sample containers will be properly labeled and the label protected with waterproof tape before sampling.

At a minimum the label must contain:

- |                                      |   |
|--------------------------------------|---|
| ▪ Project name                       | ▪ Sample identification number  |
| ▪ Project number                     | ▪ Collector's initials  |
| ▪ Date and time of sample collection | ▪ Preservative (note amount of preservative used in miscellaneous section of the chain-of-custody form) |
| ▪ Sample location                    |   |

3. Wrap each container (40-ml VOA vials) in bubble wrap (secure with waterproof tape) to prevent breakage.
4. Place the bubble-wrapped container into a 2.7-mil zip-type bag, removing trapped air.
5. Place wrapped containers inside a polyethylene bottle filled with an absorbent; seal the bottle. (Maximum of 4 VOA vials will fit inside a 500-ml wide-mouth polyethylene bottle.)
6. Total volume of methanol per shipping container must not exceed 500 ml.
7. Place sufficient amount of an absorbent in the bottom of the cooler to absorb any leakage that may occur.
8. Place a garbage bag in the cooler.
9. Pack the samples appropriately inside the garbage bag (bottles placed upright) to prevent movement during shipment.
10. Place a sufficient amount of double-bagged ice around the samples to maintain the required temperature during shipment.
11. Seal the garbage bag by tying or taping.
12. The maximum weight of the cooler shall not exceed 30 kg (66 lbs) for any limited-quantity shipment of dangerous goods.
13. Secure the chain-of-custody form (placed inside a zip-type bag) to the interior of the cooler lid.
14. If the shipment is from a DOE or other facility, place the results of the radiation screen and cooler/sample survey with the chain-of-custody.



## Packaging and Shipping Environmental Samples

SOP 2-1

Revision: 6

Date: February 2015

15. Wrap strapping tape or duct tape around both ends of the cooler and around the cooler lid.
16. Affix custody seals to opposite sides of the cooler lid. Cover the custody seals with clear waterproof tape.
17. Mark the outside of the cooler with the proper shipping name of the contents, corresponding UN number, and LTD. QTY. (as shown below).

**Methanol Mixture**  
**UN1230**  
**LTD. QTY.**

18. Place a label on the front of the cooler with the company name, contact name, phone number, full street address, and state with zip code for both shipper and recipient.
19. Affix a Flammable Liquid label to the outside of the cooler.
20. Affix package orientation labels on two opposite sides of the cooler.
21. Secure the marking and labels to the surface of the cooler with clear waterproof tape to prevent accidental removal during shipment. An example of cooler labeling/marketing locations is shown in Figure 1.

**Note:** No marking or labeling can be obscured by strapping or duct tape.

**Note:** The inner packaging of dangerous goods must be placed into the designated cooler for shipment. Other nonregulated environmental samples may be added to the cooler for shipment.

22. When shipping from a DOE facility, the cooler will be surveyed by a qualified radiation control technician to ensure that radiation flux on exterior surfaces does not exceed 0.5 millirem/hour (mrem/h) on all sides. This survey will be documented and the results reviewed by the qualified shipper.
23. Complete the Dangerous Goods and Hazardous Materials Inspection Checklist for Shipping Limited-Quantity(Appendix A).
24. Complete a Dangerous Goods Airbill.

**Figure 1**  
**Example of Cooler Label/Marking Locations**

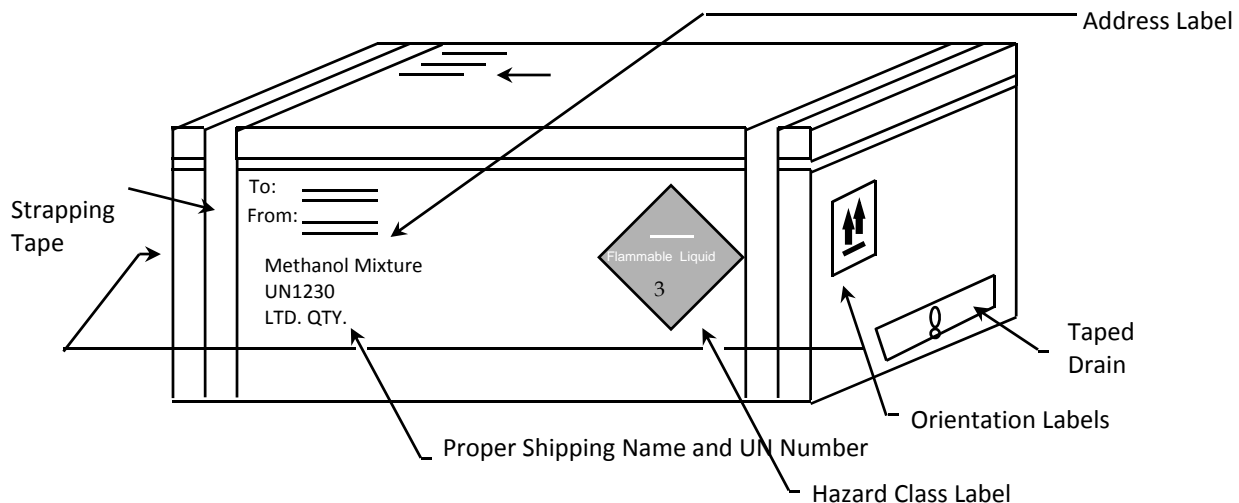

## Packaging and Shipping Environmental Samples

SOP 2-1

Revision: 6

Date: February 2015

### 3.0 Packaging and Shipping Samples Preserved with Sodium Hydroxide

#### 3.1 Containers

The inner packaging container (and amount of preservative) that may be used for these shipments includes:

Excepted Quantities of Sodium Hydroxide Preservatives

| Preservative |     | Desired in Final Sample |       | Quantity of Preservative (ml) for Specified Container |        |        |        |     |
|--------------|-----|-------------------------|-------|---|--------|--------|--------|-----|
|              |     | pH                      | Conc. | 40 ml   | 125 ml | 250 ml | 500 ml | 1 L |
| NaOH         | 30% | >12                     | 0.08% |   | .25    | 0.5    | 1      | 2   |

5 drops = 1 ml

#### 3.2 Responsibility

It is the responsibility of the qualified shipper to determine the amount of preservative in each sample so that accurate determination of quantities can be made.

**Note:** Responsibilities may vary from site to site. Therefore, all field team member responsibilities shall be defined in the field plan or site-/project-specific QAPP.

#### 3.3 Additional Required Equipment

The following equipment is needed in addition to the required equipment listed in Section 1.3:

- Outer packaging (for limited quantities) insulated cooler that has passed the ICAO drop test
- Inner packings may consist of glass or plastic jars no larger than 1 pint
- Survey documentation (if shipping from DOE or radiological sites)
- Class 8 corrosive labels
- Orientation labels
- Consignor/consignee labels

#### 3.4 Packaging Samples Preserved with Sodium Hydroxide

Samples containing sodium hydroxide (NaOH) as a preservative that exceed the excepted concentration of 0.08 percent (2 ml of a 30 percent NaOH solution per liter) may be shipped as a limited quantity per packing instruction Y819 of the IATA/ICAO Dangerous Goods Regulations.

The following steps are to be followed when packaging limited-quantity samples shipments:

1. Tape any interior opening in the cooler (drain plug) from the inside to ensure control of interior contents. Also, tape the drain plug from the outside of the cooler.
2. All sample containers will be properly labeled and the label protected with waterproof tape before sampling.

At a minimum the label must contain:

- Project name
  - Project number
  - Date and time of sample collection
  - Sample location
  - Sample identification number
  - Collector's initials
  - Preservative (note amount of preservative used in miscellaneous section of the chain-of-custody form)
3. This step is optional; wrap each container in bubble wrap (secure with waterproof tape) to prevent breakage.

**Packaging and Shipping Environmental Samples**

SOP 2-1

Revision: 6

Date: February 2015

4. Place the bubble-wrapped container into a 2.7-mil zip-type bag, removing trapped air.
5. Place glass containers inside a polyethylene bottle filled with an absorbent; seal the bottle.
6. The total volume of sample in each cooler must not exceed 1 liter.
7. Place sufficient amount of an absorbent in the bottom of the cooler to absorb any leakage that may occur.
8. Place a garbage bag in the cooler.
9. Pack the samples appropriately inside the garbage bag (bottles placed upright) to prevent movement during shipment.
10. Place sufficient amount of double-bagged ice around the samples to maintain the required temperature during shipment.
11. Seal the garbage bag by tying or taping.
12. The maximum weight of the cooler shall not exceed 30 kg (66 lbs) for any limited-quantity shipment of dangerous goods.
13. Secure the chain-of-custody form (placed inside a zip-type bag) to the interior of the cooler lid.
14. If the shipment is from a DOE or other facility, place the results of the radiation screen and cooler/sample survey with the chain-of-custody.
15. Wrap strapping tape or duct tape around both ends of the cooler and around the cooler lid.
16. Affix custody seals to opposite sides of the cooler lid. Cover the custody seals with clear waterproof tape.
17. Mark the outside of the cooler with the proper shipping name of the contents, corresponding UN number, and LTD. QTY. (as shown below).

**Sodium Hydroxide Solution**  
**UN1824**  
**LTD. QTY.**

18. Place a label on the front of the cooler with the company name, contact name, phone number, full street address, and state with zip code for both shipper and recipient.
19. Affix a Corrosive label to the outside of the cooler.
20. Affix package orientation labels on two opposite sides of the cooler.
21. Secure the marking and labels to the surface of the cooler with clear waterproof tape to prevent accidental removal during shipment. An example of cooler labeling/marketing locations is shown in Figure 1.

**Note:** Samples meeting the exception concentration of 0.08 percent NaOH by weight may be shipped as nonregulated or nonhazardous following the procedure in Section 1.4.

**Note:** No marking or labeling can be obscured by strapping or duct tape.

**Note:** The inner packaging of dangerous goods must be placed into the designated cooler for shipment. Other nonregulated environmental samples may be added to the cooler for shipment.

**Packaging and Shipping Environmental Samples**

SOP 2-1

Revision: 6

Date: February 2015

22. When shipping from a DOE facility, the cooler will be surveyed by a qualified radiation control technician to ensure that radiation flux on exterior surfaces does not exceed 0.5 mrem/h on all sides. This survey will be documented and the results reviewed by the qualified shipper.
23. Complete the Dangerous Goods and Hazardous Materials Inspection Checklist for Shipping Limited-Quantity (Appendix A).
24. Complete a Dangerous Goods Air Bill.

**4.0 Packaging and Shipping Samples Preserved with Hydrochloric Acid****4.1 Containers**

The inner packaging container (and amount of preservative) that may be used for these shipments includes:

**Excepted Quantities of Hydrochloric Acid Preservatives**

| <i>Preservative</i> |    | <i>Desired in Final Sample</i> |              | <i>Quantity of Preservative (ml) for Specified Container</i> |               |               |
|---------------------|----|--------------------------------|--------------|--|---------------|---------------|
|                     |    | <i>pH</i>                      | <i>Conc.</i> | <i>40 ml</i>   | <i>125 ml</i> | <i>250 ml</i> |
| HCl                 | 2N | <1.96                          | 0.04%        | .2   | .5            | 1             |

5 drops = 1 ml

**4.2 Responsibility**

It is the responsibility of the qualified shipper to:

- Determine the samples undergoing shipment contain no other contaminant that meets the definition of hazardous material as defined by DOT.
- Determine the amount of preservative in each sample so that accurate determination of quantities can be made.

**Note:** Responsibilities may vary from site to site. Therefore, all field team member responsibilities shall be defined in the field plan or site-/project-specific QAPP.

**4.3 Additional Required Equipment**

The following equipment is needed in addition to the required equipment listed in Section 1.3.

- Inner packing may consist of glass or plastic jars no larger than 1 pint.
- Outer packaging (for limited quantities) insulated cooler that has passed the ICAO drop test.
- Survey documentation (if shipping from DOE or radiological sites)
- Class 8 corrosive labels
- Orientation labels
- Consignor/consignee labels

**4.4 Packaging Samples Preserved with Hydrochloric Acid**

The following steps are to be followed when packaging limited-quantity sample shipments:

1. Tape any interior opening in the cooler (drain plug) from the inside to ensure control of interior contents. Also, tape the drain plug from the outside of the cooler.
2. All sample containers will be properly labeled and the label protected with waterproof tape before sampling.

**Packaging and Shipping Environmental Samples**

SOP 2-1

Revision: 6

Date: February 2015

At a minimum the label must contain:

- Project name
  - Project number
  - Date and time of sample collection
  - Sample location
  - Sample identification number
  - Collector's initials
  - Preservative (note amount of preservative used in miscellaneous section of the chain-of-custody form)
- Wrap each container (40-ml VOA vials) in bubble wrap (secure with waterproof tape) to prevent breakage.
  - Place the bubble-wrapped container into a 2.7-mil zip-type bag, removing trapped air.
  - Place wrapped containers inside a polyethylene bottle filled with an absorbent; seal the bottle. (No more than 4 VOA vials will fit inside a 500-ml wide-mouth polyethylene bottle.)
  - Total volume of sample inside each cooler must not exceed 1 liter.
  - Place sufficient amount of an absorbent in the bottom of the cooler to absorb any leakage that may occur.
3. Place a garbage bag in the cooler.
  4. Pack the samples appropriately inside the garbage bag (bottles placed upright) to prevent movement during shipment.
  5. Place sufficient amount of double-bagged ice around the samples to maintain the required temperature during shipment.
  6. Seal the garbage bag by tying or taping.
  7. The maximum weight of the cooler shall not exceed 30 kg (66 lbs) for any limited-quantity shipment of dangerous goods.
  8. Secure the chain-of-custody form (placed inside a zip-type bag) to the interior of the cooler lid.
  9. If the shipment is from a DOE or other facility, place the results of the radiation screen and cooler/sample survey with the chain-of-custody.
  10. Wrap strapping tape or duct tape around both ends of the cooler and around the cooler lid.
  11. Affix custody seals to opposite sides of the cooler lid. Cover the custody seals with clear waterproof tape.
  12. Mark the outside of the cooler with the proper shipping name of the contents, corresponding UN number, and LTD. QTY. (as shown below).
 

**Hydrochloric Acid Solution**  
**UN1789**  
**LTD. QTY.**
  13. Place a label on the front of the cooler with the company name, contact name, phone number, full street address, and state with zip code for both shipper and recipient.
  14. Affix a Corrosive label to the outside of the cooler.
  15. Affix package orientation labels on two opposite sides of the cooler.

## Packaging and Shipping Environmental Samples

SOP 2-1

Revision: 6

Date: February 2015

16. Secure the marking and labels to the surface of the cooler with clear waterproof tape to prevent accidental removal during shipment. An example of cooler labeling/marketing locations is shown in Figure 1.

**Note:** Samples containing less than the exception concentration of 0.04 percent HCl by weight will be shipped as nonregulated or nonhazardous following the procedure in Section 1.4.

**Note:** No marking or labeling can be obscured by strapping or duct tape.

**Note:** The inner packaging of dangerous goods must be placed into the designated cooler for shipment. Other nonregulated environmental samples may be added to the cooler for shipment.

17. When shipping from a DOE facility, the cooler will be surveyed by a qualified radiation control technician to ensure that radiation flux on exterior surfaces does not exceed 0.5 mrem/h on all sides. This survey will be documented and the results reviewed by the qualified shipper.

18. Complete the Dangerous Goods and Hazardous Materials Inspection Checklist for Shipping Limited-Quantity (Appendix A).

19. Complete a Dangerous Goods Airbill.

## 5.0 Packaging and Shipping Samples Preserved with Nitric Acid

### 5.1 Containers

The inner packaging container (and amount of preservative) that may be used for these shipments includes:

**Excepted Quantities of Nitric Acid Preservatives**

| Preservative     |    | Desired in Final Sample |       | Quantity of Preservative (ml) for Specified Container |        |        |        |     |
|------------------|----|-------------------------|-------|---|--------|--------|--------|-----|
|                  |    | pH                      | Conc. | 40 ml   | 125 ml | 250 ml | 500 ml | 1 L |
| HNO <sub>3</sub> | 6N | <1.62                   | 0.15% |   | 2      | 4      | 5      | 8   |

5 drops = 1 mg/L

### 5.2 Responsibility

It is the responsibility of the qualified shipper to:

1. Determine the samples undergoing shipment contain no other contaminant that meets the definition of hazardous material as defined by DOT.
2. Determine the amount of preservative in each sample so that accurate determination of quantities can be made.

**Note:** Responsibilities may vary from site to site. Therefore, all field team member responsibilities shall be defined in the field plan or site-/project-specific QAPP.

### 5.3 Additional Required Equipment

The following equipment is needed in addition to the required equipment listed in Section 1.3:

- Inner packings may consist of glass or plastic jars no larger than 100 ml.
- Outer packaging (for limited quantities) insulated cooler that has passed the ICAO drop test.
- Survey documentation (if shipping from DOE or radiological sites)
- Class 8 corrosive labels
- Orientation labels
- Consignor/consignee labels

**Packaging and Shipping Environmental Samples**

SOP 2-1

Revision: 6

Date: February 2015

**5.4 Packaging Samples Preserved with Nitric Acid**

Samples containing nitric acid (HNO<sub>3</sub>) as a preservative that exceed the excepted concentration of 0.15 percent HNO<sub>3</sub> will be shipped as a limited quantity per packing instruction Y807 of the IATA/ICAO Dangerous Goods Regulations.

The following steps are to be followed when packaging limited-quantity sample shipments:

1. Tape any interior opening in the cooler (drain plug) from the inside to ensure control of interior contents. Also, tape the drain plug from the outside of the cooler.
2. All sample containers will be properly labeled and the label protected with waterproof tape before sampling.
 

At a minimum the label must contain:

|                                      |   |
|--------------------------------------|---|
| ▪ Project name                       | ▪ Sample identification number  |
| ▪ Project number                     | ▪ Collector's initials  |
| ▪ Date and time of sample collection | ▪ Preservative (note amount of preservative used in miscellaneous section of the chain-of-custody form) |
| ▪ Sample location                    |   |
3. This step is optional; wrap each container in bubble wrap (secure with waterproof tape) to prevent breakage.
4. Place the bubble-wrapped container into a 2.7-mil zip-type bag, removing trapped air.
5. Place glass containers inside a polyethylene bottle filled with an absorbent; seal the bottle.
6. Place sufficient amount of an absorbent in the bottom of the cooler to absorb any leakage that may occur.
7. Place a garbage bag in the cooler.
8. Pack the samples appropriately inside the garbage bag (bottles placed upright) to prevent movement during shipment.
9. Place sufficient amount of double-bagged ice around the samples to maintain the required temperature during shipment.
10. Seal the garbage bag by tying or taping.
11. The maximum volume of preserved solution in the cooler must not exceed 500 ml.
12. The maximum weight of the cooler shall not exceed 30 kg (66 lbs) for any limited-quantity shipment of dangerous goods.
13. Secure the chain-of-custody form (placed inside a zip-type bag) to the interior of the cooler lid.
14. If the shipment is from a DOE or other facility, place the results of the radiation screen and cooler/sample survey with the chain-of-custody.
15. Wrap strapping tape or duct tape around both ends of the cooler and around the cooler lid.
16. Affix custody seals to opposite sides of the cooler lid. Cover the custody seals with clear waterproof tape.
17. Mark the outside of the cooler with the proper shipping name of the contents, corresponding UN number, and LTD. QTY. (as shown below).

**Nitric Acid Solution (with less than 20 percent)**

**UN2031**

**Ltd. Qty.**

## Packaging and Shipping Environmental Samples

SOP 2-1

Revision: 6

Date: February 2015

18. Place a label on the front of the cooler with the company name, contact name, phone number, full street address, and state with zip code for both shipper and recipient.
19. Affix a Corrosive label to the outside of the cooler.
20. Affix package orientation labels on two opposite sides of the cooler.
21. Secure the marking and labels to the surface of the cooler with clear waterproof tape to prevent accidental removal during shipment. An example of cooler labeling/marketing locations is shown in Figure 1.
 

**Note:** Samples meeting the exception concentration of 0.15 percent HNO<sub>3</sub> by weight will be shipped as nonregulated or nonhazardous following the procedure in Section 1.4.

**Note:** No marking or labeling can be obscured by strapping or duct tape.

**Note:** The inner packaging of dangerous goods must be placed into the designated cooler for shipment. Other nonregulated environmental samples may be added to the cooler for shipment.
22. When shipping from a DOE facility, the cooler will be surveyed by a qualified radiation control technician to ensure that radiation flux on exterior surfaces does not exceed 0.5 mrem/h on all sides. This survey will be documented and the results reviewed by the qualified shipper.
23. Complete the Dangerous Goods and Hazardous Materials Inspection Checklist for Shipping Limited-Quantity (Appendix A).
24. Complete a Dangerous Goods Airbill.

## 6.0 Packaging and Shipping Samples Preserved with Sulfuric Acid

### 6.1 Containers

The inner packaging container (and amount of preservative) that may be used for these shipments includes:

Excepted Quantities of Sulfuric Acid Preservatives

| Preservative                   |     | Desired in Final Sample |       | Quantity of Preservative (ml) for Specified Container |        |        |        |     |
|--------------------------------|-----|-------------------------|-------|---|--------|--------|--------|-----|
|                                |     |                         |       | 40 ml   | 125 ml | 250 ml | 500 ml | 1 L |
| H <sub>2</sub> SO <sub>4</sub> | 37N | <1.15                   | 0.35% | .1  | .25    | 0.5    | 1      | 2   |

5 drops = 1 ml

### 6.2 Responsibility

It is the responsibility of the qualified shipper to:

1. Determine the samples undergoing shipment contain no other contaminant that meets the definition of hazardous material as defined by DOT.
2. Determine the amount of preservative in each sample so that accurate determination of quantities can be made.

**Note:** Responsibilities may vary from site to site. Therefore, all field team member responsibilities shall be defined in the field plan or site-/project-specific QAPP.



## Packaging and Shipping Environmental Samples

SOP 2-1

Revision: 6

Date: February 2015

### 6.3 Additional Required Equipment

The following equipment is needed in addition to the required equipment listed in Section 1.3:

- Inner packings may consist of glass or plastic jars no larger than 100 ml.
- Outer packaging (for limited quantities) insulated cooler that has passed the ICAO drop test.
- Survey documentation (if shipping from DOE or radiological sites)
- Class 8 corrosive labels
- Orientation labels
- Consignor/consignee labels

### 6.4 Packaging of Samples Preserved with Sulfuric Acid

Samples containing sulfuric acid ( $H_2SO_4$ ) as a preservative that exceed the expected concentration of 0.35 percent will be shipped as a limited quantity per packing instruction Y809 of the IATA/ICAO Dangerous Goods Regulations.

The following steps are to be followed when packaging limited-quantity samples shipments:

1. Tape any interior opening in the cooler (drain plug) from the inside to ensure control of interior contents. Also, tape the drain plug from the outside of the cooler.
2. All sample containers will be properly labeled and the label protected with waterproof tape before sampling.

At a minimum the label must contain:

- |                                      |   |
|--------------------------------------|---|
| ▪ Project name                       | ▪ Sample identification number  |
| ▪ Project number                     | ▪ Collector's initials  |
| ▪ Date and time of sample collection | ▪ Preservative (note amount of preservative used in miscellaneous section of the chain-of-custody form) |
| ▪ Sample location                    |   |

3. Wrap each glass container in bubble wrap (secure with waterproof tape) to prevent breakage.
4. Place the bubble-wrapped container into a 2.7-mil zip-type bag, removing trapped air.
5. Place glass containers inside a polyethylene bottle filled with an absorbent; seal the bottle.
6. Place sufficient amount of an absorbent in the bottom of the cooler to absorb any leakage that may occur.
7. Place a garbage bag in the cooler.
8. Pack the samples appropriately inside the garbage bag (bottles placed upright) to prevent movement during shipment.
9. Place sufficient amount of double-bagged ice around the samples to maintain the required temperature during shipment.
10. Seal the garbage bag by tying or taping.
11. The maximum volume of preserved solution in the cooler must not exceed 500 ml.
12. The maximum weight of the cooler shall not exceed 30 kg (66 lbs) for any limited-quantity shipment of dangerous goods.
13. Secure the chain-of-custody form (placed inside a zip-type bag) to the interior of the cooler lid.

**Packaging and Shipping Environmental Samples**

SOP 2-1

Revision: 6

Date: February 2015

14. If the shipment is from a DOE or other facility, place the results of the radiation screen and cooler/sample survey with the chain-of-custody.
15. Wrap strapping tape or duct tape around both ends of the cooler and around the cooler lid.
16. Affix custody seals to opposite sides of the cooler lid. Cover the custody seals with clear waterproof tape.
17. Mark the outside of the cooler with the proper shipping name of the contents, corresponding UN number, and LTD. QTY. (as shown below).

**Sulfuric Acid Solution**  
**UN2796**  
**LTD. QTY.**

18. Place a label on the front of the cooler with the company name, contact name, phone number, full street address, and state with zip code for both shipper and recipient.
19. Affix a Corrosive label to the outside of the cooler.
20. Affix package orientation labels on two opposite sides of the cooler.
21. Secure the marking and labels to the surface of the cooler with clear waterproof tape to prevent accidental removal during shipment. An example of cooler labeling/marketing locations is shown in Figure 1.
 

**Note:** Samples containing less than the exception concentration of 0.35 percent H<sub>2</sub>SO<sub>4</sub> by weight will be shipped as nonregulated or nonhazardous in accordance with the procedure described in Section 1.4.

**Note:** No marking or labeling can be obscured by strapping or duct tape.

**Note:** The inner packaging of dangerous goods must be placed into the designated cooler for shipment. Other nonregulated environmental samples may be added to the cooler for shipment.
22. When shipping from a DOE facility, the cooler will be surveyed by a qualified radiation control technician to ensure that radiation flux on exterior surfaces does not exceed 0.5 mrem/h on all sides. This survey will be documented and the results reviewed by the qualified shipper.
23. Complete the Dangerous Goods and Hazardous Materials Inspection Checklist for Shipping Limited-Quantity (Appendix A).
24. Complete a Dangerous Goods Airbill.

**7.0 Packaging and Shipping Limited-Quantity Radioactive Samples****7.1 Containers**

The inner packaging containers that may be used for these shipments include:

1. Any size sample container

## Packaging and Shipping Environmental Samples

SOP 2-1

Revision: 6

Date: February 2015

### 7.2 Description/Responsibilities

The qualified shipper will determine that the samples undergoing shipment contain no other contaminant that meets the definition of hazardous material as defined by DOT.

The qualified shipper will ship all samples that meet the Class 7 definition of radioactive materials and meet the activity requirements specified in Table 4 and 7 of 49 CFR 173.425, as Radioactive Materials in Limited Quantity. The qualified shipper will verify that all packages and their contents meet the requirements of 49 CFR 173.421, *Limited Quantities of Radioactive Materials*.

The packaging used for shipping will meet the general requirements for packaging and packages specified in 49 CFR 173.24 and the general design requirements provided in 173.410. These standards state that a package must be capable of withstanding the effects of any acceleration, vibration, or vibration resonance that may arise under normal condition of transport without any deterioration in the effectiveness of the closing devices on the various receptacles or in the integrity of the package as a whole and without loosening or unintentionally releasing the nuts, bolts, or other securing devices even after repeated use.

If the shipment is from a DOE facility, radiological screenings will be completed on all samples taken. The qualified shipper will review the results of each screening (alpha, beta, and gamma speciation). Samples will not be shipped offsite until the radiological screening has been performed.

The total activity for each package will not exceed the relevant limits listed in Table 4 and 7 of 49 CFR 173.425. The  $A_2$  value of the material will be calculated based on all radionuclides found during previous investigations (if any) in the area from which the samples are derived. The  $A_2$  values to be used will be the most restrictive of all potential radionuclides as listed in 49 CFR 173.435.

The radiation level at any point on the external surface of the package bearing the sample(s) will not exceed 0.005 millisievert per hour (mSv/h) (0.5 mrem/hour). These will be verified by dose and activity monitoring before shipment of the package.

The removable radioactive surface contamination on the external surface of the package will not exceed the limits specified in 49 CFR 173.443(a). CDM Smith will apply the DOE-established free release criteria for removable surface contamination of less than 20 dpm/100  $\text{cm}^2$  (alpha) and 1,000 dpm/100  $\text{cm}^2$  (beta/gamma). It shall be noted that these values are more conservative than the DOT requirements for removable surface contamination.

The qualified shipper will verify that the outside of the inner packaging is marked "Radioactive."

The qualified shipper will verify that the excepted packages prepared for shipment under the provisions of 49 CFR 173.421 have a notice enclosed, or shown on the outside of the package, that reads, "**This package conforms to the conditions and limitations specified in 49 CFR 173.421 for radioactive material, excepted package-limited quantity of material, UN2910.**"

**Note:** Responsibilities may vary from site to site. Therefore, all field team member responsibilities shall be defined in the field plan or site-/project-specific QAPP.

### 7.3 Additional Required Equipment

The following equipment is needed in addition to the required equipment listed in Section 1.3:

- Survey documentation/radiation screening results (if shipping from DOE or radiological sites)
- Orientation labels
- Excepted quantities label
- Consignor/consignee labels

## Packaging and Shipping Environmental Samples

SOP 2-1

Revision: 6

Date: February 2015

### 7.4 Packaging of Limited-Quantity Radioactive Samples

The following steps are to be followed when packaging limited-quantity sample shipments:

1. The cooler is to be surveyed by a qualified radiation control technician to ensure that radiation flux on exterior surfaces does not exceed 0.5 mrem/h on all sides. This survey will be documented and the results reviewed by the qualified shipper.
2. Tape any interior opening in the cooler (drain plug) from the inside to ensure control of interior contents. Also, tape the drain plug from the outside of the cooler.
3. All sample containers will be properly labeled and the label protected with waterproof tape before sampling. At a minimum the label must contain:
  - Project name
  - Project number
  - Date and time of sample collection
  - Sample location
  - Sample identification number
  - Collector's initials
4. This step is optional; wrap each container in bubble wrap (secure with waterproof tape) to prevent breakage.
5. Place sufficient amount of an absorbent, or approved packaging material, in the bottom of the cooler to absorb any leakage that may occur.
6. Place a garbage bag in the cooler.
7. Pack the samples appropriately inside the garbage bag (bottles placed upright) to prevent movement during shipment.
8. If required, place a sufficient amount of double-bagged ice around the samples to maintain the required temperature during shipment.
9. Seal the garbage bag by tying or taping.
10. Place a label marked Radioactive on the outside of the sealed bag.
11. Enclose a notice that includes the name of the consignor or consignee and the following statement: ***"This package conforms to the conditions and limitations specified in 49 CFR 173.421 for radioactive material, excepted package-limited quantity of material, UN2910."***
12. Note that both DOT and IATA apply different limits to the quantity in the inside packing and in the outside packing.
13. The maximum weight of the package shall not exceed 30 kg (66 lbs) for any limited-quantity shipment of dangerous goods.
14. Secure the chain-of-custody form (placed inside a zip-type bag) to the interior of the cooler lid.
15. If the shipment is from a DOE or other facility, place the results of the radiation screen and cooler/sample survey with the chain-of-custody.
16. If a cooler is used, wrap strapping tape or duct tape around both ends of the cooler and around the cooler lid.
17. Affix custody seals to opposite sides of the cooler lid. Cover the custody seals with clear waterproof tape.

## Packaging and Shipping Environmental Samples

18. Place a label on the front of the cooler with the company name, contact name, phone number, full street address, and state with zip code for both shipper and recipient.
19. Affix package orientation labels on two opposite sides of the cooler/package.
20. Affix a completed Excepted Quantities label to the side of the cooler/package.
21. Secure any marking and labels to the surface of the cooler with clear waterproof tape to prevent accidental removal during shipment. An example of the cooler labeling/markings is shown in Figure 2.

**Note:** No marking or labeling can be obscured by strapping or duct tape.

22. Complete the Shipment Quality Assurance Checklist (Appendix B).

**Note:** Except as provided in 49 CFR 173.426, the package will not contain more than 15 grams of  $^{235}\text{U}$ .

**Note:** A declaration of dangerous goods is not required.

**Figure 2**  
Radioactive Material – Limited-Quantity Cooler Marking Example

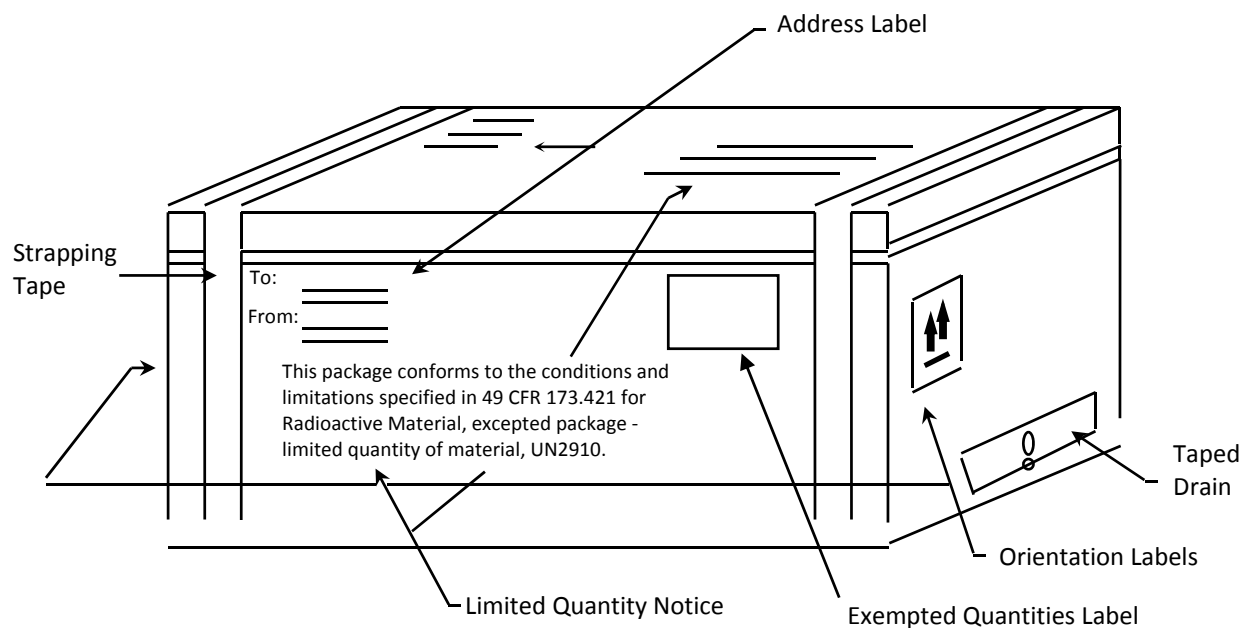

**Packaging and Shipping Environmental Samples**

SOP 2-1  
Revision: 6  
Date: February 2015

**8.0 References**

U. S. Environmental Protection Agency. Region IV. May 2013, or current revision. *Field Branches Quality Management Plan*.

\_\_\_\_\_. August 2011 or current revision. Region IV. *Field Branches Quality Policy*.

\_\_\_\_\_. 2007 or current revision. *Sampler's Guide, Contract Laboratory Program, Guidance for Field Samplers*, EPA-540-R-07-06.

Title 49 Code of Federal Regulations, Department of Transportation. 2015 or current revision. *Hazardous Materials Table, Special Provisions, Hazardous Materials Communications, Emergency Response Information, and Training Requirements*, 49 CFR 172.

Title 49 Code of Federal Regulations, Department of Transportation. 2015 or current revision. *Shippers - General Requirements for Shipments and Packagings*, 49 CFR 173.

## Packaging and Shipping Environmental Samples

SOP 2-1

Revision: 6

Date: February 2015

## Appendix A

**Dangerous Goods and Hazardous Materials Inspection Checklist  
for Shipping Limited-Quantity**

**Sample Packaging**

| Yes | No | N/A |  |
|-----|----|-----|--|
|-----|----|-----|--|

- |                          |                          |                          |  |
|--------------------------|--------------------------|--------------------------|--|
| <input type="checkbox"/> | <input type="checkbox"/> | <input type="checkbox"/> | The VOA vials are wrapped in bubble wrap and placed inside a zip-type bag.                                 |
| <input type="checkbox"/> | <input type="checkbox"/> | <input type="checkbox"/> | The VOA vials are placed into a polyethylene bottle, filled with an absorbent, and tightly sealed.         |
| <input type="checkbox"/> | <input type="checkbox"/> | <input type="checkbox"/> | The drain plug is taped inside and outside to ensure control of interior contents.                         |
| <input type="checkbox"/> | <input type="checkbox"/> | <input type="checkbox"/> | The samples have been placed inside garbage bags with sufficient bags of ice to preserve samples at 4°C.   |
| <input type="checkbox"/> | <input type="checkbox"/> | <input type="checkbox"/> | The cooler weighs less than the 66-pound limit for limited-quantity shipment.                              |
| <input type="checkbox"/> | <input type="checkbox"/> | <input type="checkbox"/> | The garbage bag has been sealed with tape (or tied) to prevent movement during shipment.                   |
| <input type="checkbox"/> | <input type="checkbox"/> | <input type="checkbox"/> | The chain-of-custody has been secured to the interior of the cooler lid.                                   |
| <input type="checkbox"/> | <input type="checkbox"/> | <input type="checkbox"/> | The cooler lid and sides have been taped to ensure a seal.   |
| <input type="checkbox"/> | <input type="checkbox"/> | <input type="checkbox"/> | The custody seals have been placed on both the front and back hinges of the cooler, using waterproof tape. |

**Air Waybill Completion**

| Yes | No | N/A |  |
|-----|----|-----|--|
|-----|----|-----|--|

- |                          |                          |                          |  |
|--------------------------|--------------------------|--------------------------|--|
| <input type="checkbox"/> | <input type="checkbox"/> | <input type="checkbox"/> | Section 1 has the shipper's name, company, and address; the account number, date, internal billing reference number; and the telephone number where the shipper can be reached.  |
| <input type="checkbox"/> | <input type="checkbox"/> | <input type="checkbox"/> | Section 2 has the recipient's name and company along with a telephone number where they can be reached.  |
| <input type="checkbox"/> | <input type="checkbox"/> | <input type="checkbox"/> | Section 3 has the <b>Bill Sender</b> box checked.  |
| <input type="checkbox"/> | <input type="checkbox"/> | <input type="checkbox"/> | Section 4 has the <b>Standard Overnight</b> box checked.   |
| <input type="checkbox"/> | <input type="checkbox"/> | <input type="checkbox"/> | Section 5 has the <b>Deliver Weekday</b> box checked.  |
| <input type="checkbox"/> | <input type="checkbox"/> | <input type="checkbox"/> | Section 6 has the number of packages and their weights filled out. Was the total of all packages and their weights figured up and added at the bottom of Section 6?  |
| <input type="checkbox"/> | <input type="checkbox"/> | <input type="checkbox"/> | Under the <b>Transport Details</b> box, the <b>Cargo Aircraft Only</b> box is obliterated, leaving only the <b>Passenger and Cargo Aircraft</b> box.   |
| <input type="checkbox"/> | <input type="checkbox"/> | <input type="checkbox"/> | Under the <b>Shipment Type</b> , the <b>Radioactive</b> box is obliterated, leaving only the <b>Non-Radioactive</b> box.   |
| <input type="checkbox"/> | <input type="checkbox"/> | <input type="checkbox"/> | Under the <b>Nature and Quantity of Dangerous Goods</b> box, the <b>Proper Shipping Name, Class or Division, UN or ID No., Packing Group, Subsidiary Risk, Quantity and Type of Packing, Packing Instructions, and Authorization</b> have been filled out for the type of chemical being sent. |
| <input type="checkbox"/> | <input type="checkbox"/> | <input type="checkbox"/> | The <b>Name, Place and Date, Signature, and Emergency Telephone Number</b> appears at the bottom of the FedEx Airbill.   |
| <input type="checkbox"/> | <input type="checkbox"/> | <input type="checkbox"/> | The statement "In accordance with IATA/ICAO" appears in the <b>Additional Handling Information</b> box.  |
| <input type="checkbox"/> | <input type="checkbox"/> | <input type="checkbox"/> | The <b>Emergency Contact Information</b> at the bottom of the FedEx Airbill is truly someone who can respond any time of the day or night.   |

## Packaging and Shipping Environmental Samples

SOP 2-1

Revision: 6

Date: February 2015

| <i>Proper Shipping Name</i>               | <i>Class or Division</i> | <i>UN or ID No.</i> | <i>Packing Group</i> | <i>Sub Risk</i> | <i>Quantity</i>       | <i>Packing Instruction</i> | <i>Authorization</i> |
|---|--------------------------|---------------------|----------------------|-----------------|-----------------------|----------------------------|----------------------|
| Hydrochloric Acid Solution                | 8                        | UN1789              | II                   |                 | 1 plastic box × 0.5 L | Y809                       | Ltd. Qty.            |
| Nitric Acid Solution (with less than 20%) | 8                        | UN2031              | II                   |                 | 1 plastic box × 0.5 L | Y807                       | Ltd. Qty.            |
| Sodium Hydroxide Solution                 | 8                        | UN1824              | II                   |                 | 1 plastic box × 0.5 L | Y809                       | Ltd. Qty.            |
| Sulfuric Acid Solution                    | 8                        | UN2796              | II                   |                 | 1 plastic box × 0.5 L | Y809                       | Ltd. Qty.            |
| Methanol                                  | 3                        | UN1230              | II                   |                 | 1 plastic box × 1 L   | Y305                       | Ltd. Qty.            |

**Sample Cooler Labeling**

| Yes | No | N/A |  |
|-----|----|-----|--|
|-----|----|-----|--|

- |                          |                          |                          |   |
|--------------------------|--------------------------|--------------------------|---|
| <input type="checkbox"/> | <input type="checkbox"/> | <input type="checkbox"/> | The proper shipping name, UN number, and Ltd. Qty. appears on the shipping container.                       |
| <input type="checkbox"/> | <input type="checkbox"/> | <input type="checkbox"/> | The corresponding hazard labels are affixed on the shipping container; the labels are not obscured by tape. |
| <input type="checkbox"/> | <input type="checkbox"/> | <input type="checkbox"/> | The name and address of the shipper and receiver appear on the top and side of the shipping container.      |
| <input type="checkbox"/> | <input type="checkbox"/> | <input type="checkbox"/> | The air waybill is attached to the top of the shipping container.   |
| <input type="checkbox"/> | <input type="checkbox"/> | <input type="checkbox"/> | <b>Up Arrows</b> have been attached to opposite sides of the shipping container.                            |
| <input type="checkbox"/> | <input type="checkbox"/> | <input type="checkbox"/> | Packaging tape does not obscure markings or labeling.   |



**Packaging and Shipping Environmental Samples**

SOP 2-1  
Revision: 6  
Date: February 2015

**Appendix B**

**Shipment Quality Assurance Checklist**

Date: \_\_\_\_\_ Shipper: \_\_\_\_\_ Destination: \_\_\_\_\_

Item(s) Description: \_\_\_\_\_

Radionuclide(s): \_\_\_\_\_

Radiological Survey Results: surface \_\_\_\_\_ mrem/hr      1 meter \_\_\_\_\_

Instrument Used: Mfgr: \_\_\_\_\_ Model: \_\_\_\_\_

S/N: \_\_\_\_\_ Cal Date: \_\_\_\_\_

**Limited-Quantity or Instrument and Article**

- | Yes | No  |   |
|-----|-----|---|
| ___ | ___ | 1. Strong tight package (package that will not leak material during conditions normally incidental to transportation).  |
| ___ | ___ | 2. Radiation levels at any point on the external surface of package less than or equal to 0.5 mrem/hr.  |
| ___ | ___ | 3. Removable surface contamination less than 20 dpm/100 cm <sup>2</sup> (alpha) and 1,000 dpm/100 cm <sup>2</sup> (beta/gamma).   |
| ___ | ___ | 4. Outside inner package bears the marking "Radioactive."   |
| ___ | ___ | 5. Package contains less than 15 grams of <sup>235</sup> U (check yes if <sup>235</sup> U not present).   |
| ___ | ___ | 6. Notice enclosed in or on the package that includes the consignor or consignee and the statement, <b>"This package conforms to the conditions and limitations specified in 49 CFR 173.421 for radioactive material, excepted package-limited quantity of material, UN2910."</b> |
| ___ | ___ | 7. Activity less than that specified in 49 CFR 173.425. Permissible package limit:<br>Package Quantity:   |
| ___ | ___ | 8. On all air shipments, the statement <b>Radioactive Material, excepted package-limited quantity of material</b> shall be noted on the air waybill.  |

Qualified Shipper: \_\_\_\_\_ Signature: \_\_\_\_\_

## Guide to Handling Investigation-Derived Waste

SOP 2-2

Revision: 8

Date: February 2015

Approved:

  
Signature

Technical Review:

Dave Sembrot

### 1.0 Objective

This technical standard operating procedure (SOP) presents guidance for the management of investigation-derived waste (IDW). The primary objectives for managing IDW during field activities include:

- Leaving the site in no worse condition than existed before field activities
- Removing wastes that pose an immediate threat to human health or the environment
- Proper handling of onsite wastes that do not require offsite disposal or extended aboveground containerization
- Complying with federal, state, local, and facility applicable or relevant and appropriate requirements (ARARs)
- Careful planning and coordination of IDW management options
- Minimizing the quantity of IDW

### 2.0 Background

#### 2.1 Definitions

**Hazardous Waste** - Discarded material that is regulated listed waste, or waste that exhibits ignitability, corrosivity, reactivity, or toxicity as defined in 40 CFR 261.3 or state regulations.

**Investigation-Derived Wastes** - Discarded materials resulting from field activities such as sampling, surveying, drilling, excavation, and decontamination processes that, in present form, possess no inherent value or additional usefulness without treatment. Wastes may be solid, sludge, liquid, gaseous, or multiphase materials that may be classified as hazardous or nonhazardous.

**Mixed Waste** - Any material that has been classified as both hazardous and radioactive.

**Radioactive Wastes** - Discarded materials that are contaminated with radioactive constituents with specific activities in concentrations greater than the latest regulatory criteria (i.e., 10 CFR 20).

**Treatment, Storage, and Disposal Facility (TSDF)** - Permitted facilities that accept hazardous waste shipments for further treatment, storage, and/or disposal. These facilities must be permitted by the U. S. Environmental Protection Agency (EPA) and appropriate state and local agencies.

Aqueous liquid – a water based polar solution with a specific gravity at or near 1. Light non-aqueous phase liquids, also known as (a.k.a) LNAPL (non-polar), such as oils, typically float on aqueous (polar) solutions (or pure water). Dense non-aqueous phase liquids (a.k.a. DNAPL), such as chlorinated organic solvents or PCB containing oils, sink in aqueous based liquids.

#### 2.2 Discussion

Field investigation activities result in the generation of waste materials that may be characterized as hazardous or radioactive. IDWs may include drilling muds, cuttings, and purge water from test pit and well installation; purge water, soil, and other materials from collection of samples; residues from testing of treatment technologies and pump and treat systems; personal protective equipment (PPE); solutions (aqueous or otherwise) used to decontaminate nondisposable protective clothing and equipment; and other wastes or supplies used in sampling and testing potentially hazardous or radiologically contaminated material.

**Note:** The client's representatives may not be aware of all potential contaminants. The management of IDW must comply with applicable regulatory requirements.

## Guide to Handling Investigation-Derived Waste

SOP 2-2

Revision: 8

Date: February 2015

### 3.0 General Responsibilities

**Site Manager** - The site manager is responsible for ensuring that all IDW procedures are conducted in accordance with this SOP. The site manager is also responsible for ensuring that handling of IDW is in accordance with site-specific requirements.

**Project Manager** - The project manager is responsible for identifying site-specific requirements for the disposal of IDW in accordance with federal, state, and/or facility requirements.

**Field Crew Members** - Field crew members are responsible for implementing this SOP and communicating any unusual or unplanned condition to the project manager's attention.

**Note:** Responsibilities may vary from site to site. Therefore, all field team member responsibilities shall be defined in the field plan or site/project specific quality assurance plan.

### 4.0 Required Equipment

Equipment required for IDW containment will vary according to site-specific/client requirements. Management decisions concerning the necessary equipment required shall consider: containment method, sampling, labeling, maneuvering, and storage (if applicable). Equipment must be onsite and inspected before commencing work.

The selection of the container type and size for containerizing IDW must consider:

- waste/contaminant segregation (i.e. do not mix hazardous and non-hazardous wastes or incompatible materials),
- efficiency/ability to move the containerized waste (i.e. size of equipment needed vs. accessibility and bulk vs. individual containers),
- cost of storage, (i.e. rental vs. purchase)
- transportation and disposal of the material in the containers selected.

#### 4.1 IDW Containment Devices

The appropriate containment device (drums, tanks, etc.) will depend on site- or client-specific requirements and the ultimate disposition of the IDW. Typical IDW containment devices can include:

- Plastic sheeting (polyethylene) with a minimum thickness of 20 micrometers
- Department of Transportation (DOT)-approved steel containers
- Polyethylene or steel bulk storage tanks

Containment of IDW shall be segregated by waste type (i.e., solid or liquid, corrosive or flammable, etc.) and source location. Volume of the appropriate containment device will depend on site-specific requirements.

#### 4.2 IDW Container Labeling

A "Waste Container" or "IDW Container" label or indelible marking shall be applied to each container. Labeling or marking requirements for onsite IDW not expected to be transported offsite are as detailed below.

- Labels and markings must contain the following information: project name, generation date, location of waste origin, container identification number, sample number (if applicable), and contents (drill cuttings, purge water, PPE, etc.).
- Each label or marking will be applied to the upper one-third of the container at least twice, on opposite sides.
- Containers that are 5 gallons or less may only require one label or set of markings.
- Labels or markings will be positioned on a smooth part of the container. The label must not be affixed across container bungs, seams, ridges, or dents.
- Labels must be constructed of a weather-resistive material with markings made with a permanent marker or paint pen and capable of enduring the expected weather conditions. If markings are used, the color must be easily distinguishable from the container color.
- Labels will be secured in a manner to ensure that they remain affixed to the container.

## Guide to Handling Investigation-Derived Waste

SOP 2-2

Revision: 8

Date: February 2015

Labeling or marking requirements for IDW expected to be transported offsite must be in accordance with the requirements of 49 CFR 172.

### 4.3 IDW Container Movement

Staging areas for IDW containers shall be predetermined and in accordance with site-specific and/or client requirements. Arrangements shall be made before field mobilization as to the methods and personnel required to safely transport IDW containers to the staging area. Transportation of IDW containers offsite via a public roadway is prohibited unless 49 CFR 172 requirements are met.

### 4.4 IDW Container Storage

Containerized IDW awaiting results of pending chemical analysis or further onsite treatment shall be staged on site. Staging areas and bulk storage procedures are to be determined according to site-specific requirements. Containers are to be stored in such a fashion that the labels can be easily read. A secondary/spill container must be provided for liquid IDW storage and as appropriate for solid IDW storage (e.g., steel drums shall not be stored in direct contact with the ground).

## 5.0 Procedures

The three general options for managing IDW are: (1) collection and onsite disposal, (2) collection for offsite disposal, and (3) collection and interim management. Attachment 1 summarizes media-specific information on generation processes and management options. The option selected shall take into account the following factors:

- Type (soil, sludge, liquid, debris), quantity, and source of IDW
- Risk posed by managing the IDW onsite
- Compliance with regulatory requirements
- IDW minimization and consistency with the IDW remedy and the site remedy

In all cases the client shall approve the plans for IDW. Formal plans for the management of IDW must be prepared as part of a work plan or separate document.

### 5.1 Collection and Onsite Disposal

#### 5.1.1 Soil/Sludge/Sediment

The options for handling soil/sludge/sediment IDW are:

1. Return IDW to boring, pit, or source immediately after generation as long as returning the media to these areas will not increase site risks (e.g., so that "clean" areas are not contaminated, the IDW material will not be replaced at a greater depth, or in a different area than from where it was originally obtained).
2. Spread IDW around boring, pit, or source within the area of contamination (AOC) as long as returning the media to these areas will not increase site risks (e.g., direct contact with surficial contamination).
3. Consolidate IDW in a pit within the AOC as long as returning the media to these areas will not increase site risks (e.g., the contaminated soil will not be replaced at a greater depth than where it was originally so that it will not contaminate "clean" areas).
4. Send to onsite TSDF. This option may require results of laboratory analysis before treatment/disposal.

**Note:** These options may require client and/or regulatory approval.

#### 5.1.2 Aqueous Liquids

The options for handling aqueous liquid IDW are:

## Guide to Handling Investigation-Derived Waste

SOP 2-2

Revision: 8

Date: February 2015

1. Discharge to surface water, only when IDW is not contaminated, and with written client approval.
2. Discharge to ground surface close to the well from which it was extracted, only if soil contaminants will not be mobilized in the process and the action will not contaminate clean areas. If IDW from the sampling of background upgradient wells is not a community concern or associated with soil contamination, this presumably uncontaminated IDW may be released on the ground around the well with written client approval.
3. Discharge to sanitary sewer, only when IDW is not contaminated and with written client approval.
4. Send to onsite treatment/disposal facility, with facility acceptance and written client approval.

**Note:** These options may require results of laboratory analysis to obtain client and/or regulatory approval.

5. When small amounts (i.e., less than 5 gallons) of used decontamination fluids are generated during site characterization activities (e.g., during soil sampling using direct push technology methods), the fluids may be allowed to evaporate by spreading them on an asphalted surface, or allowing for evaporation from an open bucket.

### 5.1.3 Disposable PPE

The options for handling disposable PPE are:

1. Double-bag contents in nontransparent trash bags and place in onsite industrial dumpster, only if PPE is not contaminated.
2. Containerize, label, and send to onsite TSDF. This may require results of laboratory analysis before treatment/disposal.

## 5.2 Collection for Offsite Disposal

Before sending IDW to an offsite TSDF or to a publicly owned treatment works (POTW), laboratory analysis may be required. Manifests are required to accompany any IDW determined to be hazardous. In some instances, a bill of lading can be used for nonhazardous solid IDW (i.e., wooden pallets, large quantities of plastic sheeting). Arrangements must be made with the client responsible for the site to sign as generator on any waste profile and all manifests or bill of ladings; it is CDM Smith's policy not to sign any waste profile or manifest. The TSDF and transporter must be permitted for the respective wastes. Nonbulk containers (e.g., drums) must have a DOT-approved label adhered to the container and all required associated placard stickers before leaving for an offsite TSDF. These labels must include information as required in 49 CFR 172. Bulk containers (i.e., rolloffs, tanks) do not require container specific labels for transporting offsite, but must include appropriate placards as required in 49 CFR 172.

### 5.2.1 Soil/Sludge/Sediment

When the final site remedy requires offsite treatment and disposal, the IDW may be stored (e.g., drummed, covered in a waste pile) or returned to its source until final disposal. The management option selected shall take into account the potential for increased risks, applicable regulations, and other relevant site-specific factors (e.g., weather, storage space, and public concern/perceptions).

### 5.2.2 Aqueous Liquids

When the final site remedy requires offsite treatment and disposal, the IDW may be stored (e.g., mobile tanks or drums with appropriate secondary containment) until final disposal. The management option selected shall take into account the potential for increased risks, applicable regulations, and other relevant site-specific factors (e.g., weather, storage space, and public concern/perceptions).

### 5.2.3 Disposable PPE

When the final site remedy requires offsite treatment and disposal, the IDW may be containerized and stored. The management option selected shall take into account potential for increased risks, applicable regulations, and other relevant site-specific factors (e.g., weather, storage space, and public concern/perceptions).

## Guide to Handling Investigation-Derived Waste

SOP 2-2

Revision: 8

Date: February 2015

### 5.3 Collection and Interim Management

All interim measures must be approved by the client and regulatory agencies.

1. Storing IDW onsite until the final action may be practical in the following situations:
  - Returning wastes (especially sludges and soils) to their onsite source area would require reexcavation for disposal as determined for the final site remedy.
  - Interim storage in containers may be necessary to provide adequate protection to human health and the environment.
  - Offsite disposal options may trigger land disposal regulations under the Resource Conservation and Recovery Act (RCRA). Storing IDW until the final disposal of all wastes from the site will eliminate the need to address this issue more than once.
  - Interim storage may be necessary to provide time for sampling and analysis.
2. Segregate and containerize all waste for future treatment and/or disposal.
  - Containment options for soil/sludge/sediment may include drums or covered waste piles in AOC.
  - Containment options for aqueous liquids may include mobile tanks or drums.
  - Containment options for PPE may include drums or roll-off boxes.

### 6.0 Restrictions/Limitations

Site managers shall determine the most appropriate disposal option for aqueous liquids on a site-specific basis. Parameters to consider, especially when determining the level of protection, include the volume of IDW, the contaminants present in the aqueous liquid, the nature of contaminants present in the site soil, and whether groundwater or surface water is a drinking water supply, and if obtained from contaminated groundwater, whether the plume is contained or migrating. Special disposal/handling may be needed for drilling fluids because they may contain significant solid components and therefore may need to be handled, treated, disposed as non-liquid wastes.

Disposable sampling materials, disposable PPE, decontamination fluids, etc. will always be managed on a site-specific basis. Under no circumstances shall these types of materials be stored in a site office or warehouse.

### 7.0 References

Environmental Resource Center. 1997. *Hazardous Waste Management Compliance Handbook 2nd Edition*. Karnofsky (Editor).

Academy of Certified Hazardous Materials Manager. May 1999. *Hazardous Materials Management Desk Reference*. Cox.

Title 49 Code of Federal Regulations, Department of Transportation. 2005 or current revision. *Hazardous Materials Table, Special Provisions, Hazardous, Materials Communications, Emergency Response Information, and Training Requirements*, 49 CFR 172.

U. S. Environmental Protection Agency. 1987. *A Compendium of Superfund Field Operations Methods*, EPA/540/P-87/001.1.

\_\_\_\_\_. August 1990. *Low-Level Mixed Waste: A RCRA Perspective for NRC Licensees*, EPA/530-SW-90-057.

\_\_\_\_\_. May 1991. *Management of Investigation-Derived Wastes During Site Inspections*, EPA/540/G-91/009.

\_\_\_\_\_. January 1992. *Guide to Management of Investigation-Derived Wastes*, 9345.3-03FS.

\_\_\_\_\_. Region IV. November 2001. *Environmental Investigations Standard Operating Procedures and Quality Assurance Manual*.

## Guide to Handling Investigation-Derived Waste

SOP 2-2

Revision: 8

Date: February 2015

### Attachment 1 IDW Management Options

| <i>Type of IDW</i>   | <i>Generation Processes</i>   | <i>Management Options</i>  |
|--|---|--|
| Soil   | <ul style="list-style-type: none"> <li>▪ Well/Test pit installations</li> <li>▪ Borehole drilling</li> <li>▪ Soil sampling</li> </ul>   | <p><b>Onsite Disposal</b></p> <ul style="list-style-type: none"> <li>▪ Return to boring, pit, or source immediately after generation</li> <li>▪ Spread around boring, pit, or source within the AOC</li> <li>▪ Consolidate in a pit (within the AOC)</li> <li>▪ Send to onsite TSDF</li> </ul> <p><b>Offsite Disposal</b></p> <ul style="list-style-type: none"> <li>▪ Client to send to offsite TSDF</li> </ul> <p><b>Interim Management</b></p> <ul style="list-style-type: none"> <li>▪ Store for future treatment and/or disposal</li> </ul> |
| Sludge/Sediment  | <ul style="list-style-type: none"> <li>▪ Sludge pit/sediment sampling</li> </ul>  | <p><b>Onsite Disposal</b></p> <ul style="list-style-type: none"> <li>▪ Return to pit or source immediately after generation</li> <li>▪ Send to onsite TSDF</li> </ul> <p><b>Offsite Disposal</b></p> <ul style="list-style-type: none"> <li>▪ Send to offsite TSDF*</li> </ul> <p><b>Interim Management</b></p> <ul style="list-style-type: none"> <li>▪ Store for future treatment and/or disposal</li> </ul>   |
| Aqueous Liquids<br>(groundwater, surface water, drilling fluids, wastewater) | <ul style="list-style-type: none"> <li>▪ Well installation/development</li> <li>▪ Well purging during sampling</li> <li>▪ Groundwater discharge during pump tests</li> <li>▪ Surface water sampling</li> <li>▪ Wastewater sampling</li> </ul> | <p><b>Onsite Disposal</b></p> <ul style="list-style-type: none"> <li>▪ Pour onto ground close to well (nonhazardous waste)</li> <li>▪ Discharge to sewer</li> <li>▪ Send to onsite TSDF</li> </ul> <p><b>Offsite Disposal</b></p> <ul style="list-style-type: none"> <li>▪ Send to offsite TSDF*</li> <li>▪ Client to send to publicly owned treatment works (POTW)</li> </ul> <p><b>Interim Management</b></p> <ul style="list-style-type: none"> <li>▪ Store for future treatment and/or disposal</li> </ul>                                   |
| Decontamination Fluids   | <ul style="list-style-type: none"> <li>▪ Decontamination of PPE and equipment</li> </ul>  | <p><b>Onsite Disposal</b></p> <ul style="list-style-type: none"> <li>▪ Send to onsite TSDF</li> <li>▪ Evaporate (for small amounts of low contamination organic fluids)</li> <li>▪ Discharge to ground surface</li> </ul> <p><b>Offsite Disposal</b></p> <ul style="list-style-type: none"> <li>▪ Send to offsite TSDF*</li> <li>▪ Discharge to sewer</li> </ul> <p><b>Interim Management</b></p> <ul style="list-style-type: none"> <li>▪ Store for future treatment and/or disposal</li> </ul>   |
| Disposable PPE and Sampling Equipment  | <ul style="list-style-type: none"> <li>▪ Sampling procedures or other onsite activities</li> </ul>  | <p><b>Onsite Disposal</b></p> <ul style="list-style-type: none"> <li>▪ Place in onsite industrial dumpster</li> <li>▪ Send to onsite TSDF</li> </ul> <p><b>Offsite Disposal</b></p> <ul style="list-style-type: none"> <li>▪ Send to offsite TSDF*</li> </ul> <p><b>Interim Management</b></p> <ul style="list-style-type: none"> <li>▪ Store for future treatment and/or disposal</li> </ul>  |

\* Client must sign waste profile, manifest, etc. for any waste sent offsite.

Adapted from U. S. Environmental Protection Agency, *Guide to Management of Investigation-Derived Wastes*, 9345-03FS, January 1992.

**Geoprobe® Sampling**

SOP 3-1

Revision: 7

Date: February 2015

Approved:

  
Signature

Technical Review:

Stuart Barden

**1.0 Objective**

The objective of this technical standard operating procedure (SOP) is to define the requirements for collecting soil, soil gas, groundwater, and pneumatic slug test data using the Geoprobe® sampling system. Geoprobe is a trade name proprietary to Geoprobe Systems of Salina, Kansas.

**2.0 Background****2.1 Definitions**

**Geoprobe** - A hydraulically-operated hammer device installed on the back of a van, pickup truck, or tracked vehicle used to advance a hollow-stem rod into the soil for the purpose of collecting soil, soil gas, or groundwater samples.

**Probe-Drive Sampler** - A sampling device, similar to a split-spoon sampler, used to collect soil samples with a Geoprobe rig. Two primary types of soil samplers are available: Dual Tube (DT), and Macro-Core® (MC) sampler (with a PVC liner). Sample core lengths range from 24 to 72-inches and diameters range from 1.125 to 4-inches. Search Geoprobe Systems website for probe rods and DT and MC samplers for additional specific sizes available.

**Extension Rod** - Stainless steel rod used to remove stop-pin and drive-point assembly.

**Extension Rod Coupler** - Stainless steel connector used to join sections of extension rods.

**Drive Point** - Solid steel retractable point used to advance sample collection device to the required sample depth.

**Probe Rod** - Hollow, flush-threaded, steel rod similar to a drill rod.

**Stop-Pin** - Steel plug that threads into the top of the drive cap to hold the drive point in place during advancement of the probe rods.

**Drive Cap** - Threaded, hardened-steel top cap that attaches to the top of the probe rod; used when advancing the probe rods with the hydraulic hammer.

**Pull Cap** - Threaded, hardened-steel top cap that attaches to the top of the probe rod; used when retracting the probe rods.

**Extruder Rack and Piston** - A device used in conjunction with the Geoprobe to force soil sample volume out of the sample tube.

**Screen Point Groundwater Sampler** - A groundwater sampling device designed for use with the Geoprobe consisting of a well screen encased in a perforated stainless steel sleeve.

**Mill-Slotted Well Rod and Point** - A groundwater sampling device designed for use with the Geoprobe consisting of a Geoprobe probe rod with 15-mil slots, each 5 cm long by 0.05 cm wide (2 inches long x 0.020 inches wide).

**Post-Run Tubing System (PRT)** - The Geoprobe soil vapor sampling system uses disposable polyethylene or Teflon tubing (inserted into the probe rods at the desired sampling depth) and a vacuum.

**Expendable Drive Point** - Solid steel point attached to the end of the screen point groundwater sampler and PRT expendable point holder.



**Geoprobe® Sampling**

SOP 3-1

Revision: 7

Date: February 2015

**Membrane Interface Probe (MIP)** - A screening tool with semi-quantitative capabilities acting as an interface between the volatile contaminants in the subsurface and gas phase detectors at the surface. The membrane is placed in a heated block attached to the probe. Heating the block accelerates diffusion of the contaminant through the membrane into the carrier gas, which flows up hole to the detectors.

**2.2 Associated Procedures**

- SOP 1-2, *Sample Custody*
- SOP 2-1, *Packaging and Shipping Environmental Samples*
- SOP 1-5, *Groundwater Sampling Using a Bailer*
- SOP 1-6, *Water Level Measurements*
- SOP 2-1, *Packaging and Shipping Environmental Samples*
- SOP 4-1, *Field Logbook Content and Control*
- SOP 4-3, *Well Development and Purging*
- SOP 4-5, *Field Equipment Decontamination*

**2.3 Discussion**

The Geoprobe unit consists of a hydraulically-operated hammer device that can be mounted on the back of a van, a pickup truck or track-mounted (Figure 1). The Geoprobe system hydraulically advances small-diameter, hollow rods to the desired sampling depth. The specific type of Geoprobe sampling equipment for soil, soil gas, and groundwater collection is then employed.

The use of Geoprobe technology may be a cost-effective alternative to using conventional drilling techniques for collecting subsurface soil, soil gas, and groundwater samples depending on the site-specific geologic and hydrogeologic conditions and sample requirements. The Geoprobe system is generally used to gather screening-level data. The site-specific sampling plans must consider such factors as soil types, presence of cobbles, depth to groundwater, quantity and depth of samples, site access and topography, data quality objectives (DQOs), analytical requirements, and waste handling and disposal requirements before selecting the use of the Geoprobe.

Advantages of using the Geoprobe Systems include:

- Areas usually considered inaccessible by drill rigs because of overhead wires, steep slopes, size constraints, etc., may be accessed with a van-, pickup truck-, or track-mounted Geoprobe.
- Investigation-derived wastes such as soil cuttings and purge water are minimized with the Geoprobe due to its small diameter rods and its displacement of soil horizontally, not vertically.
- Pneumatic slug testing is also an option when using the SP16 groundwater sampler. Analyses of these tests will yield hydraulic conductivity values for the surrounding aquifer materials.

A Geoprobe membrane interface probe (MIP) and integrated electrical conductivity (EC) dipole combination can be deployed with direct push methods to discriminate variation in grain size and volatile organic contaminants (VOCs). As a result, lithologic changes and distribution of contaminants (chlorinated and nonchlorinated) can be determined in the subsurface.

Cost savings over conventional drilling techniques may be realized. The Geoprobe is rented/leased on a daily, weekly, or monthly basis for a fixed price as opposed to drilling subcontractors who are generally compensated based on the footage drilled. For shallow probing, the Geoprobe may be hand-operated by field personnel rather than subcontractors. A cost evaluation based on project-specific requirements and site conditions shall be conducted to determine the most cost-effective method for a particular project.

**Geoprobe® Sampling**

SOP 3-1

Revision: 7

Date: February 2015

Two people are required to operate the Geoprobe and conduct sampling and recordkeeping activities. Safety considerations shall be addressed when operating the Geoprobe. A safety hazard is present whenever the Geoprobe is operated. The hydraulic system operates with a fluid pressure of over 2,000 pounds per square inch (psi). A leaking hose may produce a stream of hydraulic fluid with sufficient pressure to penetrate skin. Therefore, periodic checks of the hydraulic lines and hoses shall be conducted to ensure they are in good condition and connections are tight. Do not attempt to repair or tighten hoses with the engine running and the system under pressure. Use paper or cardboard to check for leaks.

**3.0 General Responsibilities**

**Field Team Leader (FTL)** - The field team leader (FTL) is responsible for ensuring that sampling efforts are conducted in accordance with this procedure, associated SOPs, and the site-specific plans.

**Sampling Personnel** - Field team members are responsible for conducting Geoprobe sampling events in accordance with this procedure, all associated SOPs, and requirements as described in the site-specific plans.

**Note:** Responsibilities may vary from site to site. Therefore, all field team member responsibilities shall be defined in the field plan or site/quality assurance project plan (QAPP).

**4.0 Required Equipment****General**

- Site-specific plans
- Field logbook, chain-of-custody forms, other forms for documenting sample shipment
- Indelible black or blue ink pens and markers
- Sample containers with labels and preservatives
- Insulated coolers
- Bagged ice or "blue ice"
- Plastic zip-top bags
- Waterproof sealing tape
- Temperature, conductivity, pH, dissolved oxygen, and turbidity meters (with clean beakers or other appropriate containers), as required by the site-specific plans
- Monitoring/screening instruments as required by the site-specific health and safety plan or sampling plan
- Decontamination supplies, as required by SOP 4-5
- Personal protective equipment (PPE), as required by the site-specific health and safety plan (at a minimum, hard hat, steel-toed shoes, safety glasses, and hearing protection are required)
- Latex or appropriate gloves
- Geoprobe rig (van, truck, or track-mounted) with the following:
  - Probe rods (1 to 5-foot [ft]) lengths
  - Extension rods (1 to 5-ft) lengths, couplers, and handle
  - Piston stop-pins (two each per rig, minimum)
  - Drive caps and pull caps (two each per rig, minimum)
  - Carbide-tipped drill bit for working in concrete- or asphalt-covered areas
  - O-rings

**Geoprobe Soil Sampling Equipment**

- Extruder rack and piston (i.e., if soil is to be extruded into a sample container)
- Assembled DT or MC soil samplers (The stainless steel sample tubes or PVC liners from these samplers may be individually sealed and shipped directly to the laboratory, as indicated in site-specific plans)
- Refer to the Geoprobe Systems website for specific parts and accessories for each sampler

**Geoprobe® Sampling**

SOP 3-1

Revision: 7

Date: February 2015

**Geoprobe Soil Gas Sampling Equipment**

- Expendable drive points (one each per sample location, plus spares)
- Extension rod ram
- 10 millimeter (mm) (3/8-inch) polyethylene (Teflon-lined) tubing and PRT adapter
- Vacuum or sampling system
- Syringe
- PRT adapter
- PRT expendable point holder

**Geoprobe Groundwater Sampling Equipment**

- Expendable drive points (one each per sample location, plus spares)
- Mill-slotted well point or screen point groundwater sampler assemblies
- Extension rod ram
- 10-mm (3/8-inch) polyethylene or Teflon-lined tubing
- Check valves (if using Waterra system)
- Peristaltic pump (limited to shallow depths)
- Mini-bailer (with thin nylon line)

**5.0 Procedures**

Procedures common to all three sampling methods are discussed below.

**Before sampling:**

- Review site-specific health and safety plan and project plans before initiating sampling activity.
- Arrange utility clearance.
- Decontaminate all Geoprobe equipment according to SOP 4-5, *Field Equipment Decontamination*.
- Don the appropriate PPE as dictated by the site-specific health and safety plan.
- If the sampling site is in a concrete- or asphalt-covered area, drill a hole using the rotary function and a specially designed carbide-tipped drill bit of the diameter appropriate for the selected sampler diameter. Otherwise, the area needs to be cleared of heavy underbrush and immediate overhead obstructions.

**After sampling is completed:**

- Thread the pull cap onto the top probe rod and retract the probe rods.
- Seal the borehole with sand, neat cement, or bentonite grout, if necessary.
- Record all appropriate data in the field logbook and on the chain-of-custody forms as outlined in SOP 4-1, *Field Logbook Content and Control* and SOP 2-1, *Packaging and Shipping Environmental Samples*.
- Decontaminate the sampling equipment according to SOP 4-5, *Field Equipment Decontamination*.

**5.1 Soil Sampling****Assembly**

1. Assemble the sampling device as follows:

- Screw the cutting shoe to the bottom end of the sample tube, unless using standard probe drive sampler which has a built-in cutting edge.
- Screw the piston tip onto the piston rod.

**Geoprobe® Sampling**

SOP 3-1

Revision: 7

Date: February 2015

- Screw the drive head onto the top end of the sample tube.
  - If using Teflon liner, insert liner into sample tube.
  - Slide the piston rod into the sample tube, leaving the piston tip sticking out of the bottom end of the sample tube.
  - Screw the piston stop-pin onto the top end of the piston rod in a counter-clockwise direction.
2. Attach the assembled sampler onto the leading probe rod. A 30-cm (12-inch) probe rod is recommended to start the DT and MC samplers.

**Probing**

3. Thread the drive cap onto the top of the probe rod and advance the sampler. Replace the 30-cm (12-inch) rod with rod appropriate for the stroke of the rig as soon as the top of the sampler is driven to within 15 cm (6 inches) of the ground surface.
4. Advance the sampler to the interval to be sampled using the hydraulic hammer. Add additional probe rods as necessary to reach the specified sampling depth.

**Stop-Pin Removal**

5. Move the probe unit back from the top of the probe rods and remove the drive cap.
6. Lower the extension rods into the inside diameter of the probe rods using extension rod couplers to join the extension rods.
7. Attach the extension rod handle to the top extension rod and rotate the handle clockwise until the leading extension rod is screwed into the piston stop-pin. Continue to rotate the handle clockwise until the stop-pin disengages from the drive head.
8. Remove the extension rods and attached piston stop-pin from the probe rods.

**Interval Sampling**

9. Replace the drive cap, mark the top probe rod with a marker or tape at a distance above the ground equal to the length of the sample tube.
10. Advance the probe rods using the hydraulic hammer the length of the sample tube.
11. Replace the drive cap with the pull cap and retract the probe rod(s). Secure the rod(s) with a clamp or by hand during removal so they do not fall back down the resulting borehole.
12. Detach the sampler from the lead probe rod, verifying that sufficient sample volume was recovered (Note: The length of sample contained within the tube is approximately equal to the length of exposed piston rod).
13. Disassemble the sampler. If the sample is to be analyzed for VOCs, then the sample tube or liner shall be sealed immediately by placing a Teflon septa over the ends and covering them with plastic caps.
14. If samples do not require VOC analysis, they may be extruded from the sampler and transferred to the sample jars specified in the site-specific plans or SOP 2-1, Packaging and Shipping Environmental Samples. Samples can be extruded by one of two methods:
- Using the Geoprobe rig and the extruder rack (Figure 2), position the extruder rack on the foot of the Geoprobe derrick; insert the sample tube into the extruder rack with cutting end up; and position the extruder piston, pushing the sample out of the sample tube using the “probe” function. Catch the sample as it exits beneath the extruder in a sample jar or stainless steel mixing bowl.

**Note:** Samples to be collected for VOCs will be collected directly from the sample tube into the sample jars.

**Geoprobe® Sampling**

SOP 3-1

Revision: 7

Date: February 2015

- Lightly tap the side of the sample tube with a hammer while also lightly pushing the Piston Rod.
15. Label the sample liner or sample jars as required, securing the label by covering it with a piece of clear, waterproof tape.
  16. Homogenize the sample in a stainless steel bowl with a stainless steel spoon or spatula. Transfer the sample from the bowl to the sample container.
  17. Clean the outside of the sample jars and place individual samples into sealable bags and seal the closure.
  18. Place samples in a cooler containing ice according to SOP 2-1, Packaging and Shipping Environmental Samples.

**Continuous Sampling**

The DT21/22, DT325/35, DT45, DT60, MC5, and MC7 are direct push systems for collecting continuous core samples of unconsolidated materials from within sealed probe rods. Samples are collected and retrieved within a liner that is threaded onto the leading end of a string of Geoprobe rods inserted to the bottom of the outer casing.

**5.2 Soil Gas Sampling****Assembly**

1. Assemble the sampling device as follows (Figure 3):
  - Test fit the adapter with the PRT expendable point holder or retractable point holder to ensure that threads are compatible and fit together smoothly.
  - Attach the PRT adapter to flexible tubing equal in length to the depth of sampling, with some additional tubing for sampling activities.
  - Secure the PRT adapter with a length of electrical tape and check the condition of the O-ring attached to the end of the PRT adapter.
  - Screw the PRT expendable point holder into the bottom of the lead probe rod.
  - Attach an expendable drive point to the bottom of the PRT expendable point holder.
2. Attach the assembled sampler onto the leading probe rod. A 30-cm (12-inch) probe rod is recommended to start the standard and large bore samplers.

**Probing**

3. Thread the drive cap onto the top of the probe rod and advance the sampler. Replace the 30-cm (12-inch) rod with rod appropriate for the stroke of the rig as soon as the top of the sampler is driven to within 15 cm (6 inches) of the ground surface.
4. Advance the sampler to 30 cm (1 ft) past the interval to be sampled using the hydraulic hammer. Add additional probe rods as necessary to reach the specified sampling depth.
5. Connect the out-of-hole tubing to a vacuum or sampling system. A short section of inert silicon tubing may be connected to the end of the out-of-hole tubing so that a sample can be collected with a glass gas chromatograph (GC) syringe.
6. Start the vacuum or sampling system and allow the system to operate for 2 to 3 minutes to ensure that a sufficient volume of air has been run through the tubing. Document the depth, vacuum pressure, and purge duration in logbook.

**Note:** Make sure the vacuum evacuation pump is able to pull vapors from the formation. Excessive vacuum may occur in clay/clayey units resulting in insufficient sample volume.

7. Collect sample using the method specified in the site-specific plan.

**Geoprobe® Sampling**

SOP 3-1

Revision: 7

Date: February 2015

8. Label all sample containers as required, securing the label by covering it with a piece of clear, waterproof tape.
9. Remove the tubing from the probe rods. Dispose of the tubing or set it aside for decontamination.
10. Remove probe rod(s) from hole. Leave tubing in place for longer term monitoring.

**Other Vapor Sampling Options**

1. The Vacuum/Volume System is a combined pump and tank system. In typical operation this tank is pumped down with the system vacuum pump. The vacuum pump is then shut off and the tank is opened to the soil gas sampling train. By measuring the change in pressure in the tank, the soil gas sampling can be performed at the same pressure at each sampling point, improving the comparability of samples.
2. Vapor Implants are permanent sampling points inserted into the subsurface for ongoing monitoring. Implants are stainless steel screens that can be inserted down the bore of a probe rod and anchored at depth. As probe rods are removed from the hole, the implant and associated tubing remain firmly anchored at the bottom and available for ongoing sampling.

**5.3 Groundwater Sampling****Assembly**

1. Assemble the screen point groundwater sampler as shown on Figure 4 and described below (see Geoprobe Systems website, Groundwater Assessment Tools):
  - Push the screen insert and plug into the screen sleeve from the bottom. The bottom end has one drain hole.
  - Push the screen connector over the top end of the screen sleeve and push the screen connector pin into place. The pin must be held in place as it has a loose fit.
  - Insert the screen sleeve, screen connector first, into one end of the sampler sheath.
  - Slide the drive point seat over the end of the screen assembly that protrudes from the sampler sheath. Thread it in until tight using a 22-mm (7/8-inch) wrench.
  - Push the screen assembly just far enough into the sampler sheath that an expendable drive point can be pushed into place in the drive seat.
  - Screw the groundwater drive head with the O-ring end first into the open end of the sampler sheath.
  - O-rings are installed at various critical places in the sampler assembly. Ensure that all O-rings have not been worn and that the connections made at O-ring locations are tight.
  - The mill-slotted well point does not need any assembly.
2. Attach the mill-slotted well point, or screen point groundwater sampler, onto the leading probe rod. A 30-cm (12-inch) probe rod is recommended to start either groundwater sampler.

**Probing**

3. Thread the drive cap onto the top of the probe rod and advance the sampler using either the hydraulic hammer or hydraulic probe mechanism on the Geoprobe rig. Replace the 30-cm (12-inch) rod with rod appropriate for the stroke of the rig as soon as the top of the sampler is driven to within 15 cm (6 inches) of the ground surface.
4. Advance the sampler to the interval to be sampled using the hydraulic hammer. Add additional probe rods as necessary to reach the specified sampling depth.

**Developing and Sampling**

6. Move the probe unit back from the top of the probe rods and remove the drive cap.

**Geoprobe® Sampling**

SOP 3-1

Revision: 7

Date: February 2015

7. The next step varies depending on the type of sampler being used:
  - Mill-slotted well point - measure and record the water level, allowing time for the water level to reach equilibrium.
  - Screen point groundwater sampler - attach the pull cap to the top probe rod, retract the probe rods approximately 60 cm (2 ft), push the screen into the formation using extension rods fitted with a ram, remove extension rods from the probe rods, and measure and record the water level, allowing time for the water level to reach equilibrium.
8. Surging and purging shall be conducted throughout the length of the exposed screen to properly develop the well point before sampling.
9. Label all sample containers as required, securing the label by covering it with a piece of clear, waterproof tape.
10. Collect groundwater samples using one of three methods (as outlined in site-specific plans) described below:
  - Collect sample from the inside diameter of the probe rods using a decontaminated mini-bailer. Follow SOP 1-5, Groundwater Sampling Using a Bailer.
  - Collect sample using a peristaltic pump and flexible tubing system.
  - Collect sample using a check valve (Waterra-type valve) attached to the bottom of 10-mm (3/8-inch) diameter tubing. The tubing is lowered into the probe rods below the top of the water table, check valve-end first. Water sample is collected through the tubing by rapidly oscillating the tubing up and down creating an inertial pump.
11. Clean the outside of the sample containers and place individual samples into sealable bags and seal closure.
12. Place samples in a cooler containing ice according to SOP 2-1, Packaging and Shipping Environmental Samples.

**5.4 Pneumatic Slug Testing****Assembly**

1. Assemble the screen point groundwater sampler and the pneumatic manifold assembly as shown on Figure 5 (see Geoprobe Systems Instructional Bulletin No. MK3181).
2. Be sure to accurately document all well construction parameters and site geologic information:
 

|   |  |
|---|--|
| <ul style="list-style-type: none"> <li>▪ Effective screen length (includes sand or filter pack)</li> <li>▪ Height of water column in well</li> <li>▪ Radius of filter pack</li> <li>▪ Radius of transducer and cable (for wells 1-inch diameter or less)</li> <li>▪ Depth of transducer below static water level</li> <li>▪ Saturated thickness of the aquifer</li> </ul> | <ul style="list-style-type: none"> <li>▪ True screen length</li> <li>▪ Screen radius</li> <li>▪ Casing radius</li> <li>▪ Static water level from a fixed reference point</li> <li>▪ Total depth of well from a fixed reference point</li> <li>▪ Initial head change</li> </ul> |
|---|--|
3. Once the pneumatic head is in place, a vented pressure transducer assembly is installed. The transducer itself is inserted through the port on top of the pneumatic head and lowered into the well about 2-feet below the static water level and off the bottom of the well.
4. Let the transducer equilibrate to ambient groundwater temperature and then zero out the transducer.

**Testing**

5. Set up slug test data acquisition software and select preferred options (refer to Instructional Bulletin No. MK3087).
6. Close inlet and release valves and close the pressure regulator on the manifold assembly.

**Geoprobe® Sampling**

SOP 3-1

Revision: 7

Date: February 2015

7. Adjust zero setting on pressure gauge, if needed.
8. Operate foot pump to pressurize supply hose to approximately 30 to 40 psi.
9. Open inlet valve on pneumatic head.
10. Slowly open the pressure regulator. From the fully closed position it takes about five revolutions to begin opening the regulator. Observe the pressure gauge on the pneumatic head (scaled as inches of water). Let the pressure in the well head rise slowly to a few inches above the level desired for testing (e.g. if you want to initiate the slug test with  $H_0$  of 10 inches let the gauge rise to about 12 inches).
11. Quickly close the inlet valve and allow the pressure observed from the transducer in the well head to return to equilibrium and stabilize. Record the stabilized gauge pressure. The readings shall return to the levels noted before pressurization was started.
12. Leak test the fittings on the pneumatic head and connection to the rods with a soapy fluid. Tighten fittings if necessary and retest. It is preferable to locate and correct any slow leaks before continuing with the slug test.
13. Once the transducer readout is back to equilibrium and stable, the slug test is ready to initiate. The slug test is initiated by opening the release valve as quickly as possible.
14. A very rapid initial drop in the transducer readout (head) shall be observed as the air pressure is released. Then the rise or recovery of the water level to the pre-test equilibrium level (baseline) will occur. Once the water level has returned to the pre-test level and is stable, the slug test is complete.
15. It is strongly recommended that at least three slug tests are run using different initial head values ( $H_0$ ) to verify appropriate well performance and development. If there is significant deviation between the repeat tests, additional development of the well or sampler may be necessary.

Geoprobe Systems has designed a simple user-friendly software package and data logger that allows acquisition and filing of pneumatic transducer data on a laptop computer. The data files are stored in ASCII format for easy export to spreadsheet and data analysis programs. The selection and application of the appropriate data analysis methods is beyond the scope of this SOP for field techniques.

## 6.0 Restrictions/Limitations

Smaller diameter Geoprobe sampling systems are not designed for collecting large sample volumes, thereby limiting the number of analytical parameters. Soil sample recovery will be poor in soils. Production rates will vary substantially depending on sampling depths/intervals, subsurface conditions, and the platform used. However, a minimum of between 10 and 15 samples per day can be expected in most situations.

The most efficient sampling depth is limited by the geologic and hydrogeologic conditions. Practical, efficient sampling depths shall be limited to approximately 6 meters (20 feet) under most conditions. However, sampling depths in excess of 30 meters (100 feet) have been achieved in unconsolidated, homogeneous sandy soils using heavy duty platforms and MC5 tools. Attainable depths will be greatly reduced in more consolidated and indurated formations and in soils with gravel and cobbles.

The presence of gravel and cobbles in soils will likely damage soil sampling tubes and possibly probe rods, couplers, stop-pins, and other probing equipment. A sufficient supply of replaceable equipment shall be kept on site in the event of damage or breakdowns. Replacement may be at the project's - not the subcontractor's - expense. The Geoprobe Systems website shall be accessible onsite; Geoprobe Systems provides overnight deliveries. MIP tooling is expensive and more fragile than standard soil sampling tooling and may not be appropriate in dense formations or formations with substantial amounts of gravel and/or cobbles.



**Geoprobe® Sampling**

SOP 3-1

Revision: 7

Date: February 2015

Before conducting the Geoprobe sampling event, underground utilities and structures must be demarcated on the ground surface. The local utility companies must be notified at least 72 hours before the scheduled sampling event to allow sufficient time to locate and mark the utility lines. The selected sampling location shall be a safe distance from the demarcated utility. In some cases, records regarding utility locations may not exist. In any event, a good practice is to slowly push the probe rods the first few feet (rather than hammering) to ensure that no utilities, underground storage tanks, or other subsurface structures are present.

**7.0 References**

Department of Defense. *Environmental Field Sampling Handbook, Revision 1*. April 2013 or current revision.

Geoprobe® Systems. 2015. *Standard Operating Procedure*. < <http://geoprobe.com/literature/...>>.

U.S. Environmental Protection Agency, Region IV. *Science and Ecosystem Support Division, Operating Procedure SESDPROC-300-R3*. August 2014 or current revision.

**Figure 1**  
**Geoprobe® Unit**

**BASICS**

- HYDRAULICALLY POWERED PROBE OPERATES FROM HYDRAULIC SYSTEM DRIVEN FROM THE VEHICLE OR AN AUXILIARY ENGINE.
- REMOTE VEHICLE IGNITION ALLOWS OPERATORS TO START VEHICLE ENGINE FROM REAR COMPARTMENT.
- BELT DRIVEN HYDRAULIC PUMP SUPPLIES 10 GPM AT 2000 RPM, 2250 PSI OPERATING PRESSURE.
- PROBE UNIT FOLDS FOR TRANSPORT AND SETS UP AGAIN IN SECONDS.
- UTILIZES STATIC FORCE (WEIGHT OF VEHICLE) AND PERCUSSION TO ADVANCE PROBING TOOLS.
- POWERFUL 8 HP HYDRAULIC HAMMER DELIVERS OVER 1800 BLOWS PER MINUTE.
- HAMMER FEATURES 0-300 RPM LH DIRECTIONAL ROTARY FUNCTION FOR DRILLING SURFACE PAVEMENTS.
- PROBE HAS GREATER THAN 12,000 LBS. OF PULLING CAPACITY.
- DRIVES SMALL DIAMETER (1" O.D. - 1.6" O.D.) PROBING TOOLS TO DEPTHS LIMITED ONLY BY SOIL TYPE AND DEPTH TO BEDROCK, TYPICALLY TO OVER THIRTY FEET.

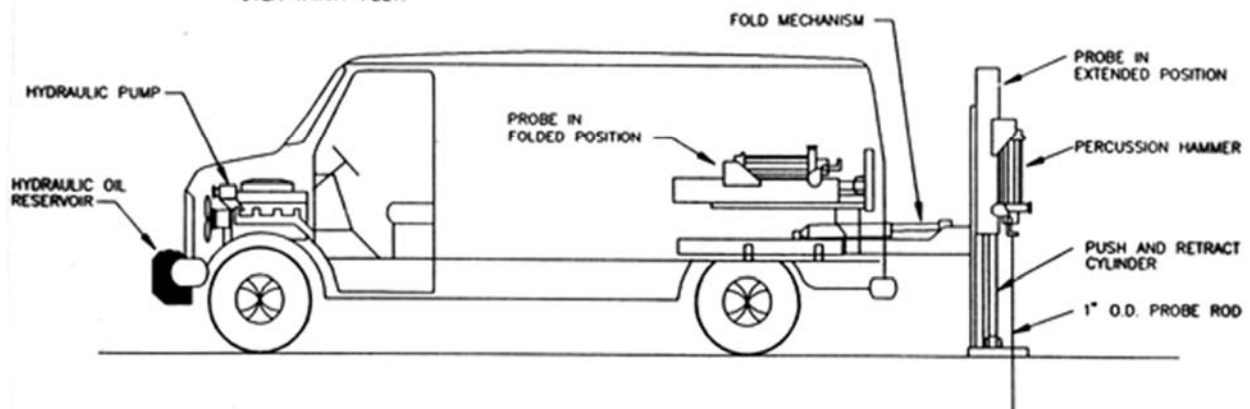

Figure 2  
Sample Extruder Rack

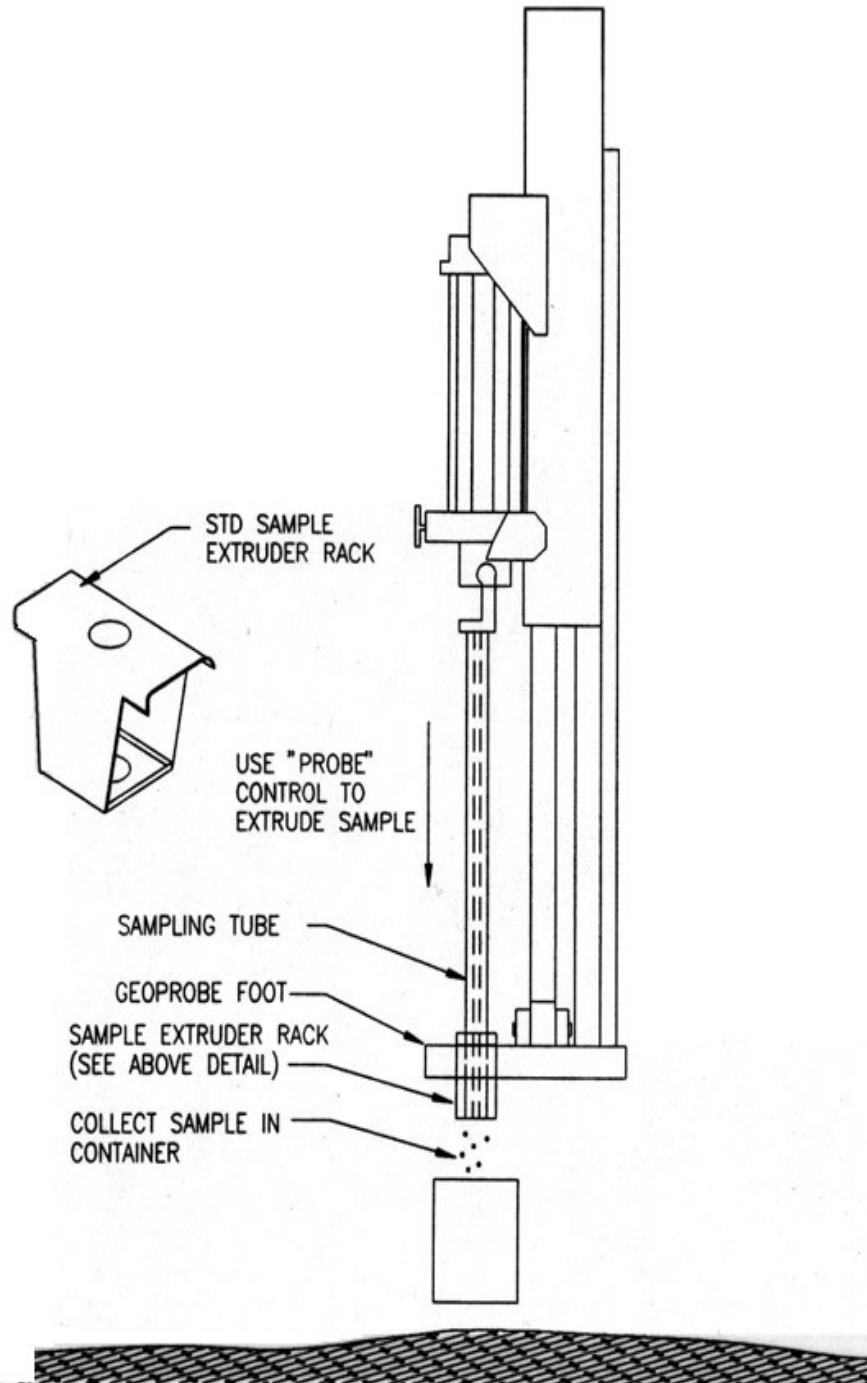
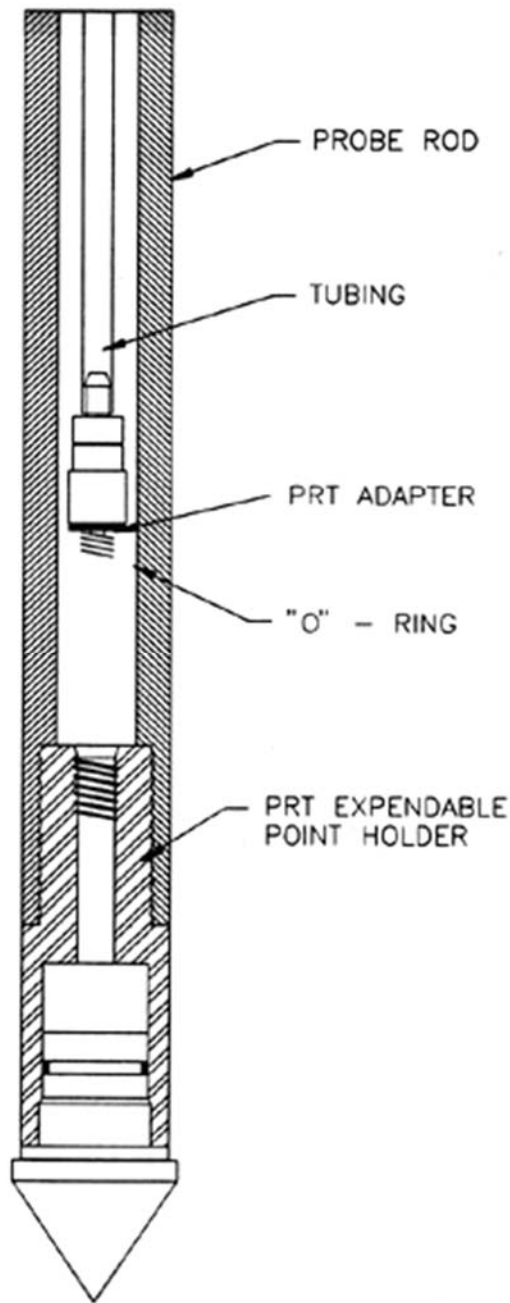
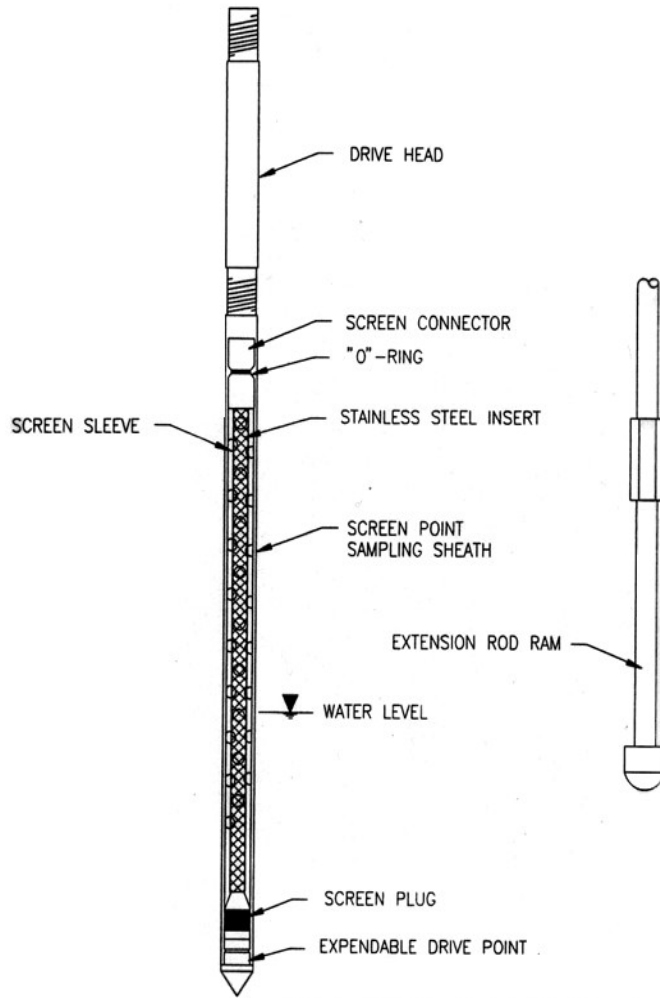

Figure 3  
PRT Soil Gas Sampling System



**Figure 4**  
**Groundwater Sampling**



**Figure 5**  
**Pneumatic Slug Testing with an SP15/16 Groundwater Sampler**

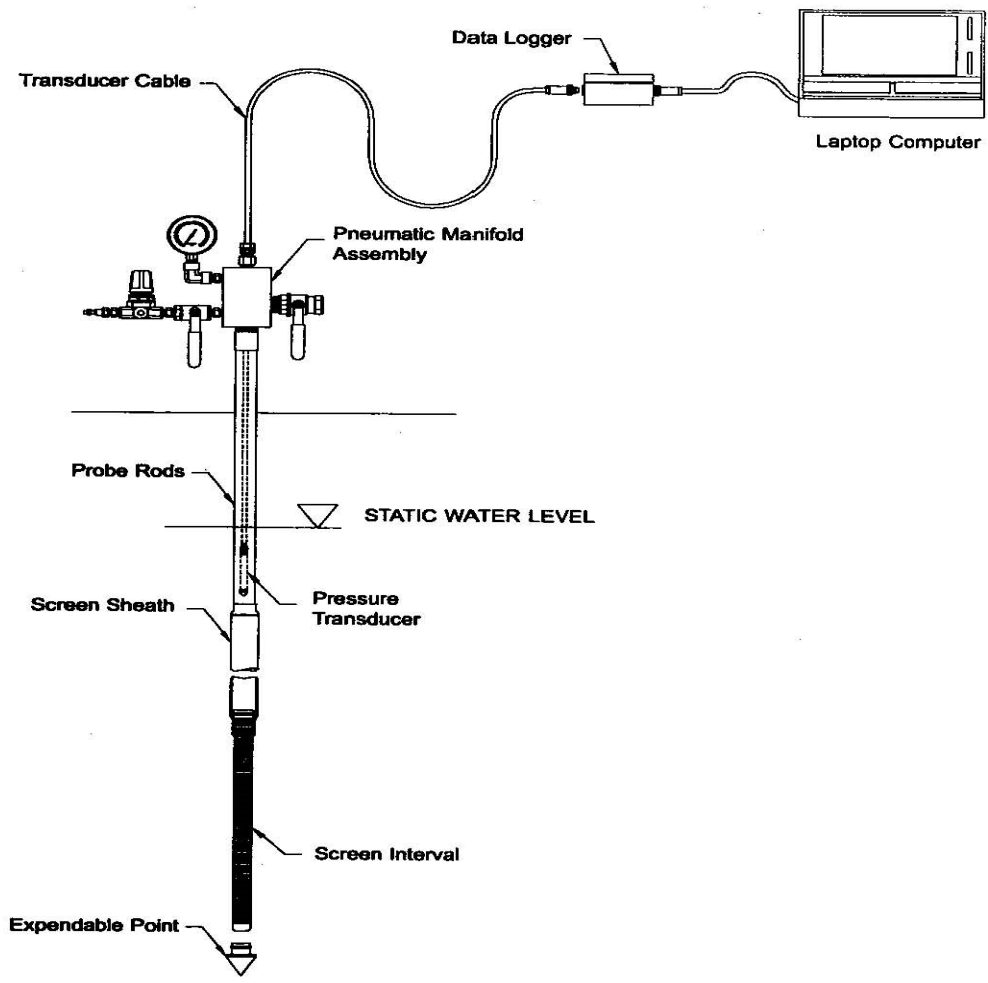

The

**Topographic Survey**

SOP 3-2

Revision: 8

Date: February 2015

Prepared:

  
Signature

Technical Review:

Todd Bragdon

**1.0 Objective**

The objective of this technical standard operating procedure (SOP) is to provide guidance for a site topographic survey. The survey will produce a base map of the area under study, showing topographic and site-specific features. Also, the base map will incorporate site-specific grid system coordinates, if appropriate, to show sample and exploration location, monitoring wells, test pits, and any other features required by the scope of work.

**2.0 Background**

A site-specific grid system may be established at the area under study to coordinate the collection of samples. The topographic survey will establish the coordinates for the grid and facilitate the transposition of the grid and sample locations from the field to the topographic base map. At areas where a grid system is not used, sample and exploration locations will be marked by the field team using appropriate markers such as stakes, nails, flagging, or paint. The base map will also locate site-specific planimetric details such as significant manmade and geographic features via the survey. In developing the topographic survey scope of work (SOW), considerations for the initial base map development should also include future project needs such as engineering design.

The scale for the base maps will vary based on the size of the area under study, but a suitable scale will be selected that clearly shows map features and sample locations. The base maps will be at a scale appropriate for the intended use. Areas with significant detail requirements will be shown in scale that ranges from 1 inch equals 10 feet to 1 inch equals 40 feet. Areas with less detail requirements will be shown in smaller scale such as 1 inch equals 100 feet or 200 feet. Topography will be shown with 1- or 2-foot contour intervals. However, the contour interval shall clearly identify the variation in topography to the degree necessary for the work to be performed. For example, gently sloping areas may require a smaller contour interval (i.e., 1 foot between contour lines) to reveal more subtle topographic variations. Similarly, steeply sloping areas may require larger contour intervals to legibly depict the topography. Index contours shall be indicated at elevations that are multiples of five times the contour interval.

If appropriate, aerial photographs (i.e., orthorectified imagery) may be used to assist in the development of the topographic base maps. Existing or new photographs can be used for this purpose. In areas with deciduous trees, new photographs shall be taken during late fall or winter when the leaves are off the trees and better ground surface image can be achieved. The scale of the aerial photographs shall provide sufficient detail for developing the topographic base map.

**3.0 General Responsibilities**

**Project Manager** - The project manager is responsible for ensuring that the topographic survey is completed in accordance with the project requirements.

**Field Team Leader** - The field team leader is responsible for developing the survey scope of work and ensuring that the topographic survey is coordinated properly with the grid system (if used) and the sampling points, so that the base map produced is a true representation of the field locations.

**Note:** Responsibilities may vary from site to site. Therefore, all field team member responsibilities shall be defined in the field plan or site-specific/project-specific quality assurance plan.

**4.0 Required Equipment**

The required equipment for a topographic survey shall be provided by the selected surveyor. All equipment proposed by the surveyor shall be submitted to CDM Smith for approval before initiating the topographic survey work.

The selected surveyor must be licensed professional surveyor (PLS) in the state in which the survey is conducted.

**Topographic Survey**

SOP 3-2

Revision: 8

Date: February 2015

For topographic surveys conducted at hazardous waste sites, all surveyor personnel who work onsite will be 40-hour health and safety trained per OSHA requirements for hazardous waste sites (29 CFR 1910.120), unless approved differently by the corporate health and safety manager.

All final drawings and maps must be signed and sealed by the licensed professional land surveyor.

**5.0 Procedures**

1. A site visit may be conducted before submitting the bid proposal. A kickoff meeting shall be held between the selected surveyor and CDM Smith's project manager to discuss the specific requirements of the scope of work.
2. The surveyor shall be responsible for executing the work, including deed search if required to support development of a legal description of the site or to establish property ownership boundaries.
3. The surveyor shall develop and implement a site-specific health and safety plan according to the requirements specified in the subcontract between CDM Smith and the surveyor.
4. To the extent practical, the work shall be performed in the presence of an authorized representative(s) of CDM Smith. CDM Smith will interpret and clarify the specifications and will answer all questions in connection therewith.
5. The CDM Smith field team leader will be responsible for ensuring that appropriate calibration procedures are performed and documented by the surveyor. Calibration procedures shall be consistent with the data quality objectives for the survey and with the equipment manufacturers' requirements.
6. The surveyor shall establish at least one primary horizontal control monument and one vertical benchmark, as established by the United States Coastal and Geodetic Survey (USC&GS) or equivalent authority. Additional monuments may be established by the surveyor.
7. Local benchmarks will be established at least every 500 feet or closer, if warranted by site conditions, to tie the basic control points together. Where required, established horizontal and vertical data, such as state planar coordinate systems and the national geodetic vertical datum of NAVD 88 or subsequent corrections and/or revisions, shall be used to tie the survey data to the national network.
8. Temporary monuments will be set as necessary to perform the surveying. They may be wood, metal, or otherwise marked on facilities such as sidewalks, paved streets, curbs, etc. All monuments shall be described in the field notes and marked on site maps for future reference.
9. If appropriate, the surveyor shall be encouraged to use technologies such as Global Positioning System (GPS) that will meet the accuracy requirements but that may be more flexible and efficient than traditional techniques. All geodetic control work shall conform to either the Standards and Specifications for Geodetic Control networks, Federal Geodetic Control Subcommittee or NAVSTAR Global Positioning System Surveying, U. S. Army Corps of Engineers, for third order Class II control surveys. Short traverses, less than 1 mile, may use generally accepted fourth order techniques (including vertical angles for elevations) that will provide the spatial accuracy required. Angles shall be doubled and redoubled if the mean of the doubled angle differs from the first angle by more than 10 seconds. Length measurements shall be made with a calibrated tape corrected for temperature and tension or with Electronic Distance Measuring (EDM) equipment corrected for variation of the index of refraction.
10. The CDM Smith field team leader will review the draft map to ensure that all sampling and exploration locations, grid coordinates, and other appropriate features are located by the surveyor. The surveyor will record all field survey information in a field logbook; a copy of the logbook shall be provided to CDM Smith with the submittal of the topographic map.



**Topographic Survey**

SOP 3-2

Revision: 8

Date: February 2015

11. A working drawing of the base map will be field checked and corrected by the surveyor as necessary. The completed topographic base map shall be plotted on Mylar® or other suitable drafting film, as directed by the CDM Smith project manager. All survey and topographical data will be in digital format, compatible with the latest version of AutoCAD, ArcView/ArcInfo, DXF, or geographic information system (GIS) export format may also be acceptable. The specific format of the data to be provided to CDM Smith will be specified in the SOW. It is recommended that a review of CDM Smith client requirements be completed to determine the appropriate data format. Sufficient documentation of the digital information shall be provided to explain the data. For clarity, the surveyor will prepare the base map with groups of features on separate layers in the AutoCAD files. The CDM Smith project manager shall designate which features will be placed on the separate layers. Tick marks indicating the latitude and longitude in the state that the work is performed shall be provided on the base map. The project manager will be responsible for ensuring that the topographic base map and digital information is completed according to CDM Smith's drafting standards for the project; it is recommended that CDM Smith's drafting standards be included in the SOW to ensure clear communication of project requirements.
12. In the event that aerial photographs are used, the surveyor shall field edit and statistically test the aerial topographic mapping of the site base map for conformance with the horizontal and vertical components of the National Map Accuracy Standards. The surveyor shall run random baselines throughout the site (minimum of four) to verify that less than 10 percent of horizontal and/or vertical locations exceed the values determined in the National Map Accuracy Standards. If more than 10 percent of the locations exceed the values in the National Map Accuracy Standards, then the surveyor will notify CDM Smith. The project manager will be responsible for ensuring that the orthorectified aerial photographs files are transferred electronically to CDM Smith along with other required deliverables in the SOW.
13. Stereo map compilation by stereo photogrammetric methods will be accomplished through the use of approved stereophotogrammetric instruments using professionally recognized plotting ratios for each type of instrument. Fully trained and experienced photogrammetrists will be employed to complete stereomapping compilation.
14. For broad area high precision topographic mapping, digital elevation/terrain model (DTM) compilation using light detection and ranging (LiDAR) technologies is becoming more common. This method can be an efficient and effective tool for increasing engineering production at all levels. However, the error budget for a given LiDAR mapping system is dependent on the accuracy of its core subsystems (i.e., the laser rangefinder, the GPS position solution, and the inertial measurement unit [IMU]). System engineers need to balance each subsystem contribution against desired system performance (Shrestha et al. 2000). The project manager will be responsible for ensuring that the DTM files are transferred electronically to CDM Smith along with other required deliverables in the SOW. DTM files can be utilized by AutoCAD Civil 3D for future modeling of the site.
15. The surveyor shall establish and maintain a quality control program to ensure that the survey is performed within acceptable limits. At a minimum, the surveyor will:
  - Check all equipment, including compasses, transits, and levels, for accuracy and maintain records of such checks. The surveyor will make records of these checks available to CDM Smith on request.
  - Maintain and submit copies of all survey field notes.
  - Field notes for each surveying activity will be kept in bound books dedicated exclusively to this project. Each book will have a table of contents. Each page of field notes shall be numbered, dated, and show the initials of all crewmembers. Black waterproof ballpoint pens will be used. Erasing is not acceptable. All errors will be crossed out with a single line and the correct data entered adjacent to the error. The crossed out and corrected data will be initialed by the party marking field notes.
16. Permits:
  - The surveyor shall be responsible for obtaining any federal, state, and local permits that may be required and to perform and complete the ground surveys at the site.
  - The surveyor shall not perform any work until permits (if required) are obtained.
  - The surveyor shall provide separate copies of all permits to CDM Smith before performing any onsite activities.

## Topographic Survey

SOP 3-2

Revision: 8

Date: February 2015

### 6.0 Restrictions/Limitations

The horizontal positions are to be surveyed within 1/10 of a foot, relative to the datum coordinate system. The vertical elevations of monitoring wells, piezometers, and staff gauges are to be surveyed within 1/100 of a foot (0.01 foot), relative to the local benchmarks. The vertical elevations of all other sampling points are to be surveyed within 1/10 of a foot, relative to the local benchmarks.

### 7.0 References

U. S. Department of Commerce, National Geodetic Survey (see <http://www.ngs.noaa.gov>).

Moffitt, F.H. and Bouchard, H. 1982. *SURVEYING* (10<sup>th</sup> ed.), Harper and Row, Publishers, New York.

Shrestha, R. L. et al. 2007\_Version 1.2. *Airborne Laser Swath Mapping: Accuracy Assessment for Surveying and Mapping Applications*. University of Florida (see [http://ncalm.berkeley.edu/reports/NCALM\\_WhitePaper\\_v1.2.pdf](http://ncalm.berkeley.edu/reports/NCALM_WhitePaper_v1.2.pdf)).

## Geophysical Logging, Calibration, and Quality Control

(Includes Potential Radioactive Sites)

SOP 3-4

Revision: 7

Date: February 2015

Approved:

  
Signature

Technical Review:

Michael Valentino

### 1.0 Objective

The objective of this technical standard operating procedure (SOP) is to provide guidelines and define requirements for the generation of quantifiable geophysical logs of selected boreholes. The procedure defines use of a logging systems check, calibration and maintenance check, and well maintenance data documentation.

### 2.0 Background

Geophysical logging can be used to interpret the physical characteristics surrounding a borehole. These characteristics include the lithology, geometry, resistivity, formation resistivity factor, bulk density, porosity, permeability, structural integrity, and moisture content. Logging can also be used to evaluate well integrity and characterize vertical groundwater flow and groundwater quality within the water column. Interpretations from tool response can be used in a more quantitative fashion when the instruments used during a specific logging process are accurately and properly calibrated and operated by trained personnel. To provide consistently reliable data, a logging operator needs to ensure the following: proper tool calibration or standardization maintenance checks, a logging systems check, complete and well-maintained data documentation, and identification and protection against potential hazards.

#### 2.1 Associated Procedures

- SOP 4-1, *Field Logbook Content and Control*

### 3.0 General Responsibilities

**Site Manager** - The site manager translates client requirements into technical direction of the project. The site manager plans and directs the overall project; sets technical criteria; reviews and approves technical progress; defines or approves what logs and tools are to be used after consultation with the field team leader; and considers the objectives of the project, the lithology surrounding the borehole, and the borehole conditions.

**Field Team Leader** - The field team leader (FTL) provides onsite supervision of the borehole logging program, administers the logging subcontractor operation, and ensures that this SOP is properly followed at all times. The FTL confers with the site manager and the logging subcontractor on what logs and tools are to be used and maintains the field logbook in accordance with SOP 4-1, Field Logbook Content and Control. The field team leader provides the logging subcontractor with a unique, site-specific document control or ID number for use in identifying each individual borehole or well, provides copies of checklists pertinent to the operation, and provides copies of borehole or well construction details.

**Logging Subcontractor** - The logging subcontractor provides equipment appropriate to the task as described in the project statement of work, provides appropriately trained and qualified personnel, and responds to administration of the FTL. The logging subcontractor ensures proper tool calibration or standardization maintenance checks, a logging systems check, complete and well-maintained data documentation, and identification and protection against potential hazards. The logging subcontractor ensures that logging subcontractor personnel read and observe requirements defined in this SOP and provides copies of their company standard and emergency operating procedures for approval by FTL before implementing any logging activities.

**Note:** Responsibilities may vary from site to site. Therefore, all field team member responsibilities shall be defined in the field plan or site-/project-specific quality assurance project plan (QAPP).

### 4.0 Required Documentation

- Field logbook
- Appropriate log sheets (boring logs, well completion data sheets, or equivalent)

## Geophysical Logging, Calibration, and Quality Control

(Includes Potential Radioactive Sites)

SOP 3-4

Revision: 7

Date: February 2015

- File containing:
  - a) One copy of the logging contract stating the technical requirements
  - b) One approved copy of logging subcontractor SOPs and emergency operating procedures
  - c) One copy of the current Nuclear Regulatory Commission (NRC) license listing certifications and approval of the type and activity level of the radioactive sources to be used onsite, if appropriate
  - d) One copy of the current leak test (swipe) results of all radioactive sources containers on board the logging vehicle
  - e) Physical survey forms indicating activity level at monitoring points adjacent to the radioactive source storage area of the logging vehicle
  - f) Documentation of current radiation monitoring instrument calibration
  - g) Documentation that all geophysical tools have been inspected and are properly operating
- Site-Specific Checklists (see attached examples)
  - a) Health and Safety Checklist (Attachment 1)
  - b) QA Geophysical Checklist for Borehole Logging (Attachment 2)
  - c) Geophysical Logging Tool Checklist (Attachment 3)
  - d) Example Log Heading (Attachment 4)

## 5.0 Procedures

### 5.1 Preparation

The site-specific health and safety plan shall be reviewed along with project plans before initiating logging activities. The logging subcontractor and the FTL or designee will confer before field activities regarding the suite of geophysical tools to be used in the operation. The FTL shall define what logs are to be used.

Considering the objectives of the logging program, the choice of tools may be further determined by the lithology surrounding the borehole and the borehole conditions. Prior logs will be used, if available, as aids to determine the appropriateness of the logging suite. These logs will be studied and serve as a baseline for the current logging activity.

Generally, fluid logs are run first within a logging suite with nuclear logs last. In uncased holes, a caliper log shall be run shortly after the fluid log, as it can yield measurements of the borehole rugosity and diameter variations useful in the onsite evaluation of uncompensated logs that may follow. Both are necessary in determining the borehole integrity and appropriateness and suitability of future logs.

The logging subcontractor shall have an approved emergency operating procedure covering all emergencies relating to tool operation, including the retrieval of a logging tool that has been lost down a hole. The logging subcontractor and FTL or designee will cooperate in determining the most suitable approach for retrieval of any tool.

**Note:** Some sites (such as the U. S. Department of Energy) require advance notification and approval before bringing any radiation source onto the site. This includes radioactive calibration check sources. The FTL will confirm that all site-specific requirements are met before mobilization of the logging equipment.

The following documents, certificates, and inspections will be completed by the logging subcontractor before well logging and shall be in an open, active file during logging activities.

- One copy of the current NRC license listing certifications and approval of the type and activity level of the radioactive sources to be used in the logging program.
- One copy of the current leak test (swipe) results of all radioactive sources containers on board the logging vehicle.
- Physical survey forms indicating activity level at monitoring points adjacent to the radioactive source storage area of the logging vehicle.
- Documentation of current calibration of radiation monitoring instrument.

## Geophysical Logging, Calibration, and Quality Control

(Includes Potential Radioactive Sites)

SOP 3-4

Revision: 7

Date: February 2015

- Copy of the logging SOP and emergency operating procedures to be followed during logging activities. Emergency procedures shall include provisions for retrieval of lost probes, with physical descriptions and drawings of the probes and head connections available at the well site.
- Documentation that all geophysical tools have been inspected and are properly operating.

Before proceeding to the field site, each geophysical logging tool will be “shop calibrated.” The shop calibration (or standardization) is a method of subjecting the energized probe to a known signal level to ascertain the integrity of the logging equipment. These offsite standardization trials will be available for comparison to onsite calibration or standardization, which will be performed before and after each logging tool run. American Petroleum Institute (API) calibration scales are not usually applicable to geophysical logs made in cased holes, and log headings, in such cases, shall not exhibit environmental units or any other nonapplicable scales. Radiation logs, made through steel casing, shall display nonenvironmental “shop calibration” scale units, such as counts per second, counts per minute, or API units.

### 5.2 Operation

After all required equipment and material have been mobilized onsite and necessary consultations and preparations are completed, the field operations may begin. During field activities, to ensure the safety and quality of operations, a Health and Safety Checklist (Attachment 1) along with a QA Geophysical Checklist for Borehole Logging (Attachment 2) shall be completed.

Once at the site, each piece of logging equipment will go through routine standardization before and after the logging of every borehole using portable standards. All tool responses to each standard will be recorded on each borehole log trace. Personnel responsible for running the geophysical log shall perform the standardization of the logging equipment.

Calibrations and standardization will be recorded digitally.

Mechanical and electrical zero response and full scale settings will be recorded and labeled as such at the beginning of each logging trace.

Before logging any borehole, the FTL or designee will review the most up-to-date information on borehole conditions such as: depth, variations in diameter, lost circulation zones, casing, debris in hole, fluid type, and known contaminants (if any) in the borehole. Each logging procedure will be determined based on assessment of borehole conditions using the most recent and previously run logs (if available).

All probe O-ring seals will be thoroughly inspected to prevent potential water leaks from developing within the instrument. Seals shall be clean and dirt free.

All logging cables need to be kink free. Logging subcontractor personnel shall be prepared to wipe or clean cables before retraction onto the storage drum.

The cable measuring sheave between the winch and well must be pre-calibrated to the currently used cable size. The sheave shall be free of any debris (e.g., dirt, ice, or dry drilling mud).

Cable heads shall be checked for electrical leaks or shorts using a volt- or ohm-meter.

Before the completion of each logging suite, a geophysical checklist will be studied and completed, where appropriate, by the FTL or designee. All checklists will be completed in black indelible ink. The Geophysical Logging Tool Checklist (Attachment 3), to be completed by the logging subcontractor equipment operator, shall indicate the specific logging tools used, order of use, and the combination of tools used concurrently. A preview of the checklist by the logging subcontractor equipment operator will serve, in part, as a reminder of potential problems that may arise during the logging run.

An example log heading, as shown in Attachment 4, shall be used. The analog trace for each log will have all pertinent information (listed

## Geophysical Logging, Calibration, and Quality Control

(Includes Potential Radioactive Sites)

SOP 3-4

Revision: 7

Date: February 2015

below) written on the trace by the logging subcontractor equipment operator as it occurs. This may include:

- Depths per interval or division of log tracing paper
- Horizontal scale values (written at the start of each log)
- Scale changes (if done during a logging run)
- Pen positions
- Borehole/well identification
- Probe type
- Logging speed
- Tool calibration tails
- Module adjustments
- Digitized record information number

This information will be copied to a formal well log heading at the end of the logging run. Each log heading will give information relating to well and geophysical tool parameters. To interpret the well log as quantitatively as possible, it is imperative that all criteria and data entries within a log heading be filled out by the logging subcontractor equipment operator before the logging tool is removed from the cable. The completed heading will be attached to the well analog record at the well site. If required for the project, the FTL or designee may supply a unique site-specific document control or ID number written on both digital record and the log heading.

Borehole geophysical data stored on the laptop computer should be backed up to a USB drive in the field before leaving each borehole.

It is imperative that the logging operator continually monitor the data output on the laptop monitor to determine any spurious and anomalous conditions that may arise. A review of the geophysical checklist before logging will be done to prompt the logging subcontractor equipment operator of potential problems that might arise. The following briefly summarizes some of the potential problems associated with each logging technique. It shall not be a substitute for thorough training in the nuances and idiosyncrasies of specific instruments, as each tool used will have a unique circumstance that may result in a spurious log.

### A. Extraneous Conditions Resulting in Anomalous Logs

The following briefly describes conditions that may give rise to anomalous log traces and shall be watched for by the logging subcontractor equipment operator.

#### 1. Fluid Logging

In newly drilled holes, it is unusual to have chemical or thermal equilibrium between the borehole fluid and surrounding borehole matrix. Consequently, fluid logs generally measure the conditions of the borehole fluid rather than borehole matrix that sometimes requires months to reach equilibrium (this would be especially true if the hole was drilled using drilling mud and development was not properly performed).

#### *Temperature Logs*

The introduction of fluid or air to remove drill cuttings during the drilling operation causes false temperature anomalies often requiring months to reach equilibrium. Foreign material introduced into the annulus, especially curing cement, causes anomalies not related to formation properties. For these reasons, temperature logs in recently drilled holes shall not be interpreted as formation temperature logs. Temperature logs are not easily repeated due to disturbance of the fluid during initial entry. Therefore, formation or fluid temperature logs shall be done first and recorded as the probe descends down the borehole, generally long after the well has been developed.

Typical thermal gradients shall range between 0.47°C and 0.6°C per 30 meters (m) (100 feet) of well depth. If a log results in temperatures outside this range, extraneous effects affecting the log shall be considered. In rare instances, a log may be erroneous due to problems that arise within the probe such as thermal lag, electronic drift, and self-heating of the probe thermistor. Since these conditions are the exception and not the rule, other conditions shall be examined first as a result of questionable temperature logs.

Log traces that result in small temperature fluctuations near the fluid surface may arise from large diameter probes descending too

## Geophysical Logging, Calibration, and Quality Control

(Includes Potential Radioactive Sites)

SOP 3-4

Revision: 7

Date: February 2015

fast within the borehole and may not be representative of borehole conditions. Small temperature fluctuations with respect to depth may be a result of borehole conditions rather than improper tool operation. Inter-bore flow due to large head differential between aquifers can cause very small or even reversal of the thermal gradient. Fluid tracers or flow measurements may help to determine these effects.

Convection cells within the borehole can result in temperature readings that are unrelated to the flow of water within the borehole. This is especially true for boreholes that have large diameters, fracture zones, and washouts. Consequently, the more accurate temperature logs are taken in small boreholes with small diameter probes.

### **Conductivity Logs**

Conductivity logs measure the fluid conductivity within the borehole and are not always a measurement of interstitial water conductivity. Temperature drifts and movement of the probe in and out of steel casing material may give rise to sharp log deflections.

### **Flow Logs**

Impeller flow-meters (commonly called spinners) are generally less sensitive than heat pulse or tracer release methods. In many aquifers, water movement is predominantly in the horizontal direction, with substantial seepage velocity variations as a function of vertical position. In these cases, knowledge of hydraulic conductivity with vertical position is essential. These conditions can be investigated best by installing the impeller flow-meter below an operating pump or in flowing artesian wells. Inter-borehole flow can often be determined by the heat pulse or tracer release methods.

## **2. Caliper Logs**

Caliper log errors shall be questioned when one of the arm traces shows no deflections. Several conditions are suspect. Heavy drilling muds, most prevalent at the bottom of the borehole, can cause failure of caliper arms to open up. Nonextended arms may be jarred open by bouncing the probe up and down or simply moving the probe to a zone with thinner muds.

Boreholes with a large degree of rugosity may give rise to peculiar log traces, especially in arm-averaging traces. For these types of holes, it is recommended that nonaveraging or a single arm caliper be used. When a single arm caliper is used, repeat logs may not be exact duplicates of one another due to potential probe rotation.

Electrical leakage and grounding problems may cause spurious trace spikes.

## **3. Electrical Logging**

### **Spontaneous Potential (SP) Logs**

Stray electrical currents caused by underground cables, lightning strikes, corroding underground pipes, and nearby electrical motors can affect SP logs, inducing spikes or a uniform cyclical response. A repeat log will need to be done shall such interferences occur.

If the logging cable has become magnetized, the log trace will consist of a cyclical sinusoidal wave that corresponds to each revolution of the cable winch. The cable shall be demagnetized and the log rerun.

### **Single Point Resistance Logs**

Single point resistance logs are affected by electrical fields generated from underground cables. Alternating current from the underground cable becomes superimposed over the alternating current applied to the probe. This can be detected when the trace pen fluctuates when the probe is stationary. The problem can be alleviated by changing the current frequency applied to the probe electrode and double-checking while the pen is stationary.

### **Normal Resistivity Logs**

Nearby underground cables with currents of 60 cycles per second will produce an oscillating periodic logging trace. This problem can be alleviated by changing the current frequency applied to the probe from the generator or other power source.

A logging trace that appears to be cupped, or reversed, may be the result of an electrode spacing that is greater than the formation

## Geophysical Logging, Calibration, and Quality Control

(Includes Potential Radioactive Sites)

SOP 3-4

Revision: 7

Date: February 2015

thickness.

### **Induction Logs**

Problems will arise if the resistivity of the formation water is five times greater than the resistivity of the borehole fluid. As a double check, the inverse of induction measurements shall be in close agreement with formation resistivity measurements taken with other instruments.

### **4. Acoustical Logging**

Acoustical televiewer (ATV) logging relies on a rotating trigger switch that is activated when a sensor passes magnetic north. Lithologic formations that are composed of magnetized material, lost drilling equipment in the borehole, and metal casing will cause the switch to malfunction. Therefore, the logging operator will need to change the trigger switch to a mechanical mechanism if they suspect the presence of magnetically susceptible materials.

Boreholes that deviate from the vertical will require careful corrections on the ATV log; these corrections shall be noted on the logging trace. If the probe is not properly centralized, dark splotches will appear on the log. This may be exacerbated when coupled with low gains.

Acoustical logs are questionable when the log trace is composed of rapid fluctuations labeled as cycle skipping. This may be a result of several conditions, such as gains that are too small or too large. For example, an amplitude that is too small will result in the first compression wave being masked by pre-arrival "noise." Skipping may also be a result of borehole fractures, solution openings, attenuating rocks, or gas in the borehole fluid.

### **5. Nuclear Logging**

All nuclear logs will be run near the end of the logging suite. Borehole conditions will be carefully scrutinized for integrity and their suitability for nuclear logging during previously run logs within the logging suite. Confirmation that the borehole is suitable for nuclear logging will be between the FTL or designee and the logging operator. This will be noted on the nuclear logging checklist.

Any suspicions of potential problems arising during a nuclear log operation will be addressed immediately and resolved before further nuclear logging is carried out.

The following paragraphs briefly describe conditions that may give rise to anomalous nuclear log traces and shall be watched for by the logging operator.

#### **Natural Gamma (Gamma Ray) Logs**

The natural gamma log trace shall have maximum deflection with minimal statistical variation. Pulses of natural gamma radiation are collected and averaged over a predetermined time constant. If the time constant is too short, relative to the amplifier gain, the trace will be masked by spikes of statistical variation. If the time constant is too long, relative to the probe travel and amplifier gain, the log trace is rounded off and lacks resolution. Logging speed and time constant setting shall produce a trace with sharp anomalous peaks, with a minimum of clutter and maximum horizontal span.

Natural gamma logs are sensitive to borehole configurations and packing materials. Sudden trace deflections or changes in amplitude may be due to borehole diameter irregularities and drilling or well construction fluids; consequently, all gamma traces must be checked with a caliper trace.

Migration of water containing radioactive colloidal particles (i.e., clays or sylvite) through the borehole cracks and fissures will give traces that are not representative of the borehole matrix.

#### **Gamma-Gamma (Gamma Density) Logs**

Gamma-gamma logs are affected by borehole configuration, casing, cement, mud, probe "stand off," and background radiation. Therefore, a high resolution caliper log and background radiation check shall always be compared with the gamma-gamma log trace to differentiate whether the trace response is due to matrix porosity and density parameters or extraneous effects.

A 4-pi gamma-gamma density log, because of its capability to propagate energy in four directions, is very effective in evaluating the



## Geophysical Logging, Calibration, and Quality Control

(Includes Potential Radioactive Sites)

SOP 3-4

Revision: 7

Date: February 2015

integrity of material placed between the well casing and borehole walls. A thorough background check is especially critical to the success of this logging technique.

Attention shall be given to sharp trace deflections. These shall be compared to other logs as they may be due to the presence of cement boundary zones, the threaded interface between casing lengths, casing nested strings, and gravel packs. In the case of the 4-pi density log, these anomalous features are the target.

### **Neutron Logs**

Neutron logs are affected by the same borehole parameters as gamma-gamma logs (except borehole casing materials) but less dramatically. As with gamma-gamma logs, cross checks between high-resolution caliper logs, background radiation, and the neutron log shall be performed to adequately interpret the trace.

Large trace deflections will occur at the interface between fluids of different densities, such as a saline/fresh water or air/water interface.

The presence of clays and shales surrounding the borehole will give anomalously low trace responses, indicating high total porosity.

### **5.3 Post Operation**

All checklists shown in this SOP's attachments shall be filled out before leaving the site. These checklists are designed for health and safety, quality assurance, and tool operation.

At the end of each logging run (within a suite), the logging operator will complete the appropriate portions of the tool checklist. The checklist will then be verified by the FTL or designee. Any correction in data entry will be crossed out with a single line, dated, and initialed. At the end of the logging suite, each category in the checklist will have a handwritten entry. If a specific parameter does not apply, the logging operator will enter "N/A" by that category.

The original of all records will be given to the FTL or designee along with copies as may be specified. Copies of all completed checklists will also be provided.

To check for leaks, a radiation survey will be done on all nuclear probes. Shields will be checked for proper installation and defective components before probe storage. If shields of neutron sources have been found to be defective, storage before repair will be away from sodium-iodide crystals (a common component in some probe detectors) as they become radioactive when impinged upon by a neutron source.

All radioactive sources and radioactive tracers will be kept in a designated and carefully monitored storage area that has been specifically designed for storing or transporting nuclear sources. Sources stored within the facility will be sealed and placed in source holders specifically designed for their use. Each storage container will be clearly labeled with the following information: source material, concentration in Curies, and dose rate at 1 meter from the holder. Labels, warning signs, and alarms for source containers and the storage facility will follow that prescribed by the NRC. The storage facility and source containers will not be altered in any way, and both will be locked when unattended.

Each probe will be securely fixed to a stand or other similar structure where it will be cooled, cleaned, and inspected for damage. Repairs will be made when possible. If the probe cannot be repaired onsite, a note will be made of this on the tool checklist and the tool will be labeled "out of service" until repairs can be made.

The site will be checked for any debris, spills, or litter resulting from logging activities. All such matter will be removed and disposed of in accordance with regulations applicable to the site.

### **5.4 Cleaning and Decontamination**

## Geophysical Logging, Calibration, and Quality Control

(Includes Potential Radioactive Sites)

SOP 3-4

Revision: 7

Date: February 2015

All equipment brought onto the site shall be clean and free of leaking oil, grease, or hydraulic fluid. Equipment that may contact the interior of the borehole shall be cleaned and decontaminated in the designated decontamination area. Downhole equipment will be: (1) steam cleaned, (2) scrubbed with a brush and laboratory-grade detergent and water solution, and (3) rinsed with potable water before its use downhole and between holes. Some downhole geophysical probes may have restrictions pertaining to decontamination and will be decontaminated according to the manufacturer's specifications.

After cleaning and decontamination, all tools and equipment that may be used downhole must be kept clean and free of contaminants. Decontaminated equipment shall be kept off the ground by storing on clean racks and/or wrapping in plastic. All tools and equipment shall be cleaned and decontaminated as required to maintain an uncontaminated condition.

### 6.0 Restrictions/Limitations

Several hazards are associated with activities surrounding geophysical logging and these are outlined below:

#### 6.1 Mechanical Hazards

The use of machinery to lift and lower the probe in and out of the borehole may require the use of hoists, cables, winches, rigs, etc., that are under tension or compression. Breakage or malfunction of any one of these components could cause the release of uncontrollable forces that may in turn impart tremendous physical damage to personnel and other equipment.

Site personnel shall be aware of swinging probes (weighing up to 136 kilograms [kg] [300 pounds]), or other associated equipment, suspended in midair before entry or after exiting the borehole. Site personnel shall also guard against falling components from probes that have had joints loosened.

#### 6.2 Electrical Hazards

Hazards may arise from the use of several electrical power sources. Potential shocks may arise from improper handling of nongrounded power supplies or from probes using induced current electrodes or high voltage generators (120 to 600 V) used to power the tools. Lines from these power sources will be connected to ground fault circuit breakers.

All generators will be grounded. All extension cords from any power source will be composed of three conductor insulated wires and will be inspected for any frays, cuts, or other damage.

#### 6.3 Nuclear Hazards

Many geophysical logging programs rely on a suite of techniques that are collectively classified as nuclear logging. Some nuclear logging tools contain radioactive materials that serve as sources of radiation that are uniquely attenuated by the surrounding borehole matrix. Other nuclear logging tools measure ambient gamma radiation and do not use radioactive sources but require frequent calibration with radioactive materials. All permits will be kept in an open file in the logging vehicle. The use of nuclear tools needs to be preplanned and carefully thought out, monitored, and well supervised by highly trained individuals familiar with the particular logging technique and equipment. Active nuclear logging tools will be stored in shields specifically designed for each tool (passive tools do not need shielding). Monitoring equipment must be used at specified times in nuclear tool storage facilities and will be calibrated at specified intervals. Tags indicating the dates of monitor equipment calibration will be attached. Wipe test results and calibration records will be stored onsite in open files.

For the health and safety of the staff engaged in geophysical logging, all personnel working with the geophysical team will wear a Thermoluminescent Dosimeter (TLD) badge or a Radiation Exposure Film Badge as required by project, client, and/or site requirements. This badge must be worn on the top front outer garment. Exception to this rule is given to visitors and temporary assistants, who must at all times maintain a safe distance (determined by the site safety officer) between themselves and the radioactive source(s).

A radiation survey meter will be available, checked, and calibrated for operation before site transport. An up-to-date copy of the radiation survey and meter calibration will be kept on file in the logging vehicle.

The following briefly summarizes the radioactive materials used for each logging technique:

## Geophysical Logging, Calibration, and Quality Control

(Includes Potential Radioactive Sites)

SOP 3-4

Revision: 7

Date: February 2015

- Natural gamma logging measures the ambient gamma radiation of in situ, naturally occurring elements within the geological strata such as potassium, thorium, and uranium. Tools used to detect natural gamma radiation do not emit radiation but are calibrated with radioactive material. Calibration standards requiring a license for purchase, handling, and transport will be used only by licensed and trained individuals.
- Neutron logging requires the use of radioactive sources that emit high-energy neutrons within the logging probe, some of which also emit gamma radiation. Neutron concentrations for these probes range between a low of 10 millicuries (mCi) to a high of 5 Curies (Ci). Radioactive sources commonly used in a neutron probe are americium/beryllium mixtures. Older probes may have mixtures of beryllium and radium or beryllium and plutonium. Radium/beryllium probes have an added danger over those made of americium/beryllium in that they emit high doses of gamma radiation. Because neutron radiation is most effectively attenuated by hydrogen atoms, shields for neutron sources are composed of hydrogenous materials. Storage facilities will be monitored to assure all shields are effectively blocking neutron radiation.
- Gamma-gamma and density logs contain radioactive sources that emit gamma radiation. The radioactive source most commonly used is cesium-137, with older probes using cobalt-60 as a gamma radiation source.

### 7.0 References

American Society for Testing and Materials. 2010. *Standard Guide for Planning and Conducting Borehole Geophysical Logging (D5753-05 (Reapproved 2010): Annual Book of ASTM Standards*, 9

Keys, W. Scott. 1989. National Water Well Association. *Borehole Geophysics Applied to Ground-Water Investigations*.

U. S. Geological Survey. 2013. Quality-Assurance Plan for Groundwater Activities, U.S. Geological Survey, Washington Water Science Center. Open File Report 2013-1151

### 8.0 Attachments

Attachment 1 - Example Health and Safety Checklist

Attachment 2 - Example QA Geophysical Checklist for Borehole Logging

Attachment 3 - Example Geophysical Logging Tool Checklist

Attachment 4 - Example Log Heading

**Geophysical Logging, Calibration,  
and Quality Control**  
(Includes Potential Radioactive Sites)

SOP 3-4  
Revision: 7  
Date: February 2015

**Attachment 1**  
**Example Health And Safety Checklist**

Project Name/Contract Number \_\_\_\_\_

Well Name and Number \_\_\_\_\_ Location \_\_\_\_\_

Logging Company \_\_\_\_\_

Suite of Logs Run \_\_\_\_\_

Name of Recorder \_\_\_\_\_ Initials \_\_\_\_\_

Date and Time \_\_\_\_\_

**General Health and Safety Checklist**

| Yes | No |  |
|-----|----|--|
|     |    | All personnel working in the restricted area wearing TLD Badges or Radiation Exposure Film Badges as required?                 |
|     |    | Restricted area properly controlled, thus preventing any unauthorized entry?   |
|     |    | All radioactive sources are stored in a secured, labeled, and properly shielded location?                                      |
|     |    | A copy of the operating and emergency procedures has been reviewed by logging supervisor and is on file in the field office?   |
|     |    | Were there any incidents that required implementation of emergency procedures? If yes, were the emergency procedures followed? |
|     |    | Were storage facilities of radioactive sources posted with the proper labels?  |

**Geophysical Logging, Calibration,  
and Quality Control**  
(Includes Potential Radioactive Sites)

SOP 3-4  
Revision: 7  
Date: February 2015

**Attachment 2**  
**Example QA Geophysical Checklist For Borehole Logging**

Project Name/Contract Number \_\_\_\_\_

Well Name and Number \_\_\_\_\_ Location \_\_\_\_\_

Logging Subcontractor \_\_\_\_\_ Date \_\_\_\_\_

Total Borehole Depth \_\_\_\_\_ (feet) Well Depth \_\_\_\_\_ (feet) Logger \_\_\_\_\_ (feet)

Ground Elevation \_\_\_\_\_ (feet) Permanent Datum \_\_\_\_\_

Permanent Datum Elevation \_\_\_\_\_ (feet)

Suite of logs to be run: Sp \_\_\_\_\_ Temp \_\_\_\_\_ "16-64" Ris \_\_\_\_\_ SPRis \_\_\_\_\_ Ind \_\_\_\_\_  
Gam Ray \_\_\_\_\_ Gam Gam \_\_\_\_\_ Caliper \_\_\_\_\_ Other \_\_\_\_\_

Name of Operator: \_\_\_\_\_ Date: \_\_\_\_\_ Initials: \_\_\_\_\_

Name of Recorder: \_\_\_\_\_ Date: \_\_\_\_\_ Initials: \_\_\_\_\_

Monitor Well Construction Materials: Casing \_\_\_\_\_ Screen \_\_\_\_\_

Drilling/Construction Fluids: \_\_\_\_\_

**General Quality Assurance Checks**

| Yes | No |   |
|-----|----|---|
|     |    | Base map is located onsite.   |
|     |    | Before running the nuclear logging suite, borehole conditions were evaluated and considered suitable for such logs using information from caliper and previously run logs (e.g., depth, variations in diameter, lost circulation zones, casing, debris in hole, fluid type, and known contaminants) |
|     |    | Appropriate scales have been chosen using nearby, onsite well logs. These are available for a comparison to present log readings.   |
|     |    | Onsite tool calibrations have been performed using calibration checks implemented before and after each log run.  |
|     |    | Logging scales chosen for all logging tools are appropriate for borehole conditions and required sensitivity. Off-scale logs have been rerun using scale adjustments when the offending off-scale run cannot generate an on-scale plot.   |
|     |    | Were there scale changes while running a log? If yes, which logs? _____   |
|     |    | Scale changes, exceptional conditions, and other anomalies have been appropriately annotated on the affected logs.  |
|     |    | Depth control during log mergings have been checked.  |
|     |    | After Survey Depth Errors (ASDE) have been checked.   |
|     |    | Hard copies have been examined for several log runs and there is good correlation of well depth between them.   |
|     |    | All well log hard copies have been examined upon completion of the logging suite and good correlation exists between them.  |
|     |    | Borehole mud samples have been taken just before logging and mud resistivity measured.  |

## Geophysical Logging, Calibration, and Quality Control

(Includes Potential Radioactive Sites)

SOP 3-4

Revision: 7

Date: February 2015

### General Quality Assurance Checks (Cont.)

| Yes | No |   |
|-----|----|---|
|     |    | Optimal data acquisition has been achieved by choosing the most appropriate logging speed and time constant from test runs (when necessary) of varying speeds.  |
|     |    | Logging speeds for boreholes less than 2,000 feet have not exceeded 25 feet per minute. Some tools may require slower logging speeds.   |
|     |    | Field log headings are filled out as completely as possible. Final print log headings are completely filled out.  |
|     |    | The repeat length for a uniform section has not been less than 50 feet, a variable section not less than 200 feet. When possible, boreholes less than 1,000 feet have had the entire hole length repeated.  |
|     |    | If log quality appears questionable, attempts have been made to ascertain cause and make adjustments. If a satisfactory log cannot be obtained, note reason.  |
|     |    | The specific hardware brand and model number used for data acquisition has been recorded in the field logbook. All software used for data acquisition and retrieval has been recorded in the field logbook. |
|     |    | Tool manufacturer, model, and serial numbers have been noted. Tool configuration, diagrams, and manuals are available and located in the field (or logging) operation office.                               |
|     |    | Logging subcontractor has been questioned to determine whether any tools have been modified or deviate from factory specifications. Modifications have been noted on field log checklist.                   |
|     |    | CD ROMs have been made of the unedited, raw digital logging data and are stored in the field operation office.  |
|     |    | Processed, raw digital data that is in final form accompanies the final processing report.  |
|     |    | The final processing report has the necessary audit and audit process documentation.  |

**Geophysical Logging, Calibration,  
and Quality Control**  
(Includes Potential Radioactive Sites)

SOP 3-4  
Revision: 7  
Date: February 2015

**Attachment 3  
Example Geophysical Logging Tool Checklist**

| Temperature Log (This log shall be run first.)   |                                       |                       |
|--|---------------------------------------|-----------------------|
| Make   | Model                                 | Serial No.            |
| Modification (Yes/No)? (Describe fully on separate sheet and attach.)  |                                       |                       |
| Tool schematic and operating manual on file (Yes/No)   |                                       | Location of schematic |
| Order in which tool was run.   | Run in combination with (other tools) |                       |
| Logging Speed (m/min) (ft/min)   | Repeat Section Interval Location      |                       |
| <input type="checkbox"/> Tool logged in fluid-filled hole? (Yes/No)<br><input type="checkbox"/> Calibrated onsite (optional)? (Yes/No) If no, where calibrated and date of calibration?<br><input type="checkbox"/> Readings appear to be of good quality, no noise. (Yes/No) If noise exists, what is this attributed to? |                                       |                       |

| Spontaneous Potential (SP) Log  |                                       |                       |
|---|---------------------------------------|-----------------------|
| Make  | Model                                 | Serial No.            |
| Modification (Yes/No)? (Describe fully on separate sheet and attach.)   |                                       |                       |
| Tool schematic and operating manual on file (Yes/No)  |                                       | Location of schematic |
| Order in which tool was run.  | Run in combination with (other tools) |                       |
| Logging Speed (m/min) (ft/min)  | Repeat Section Interval Location      |                       |
| <input type="checkbox"/> Tool logged in fluid-filled hole? (Yes/No)<br><input type="checkbox"/> Calibration performed before logging? (Yes/No)<br><input type="checkbox"/> Calibration performed after logging? (Yes/No)<br><input type="checkbox"/> Calibration data printed and attached to log trace.<br><input type="checkbox"/> Sensitivity for conditions appropriate? Line has "character."<br>(Sensitivity sediment and fluid conditions may cause lack of character.)<br><input type="checkbox"/> No excessive SP baseline drift.<br><input type="checkbox"/> Baseline shifts (if necessary) annotated on log.<br><input type="checkbox"/> Resistivity of borehole fluid taken and recorded on log.<br><input type="checkbox"/> Resistivity of interstitial water taken and recorded on log. |                                       |                       |

Project Name/Contract Number \_\_\_\_\_ Date \_\_\_\_\_

**Geophysical Logging, Calibration,  
and Quality Control**  
(Includes Potential Radioactive Sites)

SOP 3-4  
Revision: 7  
Date: February 2015

Logging Subcontractor \_\_\_\_\_ Geophysical Logging Engineer \_\_\_\_\_ Well \_\_\_\_\_ Location \_\_\_\_\_

(Initial to certify this page)

**Attachment 3**  
**Example Geophysical Logging Tool Checklist (Cont.)**

| Caliper (i.e., 1 arm, 3 arm?) Log  |                                       |  |
|--|---------------------------------------|--|
| Make   | Model                                 | Serial No.                                     |
| Modification (Yes/No)?   |                                       | (Describe fully on separate sheet and attach.) |
| Tool schematic and operating manual on file (Yes/No)   |                                       | Location of schematic                          |
| Order in which tool was run.   | Run in combination with (other tools) |  |
| Logging Speed (m/min) (ft/min)   | Repeat Section Interval Location      |  |
| <input type="checkbox"/> Calibration check performed<br><input type="checkbox"/> Caliper reading checked in casing, if casing is present<br><input type="checkbox"/> Repeat section logged or second run performed |                                       |  |

| Gamma-Gamma (Density) Log  |                                       |  |
|--|---------------------------------------|--|
| Make   | Model                                 | Serial No.                                     |
| Modification (Yes/No)?   |                                       | (Describe fully on separate sheet and attach.) |
| Tool schematic and operating manual on file (Yes/No)   |                                       | Location of schematic                          |
| Order in which tool was run.   | Run in combination with (other tools) |  |
| Logging Speed (m/min) (ft/min)   | Repeat Section Interval Location      |  |
| <input type="checkbox"/> Hole condition good, checked by previous log runs (do not run nuclear tools under questionable hole conditions)<br><input type="checkbox"/> Tool logged in fluid-filled or air-filled (circle one), uncased or cased (circle one) hole<br><input type="checkbox"/> Radiation survey conducted in immediate vicinity of drill site before unshielding source<br><input type="checkbox"/> Radiation survey conducted in immediate vicinity of drill site after last nuclear source is shielded and logging job is finished<br><input type="checkbox"/> Calibration performed before logging<br><input type="checkbox"/> Calibration performed after logging<br><input type="checkbox"/> Calibration data printed and attached to log trace<br><input type="checkbox"/> Log checked for anomalous spikes, drift, and cyclic readings<br><input type="checkbox"/> Compare density log to caliper log; density shall show a variant reading in area of washouts<br><input type="checkbox"/> With probe sitting still, statistical variation shall be on the order of the square root of the count rate |                                       |  |

Project Name/Contract Number \_\_\_\_\_ Date \_\_\_\_\_



**Geophysical Logging, Calibration,  
and Quality Control**  
(Includes Potential Radioactive Sites)

SOP 3-4  
Revision: 7  
Date: February 2015

Logging Subcontractor \_\_\_\_\_ Geophysical Logging Engineer \_\_\_\_\_ Well \_\_\_\_\_ Location \_\_\_\_\_

(Initial to certify this page)

**Attachment 3**  
**Example Geophysical Logging Tool Checklist (Cont.)**

|  |                                       |  |  |
|--|---------------------------------------|--|--|
| <b>Normal Resistivity</b>  |                                       | Spacing between electrodes (inches)            |  |
| Make   | Model                                 | Serial No.                                     |  |
| Modification (Yes/No)?   |                                       | (Describe fully on separate sheet and attach.) |  |
| Tool schematic and operating manual on file (Yes/No)   |                                       | Location of schematic                          |  |
| Order in which tool was run.   | Run in combination with (other tools) |  |  |
| Logging Speed (m/min) (ft/min)   | Repeat Section Interval Location      |  |  |
| <input type="checkbox"/> Tool logged in fluid-filled hole, uncased hole<br><input type="checkbox"/> Calibration performed before logging<br><input type="checkbox"/> Calibration performed after logging<br><input type="checkbox"/> Calibration data printed and attached to log trace<br><input type="checkbox"/> Curve is stable, with no abnormal looking excursions |                                       |  |  |

|  |                                       |  |  |
|--|---------------------------------------|--|--|
| <b>Single Point Resistance</b>   |                                       |  |  |
| Make   | Model                                 | Serial No.                                     |  |
| Modification (Yes/No)?   |                                       | (Describe fully on separate sheet and attach.) |  |
| Tool schematic and operating manual on file (Yes/No)   |                                       | Location of schematic                          |  |
| Order in which tool was run.   | Run in combination with (other tools) |  |  |
| Logging Speed (m/min) (ft/min)   | Repeat Section Interval Location      |  |  |
| <input type="checkbox"/> Tool logged in fluid-filled, uncased hole<br><input type="checkbox"/> Calibration performed before logging<br><input type="checkbox"/> Calibration performed after logging<br><input type="checkbox"/> Calibration data printed and attached to log trace<br><input type="checkbox"/> Resistance greater than cable line resistance<br><input type="checkbox"/> Scale reads in ohms<br><input type="checkbox"/> Check for sharp deflections of consistent amplitude and frequency caused by mechanical problems<br><input type="checkbox"/> Compare to caliper log. Is log greatly affected by change in borehole diameter? |                                       |  |  |

Project Name/Contract Number \_\_\_\_\_ Date \_\_\_\_\_

**Geophysical Logging, Calibration,  
and Quality Control**  
(Includes Potential Radioactive Sites)

SOP 3-4  
Revision: 7  
Date: February 2015

Logging Subcontractor \_\_\_\_\_ Geophysical Logging Engineer \_\_\_\_\_ Well \_\_\_\_\_ Location \_\_\_\_\_

(Initial to certify this page)

**Attachment 3  
Example Geophysical Logging Tool Checklist (Cont.)**

|  |                                       |  |  |
|--|---------------------------------------|--|--|
| Induction  |                                       | Spacing between electrodes (inches)            |  |
| Make   | Model                                 | Serial No.                                     |  |
| Modification (Yes/No)?   |                                       | (Describe fully on separate sheet and attach.) |  |
| Tool schematic and operating manual on file (Yes/No)   |                                       | Location of schematic                          |  |
| Order in which tool was run.   | Run in combination with (other tools) |  |  |
| Logging Speed (m/min) (ft/min)   | Repeat Section Interval Location      |  |  |
| <input type="checkbox"/> Tool logged in fluid-filled or air-filled (circle one), uncased hole<br><input type="checkbox"/> Calibration performed before logging<br><input type="checkbox"/> Calibration performed after logging<br><input type="checkbox"/> Calibration data printed and attached to log trace<br><input type="checkbox"/> Check for negative resistivity readings for indication of improper calibration<br><input type="checkbox"/> Check for similarity to 16" normal resistivity curve, for single curve, shallow investigation induction log<br><input type="checkbox"/> Repeat section logged |                                       |  |  |

|   |                                       |  |  |
|---|---------------------------------------|--|--|
| <b>Natural Gamma (Gamma Ray) Log</b>  |                                       |  |  |
| Make  | Model                                 | Serial No.                                     |  |
| Modification (Yes/No)?  |                                       | (Describe fully on separate sheet and attach.) |  |
| Tool schematic and operating manual on file (Yes/No)  |                                       | Location of schematic                          |  |
| Order in which tool was run.  | Run in combination with (other tools) |  |  |
| Logging Speed (m/min) (ft/min)  | Repeat Section Interval Location      |  |  |
| <input type="checkbox"/> Tool logged in fluid-filled or air-filled (circle one), uncased or cased (circle one)<br><input type="checkbox"/> Radiation survey conducted in immediate vicinity of drill site before unshielding source<br><input type="checkbox"/> Radiation survey conducted in immediate vicinity of drill site after last nuclear source is shielded after job is finished<br><input type="checkbox"/> Hole condition is shielded after job is finished<br><input type="checkbox"/> Hole condition good, checked by previous log runs; do not run nuclear tools under questionable hole conditions<br><input type="checkbox"/> Tool run in fluid-filled or air-filled (circle one), uncased or cased (circle one)<br><input type="checkbox"/> Calibration performed before logging<br><input type="checkbox"/> Calibration performed after logging<br><input type="checkbox"/> Calibration data printed and attached to log trace<br><input type="checkbox"/> Check for cyclic noise<br><input type="checkbox"/> Repeat section logging |                                       |  |  |

Project Name/Contract Number \_\_\_\_\_ Date \_\_\_\_\_

**Geophysical Logging, Calibration,  
and Quality Control**  
(Includes Potential Radioactive Sites)

SOP 3-4  
Revision: 7  
Date: February 2015

Logging Subcontractor \_\_\_\_\_ Geophysical Logging Engineer \_\_\_\_\_ Well \_\_\_\_\_ Location \_\_\_\_\_

(Initial to certify this page)

**Attachment 3**  
**Example Geophysical Logging Tool Checklist (Cont.)**

|  |                                       |  |  |
|--|---------------------------------------|--|--|
| <b>Neutron</b>   |                                       | Spacing between electrodes (inches)            |  |
| Make   | Model                                 | Serial No.                                     |  |
| Modification (Yes/No)?   |                                       | (Describe fully on separate sheet and attach.) |  |
| Tool schematic and operating manual on file (Yes/No)   |                                       | Location of schematic                          |  |
| Order in which tool was run.   | Run in combination with (other tools) |  |  |
| Logging Speed (m/min) (ft/min)   | Repeat Section Interval Location      |  |  |
| <input type="checkbox"/> Hole condition good, checked by previous log runs (do not run nuclear tools under questionable hole conditions)<br><input type="checkbox"/> Tool logged in fluid-filled or air-filled (circle one), uncased or cased (circle one) hole<br><input type="checkbox"/> Radiation survey conducted in immediate vicinity of drill site before unshielding source<br><input type="checkbox"/> Radiation survey conducted in immediate vicinity of drill site after last nuclear source is shielded after logging job is finished<br><input type="checkbox"/> Calibration performed before logging<br><input type="checkbox"/> Calibration performed after logging<br><input type="checkbox"/> Calibration data printed and attached to log trace<br><input type="checkbox"/> Check log for adequate sensitivity<br><input type="checkbox"/> Check log for anomalous spikes, drifts, and cyclic readings<br><input type="checkbox"/> Repeat section logged |                                       |  |  |

|  |                                       |  |  |
|--|---------------------------------------|--|--|
| <b>Acoustic Logs</b>   |                                       |  |  |
| Make   | Model                                 | Serial No.                                     |  |
| Modification (Yes/No)?   |                                       | (Describe fully on separate sheet and attach.) |  |
| Tool schematic and operating manual on file (Yes/No)   |                                       | Location of schematic                          |  |
| Order in which tool was run.   | Run in combination with (other tools) |  |  |
| Logging Speed (m/min) (ft/min)   | Repeat Section Interval Location      |  |  |
| <input type="checkbox"/> Tool logged in fluid-filled, uncased hole (yes/no). If no, explain.<br><input type="checkbox"/> Calibration not required; check tool for function by listening for transmitter clicking; may calibrate tool in fluid-filled surface casing if present<br><input type="checkbox"/> Tool centralized<br><input type="checkbox"/> Log checked for noise spikes, cycle skipping, or other anomalies<br><input type="checkbox"/> Repeat section logged |                                       |  |  |

Project Name/Contract Number \_\_\_\_\_ Date \_\_\_\_\_

**Geophysical Logging, Calibration,  
and Quality Control**  
(Includes Potential Radioactive Sites)

SOP 3-4  
Revision: 7  
Date: February 2015

Logging Subcontractor \_\_\_\_\_ Geophysical Logging Engineer \_\_\_\_\_ Well \_\_\_\_\_ Location \_\_\_\_\_

(Initial to certify this page)

**Attachment 4**  
**Example Log Heading**

|                                |      |            |  |   |    |
|--------------------------------|------|------------|--|---|----|
| Logging Subcontractor:         |      |            | Log Technique:                               |   |    |
| Address:                       |      |            | Date:  |   |    |
| Logging Operator:              |      |            |  |   |    |
| Drilling Subcontractor:        |      |            |  |   |    |
| Client:                        |      |            |  |   |    |
| Well:                          |      |            |  |   |    |
| Location:                      |      |            |  |   |    |
| State:                         |      |            | Ground Elevation (m) (ft):<br>Log Depth Ref: |   |    |
| Borehole Data                  |      |            |  |   |    |
| Logging Depth:                 |      |            |  |   |    |
| Customer Measurement (m) (ft): |      |            | Logging Subcontractor Measurement (m) (ft):  |   |    |
| Bit Record                     |      |            | Casing Record                                |   |    |
| Size                           | From | To         | Size/Wgt/TLK                                 | From  | To |
|                                |      |            |  |   |    |
|                                |      |            |  |   |    |
|                                |      |            |  |   |    |
|                                |      |            |  |   |    |
| Hole Medium:                   |      |            | Drilling Method:                             |   |    |
| Borehole Mud:                  |      |            | Circulation Time:                            |   |    |
| Weight:                        |      | Viscosity: |  | Restrictions:<br>mud formation<br>at Temperature: |    |

Project Name/Contract Number \_\_\_\_\_ Date \_\_\_\_\_

**Geophysical Logging, Calibration,  
and Quality Control**  
(Includes Potential Radioactive Sites)

SOP 3-4  
Revision: 7  
Date: February 2015

Logging Subcontractor \_\_\_\_\_ Geophysical Logging Engineer \_\_\_\_\_ Well \_\_\_\_\_ Location \_\_\_\_\_

(Initial to certify this page)

**Attachment 4  
Example Log Heading (Cont.)**

| Logging Data |         |           |           |             |                |                       |
|--------------|---------|-----------|-----------|-------------|----------------|-----------------------|
| Log Function | Run No. | Equipment |           |             | Logging        |                       |
|              |         | Model     | Probe No. | Uphole S.N. | Dig Int (m/ft) | Speed (m/min)(ft/min) |
|              |         |           |           |             |                |                       |

| Logging Data |              |       |        |              |                 |    |             |
|--------------|--------------|-------|--------|--------------|-----------------|----|-------------|
| Detect OR    | Spacing      |       | Source |              | Logged Interval |    |             |
| Type         | Tx-Rx (m/ft) | Rx-Rx | Type   | Curie Amount | From            | To | Int. (m/ft) |
|              |              |       |        |              |                 |    |             |

Project Name/Contract Number \_\_\_\_\_ Date \_\_\_\_\_

Logging Subcontractor \_\_\_\_\_ Geophysical Logging Engineer \_\_\_\_\_ Well \_\_\_\_\_ Location \_\_\_\_\_

(Initial to certify this page)

**Geophysical Logging, Calibration,  
and Quality Control**  
(Includes Potential Radioactive Sites)

SOP 3-4  
Revision: 7  
Date: February 2015

**Lithologic Logging**

SOP 3-5

Revision: 9

Date: February 2015

Approved:

  
Signature

Technical Review:

David Schroeder

**1.0 Objective**

This technical standard operating procedure (SOP) governs lithologic logging of core, cuttings, split-spoon samples, and subsurface samples collected during field operations at sites where environmental investigations are performed. The purpose of this SOP is to present a set of descriptive protocols and standardized reporting formats to be used in making lithologic observations. It prescribes protocols for recording basic lithologic data including, but not limited to, lithologic names, texture, composition, color, sedimentary structures, bedding, lateral and vertical contacts, and secondary features such as fractures and bioturbation.

The goal of this SOP is to provide a set of instructions to produce uniform lithologic descriptions and to present a list of references to help in this task.

**2.0 Background****2.1 Definitions**

The following list of definitions corresponds to the description sequences outlined in Section 5.2.1. They are provided to aid the geologist in what to look for when following the sequences. Example lithologic logs are given in Attachment A.

**Name of Sediment or Rock** - In naming unconsolidated sediments, the logger shall use field equipment and reference charts to help identify the grain-size distribution and shall name the material according to the procedure in Section 5.2.1. In naming sedimentary, igneous, and metamorphic rocks, the logger shall examine the specimen for mineralogy and use the appropriate classification chart in the attachments.

**Texture** - In examining unconsolidated sediments, the texture shall refer to the grain-size distribution, particle angularity, sorting, and packing. The logger shall provide estimates of the grain sizes present using Attachment B and C. When larger particles such as cobbles are present, determine the size of the particles and give a percentage estimate. The sediment particles shall be examined for angularity by comparing with Attachment B and the sorting shall be determined by percentage estimation. The logger shall note that the Unified Soil Classification System (USCS) uses the term grading to describe how the materials are sorted. (A poorly sorted unconsolidated material is well graded.) In examining igneous rocks, texture refers to whether the specimen is aphanitic, phaneritic, glassy, fragmental, porphyritic, or pegmatitic. Attachment D has more specific definitions of these terms. For metamorphic rocks, texture refers to whether the specimen has a foliated structure (slaty, phyllitic, schistose, or gneissic) or nonfoliated structure (granular).

**Color** - Color may be determined using the appropriate Munsell color chart (soil or rock) and listing the Munsell number that corresponds to the color. If an unconsolidated material is mottled in color, the ranges in color shall be described. When describing core samples with several individual colors such as in phaneritic textures, individual color names shall be listed, and an overall best color name shall be given.

**Sedimentary Structures** - This term refers primarily to unconsolidated sediments and sedimentary rocks. There are several different sedimentary structures, and the logger is referred to Compton's *Manual of Field Geology* (1962) book for more details. Among the more common structures are bedding, cross-bedding, laminations, and burrows. These structures shall only be included in the description if found in the samples.

**Degree of Consolidation** - The degree of consolidation is applicable to sedimentary rocks and unconsolidated sediments and refers to how well the material has been indurated. Unconsolidated sediments may be compacted somewhat and shall be described as loose, moderately compacted, or strongly compacted. In some cases they may be slightly cemented by caliche and shall be described as slightly cemented, moderately cemented, or strongly cemented. Sedimentary rocks are typically indurated but may vary in the degree of cementation. These materials shall be described as friable, moderately friable, or well indurated. When describing the cementing material, a test for reaction to hydrochloric acid (HCl) shall be done and results recorded under the description. If the logger believes he/she can identify the cementing material, then it shall be included in the description.

## Lithologic Logging

SOP 3-5

Revision: 9

Date: February 2015

**Moisture Content** - Moisture content refers to the amount of water within the sediment or the matrix. Typically sedimentary rocks and unconsolidated sediments may have water within and shall be described as dry, moist, wet (not flowing), or saturated (flowing water). Igneous and metamorphic rocks may have water within fractures and cavities. The presence of water and pertinent observations that may help in site evaluation in these rocks shall be noted.

**Presence of Fractures, Cavities, and Secondary Mineralization** - The rock that may be encountered during drilling may have fractures or joints present within them. Should fractures be observed, they shall be noted and a description as to the density of fractures shall be given. Cavities or vugs may be present, and the density of voids, as well as size estimation, shall be given. If fractures or cavities contain evidence of secondary minerals such as zeolites, clays, or iron oxides, then a description of the mineral fill shall be added.

**Evidence of Contamination** - The logger shall examine the core and note any obvious signs of contamination such as streaking, free product, odor, or discoloration. These observations shall be noted in the field book as shall any readings from the photoionization or flame ionization detector (PID/FID). PID/FID hits shall be recorded on the Lithologic Log Form also.

**Description of Contacts** - The logger shall note any significant change in lithology. These changes may be gradational contacts within sediments or may be sharp contacts such as sediments over rocks. The contacts shall be noted as to whether they are erosional, gradational, or sharp, and the depth below the surface shall be noted.

**Composition** - The composition of the rock refers to the mineralogy of the material encountered. For sedimentary rocks, it is important to note the matrix composition and use Attachment E in naming. In igneous and metamorphic rocks, the minerals that make up the rock shall be stated and an estimation of their percentage shall be noted. The classification charts listed in Attachments D and F provide a description of common compositions.

### 2.2 Associated Procedures

- SOP 4-1, *Field Logbook Content and Control*

### 2.3 Discussion

The installation of monitoring wells, piezometers, and boreholes is a standard practice at many sites requiring environmental investigations. The installation of these devices requires that a trained geologist, or other earth scientist under a geologist's supervision, provide lithologic descriptions as they encounter subsurface material during auguring or drilling. In evaluating these lithologic descriptions from different boreholes, monitoring wells, or piezometers, it is sometimes possible to correlate similar units. To help in this task, it is important to provide uniform and consistent descriptions.

In describing lithologies, it is helpful to have a set of references covering items such as the classification of igneous, metamorphic, and sedimentary rocks; grain-size percentage estimation; particle shape; grain-size charts; and lithologic symbols. To make lithologic descriptions produced by CDM Smith staff as uniform and consistent as possible, this SOP provides a list of references to be used in the field. This SOP also provides a sequence for recording information on a standardized log form to make descriptions as uniform and consistent as possible.

### 3.0 General Responsibilities

**Geologist** - The field person performing lithologic logging is responsible for making a consistent and uniform log and for turning in field forms and logbooks to the field team leader (FTL).

**Field Team Leader (FTL)** - The FTL is responsible for maintaining logbooks and forms and for approving techniques of lithologic logging not specifically described in this SOP.

**Note:** Responsibilities may vary from site to site. Therefore, all field team member responsibilities shall be defined in the field plan or site/project specific quality assurance plan.



**Lithologic Logging**

SOP 3-5

Revision: 9

Date: February 2015

**4.0 Required Equipment**

The description of subsurface lithologies requires a minor amount of field equipment for the geologist. This section provides a list of equipment to be used by the lithologic logger but does not include equipment such as drill rigs, PID/FID, sampling equipment, and personal protection equipment. The following is a general list of equipment that may be used:

- Field logbook and Lithologic Log Form
- Clipboard
- Dilute (10 percent) HCl
- Plastic sheeting
- PVC sampling trays
- Waterproof pens
- No. 2 sieve
- 10x magnifying hand lens
- Reference field charts
- Engineers tape measure or folding stick

**5.0 Procedures****5.1 Office**

- Obtain field logbook and Lithologic Log Forms
- Coordinate schedules/actions with FTL
- Obtain necessary field equipment (i.e., hand lens, 10 percent HCl)
- Obtain CDM Smith reference field charts
- Review field support documents (i.e., sampling plan, health and safety plan)
- Review applicable geologic references such as U.S. Department of Agriculture (USDA) Soil Conservation Survey Soil Surveys and/or geologic maps

**5.1.1 Documentation**

Individuals performing lithologic logging will record their observations in a commercially available, bound field logbook (e.g., Lietz books) and/or on individual Lithologic Log Forms. Lithologic loggers will follow the general procedures for keeping a field logbook (SOP 4-1). When using a bound field logbook, record the same data required on the Lithologic Log Form. Data from the field logbook must be transcribed to the Lithologic Log Form if filling in the form in the field is not feasible. However, the data must be the same as that recorded in the field logbook. Editing of field logbook data is not allowed. In addition, if data are transcribed to the Lithologic Log Form, it shall be done within 1 day of the original data recording. All blanks in the Lithologic Log Form must be filled out. If an item is not applicable, an "NA" shall be entered. Note that the Lithologic Log may be modified based on the type of drilling (i.e., changing the blow count column to rock quality designation (RQD) for rock coring).

The Lithologic Log Form shall be filled out according to the following instructions:

The front page of the form contains general information:

- The project name, location, and description
- Borehole number
- Date that the drilling activity was started and completed
- Name of the person logging the well shall be recorded along with the total depth drilled
- Borehole diameter(s) and drilling methods shall be recorded
- Name and company of the driller and the type of drill rig and bits used

A map showing the drilling location may be attached.

The continuation page(s) shall be completed according to the instructions provided within this section and according to the sequence provided in Section 5.2.1. The depth column refers to the depth below ground surface and shall be provided in feet. The tick marks can be arbitrarily set to any depth interval depending on the scale needed except where client requirements dictate the spacing. The lithology column shall contain a schematic representation of the subsurface according to the symbols found in Attachment G. Use a single X to mark the area where no core was recovered, and notes shall be recorded as to why the section was not recovered. The X shall

**Lithologic Logging**

SOP 3-5

Revision: 9

Date: February 2015

be marked from the top to the bottom of the section so that the entire interval is marked. If the geologist can interpret the probable lithology of the missing section with reasonable confidence, they may fill in the symbols behind the X. Sharp or abrupt contacts between lithologies will be indicated by a solid horizontal line. Gradational changes in lithologic composition will be shown by a gradual change of lithologic symbol in the appropriate zone. PID/FID hits shall be recorded within the PID/FID column at the appropriate depth, if applicable. Blow counts specifically refer to the number of hammer blows it takes to drive a split-spoon into the ground. Usually this is recorded as the number of blows per 6 inches but may vary. The recording of blow counts provides a relative feel for the cohesiveness of the formation. The individual recording lithologic logs shall ask the FTL whether it is required information. The description column is the most important part of the Lithologic Log Form and is where the lithology is described. In completing this section, use the applicable reference charts and complete according to the sequence in Section 5.2.1. The sample interval column is reserved for noting any samples taken and processed for the laboratory. The sample number shall be filled in at the appropriate depth. The last column refers to the percent core recovery. The individual performing lithologic logging shall determine the amount recovered and write the percentage at the appropriate depth.

In addition to the information on the lithologic form, the logger shall record the appropriate information into the logbook when there is a rig shutdown, rig problems, failures to recover cores, or other issues.

## 5.2 General Guidelines for Using and Supplementing Lithologic Descriptive Protocols

This SOP is intended to serve as a guide for recording basic lithologic information with emphasis on those sediment or rock properties that affect groundwater flow and contaminant transport. The fields of specialization of geologists using this SOP will vary. If the user has expertise in a particular field of petrology or soil science that allows for descriptions of certain geologic sections beyond the basic level required by this SOP, they may expand their descriptions. This shall be done only with approval of the FTL. The descriptive protocol presented here must be followed in making basic observations. Any further descriptions must follow a protocol that is published and generally recognized by the geologic community as a standard reference.

General lithologic description will not include collecting detailed information such as can be obtained from sieve analysis or petrographic analysis. This SOP is a guide for recording visual observations of samples in the field aided by a 10x hand lens and the other simple tools. Field descriptions shall be supplemented by petrographic analysis and sieve analysis when the FTL needs data on numerical grain-size distributions, secondary porosity development, or other data that can be collected by these methods.

Description detail will also be dependent on the drilling and sampling methods used. Descriptions of drill cuttings will generally be very basic versus detailed descriptions of soil split-spoon or rock core samples.

This SOP includes protocols for describing igneous, metamorphic, bedrock, sedimentary rocks, and unconsolidated materials. Common abbreviations used for lithologic logging purposes are given in Attachment H. This SOP includes charts to be used for classification and naming of rocks, sediments, and soils and descriptions of texture, sedimentary structures, and percentage composition of grains. There is also a chart of lithologic symbols to be used and a list of abbreviations. For charts covering other observations or field procedures not specified by this SOP, the user is referred to the following for more information:

- *Compton's Manual of Field Geology and American Geological Society (AGI) Data Sheets for Geology in the Field, Laboratory, and Office* contain other reference charts applicable to descriptions. The source of the chart used must be recorded on the Lithologic Log Form or in the field logbook.
- The Munsell soil color chart may be used for descriptions of color.
- The *Dictionary of Geological Terms* (AGI) is to be used for definitions of geological terms.

Some observations will be common to all rock and soil descriptions. All descriptions shall include as appropriate: name of sediment or rock, color, sedimentary structures, texture, moisture content, composition, fabric, significant inclusions, and degree of consolidation or induration. The description of each category shall be separated by a semicolon. Each section that discusses descriptions of a particular lithology provides a sequence for recording observations. Follow these sequences for all descriptions. All interpretive comments shall be segregated from lithologic descriptions by recording them in the remarks column.

**Lithologic Logging**

SOP 3-5

Revision: 9

Date: February 2015

Secondary features affecting porosity and permeability such as fractures (joints or faults), cavities, and/or bioturbation shall be described if observed. Exact measurement of apparent bed thicknesses shall be made when logging core and shall supplement terminology such as “thin” or “thick.” Particular attention is to be given to recording exact locations of water tables, perched saturated zones, and description of contaminants that may be visible.

In some cases individuals logging may wish to describe materials such as unconsolidated sediments and soils according to different systems such as the USCS or USDA Soil Taxonomy System. These descriptions can provide additional information from what is required by this SOP. If an individual is competent in using other description methods, then they shall do so with permission from the FTL.

It is often more practical to use abbreviations for often repeated terminology when recording lithologic descriptions. For the terms given in this SOP, its attachments, or the associated charts to be used for description in the field, use only the designated abbreviations. Other abbreviations are allowed; however, the abbreviation and its meaning shall be recorded on the lithologic log the first time it is used and shall be recorded at least once for every well or boring log. Loggers are cautioned to limit the use of abbreviations to avoid producing a lithologic log that is excessively cryptic.

**5.2.1 Protocols for Lithologic Description of Discrete Soil or Rock Cores**

This section describes the protocols for completing a lithologic description based on discrete soil or rock core samples. The logger shall use the appropriate portion of this section when describing cores. In recording descriptions of sedimentary sections from a whole core, it is possible to reduce the amount of description being written by at least two strategies. One is to look at as long of a section of core as possible, looking for the “big” picture. For instance, in a 20-foot-thick zone, the dominant lithology may be siltstone that is interrupted by several thin beds of another lithology such as gravel. This section description can be simplified by writing: 35-55 below ground surface (bgs) = siltstone (with other descriptors) except as noted; 37.5-38.5 gravel zone (with descriptors); 40-42 pebble zone (with descriptors); etc. This also aids in “seeing” the thickest unit designations possible for use in modeling. Another acceptable way to describe the same interval would be: 35-37.5 siltstone; 37.5-38.5 gravel zone (with descriptors); 38-40 same as 35-37.5; 40-42 pebble zone (with descriptors); etc.

**Description of Unconsolidated Material**

Unconsolidated material comprises a significant portion of the sections of interest at CDM Smith sites. The shallow subsurface is very important to the hydrologic investigation, as this is the portion of the geologic section where infiltration first occurs. Much of the contamination at sites being investigated is surface contamination and therefore lies on, or within, the upper portion of the surficial material.

For the purpose of this SOP, soil refers to the upper biochemically weathered portion of the regolith and not the entire regolith itself. Soils are to be described as unconsolidated material and shall use the same description format. The scientist shall use the USCS classification if consistent with project objectives (Attachment K). More detailed soil descriptions shall only be made in addition to descriptions outlined below.

**Descriptions of unconsolidated sediments shall follow the following sequence:**

- Name of sediment (sand, silt, clay, etc.)
- Texture
- Composition of larger-grained sediments
- Color
- Structure
- Degree of consolidation and cementation
- Moisture content
- Evidence of bioturbation
- Description of contacts

**Lithologic Logging**

SOP 3-5

Revision: 9

Date: February 2015

In naming unconsolidated material (refer to Attachment I - Naming of Unconsolidated Materials), the particle size with the highest percentage is the root name. When additional grains are present in excess of 15 percent, the root name is modified by adding a term in front of the root name. For instance, if a material is 80 percent sand and 20 percent gravel, then it is gravelly sand. If the subordinate grains comprise less than 15 percent but greater than 5 percent, the name is written:

\_\_\_\_\_ (dominant grain) with \_\_\_\_\_ (subordinate grain). For example, a sediment with 90 percent sand and 10 percent silt would be named a sand with silt. If a sediment contains greater than 15 percent of four particle sizes, then the name is comprised of the dominant grain size as the root name and modifiers as added before. For example, if a material is 60 percent sand, 20 percent silt, and 20 percent clay the name would be a silty clayey sand. If a material is 70 percent sand, 20 percent silt, and 10 percent clay, it would be a silty sand with clay. When large cobbles or boulders are present, their percentage shall be estimated and their mineralogy recorded. Use AGI Data Sheet 29.1 (Attachment B) for grain terms. Refer to Attachment J for an example sorting chart.

**Description of Bedrock Material**

Descriptions of rock core can vary in detail depending on the experience of the geologist and the scope of the project. However, features that shall be noted while logging rock core include depth of major fractures, mineralization in fractures and cavities, degree of weathering, hardness, and RQD. The RQD is a ratio of the total length of intact rock 4 inches in length or longer to the length of the core run. The RQD provides a numeric indication of the degree of fracturing and weathering, and thereby, and indication of conductive zones and preferential contaminant migration pathways.

**Description of Sedimentary Rocks**

Sedimentary rocks consist of lithified detrital sediments such as sand and clay, chemically precipitated sediments such as limestone and gypsum, and biogenic material such as coal and coquina. The classification scheme for naming these rocks is found in Attachment E - Classification of Sedimentary Rocks.

**Descriptions for sedimentary rocks shall be given in the lithologic log in the following sequence:**

- Name of rock
- Texture
- Color
- Bedding
- Sedimentary structures
- Degree of composition
- Presence of fractures or vugs
- Bioturbation
- Description of contacts

**Description of Igneous and Metamorphic Rocks**

Igneous and metamorphic rocks are not as commonly observed at work sites, but they may be found interspersed in the sedimentary section as ash layers and as bedrock. Where they form bedrock, the development of fractures and vugs is important to their hydrologic properties. If the logger is unsure of the name of the rock because of difficulty in determining mineralogy, the name shall be accompanied by a question mark. Attachments D and F provide a classification system for these materials.

**Igneous and metamorphic rock descriptions shall follow the general format:**

- Name of rock
- Texture
- Color
- Degree of induration for volcanics
- Composition
- Presence of fractures or vugs
- Presence of secondary mineralization
- Foliation

**5.2.2 Protocols for Lithologic Description from Drill Cuttings**

The majority of boreholes drilled in bedrock are drilled without sampling or coring. This section describes the protocols that may be used for completing lithologic logs when discrete soil samples or rock cores are not collected. Lithologic logging of boreholes drilled without sampling generally requires a higher level of experience from the geologist as interpretations need to be made based on a number of factors that are usually not taken into account when logging from discrete samples. Certain details recorded on lithologic logs based on discrete sampling will not be seen (such as sedimentary structures) and therefore cannot be recorded from drill cuttings. Below are general guidelines that shall be used while filling out boring logs based on drill cuttings:

**Lithologic Logging**

SOP 3-5

Revision: 9

Date: February 2015

**Auger Drilling**

The following are general guidelines that can be used to describe cuttings from auger drilling:

- Collect cuttings for descriptions at least every 5 feet or if a change in the cuttings is noticed.
- Keep in mind travel time for cuttings to reach the surface when estimating the depth from which the cuttings originated.
- Pay attention to the reaction of the drill rig as different lithologies are encountered such as chattering versus smooth drilling, rapid easy auger advancement versus slow hard drilling, and auger refusal.
- Watch for the occurrence of water.

**Bedrock Rotary Drilling (including air hammer, air rotary, and mud rotary)**

The following are general guidelines that shall be used during rotary drilling:

- Use a strainer to collect cuttings at intervals of at least 10 feet or changes in lithology.
- Wash the cuttings in the strainer with potable water and examine for lithology.
- Note size of rock chips.
- Note changes in drill rig responses such as increasing or slowing drilling rate, sudden drop of the drill stem, increase in chatter and record in the remarks column of the lithologic log. These are usually good indicators of changes in lithology and/or fractures.
- If drilling with air, look for changes in color and reduction or disappearance of dust as an indicator of a lithology change and/or presence of water.
- If drilling with mud/fluid rotary, watch for gain or loss of water as an indicator of conductive zones.
- Record drilling rates as feet/minute, or as start and end times of each drill rod, in the remarks column of the boring log.

**6.0 Restrictions/Limitations**

Only geologists, or similarly qualified persons trained in lithologic description, are qualified to perform the duties described in this SOP. The FTL for a project will have the authority to decide whether or not an individual is qualified.

**7.0 References**

American Geological Society. 1989. *American Geological Society Data Sheets for Geology in the Field, Laboratory, and Office*, 3rd Ed.

Compton, R.R. 1962. *Manual of Field Geology*, John Wiley & Sons Inc., New York, New York.

Neuendorf, K.K.E, et. Al. 2005. *Glossary of Geology, Fifth Edition*, American Geological Institute.

Soil Test Inc. 1975. *Munsell Color Chart*. Evanston, Illinois.

U. S. Army Corp of Engineers. 1994. *Rock Foundations, EM 1110-1-2908*, Chapter 4. November 30.

\_\_\_\_\_. 1998. *Monitoring Well Design, Installation, and Documentation at Hazardous Toxic, and Radioactive Waste Sites, EM 1110-1-4000*, Chapter 4. November 1.

U. S. Department of Agriculture Soil Conservation Service. 1999. *Soil Taxonomy, A Basic System of Soil Classification for Making and Interpreting Soil Surveys*. Second Addition.

Woodward, L.A. 1988. *Laboratory Manual Physical Geology*, University of New Mexico Printing. Albuquerque, New Mexico.

## Lithologic Logging

SOP 3-5  
Revision: 9  
Date: February 2015

### 8.0 Attachments

**Note:** These Attachments are for informational purposes. Other equivalent charts such as USCS or logs may be used.

Attachment A - Lithologic Logs

Attachment B - Grain-Size Scale; Graph determining size of sedimentary particles, particle degree of roundness charts

Attachment C - Comparison Chart for Estimating Percentage Composition

Attachment D - Classification of Igneous Rocks

Attachment E - Classification of Sedimentary Rocks

Attachment F - Classification of Metamorphic Rocks

Attachment G - Lithologic Symbol Chart

Attachment H - Common Abbreviations for Lithologic Logging

Attachment I - Naming of Unconsolidated Materials

Attachment J - Sorting Chart

Attachment K - Example of Unified Soil Classification System (USCS)

**Lithologic Logging**

SOP 3-5  
 Revision: 9  
 Date: February 2015

**Attachment A**

**Lithologic Logs**

|  |  |  |  |                         |  |
|--|--|--|--|-------------------------|--|
| <b>CORING LOG</b>                                  |  | Client   |  | Boring Number           |  |
| Company Name<br>CDM Smith                          |  | Drilling Subcontractor                                   |  | Sheet 1 of Sheets       |  |
| Project  |  | Location   |  |                         |  |
| Name of Driller                                    |  | Drill Rig(s)   |  |                         |  |
| Sizes and Types of Drilling and Sampling Equipment |  | Northing   |  | Easting                 |  |
|  |  | ORNL Grid  |  |                         |  |
|  |  | Surface Elevation  |  |                         |  |
|  |  | Date Started   |  | Date Completed          |  |
| Overburden Thickness                               |  | Depth Groundwater Encountered                            |  |                         |  |
| Depth Drilled into Rock                            |  | Depth to Water and Elapsed Time After Drilling Completed |  |                         |  |
| Total Depth of Hole                                |  | Other Water Level Measurements (Specify)                 |  |                         |  |
| Drilling Method                                    |  | Borehole Diameter(s)                                     |  | Depth of Surface Casing |  |
| Total Core Recovery                                |  | Total Number of Core Boxes                               |  | Signature of Geologist  |  |

Location Map

Project

Boring Number

**Lithologic Logging**

SOP 3-5  
 Revision: 9  
 Date: February 2015

**Attachment A**

**Lithologic Logs (cont.)**

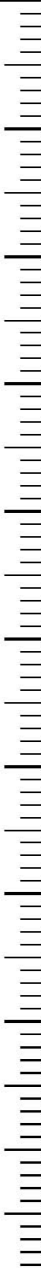
| <b>CORING LOG</b><br>(continuation sheet) |  |                          |              |                               |              |     | Boring Number:  |  |
|---|--|--------------------------|--------------|-------------------------------|--------------|-----|-----------------|--|
| Project:                                  |  |                          |              |                               | Geologist:   |     | Sheet of Sheets |  |
| Elev (ft)                                 | Depth (ft) logs  | Description of Materials | USC&SI Title | Field Screening Results (ppm) | Core Run No. | RQD | Recovery (ft)   | Remarks  |
|   |  |                          |              |                               |              |     |                 |  |
| Project:                                  |  |                          |              |                               |              |     | Boring Number:  |  |



**Lithologic Logging**

SOP 3-5  
 Revision: 9  
 Date: February 2015

**Attachment A**

**Lithologic Logs (cont.)**

|  |  |                      |  |                        |                   |           |
|--|--|----------------------|--|------------------------|-------------------|-----------|
| <b>DRILLING LOG</b>                                |  |                      | Client   |                        | Boring Number     |           |
| Company Name<br>CDM Smith                          |  |                      | Drilling Subcontractor                                   |                        | Sheet 1 of Sheets |           |
| Project  |  |                      | Location   |                        |                   |           |
| Name of Driller                                    |  |                      | Drill Rig(s)   |                        |                   |           |
| Sizes and Types of Drilling and Sampling Equipment |  |                      | Northing   |                        | Easting           | ORNL Grid |
|  |  |                      | Surface Elevation  |                        |                   |           |
|  |  |                      | Date Started   |                        | Date Completed    |           |
| Overburden Thickness                               |  |                      | Depth Groundwater Encountered                            |                        |                   |           |
| Depth Drilled into Rock                            |  |                      | Depth to Water and Elapsed Time After Drilling Completed |                        |                   |           |
| Total Depth of Hole                                |  |                      | Other Water Level Measurements (Specify)                 |                        |                   |           |
| Drilling Method                                    |  | Borehole Diameter(s) | Depth of Surface Casing                                  | Signature of Geologist |                   |           |
| Location Map                                       |  |                      |  |                        |                   |           |
| Project  |  |                      |  |                        | Boring Number     |           |



Lithologic Logging

SOP 3-5  
Revision: 9  
Date: February 2015

Attachment B

Grain-Size Scale; Graph determining size of particles,  
particle degree of roundness charts

AGI DATA SHEET 28.1

**Grain-size Scales**  
By Roy L. Ingram, University of North Carolina  
GRAIN-SIZE SCALE USED BY AMERICAN GEOLOGISTS  
Modified Wentworth Scale — after Lane, et al., 1947, Trans. American Geophysical Union, v. 28, p. 936-938

| phi | GRADE LIMITS |         |        | U.S. Standard Sieve Series | GRADE NAME  |           |        |
|-----|--------------|---------|--------|----------------------------|-------------|-----------|--------|
|     | mm           | mm      | inches |                            |             |           |        |
| -12 | 4096         | -       | -161.3 | -                          | -           | -         | -      |
| -11 | 2048         | -       | 80.6   | -                          | very large  | -         | -      |
| -10 | 1024         | -       | 40.3   | -                          | large       | Boulders  | -      |
| -9  | 512          | -       | 20.2   | -                          | medium      | -         | -      |
| -8  | 256          | -       | 10.1   | -                          | small       | -         | -      |
| -7  | 128          | -       | 5.0    | -                          | large       | Cobbles   | -      |
| -6  | 64           | -       | 2.52   | 63 mm                      | small       | -         | GRAVEL |
| -5  | 32           | -       | 1.26   | 31.5 mm                    | very coarse | -         | -      |
| -4  | 16           | -       | 0.63   | 16 mm                      | coarse      | -         | -      |
| -3  | 8            | -       | 0.32   | 8 mm                       | medium      | Pebbles   | -      |
| -2  | 4            | -       | 0.16   | No. 5                      | fine        | -         | -      |
| -1  | 2            | -       | 0.08   | No. 10                     | very fine   | -         | -      |
| 0   | 1            | -       | 0.04   | No. 18                     | very coarse | -         | -      |
| +1  | 1/2          | 0.500   | -      | No. 35                     | coarse      | Sand      | SAND   |
| +2  | 1/4          | 0.250   | -      | No. 60                     | medium      | -         | -      |
| +3  | 1/8          | 0.125   | -      | No. 120                    | fine        | -         | -      |
| +4  | 1/16         | 0.062   | -      | No. 230                    | very fine   | -         | -      |
| +5  | 1/32         | 0.031   | -      | -                          | coarse      | -         | -      |
| +6  | 1/64         | 0.016   | -      | -                          | medium      | Silt      | -      |
| +7  | 1/128        | 0.008   | -      | -                          | fine        | -         | -      |
| +8  | 1/256        | 0.004   | -      | -                          | very fine   | -         | MUD    |
| +9  | 1/512        | 0.002   | -      | -                          | coarse      | -         | -      |
| +10 | 1/1024       | 0.001   | -      | -                          | medium      | Clay size | -      |
| +11 | 1/2048       | 0.0005  | -      | -                          | fine        | -         | -      |
| +12 | 1/4096       | 0.00025 | -      | -                          | very fine   | -         | -      |

AGI-28-1-88

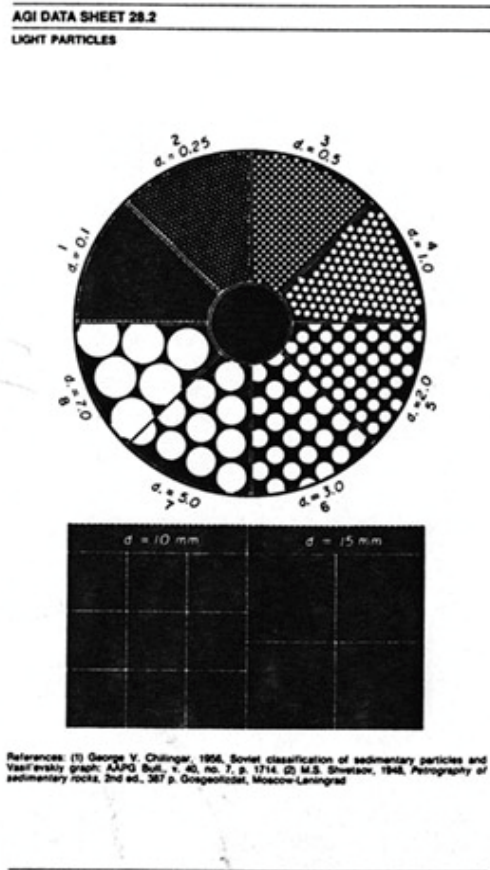

American Geological Institute, Data Sheets, Third Edition, 1989.



Very angular      Angular      Sub-angular      Sub-rounded      Rounded      Well rounded

Compton, R.R., Manual of Field Geology, 1962.

Attachment C

Comparison Chart for Estimating Percentage Composition

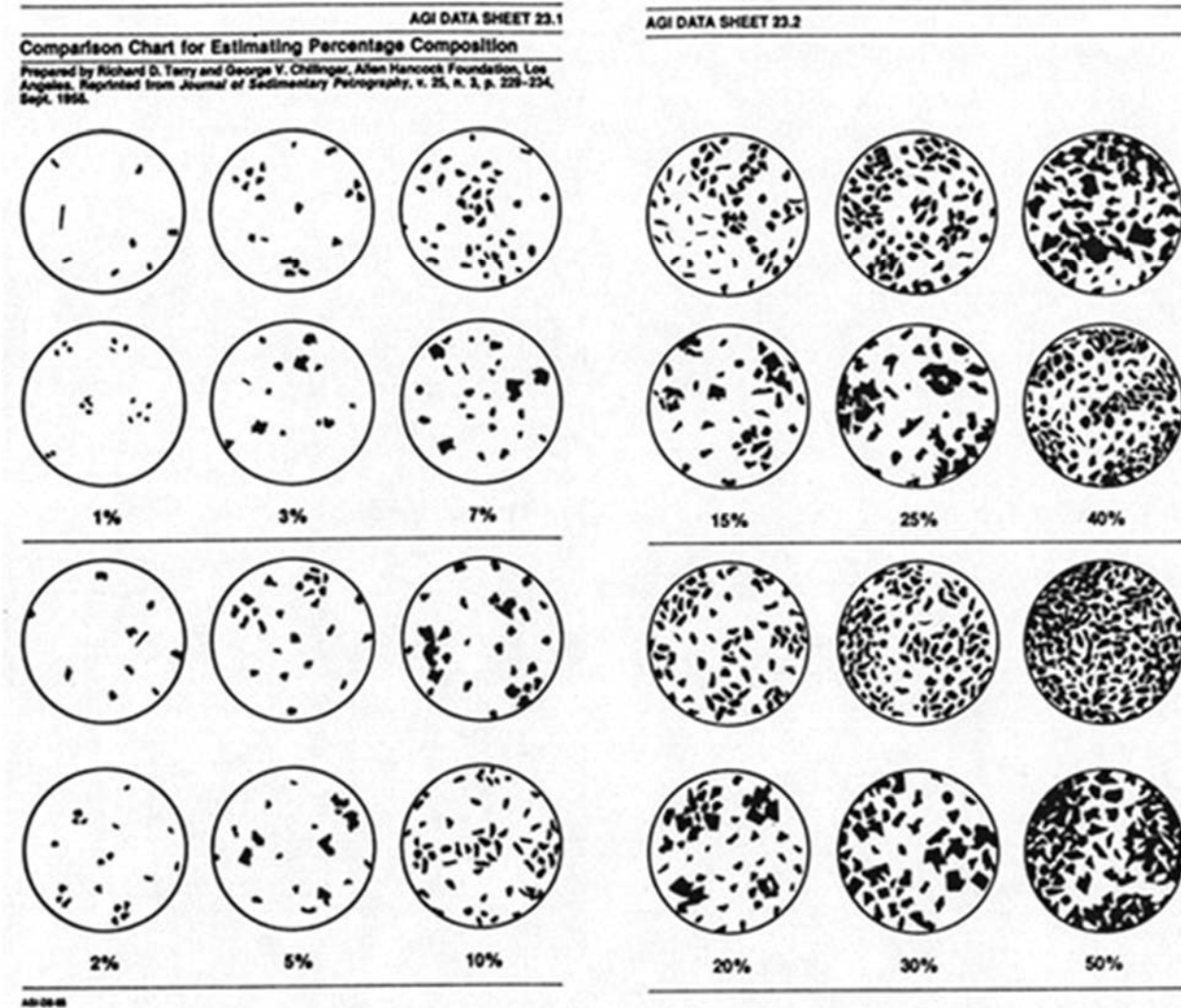

American Geological Institute, Data Sheets, Third Edition, 1989.

**Attachment D**

**Classification of Igneous Rocks**

| Classification of Igneous Rocks |  |   |  |                      |                                     |
|---------------------------------|--|---|--|----------------------|-------------------------------------|
| Mineral Composition             |  |   |  |                      |                                     |
|                                 | Quartz >10%<br>Abundant feldspar<br>Mafic minerals minor | Quartz <10%<br>Abundant feldspar<br>Mafic minerals moderate | Feldspar abundant<br>Mafic<br>Minerals 40-70%;<br>Quartz minor or absent | Mafic minerals >70%  |                                     |
| Color Index                     | Light Color  | Intermediate color  | Dark   | Dark                 |                                     |
| Chemistry                       | SiO <sub>2</sub> 70%                                     | SiO <sub>2</sub> 60%  | SiO <sub>2</sub> 50%   | SiO <sub>2</sub> 40% |                                     |
|                                 | Phaneritic (visible with naked eye)                      | Granite (Gr)  | Diorite (Dr)   | Gabbro (Gb)          | Peridotite (Pr)<br>(mostly olivine) |
| T<br>E<br>X<br>T<br>U<br>R<br>E | Aphanitic (microscopic)                                  | Rhyolite (Ry)<br>(quartz phenocrysts)                       | Andesite (An)<br>(feldspar or mafic phenocrysts; no quartz)              | Basalt (Ba)          | Komatiite (Km)<br>(very rare)       |
|                                 |  | Felsite (Fl)<br>(no phenocrysts)                            |  |                      |                                     |
|                                 | Glassy   | Obsidian (ob) Pumice (Pu)                                   |  | Rare                 |                                     |
|                                 | Glassy-Fragmental (Pyroclastic)                          | Tuff <4mm (Tf)<br>Breccia >4mm (Br)                         |  | Rare                 |                                     |

## Lithologic Logging

SOP 3-5

Revision: 9

Date: February 2015

## Attachment E

## Classification of Sedimentary Rocks

| Classification of Sedimentary Rocks |   |   |   |   |
|-------------------------------------|---|---|---|---|
| <b>Detrital</b>                     | <b>Detrital Classification</b>                                      | <b>Principal Composition</b>                      | <b>Additional Identifying Characteristics</b>   | <b>Name of Rock</b>                           |
|                                     | Rudaceous<br>(clast diameter > 2 mm)                                | Gravel  | Rounded Clasts  | Conglomerate (Cg)                             |
|                                     |   |   | Angular Clasts  | Breccia (Br)                                  |
|                                     | Arenaceous<br>(clast diameter between 0.0625 mm [1/16 mm] and 2 mm) | Sand  | Mineral composition and detrital matrix content varies. Additional detrital matrix qualifiers (arenite or wacke) and mineral composition qualifiers (quartz, arkose, feldspathic, etc.) may be necessary. | Sandstone (Sa)                                |
|                                     | Argillaceous<br>(clast diameter <0.0625 mm)                         | Mud   | Non-fissile along bedding planes, silt predominant over clay  | Siltstone (Sls)                               |
|                                     |   |   | Non-fissile along bedding planes, clay predominant over silt  | Claystone                                     |
|                                     |   |   | Non-fissile along bedding planes, silt and clay fraction approximately equal or unknown   | Mudstone (Ms)                                 |
|                                     |   |   | Fissile along bedding planes  | Shale (Shl)                                   |
| <b>Chemical</b>                     | <b>Chemical Classification</b>                                      | <b>Principal Composition</b>                      | <b>Additional Identifying Characteristics</b>   | <b>Name of Rock</b>                           |
|                                     | Calcareous  | Calcite<br>(Calcium Carbonate)                    | Effervesces on contact with dilute HCl  | Limestone (La)                                |
|                                     |   | Dolomite (Calcium Magnesium Carbonate)            | Pulverized sample effervesces on contact with dilute HCL  | Dolomite (DI),<br>Dolostone                   |
|                                     | Siliceous   | Quartz (Silicon Dioxide)                          | Hard, dense, fractures conchoidally   | Chert (Ch)                                    |
|                                     | Evaporites  | Hydrated Calcium Sulfate                          | Earthy and crumbly  | Gypsum (Gy)                                   |
|                                     |   | Calcium Sulfate                                   | Usually exhibits indistinct stratification  | Anhydrite                                     |
|                                     |   | Halite (Sodium Chloride)                          | Cubic cleavage  | Rock Salt (Na)                                |
|                                     | <b>Organic<br/>(Organogenetic or Biochemical)</b>                   | <b>Chemical Classification</b>                    | <b>Principal Composition</b>  | <b>Additional Identifying Characteristics</b> |
| Calcareous                          |   | Fossil shells and fragments                       | Loosely cemented fragmental limestone   | Coquina (Cq)                                  |
|                                     |   | Foraminiferal shells                              | Soft, micritic limestone  | Chalk (Chk)                                   |
|                                     |   | Calcite or aragonite                              | Derived from evaporation of spring water  | Travertine (Tvr)                              |
| Siliceous                           |   | Diatom shells (saltwater or freshwater organisms) | Light-colored, soft, friable, and porous siliceous deposit  | Diatomite (Dm)                                |
| Carbonaceous                        |   | Plant Remains                                     | Degree of lithification varies-additional qualifiers such as peat, lignite, bituminous and anthracite may be necessary.   | Coal (Cl)                                     |

## Attachment F

## Classification of Metamorphic Rocks

| Classification of Metamorphic Rocks                |   |  |   |
|--|---|--|---|
| Structure  | Texture                                 | Chief Minerals   | Name  |
| N<br>o<br>n<br><br>f<br>o<br>l<br>i<br>a<br>t<br>e | granular; breaks across grains          | quartz   | Quartzite (Qzt)                                       |
|  | granular; grains clearly visible        | calcite  | Marble (Mbl)  |
|  | granular; grains altered and indistinct | plagioclase, chlorite, epidote, hornblende               | Greenstone (Grs)                                      |
|  | very fine-grained                       | indistinguishable; mostly submicroscopic micas and clays | Hornfels (Hnf)  |
| F<br>o<br>l<br>i<br>a<br>t<br>e                    | slaty                                   | submicroscopic mica, quartz                              | Slate (Sl)  |
|  | phyllitic                               | microscopic mica, quartz                                 | Phyllite (Pyl)  |
|  | schistose                               | microscopic mica, quartz, amphibole                      | Blueschist  |
|  |   | chlorite, mica, plagioclase                              | chlorite schist (CL-Sch)                              |
|  |   | muscovite, quartz  | Muscovite (Ms) Schist (Sch)                           |
|  |   | garnet, muscovite  | Garnet (G) Muscovite (Ms) Schist (Sch)                |
|  |   | hornblende, plagioclase                                  | Amphibolite (Amp)                                     |
|  |   | staurolite, garnet, muscovite                            | Garnet (G) Staurolite (S) Muscovite (Ms) Schist (Sch) |
|  | gneissose                               | plagioclase, hornblende                                  | Amphibolite (Amp) Gneiss (Gns)                        |
|  |   | feldspar, quartz   | Granite (Gr) Gneiss (Gns)                             |
|  |   | eye-shaped feldspar, mica                                | Augen (Au) Gneiss (Gns)                               |

**Lithologic Logging**

**Attachment G**

**Lithologic Symbol Chart**

**Symbols for Sedimentary Rocks**

|  |                   |
|--|-------------------|
|  | Conglomerate      |
|  | Breccia           |
|  | Massive Sandstone |
|  | Shale             |
|  | Siltstone         |
|  | Mudstone          |
|  | Massive Limestone |
|  | Cherty Limestone  |
|  | Shelly Limestone  |
|  | Travertine        |
|  | Dolomite          |
|  | Chert, Bedded     |
|  | Gypsum            |
|  | Rocksalt          |
|  | Coal              |
|  | Coquina           |
|  | Chalk, Diatomite  |

**Symbols for Metamorphic Rocks**

|  |            |
|--|------------|
|  | Quartzite  |
|  | Marble     |
|  | Greenstone |
|  | Hornfels   |
|  | Slate      |
|  | Phyllite   |
|  | Schist     |
|  | Gneiss     |

**Symbols for Grains**

|  |                     |
|--|---------------------|
|  | Silt                |
|  | Sand                |
|  | Pebbles             |
|  | Cobbles             |
|  | Shaly, Argillaceous |
|  | Calcareous, Caliche |
|  | Shells              |
|  | Cherts              |

**Symbols for Igneous Rocks**

|  |                          |
|--|--------------------------|
|  | Tuff and Tuff Breccia    |
|  | Basic lava flows         |
|  | Light colored lava flows |
|  | Porphyritic              |
|  | Granitic                 |
|  | Serpentine               |
|  | Aphanitic or Massive     |

**Symbols for Bedding**

|  |                  |
|--|------------------|
|  | Ss xbdd          |
|  | Ss lam           |
|  | Ss lens in shale |
|  | Bioturbated      |
|  | Fractures        |
|  | Vugs             |

Compton, R.R., Manual of Field Geology, 1962.



## Lithologic Logging

SOP 3-5

Revision: 9

Date: February 2015

## Attachment H

## Common Abbreviations for Lithologic Logging

| Common Abbreviations   |                       |                      |
|------------------------|-----------------------|----------------------|
| Abundant – abnt        | Diameter – dia        | Laminated – lam      |
| Amount – amt           | Different – diff      | Maximum – max        |
| Approximate – approx   | Disseminated – dissem | Pebble – pbl         |
| Arenaceous – aren      | Elevation – elev      | Phenocryst – phen    |
| Argillaceous – arg     | Equivalent – equiv    | Porphyritic – proph  |
| Average – ave          | foliated – fol        | Probable – prob      |
| Bedded – bdd           | Formation frm         | Quartz – qrz         |
| Bedding – bdg          | Fracture – frac       | Regular – reg        |
| Calcareous – calc      | Fragmental – frag     | Rocks – rx           |
| Cemented – cmt         | Granular – Gran       | Rounded – rnd        |
| Cobble – cbl           | Gypsiferous – Gyp     | Saturated – sat      |
| Contact – ctc          | Horizontal – hriz     | Secondary – sec      |
| Cross-bedded - xbdd    | Igneous – ign         | Siliceous – sil      |
| Cross-bedding – xbdg   | Inclusion – incl      | Structure – struc    |
| Cross-laminated – xlam | Interbedded – intbdd  | Unconformity – uncnf |
| Crystal – xl           | Irregular – ireg      | Variegated – vrgt    |
| Crystalline – xln      | Joint – jnt           | Vein – vn            |
| Grain Size             | Contacts              | Sorting              |
| grain – gn             | gradational – grad    | poor – pr            |
| fine – f               | erosional – er        | moderate – mod       |
| very fine – vf         | abrupt – ab           | well – well          |
| medium – med           |                       |                      |
| coarse – crs           | Fabric                |                      |
| large – lg             | grain supported – gs  |                      |
| very large – vlg       | matrix supported – ms |                      |
| small – sm             | imbricate – im        |                      |

Adapted from, Compton, R.R., *Manual of Field Geology*, 1962.

## Lithologic Logging

SOP 3-5

Revision: 9

Date: February 2015

## Attachment I

## Naming of Unconsolidated Materials

| Main Particle              | Gravel              | Sand                 | Silt                | Clay                |
|----------------------------|---------------------|----------------------|---------------------|---------------------|
| > 15 % gravel              | Gravel              | Gravelly Sand        | Gravelly Silt       | Gravelly Clay       |
| > 15 % sand                | Sandy Gravel        | Sand                 | Sandy Silt          | Sandy clay          |
| > 15 % silt                | Silty Gravel        | Silty Sand           | Silt                | Silty Clay          |
| > 15 % clay                | Clayey Gravel       | Clayey Sand          | Clayey Silt         | Clay                |
| 5-15 % gravel              | Not Applicable      | Sand with Gravel     | Silt with Gravel    | Clay with Gravel    |
| 5-15 % sand                | Gravel with sand    | Not applicable       | Silt with Sand      | Clay with sand      |
| 5-15 % silt                | Gravel with silt    | Sand with silt       | Not applicable      | Clay with silt      |
| 5-15 % clay                | Gravel with clay    | Sand with clay       | Silt with clay      | Not applicable      |
| > 15% gravel plus 15% sand | Sandy Gravel        | Gravelly Sand        | Gravelly Sandy Silt | Gravelly Sandy Clay |
| > 15% gravel plus 15% silt | Silty Gravel        | Gravelly Silty Sand  | Gravelly Silt       | Gravelly Silty Clay |
| > 15% gravel plus 15% clay | Clayey Gravel       | Gravelly Clayey Sand | Gravelly Sandy Silt | Gravelly Clay       |
| > 15% sand plus 15% silt   | Silty Sand Gravel   | Silty Sand           | Sandy Silt          | Sandy Silty Clay    |
| > 15% sand plus 15% clay   | Sandy Clayey Gravel | Clayey Sand          | Sandy Clayey Silt   | Sandy Clay          |
| > 15% silt plus 15% clay   | Silty Clayey Gravel | Silty Clayey Sand    | Clayey Silt         | Silty Clay          |

**Note:** Other combinations are possible when all particle sizes are present in greater than 15%. For example, a Silty Clayey Gravelly Sand. Other possible combinations exist such as a Gravelly Sand with silt.

Compton, R.R., *Manual of Field Geology*, 1962.

**Lithologic Logging**

SOP 3-5  
Revision: 9  
Date: February 2015

**Attachment J**



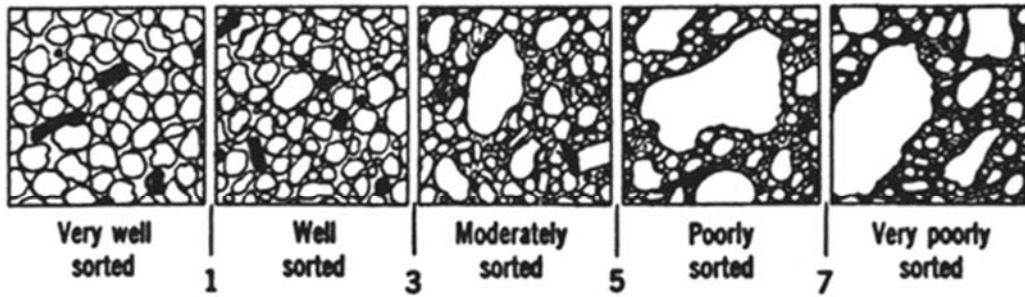

**Sorting Chart**



Compton, R.R., Manual of Field Geology, 1962.

Attachment K

Example of Unified Soil Classification System (USCS)

| Unified Soil Classification System (USCS) |                  |                   |   |
|---|------------------|-------------------|---|
|   | MILLIMETERS      | INCHES            | SIEVE SIZES   |
| <b>BOULDERS</b>                           | <b>&gt; 300</b>  | <b>&gt; 11.8</b>  | -   |
| <b>COBBLES</b>                            | <b>75 - 300</b>  | <b>2.9 - 11.8</b> | -   |
| <b>GRAVEL:</b>                            |                  |                   |   |
| <b>COARSE</b>                             | <b>75 - 19</b>   | <b>2.9 - .75</b>  | -   |
| <b>FINE</b>                               | <b>19 - 4.8</b>  | <b>.75 - .19</b>  | <b>3/4" - No. 4</b>   |
| <b>SAND:</b>                              |                  |                   |   |
| <b>COARSE</b>                             | <b>4.8 - 2.0</b> | <b>.19 - .08</b>  | <b>No. 4 - No. 10</b>      |
| <b>MEDIUM</b>                             | <b>2.0 - .43</b> | <b>.08 - .02</b>  | <b>No. 10 - No. 40</b>     |
| <b>FINE</b>                               | <b>.43 - .08</b> | <b>.02 - .003</b> | <b>No. 40 - No. 200</b>  |
| <b>FINES:</b>                             |                  |                   |   |
| <b>SILTS</b>                              | <b>&lt; .08</b>  | <b>&lt; .003</b>  | <b>&lt; No. 200</b>      |
| <b>CLAYS</b>                              | <b>&lt; .08</b>  | <b>&lt; .003</b>  | <b>&lt; No. 200</b>   |

## Attachment K

Example of Unified Soil Classification System (USCS)  
(Continued)

## C L A Y

| CLAY CONSISTENCY | THUMB PENETRATION   | SPT, N BLOWS/ FT. | Undrained Shear Strength $c$ (PSF) | Unconfined Compressive Strength $q_u$ |
|------------------|---|-------------------|------------------------------------|---------------------------------------|
|                  |   |                   | TORVANE                            | Pocket Penetrometer                   |
| VERY SOFT        | Easily penetrated several inches by thumb. Exudes between thumb and finger's when squeezed in hand. | < 2               | 250                                | 500                                   |
| SOFT             | Easily penetrated one inch by thumb. Molded by light finger pressure.                               | 2 - 4             | 250 - 500                          | 500 - 1000                            |
| MEDIUM STIFF     | Can be penetrated over 1/4" by thumb with moderate effort. Molded by strong finger pressure.        | 4 - 8             | 500 - 1000                         | 1000 - 2000                           |
| STIFF            | Indented about 1/4" by thumb but penetrated only with great effort.                                 | 8 - 15            | 1000 - 2000                        | 2000 - 4000                           |
| VERY STIFF       | Readily indented by thumbnail.  | 15 - 30           | 2000 - 4000                        | 4000 - 8000                           |
| HARD             | Indented with difficulty by thumbnail.  | > 30              | > 4000                             | > 8000                                |

## S A N D

| SOILTYPE          | SPT, N Blows/ft. | Relative Density, % | FIELD TEST  |
|-------------------|------------------|---------------------|---|
| VERY LOOSE SAND   | 4                | 0 - 15              | Easily penetrated with 1/2" reinforcing rod pushed by hand.                     |
| LOOSE SAND        | 4 - 10           | 15 - 35             | Easily penetrated with 1/2" reinforcing rod pushed by hand.                     |
| MEDIUM DENSE SAND | 10 - 30          | 35 - 65             | Penetrated a foot with 1/2" reinforcing rod driven with 5-lb hammer.            |
| DENSE SAND        | 30 - 50          | 65 - 85             | Penetrated a foot with 1/2" reinforcing rod driven with 5-lb hammer.            |
| VERY DENSE SAND   | 50               | 85 - 100            | Penetrated only a few inches with 1/2" reinforcing rod driven with 5-lb hammer. |

## Lithologic Logging

SOP 3-5

Revision: 9

Date: February 2015

## Attachment K

**Example of Unified Soil Classification System (USCS)  
(Continued)**

| Summary of USCS Field Identification Tests   |   |                     |  |   |                  |                   |                |
|--|---|---------------------|--|---|------------------|-------------------|----------------|
| <b>Coarse-Grained Soils</b><br>More than half the material (by weight) is individual grains visible to the naked eye                         | <b>Gravelly Soils</b><br>More than half of coarse fraction is larger than 4.75 mm |                     | <b>Clean Gravels</b><br>Will not leave a stain on a wet palm | Substantial amounts of all grain particle sizes                                 |                  |                   | GW             |
|  |   |                     |  | Predominantly one size or range of sizes with some intermediate sizes missing   |                  |                   | GP             |
|  |   |                     | <b>Dirty Gravels</b><br>Will leave a stain on a wet palm     | Non-plastic fines (to identify, see ML below)                                   |                  |                   | GM             |
|  |   |                     |  | Plastic fines (to identify, see CL below)                                       |                  |                   | GC             |
|  | <b>Sandy Soils</b><br>More than half of coarse fraction is smaller than 4.75 mm   |                     | <b>Clean Sands</b><br>Will not leave a stain on a wet palm   | Wide range in grain size and substantial amounts of all grain particle sizes.   |                  |                   | SW             |
|  |   |                     |  | Predominantly one size or a range of sizes with some intermediate sizes missing |                  |                   | SP             |
|  |   |                     | <b>Dirty Sands</b><br>Will leave a stain on a wet palm       | Non-plastic fines (to identify, see ML below)                                   |                  |                   | SM             |
|  |   |                     |  | Plastic fines (to identify, see CL below)                                       |                  |                   | SC             |
| <b>Fine-Grained Soils</b><br>More than half the material (by weight) is individual grains not visible to the naked eye<br><br>( $<0.074$ mm) | <b>Ribbon</b>   | <b>Liquid Limit</b> | <b>Dry Crushing Strength</b>                                 | <b>Dilatancy Reaction</b>   | <b>Toughness</b> | <b>Stickiness</b> |                |
|  | None  | <50                 | None to Slight   | Rapid   | Low              | None              | ML             |
|  | Weak  | <50                 | Medium to High   | None to Very Slow   | Medium to High   | Medium            | CL             |
|  | Strong  | >50                 | Slight to Medium   | Slow to None  | Medium           | Low               | MH             |
|  | Very Strong   | >50                 | High to Very High  | None  | High             | Very High         | CH             |
| <b>Highly Organic Soils</b>  | Readily identified by color, odor, spongy feel, and frequently by fibrous texture |                     |  |   |                  |                   | OL<br>OH<br>Pt |

**Underground Facility Location\***

*\*Applicable only if CDM Smith, its subcontractor, or lower-tier subcontractor performs the intrusive work. Consult with responsible party for all other situations.*

SOP 3-6

Revision: 2

Date: February 2015

Approved:



Signature

Technical Review:

Stuart Barden

**1.0 Objective**

The objective of this technical standard operating procedure (SOP) is to provide background information, resources, and guidance for locating underground facilities prior to performing excavations or other intrusive activities such as soil boring or demolition activities.

**2.0 Background**

To protect the public health and avoid serious and costly accidents that occur each year due to damage to underground utilities from excavation and other intrusive activities, most states have enacted laws and promulgated regulations that require notification and markout of underground utilities prior to performing excavation or other intrusive activities. These laws also require underground facility owners and operators to locate, markout, or otherwise provide the location of underground facilities that they operate so that contractors and others performing intrusive activities can take reasonable care to avoid damaging the facilities.

All states, and in some cases, localities within states, have established "one-call" type systems to facilitate location of underground facilities. These systems typically are operated by independent entities that are funded by the underground facility operators. They provide communication and verification services for locating underground facilities. One-call system operators are responsible for contacting the appropriate underground facility owners, ordering markouts, and tracking markout orders. The one-call system operator maintains records of requests for markouts and also maintains contact information for the field supervisor or other responsible person who requested the markout. This simplifies the process for contractors and allows them to take reasonable care to avoid accidental damage to underground utilities.

Most state laws require contractors to contact the one-call system prior to performing intrusive activities. The contractor (CDM Smith) must provide information including the site location (in some cases, the boundary of the excavation must be marked out), proposed start date, depth of the excavation, and contact information for a representative of the contractor, etc. Most laws provide for civil penalties for violation of the law and some provide for criminal penalties for negligence if an underground facility is damaged and the one-call system was not contacted.

Each state law is different, and it is the responsibility of the contractor to understand the law and activate the state's one-call system. Most states maintain web sites that provide one-call system information and offer downloadable forms for requesting subsurface facility markouts. Many of the one-call web sites also provide state regulations, procedures for using the system, procedures to follow if an underground facility is struck, and other important information. A list of telephone numbers to activate the one-call system in various states and localities is provided in Attachment A.

Often responsibility for contacting the one-call system and confirming the markout is transferred, by contract, to the subcontractor performing the intrusive work (i.e., driller, excavator, etc.). It is important to take reasonable care to ensure that the subcontractor has contacted the one-call system, that the markout has been completed, and that it includes the area where the intrusive activity will occur. No work should occur until the site manager or field manager is confident that the subcontractor has met their responsibility as defined in the subcontract statement of work.

Using a one-call system is not a guarantee that all underground facilities in an area have been identified. Not all facility operators participate in the one-call system or they may be exempt from participation by law. The one-call system operator can provide information on participating operators. Operators of exempted or nonparticipating underground facilities must be contacted directly to determine the location of their facilities. Responsibility for contacting these operators and locating the underground facilities may be transferred to a subcontractor via the subcontract statement of work. If responsibility is not transferred to a subcontractor, then it is the responsibility of the CDM Smith site manager or designee to contact the facility operator and determine the location of the underground facility.

**Underground Facility Location\***

SOP 3-6

Revision: 2

Date: February 2015

*\*Applicable only if CDM Smith, its subcontractor, or lower-tier subcontractor performs the intrusive work. Consult with responsible party for all other situations.*

**2.1 Definitions**

**Excavation** - State laws often define this term broadly to mean any movement of any earthen materials or rock, especially by means of machinery or explosives. Excavations below minimum depths (e.g., 12 inches) may trigger activation of the one-call system. For example, New Jersey's Underground Facility Protection Act defines excavation as:

“...any operation in which earth, rock, or other material in the ground is moved, removed, or otherwise displaced by means of any tools, equipment, or explosive, and includes but is not limited to drilling, grading, boring, milling, to a depth greater than six inches, trenching, tunneling, scraping, tree and root removal, cable or pipe plowing, fence post or pile driving, and wrecking, razing, rending, or removing any structure or mass material, but does not include routine residential property or right of way landscaping activities performed with non-mechanized equipment, excavation within the flexible or rigid pavement box within the right-of-way, or the tilling of soil for agricultural purposes to a depth of 18 inches or less.”

**One-Call Operator** - The person identified by the one-call system as the point of contact for location of underground facilities. The one-call operator is responsible for obtaining excavation location information from the excavator, contacting facility operators, ordering the markout, and providing verification that the markout has been completed.

**One-Call System** - Any of a number of communication systems established by state or local law to provide underground facility markout services to protect underground facilities. There are a number of state and regional one-call systems such as Dig Safe, Call Before You Dig, One Call, Miss Utility, and others.

**Underground Facilities** - Typically public or private facilities that are buried below ground or submerged on public or private property and used to convey water, sewage, telecommunications, cable television, electricity, oil, petroleum, gas, optical signals, or traffic control. Be aware that some regulations may exclude certain facilities such as storm drains and gravity sewers.

**Operator** - Person or entity that owns or operates an underground facility as defined above. One-call laws generally require operators to provide the location of their facilities and to perform the markout. Homeowners who operate underground facilities, such as lawn sprinklers, are usually not considered to be operators.

**Waiting Period** - Most one-call systems establish a minimum time to allow the markout to be completed before excavation activities can proceed. Lead times vary by state but usually are 2 to 3 business days.

**Expiration Date** - Some states require that the excavation activities must begin within a certain time period after the markout is completed or after the one-call system is contacted. The party responsible for locating the underground facilities is also responsible for maintaining the markouts (e.g., ensuring that markouts remain clearly visible for the duration of intrusive activities). If work is delayed, check with the one-call system to ensure that the markout remains valid.

**2.2 Discussion**

**Excavation Activities on Residential Properties** - Underground facility markouts often do not extend onto residential properties. Markouts usually show residential connections at the boundaries of the property, but end there. Excavation activities planned on residential properties require the use of other methods to determine the location of underground utilities such as water lines, electrical lines, septic systems, leach fields, and sewer lines. In addition, homeowners may install other underground facilities such as water sprinkler systems, low voltage lighting lines, well piping, and swimming pool plumbing.

The planning process for conducting work on residential properties must consider the activities that will be performed and their locations relative to the building footprint. Information about the location of underground utilities may be obtained from the residents before performing intrusive activities, but this information is often uncertain. Procurement of a geophysical subcontractor experienced in locating underground utilities is often the best choice to avoid damage to residential underground facilities. The responsibilities of the subcontractor for locating underground facilities should be clearly defined in the subcontract statement of work. Additional methods for avoiding utilities include hand digging and use of a vacuum system to remove soil from the excavation.



**Underground Facility Location\***

SOP 3-6

Revision: 2

Date: February 2015

*\*Applicable only if CDM Smith, its subcontractor, or lower-tier subcontractor performs the intrusive work. Consult with responsible party for all other situations.*

**Use of an Underground Facility Location Subcontractor** - In some situations or in particular areas of the country, it is customary to procure the services of a subcontractor experienced with providing utility markout services. This may be particularly useful for sites that cover large areas and require numerous markouts or in certain areas of the country where these services are used to identify underground facilities. For example, in some western states, the one-call systems are operated at the county or regional level and may require more coordination activities. The subcontractor must comply with all state and local regulations including activation of the one-call system. When this option is selected to identify underground facilities, the procedures described below for subcontractor as the excavator should be followed. The responsibilities of the subcontractor for locating underground facilities should be clearly defined in the subcontract statement of work.

**2.3 Associated Procedures**

- SOP 1-4, *Subsurface Soil Sampling*
- SOP 3-1, *Geoprobe® Sampling*
- SOP 4-4, *Design and Installation of Monitoring Wells in Aquifers*

**3.0 Responsibilities**

**Project Manager** - The project manager is responsible for ensuring that underground facility location responsibilities are clearly stated in subcontractor statements of work, as applicable.

**Site Manager** - The site manager is responsible for ensuring that the subcontractor has met their facility location responsibility as defined in the subcontract statement of work. If the underground facility location responsibility is not transferred to a subcontractor, it is the responsibility of the site manager to contact one-call and facility operators to determine locations.

**Field Manager** - The field manager is responsible for ensuring that work is not initiated until they are confident that underground facility location has occurred in the area of the work.

**4.0 Procedures*****General Procedures to Ensure that Underground Facilities are Identified Before Excavation***

**Note:** The terms 'excavator' and 'excavation' used in the following procedures are broadly defined to include a variety of intrusive activities including excavation, soil boring, well drilling, test excavations, etc.

**Subcontractor as the Excavator** - Frequently CDM Smith transfers the responsibility for contacting the appropriate one-call system, via the subcontract statement of work, to a subcontractor such as an excavator or driller. The procedures below apply to the location of underground facilities, when a subcontractor is responsible for contacting the one-call system, and identifying underground facilities.

- Clearly define the subcontractor's responsibility in locating underground facilities in the subcontract statement of work.
- Obtain and be aware of the state or local regulations concerning excavation activities and underground facilities (contact the one-call system's website or call the system operator).
- Define areas for excavation. Be as specific as possible with the location and include address, block and lot, milepost markers, cross streets, drawings, etc. (**Note** - State law may require that the proposed excavation area be physically delineated before the markout. Also be aware that methods for identifying locations vary from state to state).
- Provide the locations of the proposed excavations/borings to the subcontractor.

**Underground Facility Location\***

SOP 3-6

Revision: 2

Date: February 2015

*\*Applicable only if CDM Smith, its subcontractor, or lower-tier subcontractor performs the intrusive work. Consult with responsible party for all other situations.*

- Before beginning work, verify that the subcontractor has contacted the one-call system and that the required markouts have been completed. Obtain confirmation numbers or other documentation to verify that the subcontractor has contacted the one-call system or underground facility operator and that the markout has been completed. Obtain a list of the utilities that were contacted. Record all conversations with the subcontractor related to underground utility location in the field logbook.
- Before beginning the excavation activities, ensure that the appropriate area has been marked out and that the required waiting period has elapsed. Also, ensure that a delay in the start of the excavation activity has not invalidated the markout. If in doubt, contact the one-call system.
- Perform a walkover and visual inspection of the markout area. Identify any overhead hazards and establish appropriate offsets. Verify that the markout area covers the proposed excavation area. If any of the markouts are unclear or do not cover the excavation area, notify the subcontractor that the markout is not adequate. Request an additional markout if necessary.
- During the visual inspection, note the locations of features that may indicate underground facilities (manholes, sewer grates, vent pipes, electrical boxes, curb cuts, pavement patches, etc.). Depending on the state, not all utilities may be marked out (e.g., gravity sewers are excluded from New Jersey's underground facility protection law). Some facility operators may not have the resources to participate in the one-call system. The local municipality or utility must be contacted to determine the location of these underground facilities.
- Begin excavation activities. Be cautious during the initial stages of the intrusive activity. Be alert for signs that an underground facility may be present. Look for changes in the soil characteristics such as the presence of fill materials or non-native materials. Be alert for visual and aural cues that may indicate the presence of underground facilities (metallic sounds, changes in drilling progress, etc.). The party responsible for locating the underground facilities must maintain the markouts. Document maintenance of markouts in the field logbook and photographically.
- If an underground facility is struck or breached, cease operations immediately. Remove all personnel from the area, inform the subcontractor, contact the facility operator, inform your supervisor, and follow the emergency procedures in the site-specific health and safety plan. The subcontractor should immediately contact the one-call system and identify the problem.

**Note:** If CDM Smith takes an active role in contacting the one-call system, utility companies, or other operators of underground facilities, it may relieve the subcontractor of responsibility for locating the underground utilities. Before beginning intrusive activities, the site manager and subcontract manager should be consulted if it is believed that the subcontractor has not fulfilled his responsibility under the subcontract.

**CDM Smith as the Excavator** - The procedures below define reasonable steps to be taken to avoid damage to underground facilities when CDM Smith is the excavator. In most cases it is advisable to designate a subcontractor (via contract) as the party responsible for location of underground facilities.

- Obtain and be aware of the state or local regulations concerning excavation activities and underground facilities.
- Obtain a copy of the appropriate one-call system underground facility location request form to determine what information is required to submit an underground facility location request.
- Define areas for excavation. Be as specific as possible with the location and include address, lot and block, milepost markers, cross streets, drawings, etc. (**Note** - State law may require that the proposed excavation area be physically delineated before the markout).
- Contact the appropriate one-call system and provide information on the location of the proposed excavation and field manager or site manager contact information (provide the specific information required by the state's one-call system request form).

**Underground Facility Location\***

SOP 3-6

Revision: 2

Date: February 2015

*\*Applicable only if CDM Smith, its subcontractor, or lower-tier subcontractor performs the intrusive work. Consult with responsible party for all other situations.*

- Obtain a confirmation number or other documentation to verify that the markout has been completed. Obtain a list of the utilities that were contacted by the one-call system operator. Record all conversations with the one-call operator of underground utility operator in the field logbook.
- Before beginning the excavation activities, ensure that the appropriate area has been marked out and that the required waiting period has elapsed. Also, ensure that a delay in the start of the excavation activity has not invalidated the markout. If in doubt, contact the one-call system.
- Perform a walkover and visual inspection of the markout area. Identify any overhead hazards and establish appropriate offsets. Note the location of the marked out underground facilities and the proposed excavation location(s). If any of the markouts are unclear or do not cover the excavation area, contact the one-call system. Also during the visual inspection, note the locations of features that may indicate underground facilities (manholes, sewer grates, vent pipes, electrical boxes, curb cuts, pavement patches, etc.). Depending on the state, not all utilities may be marked out (e.g., gravity sewers are excluded from New Jersey's underground facility protection law). Other facility operators may not have the resources to participate in the one-call system. The local municipality or utility must be contacted to determine the location of these underground facilities.
- Determine what clearances are required between the location of the underground facility and the proposed excavation (clearances vary by state).
- Measure distance between proposed excavation and underground facility to ensure that proper clearance distance is maintained.
- Begin excavation activities. Be cautious during the initial stages of the excavation activity. Be alert for signs that an underground facility may be present. Look for changes in the soil characteristics such as the presence of fill materials or non-native materials. Be alert for visual and aural cues that may indicate the presence of an underground facility (metallic sounds, changes in drilling progress, etc.). The party responsible for locating the underground facilities must maintain the markouts. Document maintenance of markouts in the field logbook and photographically.
- If an underground facility is struck or breached, cease operations immediately. Remove all personnel from the area, contact the one-call system, inform your supervisor, contact the facility operator, and follow the emergency procedures in the site-specific health and safety plan.

**5.0 References**

New Jersey Statute, Title 48. 1997. Public Utilities, Chapter 2. Board of Public Utility Commissioners, Article 9. Underground Facility Protection.

New York State Department of Public Service, Safety Section, New York Department of Public Service, Rule 753. *Duties of Excavators*, Sections 753-3.2 - 753-3.17.

Dig Safe, Inc. website, [www.digsafe.com](http://www.digsafe.com).

New Jersey One Call website, [www.nj1-call.org](http://www.nj1-call.org).

New York State Electric and Gas (NYSEG) website, safety section, [www.nyseg.org](http://www.nyseg.org).

Dig Safely website, links to state laws and one-call contacts, [www.digsafely.com](http://www.digsafely.com).

**Field Logbook Content and Control**

SOP 4-1

Revision: 8

Date: February 2015

Approved:

  
Signature

Technical Review:

Robert Alexander

**1.0 Objective**

The objective of this technical standard operating procedure (SOP) is to set criteria for content entry and form of field logbooks. Field logbooks are an essential tool to document field activities for historical and legal purposes.

**2.0 Background****2.1 Definitions**

**Biota** - The flora and fauna of a region.

**Magnetic Declination Corrections** - Compass adjustments to correct for the angle between magnetic north and geographical meridians.

**2.2 Discussion**

Information recorded in field logbooks includes field team names; observations; data; calculations; date/time; weather; and description of the data collection activity, methods, instruments, and results. Additionally, the logbook may contain deviations from plans and descriptions of wastes, biota, geologic material, and site features including sketches, maps, or drawings as appropriate.

**3.0 General Responsibilities**

**Field Team Leader (FTL)** - The FTL is responsible for ensuring that the format and content of data entries are in accordance with this procedure.

**Site Personnel** - All CDM Smith employees who make entries in field logbooks during onsite activities are required to read this procedure before engaging in this activity. The FTL will assign field logbooks to site personnel who will be responsible for their care and maintenance. Site personnel will return field logbooks to the records file at the end of the assignment.

**Note:** Responsibilities may vary from site to site. Therefore, all field team member responsibilities should be defined in the field plan or site-/project-specific quality assurance project plan (QAPP).

**4.0 Required Equipment**

- Site-specific plans
- Indelible black or blue ink pen
- Field logbook
- Ruler or similar scale

**5.0 Procedures****5.1 Preparation**

In addition to this SOP, site personnel responsible for maintaining logbooks must be familiar with all procedures applicable to the field activity being performed. These procedures should be consulted as necessary to obtain specific information about equipment and supplies, health and safety, sample collection, packaging, decontamination, and documentation requirements. These procedures should be available electronically, or located at the field office or vehicle for easy reference.

Field logbooks shall be bound with lined, consecutively numbered pages. All pages must be numbered before initial use of the logbook. Before use in the field, each logbook will be marked with a specific document control number issued by the document control administrator, if required by the contract quality implementation plan (QIP). Not all contracts require document control numbers. The following information shall be recorded on the cover of the logbook:

- Field logbook document control number (if applicable).
- Start date of entries.

**Field Logbook Content and Control**

SOP 4-1

Revision: 8

Date: February 2015

- Activity (if the logbook is to be activity-specific), site name, and location.
- Name of CDM Smith contact and phone number(s) (typically the project manager).
- End date of entries.
- In specific cases, special logbooks may be required (e.g., waterproof paper for stormwater monitoring).

The first few (approximately three) pages of the logbook will be reserved for a table of contents (TOC). Mark the first page with the heading and enter the following:

**Table of Contents**

| Date/Description              | Pages |
|-------------------------------|-------|
| (Start Date)/Reserved for TOC | 1-3   |

The remaining pages of the table of contents will be designated as such with "TOC" written on the top center of each page. The table of contents should be completed as activities are completed and before placing the logbook in the records file.

**5.2 Operation**

Requirements that must be followed when using a logbook:

- Record work, observations, quantities of materials, calculations, drawings, and related information directly in the logbook. If data collection forms are specified by an activity-specific plan, this information does not need to be duplicated in the logbook. However, any forms used to record site information must be referenced in the logbook.
- Do not start a new page until the previous one is full or has been marked with a single diagonal line so that additional entries cannot be made. Use both sides of each page.
- Do not erase or blot out any entry at any time. Indicate any deletion by a single line through the material to be deleted. Initial and date each deletion. Take care to not obliterate what was written previously.
- Do not remove any pages from the book.
- All entries must be clearly written and legible.

Specific requirements for field logbook entries include:

- Initial and date each page.
- Sign and date the final page of entries for each day.
- Initial and date all changes.
- Multiple authors must sign out the logbook by inserting the following:  
Above notes authored by:
  - (Sign name)
  - (Print name)
  - (Date)
- A new author must sign and print his/her name before additional entries are made.
- Draw a diagonal line through the remainder of the final page at the end of the day.
- Record the following information on a daily basis:
  - Date and time
  - Name of individual making entry
  - Names of field team and other persons onsite
  - Description of activity being conducted including station or location (i.e., well, boring, sampling location number) if appropriate
  - Weather conditions (i.e., temperature, cloud cover, precipitation, wind direction, and speed) and other pertinent data
  - Level of personal protection used
  - Serial numbers of instruments
  - Equipment calibration information
  - Serial/tracking numbers on documentation (e.g., carrier air bills)

**Field Logbook Content and Control**

SOP 4-1

Revision: 8

Date: February 2015

Entries into the field logbook shall be preceded with the time (written in military units) of the observation. The time should be recorded frequently and at the point of events or measurements that are critical to the activity being logged. All measurements made and samples collected must be recorded unless they are documented by automatic methods (e.g., data logger) or on a separate form required by an operating procedure. In these cases, the logbook must reference the automatic data record or form.

At each station where a sample is collected or an observation or measurement made, a detailed description of the location of the station is required. Use a compass (include a reference to magnetic declination corrections), scale, or nearby survey markers, as appropriate. A sketch of station location may be warranted. All maps or sketches made in the logbook should have descriptions of the features shown and a direction indicator. It is preferred that maps and sketches be oriented so that north is toward the top of the page. Maps, sketches, figures, or data that will not fit on a logbook page should be referenced and attached to the logbook to prevent separation.

Other events and observations that should be recorded include:

- Changes in weather that impact field activities.
- Deviations from procedures outlined in any governing documents. Also record the reason for any noted deviation.
- Problems, downtime, or delays.
- Upgrade or downgrade of personal protection equipment.
- Visitors to the site.

**5.3 Post-Operation**

To guard against loss of data as a result of damage or disappearance of logbooks, completed pages shall be periodically photocopied or scanned (weekly, at a minimum) and forwarded to the field or project office. Other field records shall be photocopied or scanned and submitted regularly and as promptly as possible to the office. When possible, electronic media such as flash drives or disks should be copied and forwarded to the project office. Follow the records control procedures specified in the site-specific plan.

At the conclusion of each activity or phase of site work, the individual responsible for the logbook will ensure that all entries have been appropriately signed and dated and that corrections were made properly (single lines drawn through incorrect information, then initialed and dated). The completed logbook shall be submitted to the records file.

**6.0 Restrictions/Limitations**

Field logbooks constitute the official record of onsite technical work, investigations, and data collection activities. Their use, control, and ownership are restricted to activities pertaining to specific field operations carried out by CDM Smith personnel and their subcontractors. They are documents that may be used in court to indicate dates, personnel, procedures, and techniques employed during site activities. Entries made in these logbooks should be factual, clear, precise, and nonsubjective. Field logbooks, and entries within, are not to be used for personal use.

**7.0 References**

EPA 2007. Contract Laboratory Program Guidance for Field Samplers. Office of Superfund Remediation and Technology Innovation. OSWER 9240.0-44. EPA 540-R-07-06. July.

US EPA. 2014. Region 4. The Field Branches Quality System and Technical Procedures, Soil Sampling. SESDPROC-010-R5. May.

## Photographic Documentation of Field Activities

SOP 4-2

Revision: 9

Date: February 2015

Approved:

  
 Signature

Technical Review:

Robert R. Alexander

### 1.0 Objective

The purpose of this technical standard operating procedure (SOP) is to provide standard guidelines and methods for photographic documentation, which include digital photography and recordings of field activities and site features (geologic formations, core sections, lithologic samples, water samples, general site layout, etc.). This SOP is intended for circumstances when formal photographic documentation is required. Based on project requirements, it may not be applicable for all photographic activities.

### 2.0 Background

#### 2.1 Definitions

**Photographer** - A photographer is the camera operator of digital photography or recordings whose primary function with regard to this SOP is to produce documentary or data-oriented visual media.

**Identifier Component** - Identifier components are visual components used within a photograph such as visual slates, reference markers, and pointers.

**Standard Reference Marker** - A standard reference marker is a reference marker that is used to indicate a feature size in the photograph and is a standard length of measure, such as a ruler, meter stick, etc. In limited instances, if a ruled marker is not available or its use is not feasible, it can be a common object of known size placed within the visual field and used for scale.

**Slates** - Slates are blank white index cards, marker boards, or paper used to present information pertaining to the subject/procedure being photographed. Letters and numbers on the slate will be bold and written with black indelible marking pens.

**Arrows and Pointers** - Arrows and pointers are markers/pointers used to indicate and/or draw attention to a special feature within the photograph.

**Contrasting Backgrounds** - Contrasting backgrounds are backdrops used to lay soil samples, cores, or other objects on for clearer viewing and to delineate features.

**Date Stamp** - A date stamp is a built-in feature that will record the date and time directly on a digital image or recording.

#### 2.2 Associated Procedures

- SOP 4-1, *Field Logbook Content and Control*

#### 2.3 Discussion

Digital photographs and recordings made during field investigations are used as an aid in documenting and describing site features, sample collection activities, equipment used, and possible lithologic interpretation. This SOP is designed to illustrate the format and desired placement of identifier components, such as visual slates, standard reference markers, and pointers. The use of a photographic logbook and standardized entry procedures are also outlined. These procedures and guidelines will minimize potential ambiguities that may arise when viewing the images or recordings and ensure the representative nature of the photographic documentation.

### 3.0 General Responsibilities

**Field Team Leader** - The field team leader (FTL) is responsible for ensuring that the format and content of photographic documentation are in accordance with this procedure. The FTL is responsible for directing the photographer to specific situations, site features, or operations that the photographer will be responsible for documenting.

## Photographic Documentation of Field Activities

SOP 4-2

Revision: 9

Date: February 2015

**Photographer** - The photographer shall seek direction from the FTL and regularly discuss the visual documentation requirements and schedule. The photographer is responsible for maintaining a logbook per Sections 5.1, 5.2.4, and 5.3.1 of this SOP. Responsibilities will be defined in the project sampling plan.

**Note:** Responsibilities may vary from site to site. Therefore, all field team member responsibilities shall be defined in the field plan or site/quality assurance project plan (QAPP).

### 4.0 Required Equipment

A general list of equipment that may be used:

- Digital camera and appropriate storage media
- Extra batteries for camera
- Digital video camera and appropriate storage media (e.g., SD card)
- Logbook
- Indelible black or blue ink pen
- Standard reference markers (e.g. ruler)
- Slates or marker boards
- Arrows or pointers
- Contrasting backgrounds
- 
- 
- 

### 5.0 Procedures

#### 5.1 Documentation

Documentation requirements for digital photographs and recordings should be specified in the site-specific plan. Otherwise, a commercially available, bound logbook will be used to log and document photographic activities. Review SOP 4-1, *Field Logbook Content and Control* and prepare all supplies needed for logbook entries.

**Note:** A separate photographic logbook is not required. A portion of the field logbook may be designated as the photographic log and documentation section.

#### Field Health and Safety Considerations

There are no hazards that an individual will be exposed to specific to photographic documentation. However, site-specific hazards may arise depending on location or operation. Personal protective equipment used in this operation will be site-specific and dictated through requirements set by the site safety officer, site health and safety plan, and/or prescribed by the CDM Smith Corporate Health and Safety Program. The photographer should contact the site safety officer for health and safety orientation before commencing field activities. The site health and safety plan must be read before entry to the site, and all individuals must sign the appropriate acknowledgement that this has been done.

The photographer should be aware of any potential physical hazards while photographing the subject (e.g., traffic, low overhead hazard, edge of excavation).

#### 5.2 Operation

##### 5.2.1 General Photographic Activities in the Field

The following sections provide general guidelines that should be followed to visually document field activities and site features using digital still and video cameras. Listed below are general suggestions that the photographer should consider when performing activities under this SOP:

- The photographer should be prepared to make a variety of shots, from close-up to wide-angle. Many shots will be repetitive in nature or format, especially close-up site feature photographs. Consideration should therefore be given to designing a system, camera settings, or technique that will provide a reliable repetition of performance.



## Photographic Documentation of Field Activities

SOP 4-2

Revision: 9

Date: February 2015

- No preference of digital storage medium is specified and is left to the discretion of the photographer.
- Digital cameras have multiple photographic quality settings. A camera that obtains a higher resolution (quality) has a higher number of pixels and will store a fewer number of photographs per digital storage medium. Project resolution requirements should be determined prior to implementing field work.

### 5.2.2 General Guidelines for Still Photography

#### Caption Information

Unless otherwise specified in a site-specific plan, all still photographs will have a full caption added after the images are downloaded on a photo log sheet. The caption should contain the following information:

- Photograph sequence number
- Date and time
- Photographer
- Description of activity/item shown (e.g., name of facility/site, specific project name, project number)
- Direction (if applicable)

When directed by the sampling plan, a standard reference marker should be used in all documentary visual media. While the standard reference marker will be predominantly used in close-up feature documentation, inclusion in all scenes should be considered.

Digital images should be downloaded at least once each day to a personal computer; the files should be in either "JPEG" or "TIFF" format. Files should be renamed at the time of download to correspond to the logbook or as directed in the site-specific plan. It is recommended the electronic files be copied to a compact disc for backup.

#### Close-Up and Feature Photography

When directed by the sampling plan, close-up photographs should include a standard reference marker of appropriate size as an indication of the feature size and contain a slate or marker board marked with the site name and any identifying label, such as a well number or core depth, that clearly communicates to the viewer the specific feature being photographed.

Feature samples, core pieces, and other lithologic media should be photographed as soon as possible after they have been removed from their in situ locations. This enables a more accurate record of their initial condition and color. When directed by the sampling plan, include a standard reference color strip (color chart such as Munsell Soil Color Chart) within the scene. This is to be included for the benefit of the viewer of the photographic document and serves as a reference aid to the viewer for formal lithologic observations and interpretations.

#### Site Photography

Site photography, in general, will consist predominantly of medium- and wide-angle shots. If required by the sampling plan, a standard reference marker should be placed adjacent to the feature or, when this is not possible, within the same focal plane.

While it is encouraged that a standard reference marker and slate/marker board be included in the scene, it is understood that situations will arise that preclude their inclusion within the scene. This will be especially true of wide-angle shots. In such a case, the image number shall be entered in the photographic logbook along with other information pertinent to the scene.

### 5.2.3 General Photographic Documentation Using Digital Video Cameras

Documentary digital recordings of field activities may include an audio slate for all scenes. At the beginning of each video session, an announcer will recite the following information: date, time (in military units), photographer, site ID number, and site location. This oral account may include any additional information clarifying the subject matter being recorded.

## Photographic Documentation of Field Activities

SOP 4-2

Revision: 9

Date: February 2015

A standard reference marker may be used when taking close-up shots of site features with a video camera. The scene may also include a caption/slate. It should be placed adjacent and parallel to the feature being photographed.

It is recommended that a standard reference marker and slate/marker board be included in all scenes. The caption information is vital to the value of the documentary visual media and should be included. If it is not included within the scene, it should be placed before the scene.

Original video recordings will not be edited. This will maintain the integrity of the information contained on the videotape or DVD. If editing is desired, a working copy of the original video recording can be made.

A digital recording filename should be created with the appropriate identifying information (project name, project number, date, location, etc.).

### 5.2.4 Photographic Documentation

If required by the site-specific plan, photographic activities must be documented in a photographic logbook or in a section of the field logbook. The photographer will be responsible for making proper entries.

In addition to following the technical standards for logbook entry as referenced in SOP 4-1, the following information should be maintained in the appropriate logbook:

- Photographer name.
- Sequential tracking number for each photograph taken (the camera-generated number may be used).
- Date and time (military time).
- Location.
- A description of the activity/item photographed.
- If needed, a description of the general setup, including approximate distance between the camera and the subject, may be recorded in the logbook.
- Record as much other information as possible to assist in the identification of the photographic document.

### 5.3 Post Operation

The photographer shall be responsible for downloading image files or recordings to the project files.

As required, the photographer(s) will ensure that the appropriate logbook has been completely filled out and maintained as outlined in SOP 4-1. Images and recordings will be handled according to contract records requirements. The project manager will ensure their proper distribution. Completed pages of the appropriate logbook will be copied weekly and submitted to the project files.

## 6.0 Restrictions/Limitations

This document is designed to provide a set of guidelines to ensure that an effective and standardized program of visual documentation is maintained.

It is not within the scope of this document to provide instruction in photographic procedures, nor is it within the scope of this document to set guidelines for presentation or "show" photography.

The procedures outlined herein are general by nature. The photographer is responsible for specific operational activity or procedure described in site-specific plans. Questions concerning specific procedures or requirements should be directed to the project manager or FTL.

**Note:** Some sites do not permit photographic documentation. Check with the site contact for any restrictions.

## Photographic Documentation of Field Activities

SOP 4-2

Revision: 9

Date: February 2015

### 7.0 References

U. S. Army Corps of Engineers. 2001. *Requirements for the Preparation of Sampling and Analysis Plans*, EM 200-1-3. Appendix F. February.

U. S. Environmental Protection Agency. 1992. National Enforcement Investigations Center. *Multi-Media Investigation Manual*, EPA-330/9-89-003-R. p. 85. Revised March.

\_\_\_\_\_. 2013. Region 4. The Field Branches Quality System and Technical Procedures, Soil Sampling. SESDPROC-005-R2. January.

**Well Development and Purging**

SOP 4-3

Revision: 7

Date: February 2015

Approved:

  
Signature

Technical Review:

David Schroeder

**1.0 Objective**

The purpose of this technical standard operating procedure (SOP) is to define the procedural requirements for well development and purging.

**2.0 Background**

Monitoring wells are developed to repair damage to the formation caused by drilling activities and to settle and remove fines from the filter pack. Wells shall not be developed for at least 24 to 48 hours after completion when a cement bentonite grout is used to seal the annular space; however, wells may be developed before grouting if conditions warrant. Wells are purged immediately before groundwater sampling to remove stagnant water and to sample representative groundwater conditions. Wells shall be sampled within 3 hours of purging (optimum) to 24 hours after purging (maximum, for low recharge conditions).

**2.1 Associated Procedures**

- SOP 1-6, *Water Level Measurement*
- SOP 4-1, *Field Logbook Content and Control*
- SOP 4-5, *Field Equipment Decontamination at Nonradioactive Sites*

**3.0 General Responsibilities**

**Site Manager** - The site manager is responsible for ensuring that field personnel are trained in the use of this procedure and for verifying that development and purging are carried out in accordance with this procedure.

**Field Team Leader** - The field team leader is responsible for complying with this procedure.

**Note:** Responsibilities may vary from site to site. Therefore, all field team member responsibilities shall be defined in the field plan or site-/project-specific quality assurance plan.

**4.0 Required Equipment****4-1 General**

- Pump, pump tubing, or bailer and rope or wire line
- Power source (e.g., generator), if required
- Electronic water-level meter
- Temperature, conductivity, pH, and turbidity meters
- Personal protective equipment as specified in the site-specific health and safety plan
- Decontamination supplies, as required, according to SOP 4-5, *Field Equipment Decontamination at Nonradioactive Sites*
- Disposal drums, if required
- Photoionization detector (PID) or equivalent as specified in site-specific health and safety plan

**5.0 Procedures****5.1 Well Development**

The following steps must be followed when developing wells:

1. Review site-specific health and safety plan and project plans before initiating sampling activity.
2. Don personal protective clothing and equipment as specified in the site-specific health and safety plan.

**Well Development and Purging**

SOP 4-3

Revision: 7

Date: February 2015

3. Open the well cover and check condition of the wellhead, including the condition of the surveyed reference mark, if any.
4. Monitor the air space at the wellhead, using a PID or equivalent, as soon as well cover is removed according to health and safety requirements.
5. Determine the depth to static water level and depth to bottom of the well (SOP 1-6).
6. Prepare the necessary equipment for developing the well. There are a number of techniques that can be used to develop a well. Some of the more common methods are bailing, overpumping, backwashing, mechanical surging, surge and pump, wire brush, swabbing, and high-velocity jetting. All of these procedures are acceptable; however, final approval of the development method rests with the appropriateness of a specific method to the geologic conditions, well type and approved work plans, field sampling plans, etc.
7. For screened intervals longer than 10 feet (3 meters [m]), develop the well in 2- or 3-foot (0.75- or 1-m) intervals from bottom to top. This will ensure proper packing of the filter pack.
8. Continue well development until produced water is clear and free of suspended solids, as determined by a turbidity meter or when pH, conductivity, and temperature have stabilized. Record pertinent data in the field logbook and on appropriate well development forms. Remove the pump assembly or bailers from the well, decontaminate (if required), and clean up the area. Lock the well cover before leaving. Containerize and/or dispose of development water as required by the site-specific plans.

**5.2 Volumetric Method of Well Purging**

The following steps shall be followed when purging a well by the volumetric method:

1. Review site-specific health and safety plan and project plans before initiating well purging activity.
2. Don personal protective clothing and equipment as specified in the site-specific health and safety plan.
3. Open the well cover and check condition of the wellhead, including the condition of the surveyed reference mark, if any.
4. Monitor the air space at the wellhead, using a PID or equivalent, as soon as well cover is removed according to health and safety requirements.
5. Determine the depth to static water level and depth to bottom of well casing according to SOP 1-6, *Water Level Measurement*. Calculate the volume of water within the well bore using the following formula (or equivalent):

$$7.4805 \left[ \frac{D^2 \pi}{4} \right] dH = \text{volume (in gallons)}$$

where

D = casing diameter in feet. (**Note:** This equation is used for grouted wells with short screens. For wells with long screens and/or ungrouted wells, the D = borehole diameter in feet).

dH = the distance from well bottom to static water level in feet.

$\pi = 3.1416$ .

Alternatively, the volume may be determined using a casing volume per foot factor for the appropriate diameter well, similar to that in Table 1. The water level is subtracted from the total depth, providing the length of the water column. This length is multiplied by the factor in Table 1 corresponding to the appropriate well diameter, providing the amount of water, in gallons, contained in the well.

**Well Development and Purging**

SOP 4-3

Revision: 7

Date: February 2015

**TABLE 1**  
**WELL CASING DIAMETER vs. VOLUME**

| WELL CASING DIAMETER (inches) vs. VOLUME (gals.)/FEET of WATER |            |
|--|------------|
| CASING   | GALLONS/FT |
| 1  | 0.041      |
| 2  | 0.163      |
| 3  | 0.367      |
| 4  | 0.653      |
| 5  | 1.02       |
| 6  | 1.469      |
| 7  | 1.999      |
| 8  | 2.611      |
| 9  | 3.305      |
| 10   | 4.08       |
| 11   | 4.934      |
| 12   | 5.875      |

**Note:** Record all data and calculations in the field logbook.

6. Prepare the pump and tubing, or bailer, and lower it into the casing.
7. Remove the number of well volumes specified in the site-specific plans. Generally, three to five well volumes will be required. Conductivity, pH, temperature, and turbidity shall be measured and recorded. Purging shall continue until the field parameters have stabilized. Groundwater quality parameters are considered stable when three consecutive readings are within  $\pm 0.1$  for pH,  $\pm 3$  percent for conductivity,  $\pm 10$  mv for redox potential (ORP), and  $\pm 10$  percent for turbidity if greater than 10 NTU, in accordance with site-specific plans. Efforts shall be made to get turbidity below 10 NTU, especially if groundwater samples are to be collected for metals or PCB analyses.
8. In low recharge aquifers, the following steps shall be followed: (1) If the initial water level is less than 10 feet above the top of the screen, then purge to dryness and allow sufficient recharge to collect samples. (2) If initial water level in the well is more than 10 feet above the top of the screen, then care shall be taken to prevent the dewatering of the screened interval. (3) Continue purging until the water level is between 1 and 5 feet above the top of the screen. (4) Allow well to recharge then continue purging until at least 1 full initial well volume has been purged. (5) Record pertinent data in the field logbook.
9. Groundwater sampling shall be performed immediately upon completion of purging (unless time for recharge is required for low-recharge wells) using the same equipment that was used for purging. Unfiltered samples shall be collected first, beginning with volatile organic compounds (VOCs). After all unfiltered samples have been collected, a 0.45 micron in-line filter shall be installed in the discharge line for collection of filtered samples, if required.
10. After sampling activities have been completed, remove the pump assembly or bailer from the well, decontaminate it (if required), and clean up the site. Lock the well cover before leaving. Containerize and/or dispose of development water as required by the site-specific plan.

**5.3 Indicator Parameter Method of Well Purging**

1. Review site-specific health and safety plan and project plans before initiating well purging activity.
2. Don personal protective clothing and equipment as specified in the site-specific health and safety plan.
3. Open the well cover and check the condition of the wellhead, including the condition of the surveyed reference mark, if any.

**Well Development and Purging**

SOP 4-3

Revision: 7

Date: February 2015

4. Monitor the air space at the wellhead, using a PID or equivalent, as soon as well cover is removed according to health and safety requirements.
5. Determine the depth to static water level and depth to bottom. Set up surface probe(s), (e.g., pH, conductivity) at the discharge orifice or dedicated probe port of the pump assembly or within the flow-through chamber. Allow probe(s) to equilibrate according to manufacturer's specifications. Record the equilibrated readings in the field logbook.
6. Assemble the pump and tubing and lower into the casing.
7. Begin pumping or bailing the well. Record indicator parameter readings for every 5 minutes or purge volume, whichever is sooner. Maintain a record of the approximate volumes of water produced. Care shall be taken to minimize drawdown (0 to 0.2 feet).
8. Continue pumping or bailing until indicator parameter readings remain stable within  $\pm 0.1$  for pH,  $\pm 3$  percent for conductivity,  $\pm 10$  mv for redox potential (ORP), and  $\pm 10$  percent for turbidity if greater than 10 NTU for three consecutive recording intervals and a minimum of 1 well volume is removed, or in accordance with site-specific plans. Purging shall continue until the discharge stream is clear or turbidity becomes asymptotic-low or meets project requirements.
9. For a low recharge aquifer, follow the guidelines of Section 5.2, Paragraph 7.
10. Groundwater sampling shall be performed immediately upon completion of purging (unless time for recharge is required for low-recharge wells) using the same equipment that was used for purging. Unfiltered samples shall be collected first, beginning with VOCs. After all unfiltered samples have been collected, a 0.45 micron in-line filter shall be installed in the discharge line for collection of filtered samples, if required.
11. Remove the pump assembly or bailer from the well, decontaminate (if required), and clean up the site. Lock the well cover before leaving. Containerize and/or dispose of development water as required by the site-specific plans.

**6.0 Restrictions/Limitations**

Where flammable, free, or emulsified product is expected, or known to exist on or in groundwater, use intrinsically safe electrical devices only and place portable power sources (e.g., generators) 50 feet (15 m) or further from the wellhead and disposal drums.

**7.0 References**

American Society for Testing and Materials. 2005. Designation: D 5521, *Standard Guide for Development of Groundwater Monitoring Wells in Granular Aquifers*, Rev. 5, November.

U. S. Army Corps of Engineers. 1998. *Monitoring Well Design, Installation, and Documentation at Hazardous Toxic, and Radioactive Waste Sites, EM 1110-1-4000*, Chapter 6. November 1.

U. S. Environmental Protection Agency, Region III, 1997. *Low-Flow Purging and Sampling of Groundwater Monitoring Wells*, Bulletin No. QAD023, Philadelphia, Pennsylvania. October.

U. S. Environmental Protection Agency. 2002. *Groundwater Sampling Guidelines for Superfund and RCRA Project Managers*. Ground Water Forum Issue Paper, EPA 542-S-02-001, OSWER, Technology Innovative Office, Washington, D.C. May.

U. S. Environmental Protection Agency, Region IX, 2004. *Groundwater Well Sampling, Field Sampling Guidance Document #1220*.

## Design and Installation of Monitoring Wells in Aquifers

SOP 4-4  
Revision: 8  
Date: February 2015

Approved:

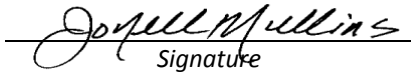
  
Signature

Technical Review:

Michael Valentino

### 1.0 Objective

The purpose of this technical standard operating procedure (SOP) is to provide guidelines for the installation of groundwater monitoring wells. These guidelines will help to produce consistency of approach in the design and installation of monitoring wells. Individual installations will probably vary in some respects since they may encounter differing hydrogeologic conditions.

### 2.0 Background

#### 2.1 Definitions

**Monitoring Well Installation** - The act of installing well casing, screen, filter pack, bentonite seal, grout, and other specified materials in a borehole to construct a complete monitoring well.

#### 2.2 Associated Procedures

- SOP 3-5, *Lithologic Logging*
- SOP 4-1, *Field Logbook Content and Control*
- SOP 4-2, *Photographic Documentation of Field Activities*
- SOP 4-3, *Well Development and Purging*
- SOP 4-5, *Field Equipment Decontamination at Nonradioactive Sites*

#### 2.3 Discussion

This SOP is intended to cover the installation of monitoring wells for use in conducting a variety of environmental investigations. It is intended to be a general guideline listing the types of materials and methods to be considered when a well is installed. Materials are not specified in detail since it is likely there will be wide variability required to meet the needs of individual site conditions or specific clients. Ideally, the well shall not alter the medium that is being sampled.

### 3.0 General Responsibilities

**Site Manager** - Translates client's requirements into technical direction of project. Sets technical criteria, reviews and approves technical progress, and ensures that all participating personnel have proper training. **Note:** Other titles such as project manager may be used.

**Field Team Leader (FTL)** - Supervises field operations. Ensures that all necessary equipment including safety equipment is available and functioning properly before project operations begin. Ensures that all necessary personnel are mobilized on time. Maintains daily log of activities each work day.

**Field Geologist** - Collects and maintains data and completes Monitoring Well Construction Forms. Coordinates and consults with site manager on decisions relative to unexpected encounters during well installation and deviation from this SOP. Directs overall activities of drill and support subcontractors.

**Drilling Subcontractor** - Provides necessary personnel, equipment, and services to meet terms of the contract.

**Note:** Responsibilities may vary from site to site. Therefore, all field team member responsibilities shall be defined in the field plan or site-/project-specific quality assurance plan.



## Design and Installation of Monitoring Wells in Aquifers

SOP 4-4

Revision: 8

Date: February 2015

### 4.0 Required Equipment and Materials

#### 4.1 Required Equipment

- Field logbook
- Monitoring Well Construction Forms
- Measuring tape

#### 4.2 Required Construction Materials

**General** - The materials that are used in the construction of a monitoring well and that come in contact with the groundwater shall not measurably alter the chemical quality of a groundwater sample. The well casing and well screen shall be steam cleaned (if appropriate for the selected material) before well installation or certified clean from the manufacturer and delivered to the site in protective wrapping. If required by the site specific plans, samples of the cleaning water, drilling fluids, filter pack, annular seal, and mixed grout may be retained to be analyzed if groundwater contamination as the result of well installation is suspected. If required, these samples can serve as quality control checks until the completion of at least one round of groundwater quality sampling and analysis.

**Water** - Water, which may be used in the well completion process, shall be obtained from a source that does not contain constituents that could compromise the integrity of the well installation. If required by the site specific plans, a certificate of analysis shall be provided with the water, or a sample of the water shall be analyzed and documented as contaminant-free.

**Surface (Isolation) Casing** - Surface, or isolation, casing may be required to isolate an upper aquifer while drilling and installing deep wells. The isolation casing usually consists of black steel or polyvinyl chloride (PVC). Surface casings shall be large enough to allow a minimum annular space of 2 inches between it and the well casing. Segments of black steel casings are typically welded together as the casing is lowered down the borehole. PVC isolation casings are either flush-threaded or have a bell shape at one end so that sections slip together and are held with small stainless steel screws. Casings shall be grouted in place and allowed to set for 12 to 24 hours before advancing the borehole below the surface casing.

**Well Screen** - The well screen shall be new and composed of materials most suited for the environment being monitored. The screened interval shall be plugged at the bottom. The plug shall be of the same material as the bottom section of screen and shall be securely attached, making a positive seal. This assembly must have the capability to withstand well installation and development stresses without becoming dislodged or damaged. The length of the well screen slotted area shall be appropriate for the interval to be monitored including some allowance for changes in elevation of the water table. Before installation, the casing string and associated equipment shall be cleaned with steam or high-pressure hot water, if not certified cleaned. Well screens shall be stainless steel or PVC, as appropriate. Fluoropolymer materials may be substituted if necessary because of the potential for incompatible chemical reactions between contaminants and the stainless steel screen, or if stainless steel constituents are possible site contaminants. The minimum inside diameter of the well screen shall be chosen based on the particular application. Well screens shall be flush threaded per American Society for Testing and Materials (ASTM) standards. Glued or solvent-welded joints may not be used since glues and solvents may alter the chemistry of the water samples.

The slot size of the well screen shall be determined relative to the grain-size analysis of the stratum to be monitored and the gradation of the filter pack material. In granular, noncohesive, strata that falls in easily around the screen, filter packs may not be necessary. In these cases of natural development, the slot size of the well screen is to be determined using the grain size of the surrounding strata. The slot size and arrangement shall retain at least 90 percent of the filter pack.

**Casing** - The well casing will be PVC, stainless steel, or some other appropriate material and will extend from the screen to the surface. The type of casing and wall thickness shall be adequate to withstand the forces of installation. Several different casing sizes may be required depending on the subsurface geologic conditions. The diameter of the casing for filter packed wells shall be selected so that a minimum annular space of 2 inches is maintained between the casing and the borehole wall. The diameter of the casings in multi-cased wells shall be selected so that a minimum annular space of 2 inches is maintained between casing strings and between the outer casing and the borehole (e.g., a 2-inch-diameter well screen will require first setting a 6-inch-diameter casing in a 10-inch-diameter boring). Under difficult drilling conditions (collapsing soils, rock, or cobbles), it may be necessary to advance temporary casing. Under these conditions, a smaller space may be maintained. The ends of each casing section shall be flush-threaded.

## Design and Installation of Monitoring Wells in Aquifers

SOP 4-4

Revision: 8

Date: February 2015

**Primary Filter Pack** - The primary filter pack (sand or gravel pack) consists of a clean, well-sorted, rounded granular material of selected grain size and gradation that is installed in the annulus between the screened interval and the borehole wall. The filter pack may be installed along the screened interval using a tremie pipe from the total depth of the well to the designated distance above the top of the screened interval. A filter pack material mostly consisting of siliceous, rather than calcareous, particles is preferred. Select the grading of the filter pack on the basis of the layer of finest material to be screened. A minimum filter pack thickness shall be between 2 to 3 inches and generally shall never be greater than 8 inches. The filter pack shall extend at least 2 to 3 feet above the screened interval or more depending on the screen length to provide for filter pack settlement.

**Transition Sand** - A layer of fine to very fine sand may be placed on top of the primary filter pack before emplacement of the bentonite seal. The sand shall be of sufficient thickness to prevent bentonite from penetrating to the vicinity of the well screen during placement of the bentonite seal.

**Annular Sealants** - The materials used to seal the annulus may be prepared as a slurry or used unmixed in a dry pellet form. Sealants shall be selected for compatibility with local geologic, hydrogeologic, climatic, and human-induced conditions anticipated to occur during the life of the well.

**Grout** - The grout backfill that is placed above the bentonite annular seal shall be a liquid slurry consisting of water, bentonite grout of Volclay or equivalent quality, and portland cement. Bentonite-based grouts are typically used when a more flexible grout is desired (i.e., freeze-thaw). Cement-based grout provides a more rigid installation. A typical bentonite grout mixture is 1 to 1.25 pounds bentonite to 2 pounds of Type I portland cement per gallon of water. Cement-based grout is typically 6 to 7 gallons of water per 94 pound bag of Type I portland cement and 2.7 percent bentonite powder.

**Bentonite** - Bentonite shall be powdered or pelletized sodium montmorillonite furnished in sacks or buckets from a commercial source and free of impurities that adversely impact water quality in the well. The diameter of pellets selected for monitoring well construction shall be less than one-fifth the width of the annular space into which they are placed to reduce the potential for bridging. Pellets are typically used for placing annular seals, and powdered bentonite is used for mixing in grout slurry.

**Cement** - Each type of cement has slightly different characteristics that may be appropriate under various physical and chemical conditions. Cement shall generally be portland Type I, Type II, or Type I/II as specified in ASTM C 150. Quick-setting cements containing additives are not allowable for use in monitoring well installation. Additives may leach from the cement and influence the chemistry of the groundwater.

**Annular Seal Equipment (Tremie Pipe)** - A tremie pipe is used to inject the annular seals and filter pack. Tremie pipes are typically constructed of PVC or galvanized steel. Associated equipment may include a trough or mixing box and "mud pump" to place the material.

**Protective Casing** - Protective casings are installed on wells placed in overgrown or nontraffic areas. The casings may be made of galvanized steel (or rarely stainless steel) and shall have a lid capable of being secured by a locking device. The inside dimensions of the protective casing shall be at a minimum 4 inches larger than the diameter of the casing to facilitate the installation and operation of sampling equipment. Protective casing shall extend approximately 2 to 3 feet into the ground to anchor it securely. Protective casings are typically set in concrete pads measuring 2 feet x 2 feet to 4 feet x 4 feet and 4 to 6 inches thick depending on client requirements.

**Flush-Mount Protective Covers** - Flush-mount covers (Christy boxes) are installed over wells placed in paved or manicured areas. The covers are typically 8 inches in diameter with a 1-foot galvanized steel skirt and cast iron bolt-down ring and lid. The covers are installed in concrete pads measuring 2 to 3 feet square that are constructed so as to not impede vehicle traffic and sloped from the center toward the edges to prevent infiltration of run-off water.

**Design and Installation of  
Monitoring Wells in Aquifers**

SOP 4-4

Revision: 8

Date: February 2015

**5.0 Procedures****5.1 Drilling Methods**

The actual methods of drilling at a site will vary depending on site conditions. The method to be used at a site shall be stated in the site-specific plans. Deviations from the methods prescribed in these plans shall be approved by the FTL or designee. Typical drilling methods include air rotary or hammer, mud/fluid rotary, roto-sonic, and hollow-stem auger. Drilling with mud or water is least desirable, but the driller shall have the capability to use this method if borehole conditions warrant it. Installation of isolation casing, if required, shall be done by either penetrating the outer casing into the ground by hammer blows or by drilling a borehole. The outer casing shall be set and secured by grouting or other means specified in the site-specific plans. The inner well borehole can then be drilled through the center of the outside casing. The monitoring wells shall be drilled vertical or at an angle if specified in the site-specific plans. The wells shall be drilled to a depth specified in the site-specific plans and may vary based on actual lithologic conditions. The depth to completion shall be approved by the FTL or designee before monitoring well construction. Drillers must prevent grease, oil, and other fluids from the drill rig from coming in contact with the ground around the area of well installation. If air is used during the drilling process (e.g., air rotary), the air supply must be free of oils to prevent introducing contamination to the borehole and groundwater system. This can be accomplished by installing an approved air filter in-line between the air compressor and the air discharge.

Collection of continuous core may be required during borehole drilling. Samples may be collected by several methods depending on project needs and the material being sampled including split-spoon sampler, direct-push, or sonic coring (unconsolidated material), or wire-line coring (bedrock). A description of soil/lithologic materials and drilling observations needs to be recorded on a boring log or in a logbook (SOP 3-5).

**5.2 Monitoring Well Installation****5.2.1 Stable Borehole**

A stable borehole must be constructed before attempting to install the monitoring well. Steps must be taken to stabilize the borehole before attempting installation if the borehole tends to cave or blow-in, or both. Boreholes that are not straight or are partially obstructed shall be corrected before attempting the installations described herein.

Although all monitoring wells will not be completed exactly alike, there are common elements among them. The Monitoring Well Construction Form(s) (Figures 1, 2, 3, and 4 or equivalent) must be completed by the end of the activity with data obtained through the installation process. Modification of the construction and dimensions on the Well Construction Forms may be needed depending on site-specific conditions. The well construction field form shall be reviewed before initiation of drilling activities to ensure that the required data are collected at appropriate times during drilling and installation.

**5.2.2 Well Casing Assembly**

The well screen, casing, and bottom plug shall be either certified clean from the manufacturer or decontaminated according to SOP 4-5.

The casing shall be flush-threaded, using Schedule 40 PVC or other suitable monitoring well casing. No adhesives, cements, or lubricants shall be used during casing make-up or during other drilling and well completion operations. Personnel shall take precautions to ensure that grease, oil, or other contaminants that may alter water samples do not contact any portion of the well casing assembly. As a precaution, personnel shall wear a pair of clean gloves while handling the assembly.

Normally, couplings are tightened by hand; however, steam- or high-pressure-cleaned strap wrenches may also be used. Use pipe wrenches with care as they may scar and weaken the pipe. Precautions shall be taken to prevent damage to the threaded joints during installation.

## Design and Installation of Monitoring Wells in Aquifers

SOP 4-4

Revision: 8

Date: February 2015

### 5.2.3 Setting the Well Screen and Casing Assembly in Fluid Filled Holes

When the well screen and casing assembly is lowered to the predetermined level and held in position, the assembly may require a ballast to counteract the tendency to float in the borehole. Ballasting may be accomplished by continuously filling the casing assembly with contaminant-free water. If fluid ballasts are used, the quantity introduced must be recorded in the field logbook. Alternatively, the casing assembly may be slowly pushed into the fluid in the borehole with the aid of hydraulic rams on the drill rig and held in place as additional sections of casing are added to the column. Care must be taken to secure the casing assembly so that personnel safety is ensured during the installation. For wells greater than 100 feet, the assembly shall be installed straight using centralizers at selected intervals.

The casing shall extend to grade or approximately 2 feet above grade, depending on the intended surface completion, and be capped or covered temporarily to deter entrance of foreign materials during completion operations.

### 5.2.4 Installation of the Primary Filter Pack

Placement of the casing assembly is followed by placing the primary filter pack (consisting of silica sand sized according to the average grain size of the screened formation) into the bottom of the borehole by using a tremie pipe. The primary filter pack is placed in increments as the tremie is gradually raised. The sand pack will be emplaced by the "washdown" gravity method and the depth to the top of the sand pack shall be determined and recorded frequently during the operation to ensure proper placement. The tremie pipe or a weighted line inserted through the tremie pipe can be used to measure the top of the primary filter pack as work progresses. As primary filter pack material is poured into the tremie pipe, potable water is used to help move the sand through the tremie pipe. The quantity of water introduced shall be recorded in a field logbook. If bridging of the primary filter pack occurs, the bridged material shall be broken mechanically before proceeding with the addition of more filter pack material. The depth, volume, and gradation of the primary filter pack will be recorded on the well construction diagram.

Some primary filter pack installations can be accomplished without the use of a tremie pipe. In these instances the filter pack is slowly poured into the borehole from the surface being careful to avoid bridging of the sand as it falls through the water column in the borehole. If this approach is used a weighted tape measure should be lowered into the borehole annulus to measure the increasing height of the filter pack as sand is added to the borehole, making sure to keep the tape measure moving in an up and down motion so the tape does not become buried in the filter pack.

If possible, measuring tape soundings shall be made to ensure the level of the filter pack is in agreement with the calculated volume and that the desired placement is achieved.

If used, temporary casing or auger sections will be withdrawn in increments as the sand pack is emplaced. Care shall be taken to minimize lifting the casing with the withdrawal of the temporary casing/augers. To limit borehole collapse, the temporary casing or hollow-stem auger is usually withdrawn until the lowermost point on the temporary casing or hollow-stem auger is at least 2 feet, but no more than 5 feet, above the filter pack for unconsolidated materials; or at least 5 feet, but no more than 10 feet, for consolidated materials. Ascertain the depth of the sand with an acceptable measuring device or with tremie pipe and verify the thickness of the sand pack. The primary filter pack is typically placed a minimum of 2 feet above the top of the well screen to account for settlement of the filter pack. The volume and depth of the filter pack material shall be measured and recorded on the well construction diagram.

### 5.2.5 Installation of the Bentonite Seal

A minimum 2-foot-thick bentonite seal shall be emplaced on top of the filter pack or transition sand (if used) and is generally emplaced by gravity feed. The bentonite shall be slowly fed into the annulus and carefully monitored to ensure that bridging is not taking place. Time-release pellets coated with a food-grade coating must be used in deep well applications to prevent premature expansion of the bentonite.

## Design and Installation of Monitoring Wells in Aquifers

SOP 4-4

Revision: 8

Date: February 2015

Some clients may require installing the bentonite seal by using a tremie pipe. This type of installation shall be accomplished by washing the bentonite pellets through the tremie pipe with potable water. If the tremie pipe becomes plugged, requiring an increase in pressure to clear it, not less than 20 feet of tremie pipe shall be pulled up to avoid jetting into the sand pack. If the seal is installed above the water level, water shall be added to allow proper hydration of the annular seal (approximately 1 gallon for each linear foot of annular seal). The volume and depth of the bentonite seal material shall be measured and recorded on the well construction diagram.

If possible, measuring tape soundings shall be made to ensure the level of the bentonite seal is in agreement with the calculated volume and that the desired placement is achieved.

### 5.2.6 Grouting the Annular Space

The following procedures apply to both single- and multi-cased monitoring wells. However, it shall be noted that grouting procedures will vary with the type of well design.

A sufficient volume of grout shall be premixed onsite, according to procedure stipulated by the manufacturer, to compensate for unexpected losses and checked against the known volume of annular space to ensure that bridging does not occur during emplacement. The use of alternate grout materials, including grout containing portland cement, may be necessary to control zones of high grout loss. The mixing (and placing) of grout shall be performed with recorded weights and volumes of materials, according to procedures stipulated by the manufacturer. Lumpy grout shall not be used in an effort to prevent bridging within the tremie and the well. Bentonite-based grout of Volclay or equivalent type shall be mixed to the manufacturer's specifications then pumped into place using minimum pump pressure. All additives to grouts shall be evaluated for their effects on subsequent water samples.

Depending upon the well design, grouting may be accomplished using a pressure grouting technique or by gravity feed through a tremie pipe. With either method, grout is introduced in one continuous operation until grout flows out at the ground surface without evidence of drill cuttings or fluid. The grout backfill shall be injected under pressure using a tremie pipe to reduce the possibility of leaving voids in the annular seal and to displace any liquids and drill cuttings that may remain in the annulus.

Grouting shall begin directly above the bentonite seal, after the bentonite has been adequately hydrated. Grout shall be injected using a tremie pipe. The tremie pipe shall be kept full of grout from start to finish with the discharge end of the pipe completely submerged as it is slowly and continuously lifted. Pump pressure shall be kept to a minimum. Approximately 5 to 10 feet of tremie pipe shall remain submerged during grout emplacement. A staged grouting procedure may be considered if the couplings of the selected casing cannot withstand the shear or if there is collapse stress exerted by the full column of grout as it sets. If used, the temporary casing or hollow-stem auger shall be removed in increments (immediately following each lift of grout installation) well in advance of the time when the grout begins to set. The initial grout mixture must be allowed to cure for at least 12 hours, before attempting to refill (top off) the grout to the surface.

The well shall not be developed until the grout sets and cures for the amount of time necessary to prevent a break in the seal between the grout and casing. The amount of time required (generally 24 to 48 hours) will vary with grout content and climate conditions and shall be documented on the well completion diagram along with the volume and depth of grout used to backfill the annular space.

### 5.3 Well Protection

Well protection refers specifically to installations made at or above the ground surface to deter unauthorized entry to the monitoring well, prevent damage, and to prevent surface water from entering the annulus.

The protective casing shall extend from below the frost line (at least 2 feet below grade) to slightly above the well casing top. The protective casing shall be sealed and immobilized in concrete that has been placed around the outside of the protective casing above the set grout backfill. The casing shall be positioned and stabilized in a position concentric with the casing. Clearance (usually 6 inches) shall be maintained between the lid of the protective casing and the top of the casing to accommodate sampling equipment. A ¼-inch-diameter weep hole shall be drilled in the protective casing at the ground surface to permit water to drain out of the annular space. This hole will also prevent water freezing between the well protector and the well casing.

## Design and Installation of Monitoring Wells in Aquifers

SOP 4-4

Revision: 8

Date: February 2015

All materials used shall be documented on the well construction diagram. The monitoring well identification number shall be clearly visible on the inside and outside of the lid of the protective casing and the outside of the protective casing.

A 3-feet x 3-feet x 6-inch-thick concrete pad, sloped to provide water drainage away from the well, may be placed around the installation. Pad size may vary according to site conditions or client specifications. Three to four 2½-inch-diameter concrete-filled steel posts set at least 24 inches below the surface in concrete shall be equally spaced around the well to protect against damage by vehicular traffic for aboveground well completions. The protective casing and steel posts may be primed and painted with rust-resistant yellow paint. The annulus between the well casing and the protective casing may be filled with sand to approximately 1 foot below the top of the well casing to help stabilize the well casing and prevent the loss of tools or equipment in the annular space.

A flush-mounted, traffic-rated casing or vault is typically used for the surface completion of monitoring wells installed in high-use paved or maintained grass (landscaped) areas. The well box cover shall be finished slightly above pavement or ground surface to prevent water entry. A layer of sand or gravel material shall be placed under the casing/vault to allow infiltrating surface water to drain out.

### 5.4 Post Operation

#### 5.4.1 Field

At the conclusion of the monitoring well installation activities, all equipment must be decontaminated (according to SOP 4-5) before moving the equipment to a different work location. All water used in the decontamination of drilling equipment will be contained in an appropriate container, if required in the site-specific plans.

#### 5.4.2 Documentation

The Groundwater Monitoring Well Construction Form (Figures 1, 2, 3, and 4 or equivalent) shall be completed by the FTL or designee at the conclusion of the field activity.

Copies of all field notes, the daily logs, and any completed Groundwater Monitoring Well Construction Forms shall be given to the site manager. These records shall be maintained in the project and document control files. At a minimum, all materials used for construction shall be documented by entering identifying numbers (lot numbers, manufacturer's identification, etc.) in the field logbook. Samples of well materials (including grout, sand, etc.) may be archived if specified in the project plans.

## 6.0 Restrictions and Limitations

None.

## 7.0 References

American Society for Testing and Materials. 2010. Designation: D6725 – 04 (Reapproved 2010), *Standard Practice for Direct-Push Installation of PrePacked Screen Monitoring Wells in Unconsolidated Aquifers*, Rev. 1. November.

\_\_\_\_\_. 2010. Designation: D5092 – 04 (Reapproved 2010)e1, *Standard Practice for Design and Installation of Ground Water Monitoring Wells in Aquifers*, Rev. 4. June.

\_\_\_\_\_. 2010. Designation: D6724 – 04 (Reapproved 2010), *Standard Guide for Installation of Direct-Push Groundwater Monitoring Wells*, Rev. 4. July.

Driscoll, F. G. 1986. *Groundwater and Wells*, 2nd Ed. Johnson Division. St. Paul, Minnesota.

U. S. Army Corps of Engineers. 1998. *Monitoring Well Design, Installation, and Documentation at Hazardous Toxic, and Radioactive Waste Sites*, EM 1110-1-4000. November 1.

**Design and Installation of  
Monitoring Wells in Aquifers**

SOP 4-4  
Revision: 8  
Date: February 2015

**Figure 1**

**Typical Construction Detail of Above-Grade Single-Cased Monitor Well  
(Not to Scale - Shown as an Example Only)**

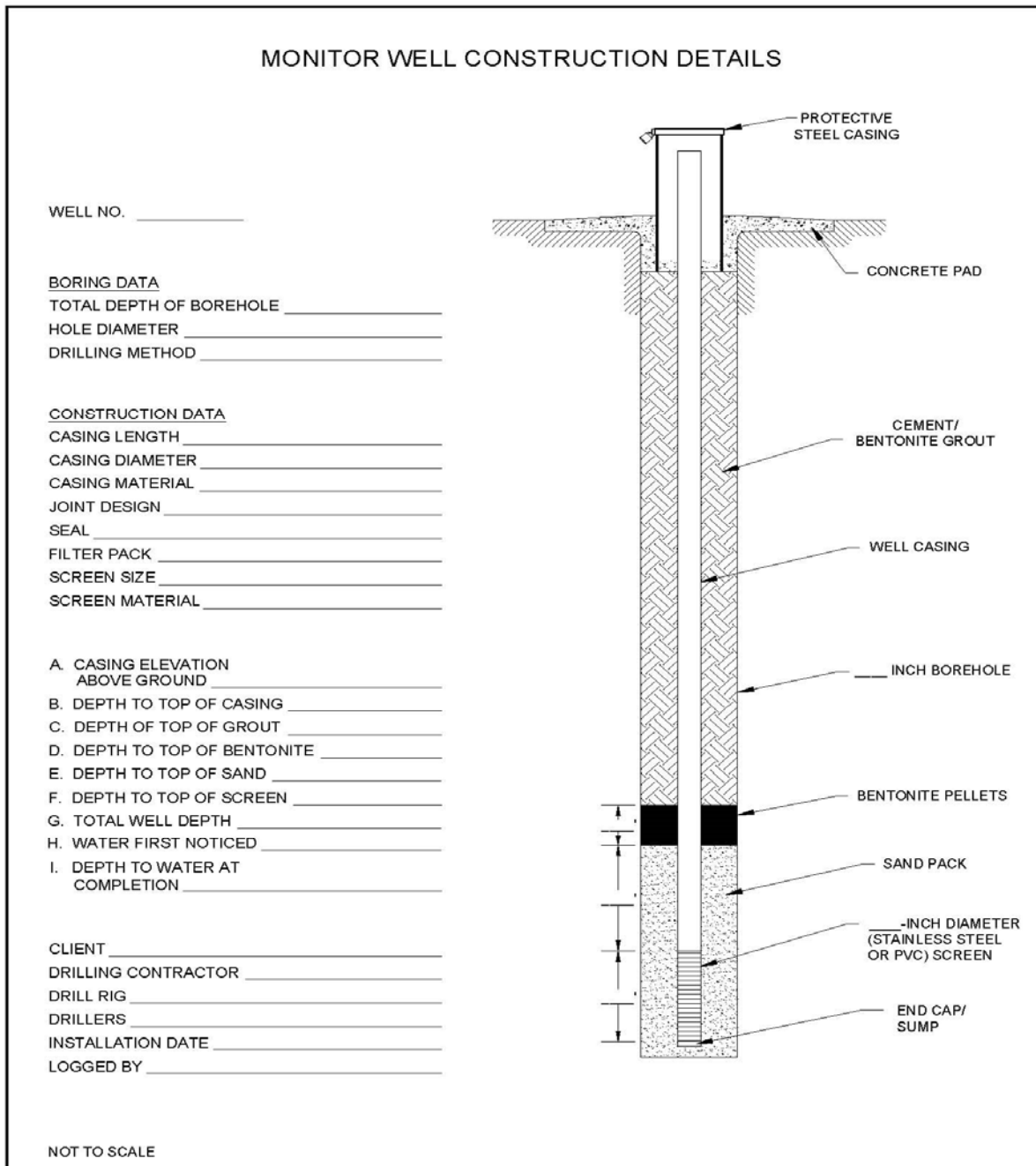

Details of Monitoring Well \_\_\_\_\_  
 Project \_\_\_\_\_  
 Project Location \_\_\_\_\_

**Design and Installation of  
Monitoring Wells in Aquifers**

SOP 4-4  
Revision: 8  
Date: February 2015

**Figure 2**

**Typical Construction Detail of Flush-Mount Single-Cased Monitor Well  
(Not to Scale - Shown as an Example Only)**



**Design and Installation of  
Monitoring Wells in Aquifers**

SOP 4-4  
Revision: 8  
Date: February 2015

**MONITOR WELL CONSTRUCTION DETAILS**

WELL NO. \_\_\_\_\_

BORING DATA

TOTAL DEPTH OF BOREHOLE \_\_\_\_\_  
HOLE DIAMETER \_\_\_\_\_  
DRILLING METHOD \_\_\_\_\_

CONSTRUCTION DATA

CASING LENGTH \_\_\_\_\_  
CASING DIAMETER \_\_\_\_\_  
CASING MATERIAL \_\_\_\_\_  
JOINT DESIGN \_\_\_\_\_  
SEAL \_\_\_\_\_  
FILTER PACK \_\_\_\_\_  
SCREEN SIZE \_\_\_\_\_  
SCREEN MATERIAL \_\_\_\_\_

- A. CASING ELEVATION ABOVE GROUND \_\_\_\_\_
- B. DEPTH TO TOP OF CASING \_\_\_\_\_
- C. DEPTH OF TOP OF GROUT \_\_\_\_\_
- D. DEPTH TO TOP OF FINE SAND \_\_\_\_\_
- E. DEPTH TO TOP OF SAND \_\_\_\_\_
- F. DEPTH TO TOP OF SCREEN \_\_\_\_\_
- G. TOTAL WELL DEPTH \_\_\_\_\_
- H. WATER FIRST NOTICED \_\_\_\_\_
- I. DEPTH TO WATER AT COMPLETION \_\_\_\_\_

CLIENT \_\_\_\_\_  
DRILLING CONTRACTOR \_\_\_\_\_  
DRILL RIG \_\_\_\_\_  
DRILLERS \_\_\_\_\_  
INSTALLATION DATE \_\_\_\_\_  
LOGGED BY \_\_\_\_\_

NOT TO SCALE

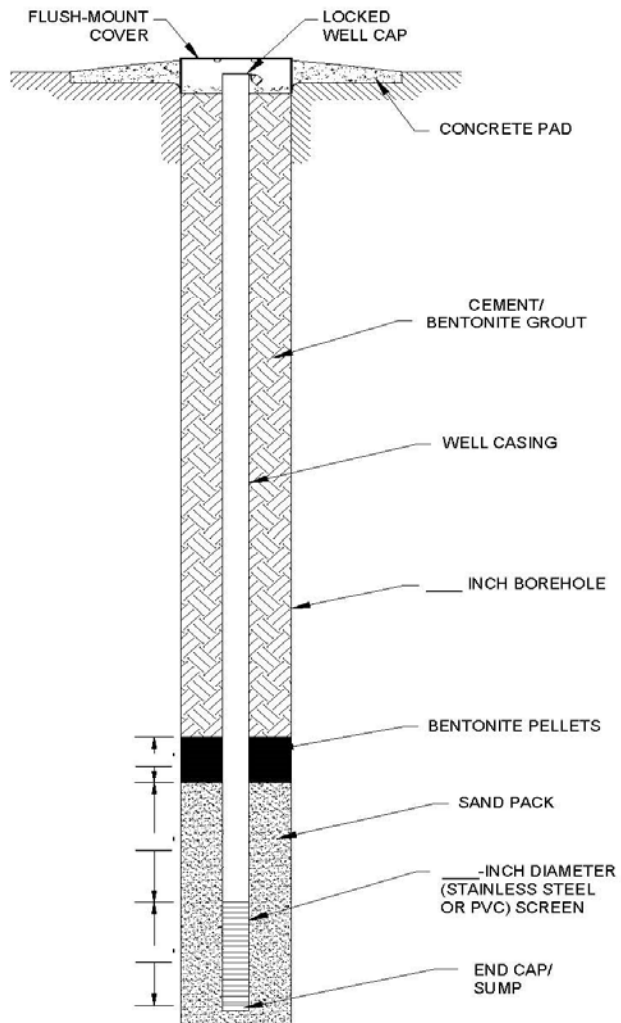

Details of Monitoring Well \_\_\_\_\_

Project \_\_\_\_\_  
Project Location \_\_\_\_\_

**Figure 3**

**Typical Construction Detail of Above-Grade Double-Cased Monitor Well**

**Design and Installation of  
Monitoring Wells in Aquifers**

SOP 4-4  
Revision: 8  
Date: February 2015

(Not to Scale - Shown as an Example Only)

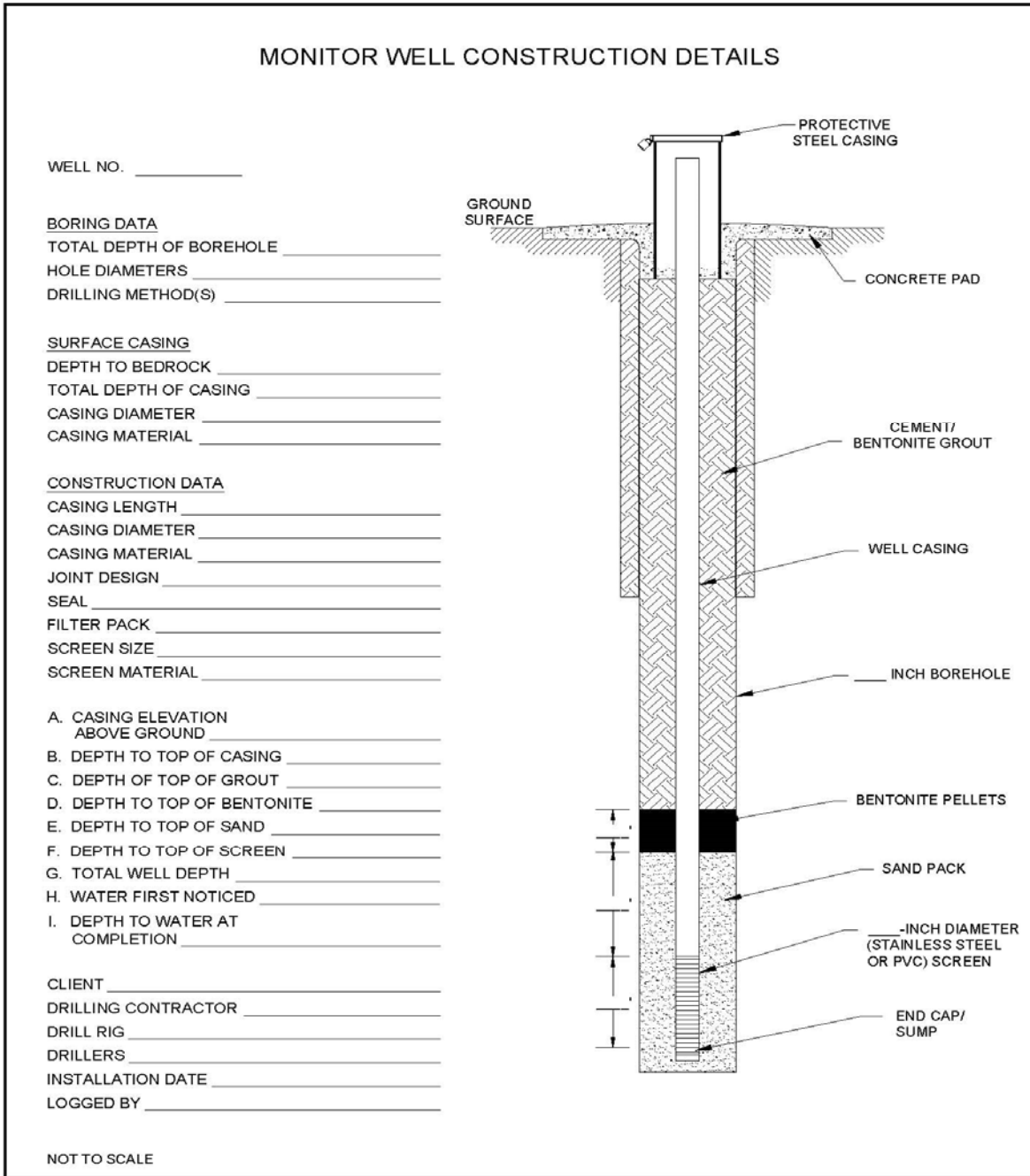

Details of Monitoring Well \_\_\_\_\_  
Project \_\_\_\_\_  
Project Location \_\_\_\_\_

**Figure 4**

**Design and Installation of  
Monitoring Wells in Aquifers**

SOP 4-4  
Revision: 8  
Date: February 2015

**Typical Construction Detail of Flush-Mount Double-Cased Monitor Well  
(Not to Scale - Shown as an Example Only)**

MONITOR WELL CONSTRUCTION DETAILS

WELL NO. \_\_\_\_\_

BORING DATA

TOTAL DEPTH OF BOREHOLE \_\_\_\_\_  
HOLE DIAMETERS \_\_\_\_\_  
DRILLING METHOD(S) \_\_\_\_\_

SURFACE CASING

DEPTH TO BEDROCK \_\_\_\_\_  
TOTAL DEPTH OF CASING \_\_\_\_\_  
CASING DIAMETER \_\_\_\_\_  
CASING MATERIAL \_\_\_\_\_

CONSTRUCTION DATA

CASING LENGTH \_\_\_\_\_  
CASING DIAMETER \_\_\_\_\_  
CASING MATERIAL \_\_\_\_\_  
JOINT DESIGN \_\_\_\_\_  
SEAL \_\_\_\_\_  
FILTER PACK \_\_\_\_\_  
SCREEN SIZE \_\_\_\_\_  
SCREEN MATERIAL \_\_\_\_\_

- A. CASING ELEVATION ABOVE GROUND \_\_\_\_\_
- B. DEPTH TO TOP OF CASING \_\_\_\_\_
- C. DEPTH OF TOP OF GROUT \_\_\_\_\_
- D. DEPTH TO TOP OF BENTONITE \_\_\_\_\_
- E. DEPTH TO TOP OF SAND \_\_\_\_\_
- F. DEPTH TO TOP OF SCREEN \_\_\_\_\_
- G. TOTAL WELL DEPTH \_\_\_\_\_
- H. WATER FIRST NOTICED \_\_\_\_\_
- I. DEPTH TO WATER AT COMPLETION \_\_\_\_\_

CLIENT \_\_\_\_\_  
DRILLING CONTRACTOR \_\_\_\_\_  
DRILL RIG \_\_\_\_\_  
DRILLERS \_\_\_\_\_  
INSTALLATION DATE \_\_\_\_\_  
LOGGED BY \_\_\_\_\_

NOT TO SCALE

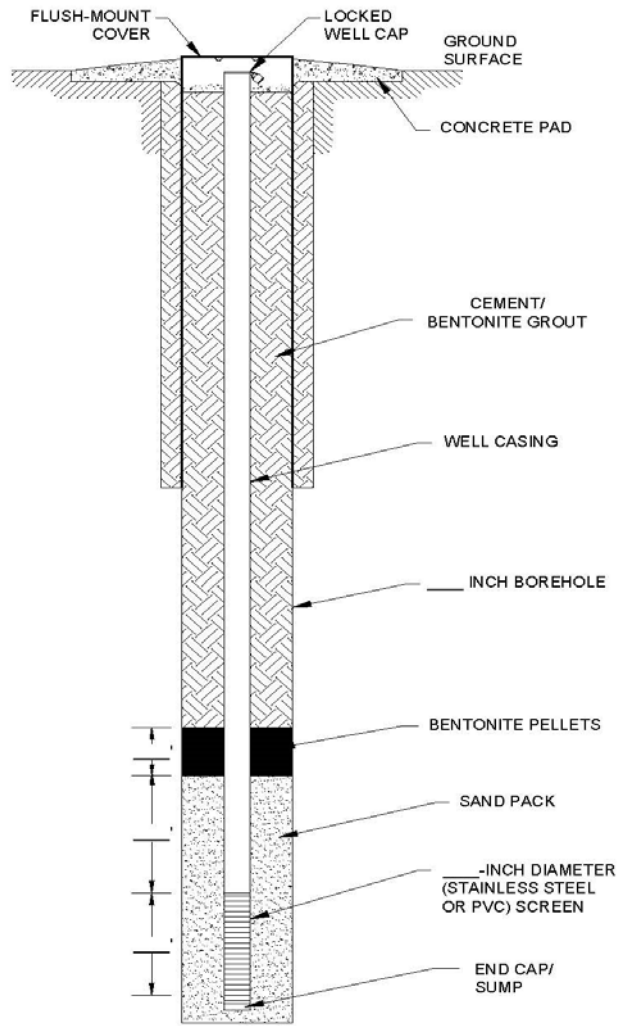

Details of Monitoring Well \_\_\_\_\_  
Project \_\_\_\_\_  
Project Location \_\_\_\_\_

## Field Equipment Decontamination at Nonradioactive Sites

SOP 4-5  
Revision: 10  
Date: February 2015

Approved:

  
Signature

Technical Review:

Robert R. Alexander

### 1.0 Objective

The objective of this technical standard operating procedure (SOP) is to describe the general procedures required for decontamination of field equipment at nonradioactive sites. This SOP serves as a general guide and is applicable at most sites; however, it shall be noted that site-specific conditions (i.e., type of contamination, type of media sampled), the governing agency (e.g., EPA, DOE, USACE), and site-specific work plans, sampling and analysis plans and/or quality assurance (QA) project plans may require modifications to the decontamination procedures provided in this SOP. Decontamination of field equipment is necessary to ensure acceptable quality of samples by preventing cross contamination. Further, decontamination reduces health hazards and prevents the spread of contaminants offsite.

### 2.0 Background

#### 2.1 Definitions

**Acid Rinse** - A solution of 10 percent nitric or hydrochloric acid made from reagent grade acid and analyte-free water.

**Analyte-Free Water** - Tap water that has been treated so that the water contains no detectable heavy metals or other inorganic compounds. Analyte-free water shall be stored only in clean glass, stainless steel, or plastic containers that can be closed when not in use.

**Clean** - Free of contamination and when decontamination has been completed in accordance with this SOP.

**Cross Contamination** - The transfer of contaminants through equipment or personnel from the contamination source to less contaminated or noncontaminated samples or areas.

**Decontamination** - The process of rinsing or otherwise cleaning the surfaces of sampling or other equipment to rid them of contaminants and to minimize the potential for cross contamination of samples or exposure to personnel.

**Safety Data Sheets (SDS)** - These documents discuss the proper storage and physical and toxicological characteristics of a particular substance used during decontamination. These documents, generally included in site health and safety plans, shall be kept on site at all times during field operations.

**Organic-Free/Analyte-Free Water** - Tap water that has been treated so that the water meets the analyte-free water criteria and contains no detectable organic compounds. Organic-free/analyte-free water shall be stored only in clean glass, Teflon™, or stainless steel containers that can be closed when not in use.

**Potable Water** - Tap water may be obtained from any municipal system. Chemical analysis of the water source may be required before it is used for decontamination purposes.

**Sampling Equipment** - Equipment that comes into direct contact with the sample media. Such equipment includes split spoon samplers, well casing and screens, and spatulas or bowls used to homogenize samples.

**Soap** - Low-sudsing, nonphosphate detergent such as Liquinox™.

**Solvent Rinse** - Pesticide grade, or better, isopropanol, acetone, or methanol.

## Field Equipment Decontamination at Nonradioactive Sites

SOP 4-5

Revision: 10

Date: February 2015

### 2.2 Associated Procedures

- SOP 1-1 – *Surface Water Sampling*
- SOP 1-3 – *Surface Soil Sampling*
- SOP 1-4 – *Subsurface Soil Sampling*
- SOP 1-5 – *Groundwater Sampling Using Bailers*
- SOP 1-7 – *Wipe Sampling*
- SOP 1-9 – *Tap Water Sampling*
- SOP 1-11 – *Sediment/Sludge Sampling*
- SOP 1-12 – *Low Flow (Low-Stress) Groundwater Sampling*
- SOP 1-13 – *Drum Sampling*
- SOP 1-14 – *Lagoon Sampling*
- SOP 1-15 – *Procedures for Determination of Screening-Level Elemental Concentrations in Soil and Sediment using Field Portable X-Ray Fluorescence Spectrometry*
- SOP 2-2 – *Guide to Handling Investigation-Derived Waste*
- SOP 3-1 – *Geoprobe® Sampling*

### 3.0 Responsibilities

The project manager or designee, generally the field team leader (FTL), ensures that field personnel are trained in the performance of this procedure and that decontamination is conducted in accordance with this SOP and site-specific work plans. The FTL may also be required to collect and document rinsate samples (also known as equipment blanks) to provide quantitative verification that these procedures have been correctly implemented.

**Note:** Responsibilities may vary from site to site. Therefore, all field team member responsibilities shall be defined in the field plan or site-/project-specific quality assurance project plan (QAPP).

### 4.0 Required Equipment

- Stiff-bristle scrub brushes
- Plastic buckets and troughs
- Soap
- Nalgene or Teflon sprayers or wash bottles or 2- to 5-gallon, manual-pump sprayer (pump sprayer material must be compatible with the solution used)
- Plastic sheeting, plastic bags, and/or aluminum foil to keep decontaminated equipment clean between uses
- Disposable wipes, rags, or paper towels
- Potable water\*
- Analyte-free water
- Organic-free/analyte-free water
- Gloves, safety glasses, and other protective clothing as specified in the site-specific health and safety plan
- High-pressure pump with soap dispenser or steam-spray unit (for large equipment only)
- Appropriate decontamination solutions pesticide grade or better and traceable to a source (e.g., 10 percent and/or 1 percent nitric acid [HNO<sub>3</sub>], acetone, methanol, isopropanol, hexane)
- Tools for equipment assembly and disassembly (as required)
- 55-gallon drums or tanks for temporary storage of decontamination water (as required)
- Pallets for drums or tanks holding decontamination water (as required)

\* Potable water may be required to be tested for contaminants before use. Check field plan for requirements.

## Field Equipment Decontamination at Nonradioactive Sites

SOP 4-5

Revision: 10

Date: February 2015

### 5.0 Procedures

All reusable equipment (nondedicated) used to collect, handle, or measure samples shall be decontaminated before coming into contact with any sampled media or personnel using the equipment. Decontamination of equipment shall occur either at a central decontamination station or at portable decontamination stations set up at the sampling location, drill site, or monitoring well location. The centrally located decontamination station shall include an appropriately sized bermed and lined area on which equipment decontamination shall occur and shall be equipped with a collection system and storage vessels. In certain circumstances, berming is not required when small quantities of water are being generated and for some short duration field activities (i.e., pre-remedial sampling). Equipment shall be transported to and from the decontamination station in a manner to prevent cross contamination of equipment and/or area. For example, precautions taken may include enclosing augers in plastic wrap while being transported on a flatbed truck.

The decontamination area shall be constructed so that contaminated water is either collected directly into appropriate containers (5-gallon buckets or steel wash tubs) or within the berms of the decontamination area that then drains into a collection system. Water from the collection system shall be transferred into 55-gallon drums or portable tanks for temporary storage. Typically, decontamination water shall be staged until sampling results or waste characterization results are obtained and evaluated and the proper disposition of the waste is determined (SOP 2-2, *Guide to Handling Investigation-Derived Waste*). The exact procedure for decontamination waste disposal shall be discussed in the work plan. Also, solvent and acid rinse fluids may need to be segregated from other investigation-derived wastes.

All items that shall come into contact with potentially contaminated media shall be decontaminated before use and between sampling and/or drilling locations. If decontaminated items are not immediately used, they shall be covered either with clean plastic or aluminum foil depending on the size of the item. All decontamination procedures for the equipment being used are as follows:

#### General Guidelines

- Potable, analyte-free, and organic-free/analyte-free water shall be free of all contaminants of concern. Following the field QA sampling procedure described in the sampling plan, analytical data from the water source may be required.
- Sampling equipment that has come into contact with oil and grease shall be cleaned with methanol or other approved alternative to remove the oily material. This may be followed by a hexane rinse and then another methanol rinse. Regulatory or client requirements regarding solvent use shall be stated in the sampling plan.
- All solvents and acids shall be pesticide grade or better and traceable to a source. If provided, certificates of analyses should be placed in the project files. The corresponding lot numbers shall be recorded in the appropriate logbook.

**Note:** Solvents and acids are potentially hazardous materials and must be handled, stored, and transported accordingly. Solvents shall never be used in a closed building. See the site-specific health and safety plan and/or the chemical's MSDS for specific information regarding the safe use of the chemical.

- Decontaminated equipment shall be allowed to air dry before being used.
- Documentation of all equipment type, date, time, and method of decontamination along with associated field QA sampling shall be recorded in the appropriate logbook.
- Gloves, boots, safety glasses, and any other personnel protective clothing and equipment shall be used as specified in the site-specific health and safety plan.

### 5.1 Heavy Equipment Decontamination

Heavy equipment includes drilling rigs, well development rigs, and backhoes. Follow these steps when decontaminating this equipment:

1. Establish a bermed decontamination area that is large enough to fully contain the equipment to be cleaned. If available, an existing wash pad or appropriate paved and bermed area may be used; otherwise, use one or more layers of heavy plastic sheeting to cover the ground surface and berms. All decontamination pads shall be upwind of the area under investigation.

## Field Equipment Decontamination at Nonradioactive Sites

SOP 4-5

Revision: 10

Date: February 2015

2. With the rig in place, spray areas (rear of rig or backhoe) exposed to contaminated media using a hot water high-pressure sprayer. Be sure to spray down all surfaces, including the undercarriage.
3. Use brushes, soap, and potable water to remove dirt whenever necessary.
4. Remove equipment from the decontamination pad and allow it to air dry before returning it to the work site.
5. After decontamination activities are completed, collect all contaminated wastewater, plastic sheeting, and disposable gloves, boots, and clothing in separate containers or receptacles. All receptacles containing contaminated items must be properly labeled for disposal as detailed in the field plan. Liquids and solids must be drummed separately.

### 5.2 Downhole Equipment Decontamination

Downhole equipment includes hollow-stem augers, drill pipes, rods, stems, etc. Follow these steps when decontaminating this equipment:

1. Set up a centralized decontamination area, if possible. This area shall be set up to collect contaminated rinse waters and to minimize the spread of airborne spray.
2. Set up a "clean" area upwind of the decontamination area to receive cleaned equipment for air-drying. At a minimum, clean plastic sheeting must be used to cover the ground, tables, or other surfaces on which decontaminated equipment is to be placed. All decontamination pads shall be upwind of any areas under investigation.
3. Place the object to be cleaned on aluminum foil or plastic-covered wooden sawhorses or other supports. The objects to be cleaned shall be at least 2 feet above the ground to avoid splashback when decontaminating.
4. Using soap and potable water in the hot water high-pressure sprayer (or steam unit), spray the contaminated equipment. Aim downward to avoid spraying outside the decontamination area. Be sure to spray inside corners and gaps especially well. Use a brush, if necessary, to dislodge dirt.
5. If using soapy water, rinse the equipment using clean, potable water. If using hot water, the rinse step is not necessary if the hot water does not contain a detergent. If the hot water contains a detergent, this final clean water rinse is required.
6. Using a suitable sprayer, rinse the equipment thoroughly with analyte-free water.
7. Remove the equipment from the decontamination area and place in a clean area upwind to air dry.
8. After decontamination activities are completed, collect all contaminated wastewaters, plastic sheeting, and disposable gloves, boots, and clothing in separate containers or receptacles. All receptacles containing contaminated items must be properly labeled for disposal. Liquids and solids must be drummed separately.

### 5.3 Sampling Equipment Decontamination

Follow these steps when decontaminating sampling equipment:

1. Set up a decontamination line on plastic sheeting. The decontamination line shall progress from "dirty" to "clean." A clean area shall be established upwind of the decontamination wash/rinse activities to dry the equipment. At a minimum, clean plastic sheeting must be used to cover the ground, table, or other surfaces that the decontaminated equipment is placed for drying.
2. Disassemble any items that may trap contaminants internally. Do not reassemble the items until decontamination and air drying are complete.

## Field Equipment Decontamination at Nonradioactive Sites

SOP 4-5

Revision: 10

Date: February 2015

3. Wash the items with potable water and soap using a stiff brush as necessary to remove particulate matter and surface films. The items may be steam cleaned using soap and hot water as an alternative to brushing. Note: Polyvinyl chloride or plastic items shall not be steam cleaned. Items that have come into contact with concentrated and/or oily contaminants may need to be rinsed with a solvent such as hexane and allowed to air dry prior to this washing step.
4. Thoroughly rinse the items with potable water.
5. The specific chemicals and/or fluids to be used in the decontamination process will be defined in the sampling plan. If sampling for metals, typically the potable water and soap wash is followed by a potable water rinse then an analyte-free water rinse; alternatively, an acid solution (e.g., 10 percent nitric acid) rinse followed by a rinse using analyte-free water may be specified in some instances. If sampling for organic compounds, thoroughly rinse the items with solvent (e.g., isopropanol) followed by a rinse using organic-free/analyte-free water. Again, the specific chemicals used in any acid rinse or solvent rinse phases shall be specified in the sampling plan. Any acid rinsate and solvent rinsate must each be containerized separately. Acids and solvents are potentially hazardous materials and care must be exercised when using these chemicals to prevent adverse health affects (e.g., skin burns, irritation to the eyes and respiratory system). Appropriate personal protective equipment must be worn when using these chemicals. The use of acids and solvents for decontamination should be carefully considered. These chemicals (including spent rinsate) must be managed and stored appropriately. Special measures such as proper labels, paperwork, notification, etc. may be required when transporting or shipping these chemicals.
6. Allow the items to air dry completely.
7. After drying, reassemble the parts as necessary and wrap the items in clean plastic wrap or in aluminum foil.
8. After decontamination activities are completed, collect all contaminated waters, used solvents and acids, plastic sheeting, and disposable personal protective equipment. Place the contaminated items in properly labeled drums for disposal. Liquids and solids must be drummed separately. Refer to site-specific plans for labeling and waste management requirements.

### 5.4 Pump Decontamination

Follow the manufacturer's recommendation for specified pump decontamination procedures. At a minimum, follow these steps when decontaminating pumps:

1. Set up the decontamination area and separate "clean" storage area using plastic sheeting to cover the ground, tables, and other surfaces. Set up four containers: the first container shall contain dilute (nonfoaming) soapy water, the second container shall contain potable water, the third container shall be empty to receive wastewater, and the fourth container shall contain analyte-free water.
2. The pump shall be set up in the same configuration as for sampling. Submerge the pump intake (or the pump, if submersible) and all downhole-wetted parts (tubing, piping, foot valve) in the soapy water of the first container. Place the discharge outlet in the wastewater container above the level of the wastewater. Pump soapy water through the pump assembly until it discharges to the waste container. Scrub the outside of the pump and other wetted parts with a metal brush.
3. Move the pump assembly to the potable water container while leaving discharge outlet in the waste container. All downhole-wetted parts must be immersed in the potable water rinse. Pump potable water through the pump assembly until it runs clear.
4. Move the pump intake to the analyte-free water container. Pump the water through the pump assembly. Pump the volume of water through the pump specified in the field plan. Usually, three pump-and-line-assembly volumes shall be required.
5. Decontaminate the discharge outlet by hand, following the steps outlined in Section 5.3.



## Field Equipment Decontamination at Nonradioactive Sites

SOP 4-5

Revision: 10

Date: February 2015

- Remove the decontaminated pump assembly to the clean area and allow it to air dry upwind of the decontamination area. Intake and outlet orifices shall be covered with aluminum foil to prevent the entry of airborne contaminants and particles.

### 5.5 Low Stress (Low Flow) Sampling Pump Decontamination

Sampling equipment used for Low Stress (Low Flow) Groundwater Sampling (SOP 1-12) must be decontaminated thoroughly each day before use (daily decontamination) and after each well is sampled (between-well decontamination). All non-disposable equipment, including the pump (support cable and electrical wires which are in contact with the sample) will be decontaminated as described below. Dedicated, in-place pumps and tubing must be thoroughly decontaminated using "daily decontamination" procedures prior to their initial use or installation.

#### 5.5.1 Prior to Sampling Event Decontamination

Please Note: Steps 5 through 13 should only be performed once (for each pump that is to be used) before the commencement of a particular sampling event by a person qualified to disassemble pumps.

- Pre-rinse: Operate pump in a deep basin containing 8 to 10 gallons of potable water for 5 minutes and thoroughly flush other equipment with potable water.
- Wash: Operate pump in a deep basin containing 8 to 10 gallons of a non-phosphate detergent solution, such as Liquinox™, for 5 minutes and thoroughly flush other equipment with fresh detergent solution. Use the detergent sparingly.
- Rinse: Operate pump in a deep basin of potable water for 5 minutes and thoroughly flush other equipment with potable water for 5 minutes.
- Analyte-Free Rinse: Operate pump in a deep basin of analyte-free water to pump out 1 to 2 gallons of this final rinse water.
- Disassemble pump.
- Wash pump parts (inlet screen, shaft suction interconnector, motor lead assembly, stator house): Place the disassembled parts of the pump into a deep basin containing 8 to 10 gallons of non-phosphate detergent solution. Scrub all pump parts with a test tube brush.
- Rinse pump parts with potable water for five minutes.
- Rinse the pump parts with demonstrated analyte-free water.
- If sampling for metals, an acid rinse may be specified in the sampling plan; if so, place impeller assembly in a large glass beaker and rinse with 1% nitric acid (HNO<sub>3</sub>).
- Rinse impeller assembly with potable water for five minutes.
- If sampling for organics, a solvent rinse may be specified; if so, place impeller assembly in a large glass bleaker and rinse with isopropanol or appropriate organic solvent specified in the site-specific plan.
- Thoroughly rinse impeller assembly with demonstrated analyte-free water.
- Reassemble pump.

#### 5.5.2 Daily and Between-Well Decon

- Pre-rinse: Operate pump in a deep basin containing 8 to 10 gallons of potable water for 5 minutes and thoroughly flush other equipment with potable water for five minutes.

## Field Equipment Decontamination at Nonradioactive Sites

SOP 4-5

Revision: 10

Date: February 2015

2. Wash: Operate pump in a deep basin containing 8 to 10 gallons of a non-phosphate detergent solution, such as Liquinox™, for 5 minutes and thoroughly flush other equipment with fresh detergent solution. Use the detergent sparingly.
3. Rinse: Operate pump in a deep basin of potable water for 5 minutes and thoroughly flush other equipment with potable water for five minutes.
4. Final Rinse: Operate pump in a deep basin of analyte-free water to pump out 1 to 2 gallons of this final rinse water.

### 5.6 Instrument Probe Decontamination

Instrument probes used for field measurements such as pH meters, conductivity meters, etc. shall be decontaminated between samples and after use with analyte-free, or better, water.

### 5.7 Waste Disposal

Refer to site-specific plans and SOP 2-2 for waste disposal requirements. The following are guidelines for disposing of wastes:

- All wash water, rinse water, and decontamination solutions that have come in contact with contaminated equipment are to be handled, packaged, labeled, marked, stored, and disposed of as investigation-derived waste.
- Small quantities of decontamination solutions may be allowed to evaporate to dryness.
- If large quantities of used decontamination solutions shall be generated, each type of waste shall be contained in separate containers.
- Unless otherwise required, plastic sheeting and disposable protective clothing may be treated as solid, nonhazardous waste.
- Waste liquids shall be sampled, analyzed for contaminants of concern in accordance with disposal regulations, and disposed of accordingly.

### 6.0 Restrictions/Limitations

Nitric acid and polar solvent rinses are necessary only when sampling for metals or organics, respectively. These steps shall not be used, unless required, because of the potential for acid burns and ignitability hazards.

If the field equipment is not thoroughly rinsed and allowed to completely air dry before use, volatile organic residue, which interferes with the analysis, may be detected in the samples. The occurrence of residual organic solvents is often dependent on the time of year sampling is conducted. In the summer, volatilization is rapid, and in the winter, volatilization is slow. Check with your EPA region, state, and client for approved decontamination solvents.

### 7.0 References

American Society for Testing and Materials. 2015. *Standard Practice for Decontamination of Field Equipment at Waste Sites*, ASTM D5088-15. January 15.

Puls, R.W. and M.J. Barcelona. 1996. *Low-Flow (Minimal Drawdown) Ground-water Sampling Procedures*, EPA/540/S-95/504.

U. S. Environmental Protection Agency. 1987. *A Compendium of Superfund Field Operations Methods*, EPA/540/P-87/001.1.

\_\_\_\_\_. 1998. EPA Region 2, *Ground Water Sampling Procedure Low Stress (Low Flow) Purging and Sampling*, March 16.

\_\_\_\_\_. 1992. *Standard Operating Safety Guidelines*; Publication 9285.1-03. June.

\_\_\_\_\_. 2011. Region 4. *The Field Branches Quality System and Technical Procedures, Soil Sampling*. SESDPROC-205-R2. December. <http://www.epa.gov/region4/sesd/fbqstp/>

## Hydraulic Conductivity Testing

SOP 4-6

Revision: 5

Date: February 2015

Approved:

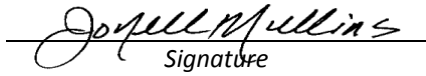
  
Signature

Technical Review:

John Dougherty

### 1.0 Objective

The objective of this technical standard operating procedure (SOP) is to define requirements for conducting and analyzing in situ hydraulic conductivity (slug) tests in small, developed wells.

### 2.0 Background

#### 2.1 Definitions

**Slug Testing** - A rapid and easy means of estimating the hydraulic conductivity of an aquifer. If the thickness of the aquifer is known, then the transmissivity can also be determined. Slug testing is accomplished by adding (or removing/ displacing) a known volume to (or from) the monitoring well to create a rapid rise (or fall) in water level. Water levels are then measured as the water level in the well returns to static (pre-test) conditions. American Society for Testing and Materials method D4044 provides an overview of slug testing (ASTM 1996). Butler (1998) is a good reference for the design and analysis of slug tests over a full range of aquifer conditions.

**Slug Bar** - A weighted cylinder that is used in displacing water in a well of known volume. A bailer may be used in place of a slug bar under low-recharge aquifer conditions.

**Pneumatic System** - A system that uses an air pump, compressor, or compressed air cylinder to increase the air pressure in the well, which is sealed with an air-tight cap that has ports through which the compressed air is introduced and a water level indicator or pressure transducer can be inserted. This displacement method is commonly employed in high transmissivity aquifers where aquifer response is rapid and it is difficult to achieve the rapid initial displacement required using a slug bar or bailer. In all cases, the rate of water level recovery is then measured using a pressure transducer and data recorder or a water level meter and stopwatch (the former method is preferable in most environments). Data, as displacement-time pairs, are then graphed and used in equations to determine hydraulic conductivity.

#### 2.2 Associated Procedures

- SOP 1-5, *Groundwater Sampling with Bailers*
- SOP 1-6, *Water Level Measurement*
- SOP 2-6, *Handling Investigative-Derived Waste*
- SOP 4-1, *Field Logbook Content and Control*
- SOP 4-3, *Well Development and Purging*
- SOP 4-4, *Design and Installation of Monitoring Wells in Aquifers*
- SOP 4-5, *Field Equipment Decontamination at Nonradioactive Sites*

#### 2.3 Discussion

Advantages of slug testing over pump testing include the fact that little or no contaminated water is produced requiring containment and disposal as well as that several areas can be tested in a relatively short period of time. A disadvantage of slug testing is that the resulting estimate of hydraulic conductivity is limited to a small volume of the aquifer around the tested well and care must be taken in extrapolating the results from one well to other areas or intervals of the aquifer.

If possible, when designing the field program or considering in which interval to place a well screen, try to screen only one formation type. If a well is screened across more than one formation (such as fine sand and coarse sand or overburden and bedrock) the results must be analyzed and interpreted in the hydrogeologic context.

## Hydraulic Conductivity Testing

SOP 4-6

Revision: 5

Date: February 2015

### 3.0 Responsibilities

**Site Manager** - The site manager is responsible for ensuring that field personnel have been trained in conducting slug tests and for ensuring that slug tests are conducted in accordance with this procedure.

**Field Team Leader** - The field team leader is responsible for performing slug tests in accordance with this procedure and for verifying that the data collected are adequate and of high quality. The project field geologist shall perform a field calculation to check data quality.

**Note:** Responsibilities may vary from site to site. Therefore, all field team member responsibilities shall be defined in the field plan or site-/project-specific quality assurance plan.

### 4.0 Required Equipment

The following equipment shall be used when performing a rising or falling-head slug test in a monitoring well. Site-specific conditions may warrant the use of additional equipment.

- Pressure transducer and data recorder, if data are to be automatically recorded (recommended) and manufacturers' instructions
- Laptop or hand-held computer for downloading and viewing data (field printer optional)
- Water level measuring device
- Stopwatch, if measurements collected manually (not recommended)
- Slug device of known volume
- Rope or wire
- Duct tape
- Field logbook
- Decontamination equipment and supplies
- Data on the construction of the well: depth to screen, screen length, well drilled diameter, riser diameter, height of sandpack above screen and length of riser above ground surface

Note that the well construction data shall be used so that the slug test data being collected are appropriate and of acceptable quality. Additional information (e.g., distance from screen to confining layer) may be necessary to analyze the data and determine the hydraulic conductivity. Data analysis is not covered under this procedure.

The slug bar shall be constructed of plastic, such as polyvinyl chloride (PVC), or metal such as aluminum or steel (depending upon the chemical environment in the well) and have no buoyancy. For example, a standard slug is constructed with a PVC pipe filled with sand and capped at both ends. The slug bar shall be of sufficient size to cause a recommended minimum of 1 to 3 feet of displacement in a well. A slightly lesser or greater head change is acceptable so long as a sufficient response curve is recorded that can be applied in a subsequent analysis. For a 2-inch diameter monitoring well, the slug bar shall be no more than 1.5 inches in diameter and a minimum of 5 feet long. For a 4-inch diameter well, the slug bar shall be no more than 3 inches in diameter and a minimum of 5 feet long. The slug bar shall be securely fastened to a nylon rope or braided metal wire.

A standard sampling or well development bailer may be used in place of the slug bar, as long as the volume of water displaced by the bailer is sufficient to change the water level in the well a minimum of 1 to 3 feet. If the bailer is to be used for a falling-head test, it shall be filled with analyte-free water so that the bailer will not have any buoyancy.

### 5.0 Procedures

#### 5.1 Preparation

The following steps must be followed when preparing for slug testing:

1. Lay plastic sheeting around the wellhead. Arrange needed equipment and decontamination materials on the sheet or on a table.
2. Put on personnel protective clothing, as specified in the site-specific health and safety plan.

## Hydraulic Conductivity Testing

SOP 4-6

Revision: 5

Date: February 2015

3. Open the protective casing locking lid and vented riser caps following the procedures outlined in SOP 1-6. Note the physical condition of the well, including damage, deterioration and signs of tampering. Note any unusual odors, sounds, or difficulties in opening the well. Record organic vapor readings with a suitable organic vapor screening device.
4. Measure and record the static water level, the depth to the bottom of the well and inside diameter of the well casing. Record these data in the appropriate logbook.
5. If using a pressure transducer and data logger (transducers with built-in data loggers are commonly used for slug tests), lower the pressure transducer into the well to a sufficient depth so that the transducer will be below the maximum depth reached by the bottom of the slug bar or other displacement device. If necessary, calibrate the transducer as specified by the manufacturer. Allow the transducer to temperature equilibrate in the well for approximately 15 minutes (or as recommended by the manufacturer) after insertion and before any calibration or test procedure to ensure that it will accurately record water level changes. Make sure that the transducer is not placed below its maximum operating depth, or it will not be able to detect any change in pressure. For example, pressure increases 1 pound per square inch (psi) per 2.3 feet of head; therefore, a 10 psi transducer will function to a depth of 23 feet below the water level in the well.
6. Secure the pressure transducer cable using a Kellems grip or similar device. The transducer cable shall lay flat along side the well riser, so that disturbance by the slug bar will be avoided.
 

**Note:** Do not kink the transducer cable, otherwise the pressure equalization vent tube in the cable will be damaged and the transducer will not function properly.
7. Allow the water level in the well to recover to static after emplacement of the pressure transducer, before starting the test. Measure and record this water level.
8. Program the data logger to record logarithmically, with a maximum time interval of no more than 1 minute between readings. If the formation is expected to have low hydraulic conductivity, the maximum interval between readings can be set to a longer time interval, such as 10 minutes.
9. Confirm and/or set the transducer and logger parameters as recommended by the manufacturer. This task may also be performed before placing the instrument in the well.
10. Determine the distance from the top of the well riser to the water surface in the well and add 1 foot to this length. The resulting length is the amount of wire or rope needed so that the slug bar or bailer will be submerged a minimum of 1 foot when it is placed in the well. A loop shall be placed in the rope or wire at this length and a strong metal rod or wooden stick placed and secured through the loop. When inserted into the well, the slug bar shall be a distance (more than 1 foot) above the transducer to avoid disturbing the measuring device.
11. If depth readings are to be recorded manually (this procedure is not recommended but may be used in formations suspected of having low hydraulic conductivity, less than 1 foot per day), readings shall be taken every 10 seconds for the first minute of the test, every 30 seconds for the next 4 minutes and every minute until 10 minutes. Thereafter, readings shall be taken every 5 minutes for the duration of the test. If the well has not recovered within 1 hour, readings shall be taken every 0.5 hours until 6 hours and 1 hour every hour thereafter. This process will require two personnel during the first 10 minutes of the test: one to act as time keeper/data recorder and one to measure depth to water in the well.

## 5.2 Standard Displacement Slug Tests

### 5.2.1 Falling-Head Slug Test Procedure

This test can only be conducted in wells whose screens are fully submerged, otherwise, displaced water will be introduced into the unsaturated zone and recovery rates will be due to flow in both the unsaturated and saturated zones. All slug test analytical procedures assume flow in the saturated zone only. The following steps must be followed when performing falling-head slug tests:

## Hydraulic Conductivity Testing

SOP 4-6

Revision: 5

Date: February 2015

1. Place the slug or bailer in the well until the bottom of the displacement device is no more than 6 inches to 1 foot above the water level in the well. The person holding the device shall be holding the rope or wire by the rod or stick described in Section 5.1, ninth bullet.
2. Switch on the data recorder, or set the water level meter probe near the level at which water is expected to rise.
3. To start the test, the person holding the slug bar will signal the person operating the data logger or water level indicator, then rapidly lower the displacement device into the well until the stick or rod is resting horizontally on top of the well riser. The slug bar shall not be dropped, to minimize sloshing in the well. The data logger is turned on immediately prior to the slug bottom entering the water.
4. Continue recording depth-time data until the well has recovered to at least 90 percent of the static water level. When using data recorders, it is advisable to check and record the reading every few minutes to ensure that data are being properly recorded. If 90 percent recovery has not occurred within 12 hours, the test may be stopped. Field conditions and time constraints may warrant stopping the test in less than 12 hours. The final decisions under these circumstances will be the responsibility of the field team leader.
5. Record the time of test completion and file name in the logbook.
6. Review the response curve. If a sufficient response curve was not recorded (e.g., logging was not started soon enough to identify maximum water level displacement), then the test shall be repeated. If an acceptable response curve is not being recorded due to field conditions (e.g., no water level response due to high hydraulic conductivity) the project manager shall be notified and a determination on the well test shall be made.
7. Decontaminate all equipment according to SOP 4-5. Clean up the site, and close and lock the well before leaving. Contaminated plastic sheeting and disposable protective clothing shall be taken to designated disposal containers.
8. Download the data logger to a computer or to hardcopy to ensure that the data is not inadvertently lost. If the data were recorded manually, calculate the relative change in head by subtracting the recorded depths to water during recovery from the initial static depth to water reading and record the absolute value of that change, for each depth-time data pair.

**Note:** Both rising- and falling-head slug tests may be carried out in the same operation by first measuring the rate of water level fall immediately after slug insertion, then measuring the rate of water level rise after slug withdrawal. Be sure that the well has recovered to the static water level before conducting the rising-head test. If using a data logger, the recovery tests needs to be set up and run as a separate test.

### 5.2.2 Rising-Head Slug Test Procedure

The steps for a rising-head test are essentially the same as those for a falling-head test. In a well screened across the water table, a rising-head test is the only test that is valid. The following steps must be followed when performing rising- head slug tests:

1. Lower the slug bar or bailer of known volume into the well until it is fully submerged. Allow the well to re-equilibrate to static water level. In formations of suspected low hydraulic conductivity, re-equilibration may take several hours or overnight. In such cases, it is suggested that the displacement device be placed in the well at the end of a field day and the test conducted the following day.
2. Turn on the data recorder, if used, or verify that static water level has been re-established with a water level meter.

**Hydraulic Conductivity Testing**

SOP 4-6

Revision: 5

Date: February 2015

3. To start the test, the person holding the slug bar will signal the person operating the data logger or water level indicator, then rapidly and smoothly raise the displacement device from the well until the bottom of the slug bar is above the water level in the well. The data logger is turned on or manual measurements commence at the moment the slug bar is raised and before it (or any portion of it) is removed from the water. If a data logger is being used, the slug bar wire or rope shall be secured to the well casing or riser for the duration of the test and only removed from the well after the test has been completed, to avoid disturbing or dislocating the pressure transducer.
4. Continue recording depth-time data until the well has recovered to at least 90 percent of the static water level. When using data recorders, it is advisable to check and record the reading every few minutes to ensure that data are being properly recorded. If 90 percent recovery has not occurred within 12 hours, the test may be stopped. Field conditions and time constraints may warrant stopping the test in less than 12 hours. The final decisions under these circumstances will be the responsibility of the field team leader.
5. Record the time of test completion and file name in the logbook.
6. Review the response curve. If a sufficient response curve was not recorded (e.g., logging was not started soon enough to identify maximum water level displacement), then the test shall be repeated. If an acceptable response curve is not being recorded due to field conditions (e.g., no water level response due to high hydraulic conductivity), the project manager shall be notified and a determination on the well test shall be made.
7. Decontaminate all equipment according to SOP 4-5. Clean up the site, and close and lock the well before leaving. Contaminated plastic sheeting and disposable protective clothing shall be taken to designated disposal containers.
8. Download the data logger to a computer or to hardcopy to ensure that the data is not inadvertently lost. If the data were recorded manually, calculate the relative change in head by subtracting the recorded depths to water during recovery from the initial static depth to water reading and record the absolute value of that change, for each depth-time data pair.

**5.3 Pneumatic Rising-Head Tests**

This test can be performed in aquifers of high hydraulic conductivity that are expected to respond very rapidly to slug displacement. It can only be performed in wells where the screen is substantially below the water table, otherwise, increased air pressure in the well casing will be able to bleed off to the unsaturated zone through the well screen and the test will not be successful.

**5.3.1 Required Equipment**

In addition to the required equipment outlined in Section 4.0, the following equipment shall be used when conducting a pneumatic rising-head slug test.

- Minimum 30-psi rated transducer and data logger
- Electric water level indicator with on/off switch
- Pressure-tight "tree" assembly, as described below
- Short length (6 inches) of flexible rubber hose whose inside diameter is the same as the outside diameter of the well riser
- Two 2- or 4-inch diameter hose clamps
- Compressor, air pump, or compressed air tank with hose and appropriate adapters

The pressure-tight tree assembly is a device placed on the top of the well that will accomplish the following:

- Form a pressure-tight seal between the well and the atmosphere
- Allow the injection of compressed air into the well via an air hose connected to the pump, compressor, or air supply
- Provide a pressure-tight passage for a pressure transducer cable and a water level meter
- Allow for rapid well depressurization

## Hydraulic Conductivity Testing

SOP 4-6

Revision: 5

Date: February 2015

The tree is illustrated in Figure 1. If the top of the riser is threaded, the device may be screwed onto the riser if the threads are compatible (Teflon™ tape shall be used to ensure a good seal). If the threaded end of the riser has been cut off, a slip coupling will need to be placed over the base of the tree and the top of the riser. A small length of flexible rubber hose the same inside diameter as the outside diameter of the coupling will need to be slipped over the coupling and secured in place with tightly closed hose clamps to form a pressure-tight seal between the riser and the well.

The simplest method for providing access through the tree for the pressure transducer cable indicator is to use a modified standard large diameter black rubber cork. A hole that is the same diameter as the cable shall be drilled through the cork's axis and a vertical slit shall be cut radially from the hole to an edge of the cork. The pressure transducer cable shall be threaded through the hole and the water level indicator tape shall be placed flat in the slit. The cork shall be firmly placed in the top of the tree to form a pressure-tight seal. To ensure that the cork does not pop out while the well is under pressure, it can be secured in place with duct tape or a friction fit plastic cap placed over the cork and onto the tree.

The tree will have a standard ball valve with an inside valve orifice diameter no less than the diameter of the well riser as shown in Figure 1. In addition, a pressure-tight coupling (swage-loc, quick-connect, or Schrader valve) will be attached to the side of the tree to act as a compressed air inlet.

### 5.3.2 Preparation

Preparation procedures for the pneumatic test are similar to those for the standard slug bar displacement test, with the exception that an electronic data logger is a necessity for this procedure.

### 5.3.3 Pneumatic Slug Test Procedure

1. Install the test tree to the top of the well, using a method appropriate to the type of riser present (threaded or unthreaded). Make sure that the seal to the riser top is pressure-tight.
  2. Lower the pressure transducer into the well through the top of the tree to a minimum of 10 feet below the water table. The pressure transducer shall be rated no less than 30 psi. Allow the transducer to equilibrate at least 15 minutes before initiating any calibration or test procedure.
  3. Turn on and insert a water level indicator into the well to approximately 5 feet depth below the water table. Turn off the indicator.
  4. Secure the water level indicator and pressure transducer to the test tree using the rubber cork described in Section 5.3.1. Insert the transducer cable into the hole in the rubber cork via the slit and place the water level indicator tape flat in the slit. Place the cork firmly in the top of the tree so that no gaps are left in the cork. Place small strips of duct tape over the assembly to ensure that the seal is airtight and that the cork cannot loosen when the well is pressurized.
- Note:** During this procedure, do not kink the transducer cable or the pressure equalization vent tube in the cable will be damaged and the transducer will not function.
5. Connect the pressure transducer to the data logger and calibrate the system according to manufacturer's instructions. Set the data logger to record logarithmically with a maximum recording interval of no more than 1 minute. Set the logger to record relative change in head only.
  6. Connect the air hose to the compressed air supply, pump, or compressor and to the tree. Make sure the ball valve is securely closed.
  7. Turn on the water level indicator and start feeding compressed air to the well. When the water level in the well has been depressed sufficiently, the water level indicator submergence tone will stop sounding. The pressure required shall be no more than 2 or 3 pounds over atmospheric pressure.



## Hydraulic Conductivity Testing

SOP 4-6

Revision: 5

Date: February 2015

8. Simultaneously open the ball valve and activate the data logger. Open the ball valve quickly so that the pressure is released at once.
9. In highly permeable aquifers, the water level shall recover to pre-test water levels within a few seconds. Full recovery shall be accomplished in no more than 1 minute. In any event, do not stop the test until a minimum of 90 percent recovery can be confirmed with the data logger.
10. Review the response curve. If a sufficient response curve was not recorded (e.g., logging was not started soon enough to identify maximum water level displacement), then the test shall be repeated. If an acceptable response curve is not being recorded due to field conditions (e.g., no water level response due to high hydraulic conductivity) the project manager shall be notified and a determination on the well test shall be made.
11. Record the time of test completion and file name in the logbook.
12. Decontaminate all equipment according to SOP 4-5. Clean up the site, and close and lock the well before leaving. Contaminated plastic sheeting and disposable protective clothing shall be taken to designated disposal containers.
13. Download the data logger to a computer or to hardcopy to ensure that the data is not inadvertently lost.

## 6.0 Data Reduction and Analysis Procedures

### 6.1 General

The following slug test data reduction procedure and report is recommended.

- All raw data shall be printed out and listed as an appendix to the analysis report.
- All data shall be plotted using the graphing method of the accepted analytical solution. These plots shall be included as an appendix to the analysis report.
- All well geometry data shall be tabulated and included in the analysis report. Most of these data must be known before the start of testing, except for items related to the water level in the well at the time of testing. The purpose of this tabulation is to ensure consistent calculation of all variables required in the data analysis, make input into a data analysis computer program an easier task, and to make technical review of the analyses and input values easier. This table shall include the following items for each tested well or piezometer (the list of items may vary depending on the analytical method employed):
 

|   |   |
|---|---|
| - Well ground surface elevation   | - Elevation of base of aquifer (if available)                                   |
| - Well reference elevation (i.e., top of riser)                                   | - Aquifer saturated thickness   |
| - Depth to static water level at start of test                                    | - Depth to top of screen or open interval relative to the top of the aquifer    |
| - Elevation of static water level at start of test                                | - Depth to bottom of screen or open interval relative to the top of the aquifer |
| - Depth to top of screen or open interval from ground surface or top of casing    | - Length of saturated well screen   |
| - Depth to bottom of screen or open interval from ground surface or top of casing | - Length of saturated riser   |
| - Elevation of top of screen or open interval                                     | - Diameter of well riser and screen (or open interval)                          |
| - Elevation of bottom of screen or open interval                                  | - Diameter of borehole  |
| - Depth to base of aquifer (if available)   | - Grain-size of filter pack   |
- The report shall include a detailed description of the data collection procedures and test methods.
- The report shall include a detailed listing of all analysis results.

## Hydraulic Conductivity Testing

SOP 4-6

Revision: 5

Date: February 2015

- When reviewing the data for analysis, note that if the water level recovered to the static level (or close to it) before the test was stopped, only the data before 100 percent recovery shall be included in the data plot. Plotting 100 minutes of data when the recovery occurred rapidly (e.g., 30 seconds or 2 minutes) will make analysis of the actual response very difficult and often lead to a substantial underestimate of the formation hydraulic conductivity. Raw data plots shall also be examined for evidence of sloshing of the water level in the well caused by insertion or removal of the slug bar. In most cases, these early data points can also be removed from the data set and time values reset to the new starting point represented by the remaining data. This evaluation is shown on Figure 2. The data may also be removed using common software packages developed for analyzing slug tests.

### 6.2 Review and Analysis of Data

Slug test response generally falls into three categories illustrated on Figure 3. Overdamped or normal response occurs where the well recovers to static level without exceeding that level. Critically damped response occurs where the well recovers to static level and the water level flows above (rising-head test) or below (falling-head test) then recovers to static in a sinusoidal manner within one cycle, as shown in Figure 3. The third category is underdamped harmonic oscillatory response, where the water level in the well oscillates around the static water level as a sine wave of decreasing amplitude.

Slug test data are recommended to be analyzed with computer software; however, data may also be analyzed manually. The groundwater modeling tool kit contains Aquifer<sup>WIN32</sup> (ESI International), which is a program that may be used for analyzing slug test data. Other programs are also available. Software packages are useful since they can be used to manage a significant amount of data in short time periods and contain many different confined and unconfined slug test solutions. The trained user can use these benefits to generate detailed response curve graphs, precise hydraulic conductivity values, and insights into the hydrogeologic framework near the well. Regardless of the analytical method employed or whether the data is analyzed manually or by computer, the analyst shall review the original technical paper or textbook summary of the method to understand the mechanics and assumptions underlying the method before attempting any analysis.

Slug test data analyses and hydraulic conductivity calculations shall be performed by an experienced professional. Data analysis and parameter calculations are beyond the scope of this SOP and, therefore, are not discussed here.

### 7.0 Restrictions and Limitations

In wells in which the static water level and water levels induced during testing are above the top of the screened or open hole interval, both rising-head and falling-head tests shall be conducted to provide a redundancy check of results. However, in most cases, rising-head tests provide more consistent data, less subject to sloshing of the water level due to displacement by the slug bar than is often observed in falling-head tests. Falling-head slug tests are invalid in wells where the static water level is at or below the top of the screened or open-hole interval.

Regardless of which testing method is used, it is recommended that the hydraulic conductivity testing be performed three times in each well, if time constraints such as recovery time or the project schedule will allow multiple tests. The purpose of multiple testing is to demonstrate the precision of the test results. Ideally, the test results will be similar, which results in an increased level of confidence in the data. In addition, if one of the data sets is bad, there is additional data available for analysis.

### 8.0 References

American Society for Testing and Materials. 1996. *Standard Test Method (Field Procedure) for Instantaneous Change in Head (Slug) Tests for Determining Hydraulic Properties of Aquifers*. D4044 – 96 (Reapproved 2008).

Butler, James. 1998. *The Design, Performance, and Analysis of Slug Tests*. Lewis Publishers. 252 pp.

ESI International, see their website, <http://esinternational.com>, for current information on Aquifer<sup>WIN32</sup>

# Hydraulic Conductivity Testing

SOP 4-6  
Revision: 5  
Date: February 2015

Figure 1

Pneumatic Slug Test "Tree" Schematic

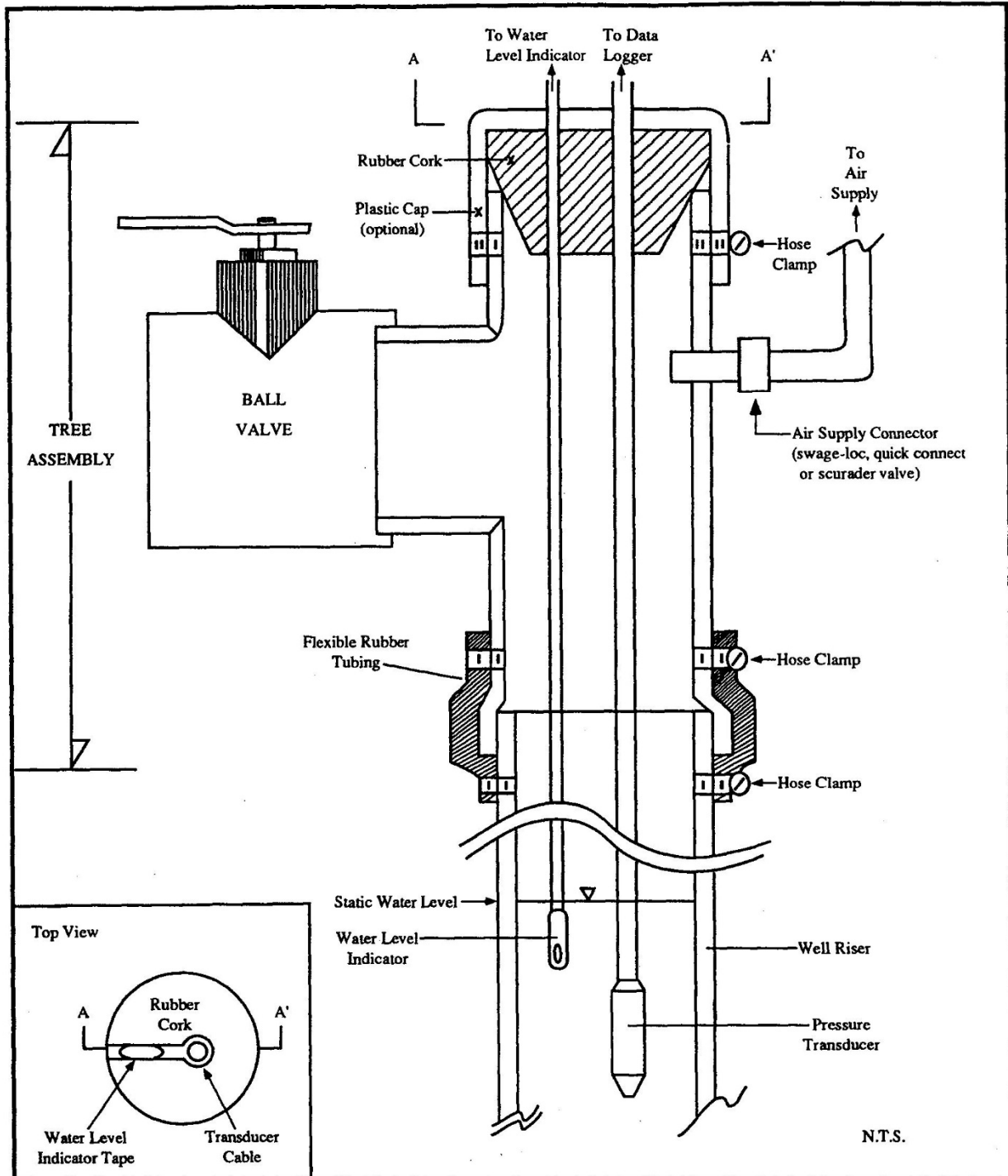

Figure 2

Deletion of Nonessential Data

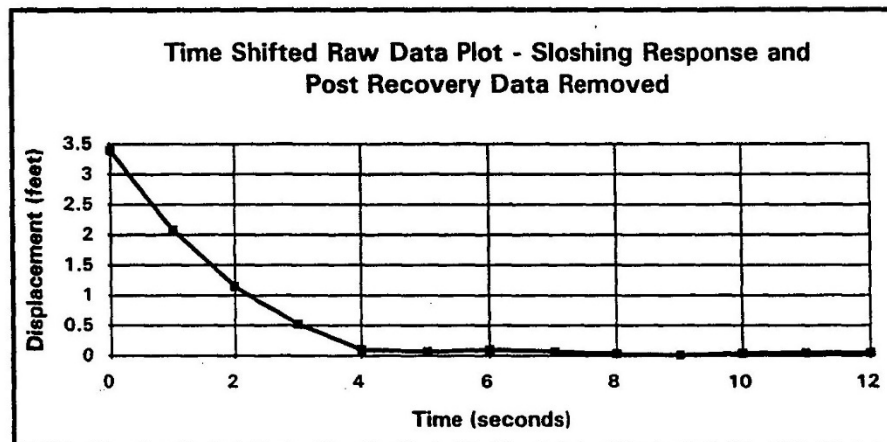
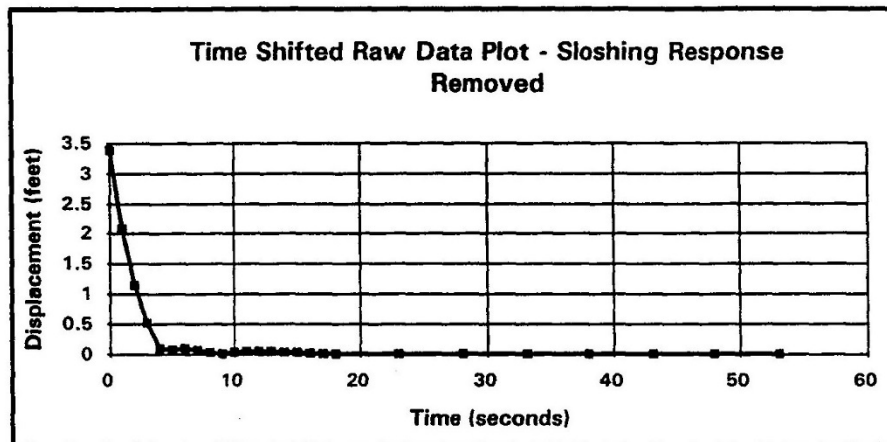
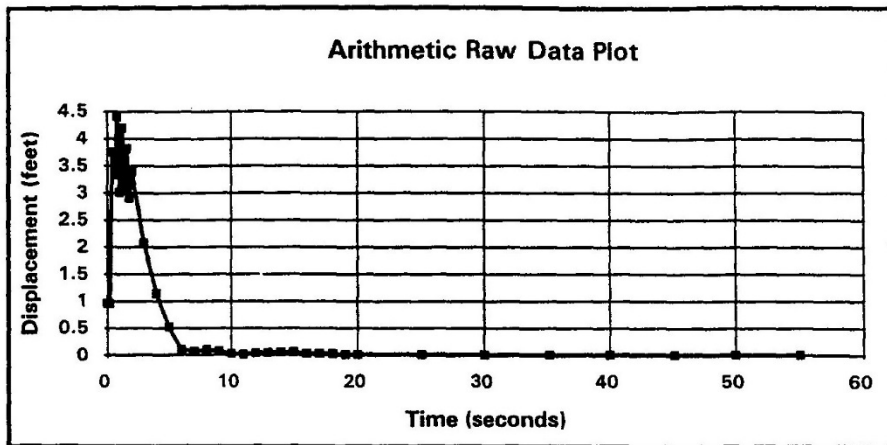
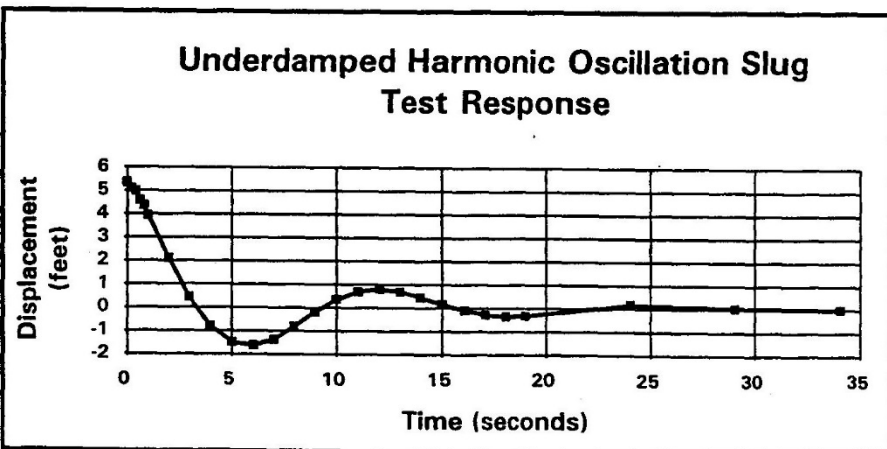
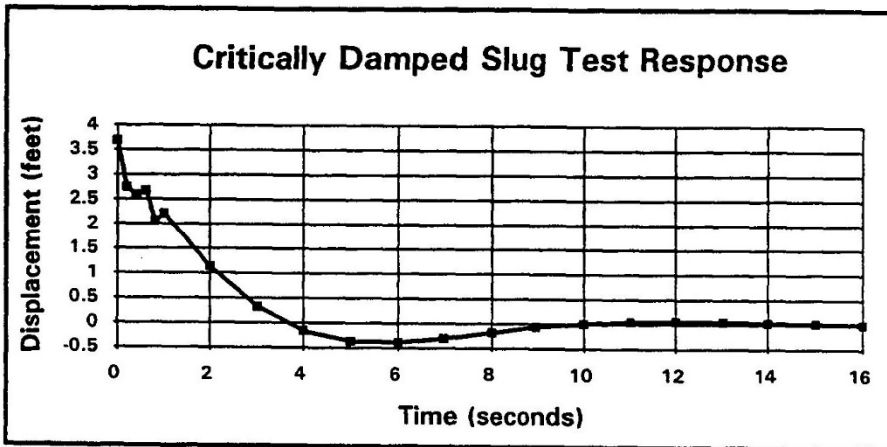
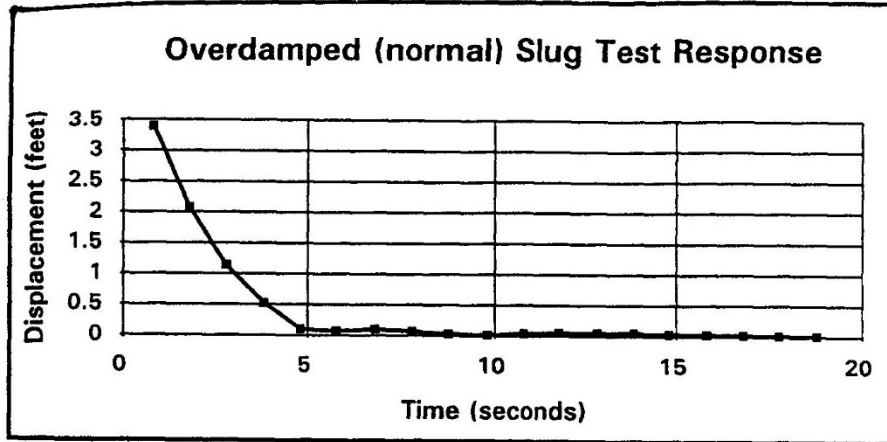

Figure 3

Typical Slug Test Responses



## Aquifer Performance Tests

SOP 4-9

Revision: 2

Date: February 2015

Approved:

  
Signature

Technical Review:

John Dougherty

### 1.0 Objective

The purpose of this technical standard operating procedure (SOP) is to define requirements for conducting a constant rate aquifer performance test (APT).

### 2.0 Background

Many different methods and techniques are performed to determine hydraulic properties of an aquifer (American Society for Testing and Materials 2010). The methods and techniques in this procedure are for a standard constant-rate withdrawal test to be conducted at a nonflowing well. APTs are commonly performed in wells that will ultimately be used to withdraw groundwater for an extended period of time. These wells are typically 6 inches or more in diameter and are used for purposes such as drinking water (a supply well), contaminated groundwater removal (a recovery well), and industrial processes (production well). However, tests can be run in other well types and sizes (e.g., a monitoring well that is 4 inches in diameter). The information collected during an APT is used for defining the hydraulic characteristics of the aquifer. Data collected during an APT can also be used to assess pump selection and water delivery piping.

### 2.1 Definitions

**Pumping well** - The well from which water is withdrawn during an APT.

**Observation well** - A well that is used to monitor the groundwater level at some distance from the pumping well during an APT.

**Stilling pipe** - A small diameter (about 1 inch) pipe that is installed in the pumping well from the top of the pump to the surface; the transducer is placed in the pipe.

### 2.2 Discussion

In general, APTs consist of withdrawing water from a pumping well for a specified time period and monitoring the water level in the pumping well and observation wells. The recorded time-drawdown data are then reduced and analyzed to:

- Determine the specific capacity and safe yield of the well
- Calculate the properties (transmissivity [T] and storativity [S]) of the aquifer (T may be estimated from pumping well and observation well data; S may be estimated from observation well data)
- Characterize the hydrogeologic framework at and near the investigation area

These three items, or one of the items at a minimum, are typically evaluated with APT data. However, other ancillary but useful information (e.g., water quality changes under stressed conditions) may also be obtained from the APT data. During the planning stages of the APT, the objectives of the test shall be specified so that the necessary data to reach the objectives are collected when the test is performed.

### 2.3 Associated SOPs

- SOP 1-6, *Water Level Measurement*
- SOP 1-10, *Field Measurement of Organic Vapors*
- SOP 2-2, *Guide to Handling of Investigation-Derived Waste*
- SOP 4-1, *Field Logbook Content and Control*
- SOP 4-4, *Design and Installation of Monitoring Wells in Aquifers*
- SOP 4-5, *Field Equipment Decontamination at Nonradioactive Sites*

## Aquifer Performance Tests

SOP 4-9

Revision: 2

Date: February 2015

### 3.0 Roles and Responsibilities

**Site Manager** - Translates client's requirements into technical direction of project. Sets technical criteria, reviews, and approves technical progress. Ensures that all participating personnel have proper training. **Note:** Other titles such as project manager may be used.

**Field Team Leader (FTL)** - Supervises field operations. Ensures that all necessary equipment, including safety equipment, is available and functioning properly before project operations begin. Ensures that all necessary personnel are mobilized on time. Maintains daily log of activities each work day.

**Field Geologist** - Collects and maintains data. Coordinates and consults with site manager on decisions relative to unexpected encounters during testing and deviations from this SOP. Directs overall activities of testing procedures and support subcontractors.

### 4.0 Required Equipment

Water measuring and recording:

- Pressure transducers and data logger
- Personal computer for viewing and downloading data
- Water level measuring device
- Stopwatch
- Field logbook
- Decontamination equipment and supplies
- Data on construction of the pumping well (depth to screen and screen length)

Water pumping, treating, storing, and discharging:

- Pump (sufficient capacity to withdraw at the required rate) with electric wiring
- Discharge hosing/piping
- Electrical source (e.g., generator)
- Flowmeter with totalizer
- Sampling valve
- Water treatment unit (if required)
- Water storage container (if required)
- Ancillary equipment and supplies to install and/or operate the main equipment

A field service subcontractor will typically be responsible for providing and operating the equipment for pumping, treating, storing, and discharging water. However, in some cases, it may be appropriate for the pumping, treating, storing, and/or discharging equipment to be provided and operated by those that also provide and operate the water measuring and recording equipment. The project requirements and structure will need to be evaluated to determine the most suitable arrangement for providing and operating the necessary equipment.

### 5.0 Procedures

An APT has five main components:

- Preparation
- Continuous background monitoring
- Step-drawdown test
- Long-term constant rate test
- Discharge water management

Sometimes only the long-term constant rate test is performed and the background monitoring and the step-drawdown tests are omitted. Therefore, the long-term test is sometimes referred to as an APT.

## Aquifer Performance Tests

SOP 4-9

Revision: 2

Date: February 2015

A form that provides typical general information that should be recorded for each test is provided at the end of this SOP.

### 5.1 Preparation

Adequate attention to the planning and design of the APT is a significant phase of the procedure and will ensure that useful results are produced (U. S. Geological Survey 1976, U. S. Environmental Protection Agency 1993). A planning meeting shall be held to identify the objectives of the APT and then the scope of the APT shall be developed. After the objectives are identified and the scope is developed, an APT plan shall be prepared that describes the procedures to be followed. The plan shall identify and describe the details to be followed for each component of the APT.

### 5.2 Continuous Background Monitoring

Water levels shall be collected continuously prior to performing the long-term test. Adjacent surface water bodies should also be monitored. The water levels shall be used to reduce and analyze the data collected during the long-term test. The background data is also useful in characterizing the hydrogeologic framework.

Transducers/loggers shall be installed in the pumping well and the observation wells. Each transducer/logger shall be checked and set following the manufacturer's manual, including setting the internal clock to a common external standard. Each transducer shall be installed to a depth that does not exceed the working capacity of the transducer and where the water level will not drop below the transducer during ambient water level changes. After the selected depth is reached with the transducer:

- Securely attach the cable to the well head and mark a reference point with electrical tape to allow verification that the transducer position does not change during the test
- Read the depth of water using the transducer (note that the transducer may need to equilibrate with the water temperature following the manufacturer's specifications and recover from displacement of water caused by submersion of the transducer)
- Collect a manual water level measurement from the well's measuring point
- Begin recording water levels on a linearly rate of 1 reading per 30 minutes

Transducers shall be programmed so that water level recording begins at the same time at each well. Having water levels recorded at the same time for each well simplifies the data reduction and evaluation activity contrasted to having water levels recorded at different times for different wells.

Background water levels shall be recorded for 7 days. During the monitoring period, the transducers/loggers should be occasionally checked (e.g., check the transducers on day two and day five) to verify that the equipment is working properly. Manual water level measurements should be taken and recorded during this check. Replace any transducer that is identified to be not operating correctly.

At the end of the monitoring period, stop the test recording and download the recorded data.

Barometric pressure (BP) and precipitation shall be recorded during the background monitoring period. These two elements are commonly considered the main natural factors to impact groundwater levels. If publicly available data can be obtained from a weather station located nearby (within approximately 5 miles of the project), the data from that station may be used. BP and precipitation data shall also be recorded during the long-term test.

### 5.3 Step Drawdown Test

The step drawdown test (or simply, step test) is required to determine the constant pumping rate that will be used for the subsequent long-term test and to assess well efficiency. Step test data may also be used to evaluate the hydrogeologic characteristics. The step test is performed at the pumping well. In summary, the step drawdown test consists of pumping water from the well at short incrementally increased rates (steps) so that a withdrawal rate can be determined for the long-term test.



## Aquifer Performance Tests

SOP 4-9

Revision: 2

Date: February 2015

A pump capable of yielding 1.5 times the estimated yield of the pumping well shall be installed to the specified depth. A vertical check valve will be placed in the discharge line immediately above the pump or intake to prohibit water from draining into the well when the pumping ceases. A 1-inch diameter polyvinyl chloride line will be placed in the well with the bottom end open to a depth within 1 foot from the top of the pump. Several ¼-inch diameter holes should be drilled in the bottom 5 feet of this stilling pipe. The water level transducer will be installed in the pipe. After the pumping equipment and transducer are installed, the following steps will be followed:

- Connect a flow meter/totalizer and sample tap with valve to the discharge line from the pump; direct the discharge line to the system to handle the water. Care must be taken to provide sufficient straight sections of pipe above and below the flow meter to obtain accurate measurements. Recent calibration certificates should be obtained for the flow meter.
- Record the volumetric reading on the totalizer (**Note:** Prior to pumping and increasing pumping rate and after ending pumping, the volumetric reading should be recorded).
- Measure and record the static water level in the pumping well.
- Begin logging with the transducer and then start pumping water from the pumping well at a relatively low (approximately ½ of the estimated yield) but steady rate (STEP 1); logging should be started approximately 2 to 5 seconds prior to starting pumping. Flow should be adjusted to maintain a constant rate, noting when changes are made.
- Record the time at which pumping is started, using a clock that is synchronized with the transducer clocks, and the flow rate; check operation of the transducer.
- Monitor the water level in the pumping well with the transducer and confirm periodically with manual measurements.
- After approximately 1½ hours, increase the pumping rate to approximately ¾ of the estimated yield, and continue to monitor the water level for approximately 2 hours (STEP 2).
- Record the time at which the pumping rate is increased and the new flow rate; check operation of the transducer.
- Approximately 2 hours after increasing the pumping rate for STEP 2, increase the pumping rate to approximately equal to the estimated yield, and continue to monitor the water level for approximately 2 hours (STEP 3).
- Record the time at which the pumping rate is increased and the new flow rate.
- Approximately 2 hours after increasing the pumping rate for STEP 3, increase the pumping rate to approximately 1.5 x the estimated yield, and continue to monitor the water level for approximately 2 hours (STEP 4).
- Record the time at which the pumping rate is increased and the new flow rate.
- Shut off the pump at the end of STEP 4 (maximum of 8 hours has elapsed since pumping started at the beginning of the test) and download data. The transducer should continue recording during the recovery period.

A step test is dynamic. During each step the operator will gain more information on how the well's water level responds to specified pumping rates. The estimated increases identified above for each step should only be used as a guide. Each successive increase should be based on the operator's general understanding of well hydraulics, observations made while installing and developing the well, and on the well's response during the previous step(s). The goal, in summary, is to achieve the well yield at STEP 3 and exceed the well yield at STEP 4.

During the test, water levels at the pumping well shall be recorded logarithmically following the recommended schedule in the following chart. Typical data loggers have default sample intervals except for the largest sample interval, which is set by the user (in the table below, the 10-minute sample interval is set by the user). The default sample intervals shall be equal to or similar to the table below.

| <i>Log Cycle</i> | <i>Elapsed Time</i>  | <i>Sample Interval</i> | <i>Points/Cycle</i> |
|------------------|----------------------|------------------------|---------------------|
| 1                | 0 to 20 seconds      | 0.2 second             | 101                 |
| 2                | 20 to 60 seconds     | 1 second               | 40                  |
| 3                | 1 to 10 minutes      | 10 seconds             | 54                  |
| 4                | 10 to 100 minutes    | 2 minutes              | 45                  |
| 5                | 100 to 1,000 minutes | 10 minutes             | 90                  |

## Aquifer Performance Tests

SOP 4-9

Revision: 2

Date: February 2015

The drawdown-time data shall be plotted semi-logarithmically. The drawdown (y-axis) shall be plotted on a linear scale and time (x-axis) shall be plotted on a logarithmic scale. The drawdown curves shall be extrapolated to the specified time of the proposed long-term test. The rate that results in the maximum drawdown without dropping the water level below the design pumping level within the time period of the long-term test shall be considered the flow rate to be used for the long-term test. The specific capacity versus pumping rate should also be plotted to determine if excessive well losses occur at the selected rate.

### 5.4 Long-Term Constant Rate Test

The long-term constant rate test will be performed at the pumping well. Water levels will be monitored in the pumping well and the observation wells. The same pumping equipment used for the step test will be used for the long-term test. BP and precipitation shall be recorded during the long-term test. If publicly available data can be obtained from a weather station located nearby (within approximately 5 miles of the project), the data from that station may be used. Adjacent surface water bodies should also be monitored if the surface water is potentially connected to the groundwater system.

The time interval for the long-term constant rate test shall be specific to the project. However, at a minimum, a confined aquifer should be pumped for 24 hours and an unconfined aquifer to be pumped for 72 hours (American Water Works Association 1997). The project objectives will need to be reviewed and aquifer test solution requirements considered so that the correct pumping period is selected. The following steps shall be followed to conduct the long-term test after the step test is completed.

- Install transducers in the pumping well and the observation wells (note that transducers can be installed in observation wells prior to the day the long-term test starts).
- Read the water level depths with the transducers and record the values; measure and record the static water levels with the electronic water level meter from the wells' measuring points.
- Record the volumetric reading on the totalizer.
- Begin logging water level data with the transducers and then start pumping at the predetermined rate (determined based on the step-drawdown test results).
- Periodically monitor discharge rate and transducers; maintain constant pumping rate.
- Stop pumping at the end of the specified time, record volumetric reading on the totalizer.
- Continue to record water level data with transducers until the water level in the pumping well has recovered so that sufficient data are collected to adequately analyze the recovery or a maximum of 24 hours has elapsed.

The water level data will be transferred to disk form so that it may be reduced, analyzed, and put into report format.

The water levels in the wells will be recorded logarithmically following the recommended schedule in the following chart:

| <i>Log Cycle</i> | <i>Elapsed Time</i> | <i>Sample Interval</i> | <i>Points/Cycle</i> |
|------------------|---------------------|------------------------|---------------------|
| 1                | 0 to 20 seconds     | 0.2 second             | 101                 |
| 2                | 20 to 60 seconds    | 1 second               | 40                  |
| 3                | 1 to 10 minutes     | 10 seconds             | 54                  |
| 4                | 10 to 100 minutes   | 2 minutes              | 45                  |
| 5                | >100 minutes        | 10 minutes             | unspecified         |

When the pump is shut off and recovery begins, a new logarithmic series will be started for the transducer in the pumping well. The series shall be started 1 to 5 seconds prior to ending the pumping activity. The transducers in the observation wells will continue to monitor on the first logarithmic cycle series. If the aquifer is expected to recover quickly, the observation well transducers may also be restarted on a new series. Data will be recorded until the water level in the pumping well has returned so that sufficient data are collected to adequately analyze the recovery or until a maximum of 24 hours has elapsed. A manual water level measurement shall be collected from the wells, measuring points, and a reading should be taken with the transducers during recovery.

At the conclusion of the recovery test, the data logging shall be stopped at each well and the transducers shall be removed and the data downloaded.

## Aquifer Performance Tests

SOP 4-9

Revision: 2

Date: February 2015

### 5.5 Discharge Water Management

The water pumped from the well shall be discharged and managed following the plan specific to the project. Several methods may be used to handle the discharge water from an APT. The water may be discharged:

- Directly to the ground surface or a water body, if permitted by the regulatory agencies. Such discharge should be at a sufficient distance from the pumping and observation wells so that the test is not impacted if water infiltrates to the aquifer.
- To a holding tank, sampled and analyzed after the test, and then released to the ground surface or water body after analytical results prove that discharge requirements are met.
- To a unit designed and constructed to treat the water to meet discharge criteria; treated and then released to the ground surface or water body.

Also, a combination of the three options above may be used. Other discharge options may also be available and followed.

In summary, several different methods are typically available to handle discharge water. The governing agency shall be contacted so that required water handling practices are followed and discharge criteria are met.

### 6.0 Data Reduction and Analysis

The data sets from an APT are typically very robust. The data may be reduced and analyzed to:

- Determine the specific capacity and safe yield of the well
- Calculate the properties (T and S) of the aquifer
- Characterize the hydrogeologic framework at and near the investigation area

These three items, or one of the items at a minimum, are typically evaluated with APT data. Other pumping test data may also be available and evaluated.

APT data are recommended to be analyzed with computer software; however, data may also be analyzed manually. The groundwater modeling tool kit contains Aquifer<sup>Win32</sup> (ESI International), which is a program that may be used to assist in analyzing test data. Other programs are also available. Software packages are useful since they can be used to manage a significant amount of data in short time periods and contain many different confined and unconfined test solutions. The trained user can use these benefits to generate detailed response curve graphs, precise hydraulic values, and insights into the hydrogeologic framework near the well. Regardless of the analytical method employed or whether the data is analyzed manually or by computer, the analyst should review the original technical paper or textbook summary of the method in order to understand the mechanics and assumptions underlying the method prior to attempting any analysis and verify the method is appropriate for the site conditions.

APT data analyses and hydraulic property calculations shall be performed by an experienced professional, documented in a calculation brief, and reviewed. Data analysis and parameter calculations are beyond the scope of this SOP and, therefore, are not discussed here.

### 7.0 Restrictions/Limitations

This procedure describes the standard steps used to conduct a constant rate APT. Since APTs are complex and project objectives and site requirements vary, not every step or possible method was incorporated into the procedure.

A planning meeting shall be held to identify the objectives of the APT, then the scope of the APT shall be developed. After the objectives are identified and the scope is developed, an APT plan shall be prepared that describes the project-specific procedures to be followed. The plan shall describe the details to be followed for each component of the APT. The objectives of the test shall be specified so that the necessary data to reach the objectives are collected when the test is performed.

## Aquifer Performance Tests

SOP 4-9  
Revision: 2  
Date: February 2015

### 8.0 References

American Society for Testing and Materials. 2010. Standard Guide for Selection of Aquifer Test Method in Determining Hydraulic Properties by Well Techniques. D 4043-96 (Reapproved 2010).

American Water Works Association. 1997. AWWA Standard for Water Wells (ANSI/AWWA A 100-97).

ESI International, see their website, <http://esinternational.com>, for current information on Aquifer<sup>win32</sup>

U. S. Environmental Protection Agency. 1993. Ground Water Issue Suggested Operating Procedures for Aquifer Pumping Tests (EPA/540/S-93/503). February.

U. S. Geological Survey. 1976. Techniques of Water-Resources Investigations of the United States Geological Survey: Chapter B1 Aquifer Test Design, Observation and Data Analysis.



**Borehole and Well Decommissioning**

SOP 4-10

Revision: 2

Date: February 2015

Approved:

  
Signature

Technical Review:

David Schroeder

**1.0 Objective**

The purpose of this technical standard operating procedure (SOP) is to provide guidelines for the decommissioning of boreholes and wells. These guidelines help to produce consistency of approach in the planning and implementation of borehole and well decommissioning. Individual decommissioning procedures shall probably vary in some respects as a result of varying borehole or well construction materials and methods and regulatory framework.

**2.0 Background****2.1 Definitions**

**Note:** The definitions provided are generalized. Definitions are often codified in state or local regulations and should be verified against the definitions presented in this SOP before commencement of work.

**Decommissioning** - The engineered closure of a well, borehole, or other subsurface monitoring device sealed with plugging materials. Decommissioning also includes the planning and documentation of all associated activities. Common synonyms for “decommissioning” include “destroying,” “plugging,” and “abandoning,” and the term used can vary between regulatory agencies.

**Grout** - Material consisting of bentonite, cement, or a cement-bentonite mixture.

**Overdrilling** - The process of drilling out a well casing and any material placed in the annular space.

**Plugging Material** - A material that has a hydraulic conductivity equal to or less than that of the geologic formation(s) to be sealed. Typical materials include portland cement and bentonite.

**Tremie Pipe** - A pipe or tube that is used to transport cement, bentonite, or other plugging materials from the ground surface to a specified depth in a borehole or well. The material may be allowed to flow freely or it may be injected under pressure.

**Well Casing** - Impervious durable pipe placed in a well to prevent the borehole walls from caving and to help seal off surface drainage or undesirable water, gas, or other fluids from entering the well.

**2.2 Associated Procedures**

- SOP 2-2, *Guide to Handling of Investigation-Derived Waste*
- SOP 3-5, *Lithologic Logging*
- SOP 4-1, *Field Logbook Content and Control*
- SOP 4-2, *Photographic Documentation of Field Activities*
- SOP 4-4, *Design and Installation of Monitoring Wells in Aquifers*
- SOP 4-5, *Field Equipment Decontamination at Nonradioactive Sites*

**2.3 Discussion**

This SOP is intended to cover the decommissioning of boreholes during environmental investigations and remediation efforts. It is intended to be a general guideline listing the types of materials and methods to be considered when a borehole or well is decommissioned. Materials are not specified in detail since it is likely there will be wide variability required to meet the needs of individual site conditions, specific clients, and regulatory requirements. If there is a conflict between this

SOP and procedures given by the federal, state, and/or local regulatory agencies involved in the decommissioning process, the materials and procedures given by the regulatory agencies shall take precedence.

**Borehole and Well Decommissioning**

SOP 4-10

Revision: 2

Date: February 2015

**3.0 General Responsibilities**

**Field Team Leader** - The field team leader (FTL) is responsible for ensuring that borehole and well decommissioning activities are conducted in accordance with this SOP and any site-specific work plans, scopes of work, quality assurance plan, and site health and safety plan.

**Field Geologist** - The field geologist is responsible for understanding and implementing this SOP during all field activities, as well as obtaining the appropriate permits, field logbooks, forms, and records necessary to complete the field activities. The field geologist collects and maintains data by providing oversight of the decommissioning procedures by the drilling subcontractor and completing the CDM Smith Borehole/Well Decommissioning Record (Figure 1). The field geologist coordinates and consults with the FTL on decisions relative to unexpected encounters during field activities and deviations from this SOP. The field geologist directs overall activities of drill and support subcontractors.

**Drilling Subcontractor** - The drilling subcontractor provides the necessary equipment and materials for borehole and monitoring well decommissioning. This generally includes a drill rig or service truck with grouting equipment and appropriate backfill materials such as portland cement, potable water, and bentonite powder and/or chips. The drilling subcontractor is responsible for submitting forms and records required by law or regulations to the applicable state and/or local regulatory agency and as required in the subcontractor statement of work.

**Note:** Responsibilities may vary from site to site. Therefore, all field team member responsibilities shall be defined in the field plan or site-/project-specific quality assurance plan.

**4.0 Required Equipment and Materials****4.1 Required Field Equipment and Supplies**

- Water level indicator
- Personal protective equipment (PPE)
- Tape measure (weighted tip)
- Camera
- Health and safety equipment
- Explosimeter, OVA (FID) or OVM per health and safety plan
- Bound field logbook
- CDM Smith Borehole/Well Abandonment Form
- Backfill materials (e.g., portland cement, potable water, and bentonite powder and/or chips)
- Global positioning system (GPS) equipment (if required)
- Downhole video equipment (if required)

**4.2 Required Construction Materials**

**Note:** The materials that are used in the decommissioning of a borehole or well and that come in contact with groundwater shall not measurably alter the chemical quality of the groundwater source.

**Water** - Water, which may be used in the well decommissioning process, shall be obtained from a source that does not contain constituents that could compromise groundwater quality. A certificate of analysis should be provided with the water, potable water from an approved source should be used, or a sample of the water should be analyzed and documented as contaminant-free.

**Plugging Materials** - The materials used to plug the borehole or well casing may be prepared as a slurry or used unmixed in a dry pellet form, depending on the application. Plugging materials shall be selected for compatibility with local geologic, hydrogeologic, climatic, and human-induced conditions in the subsurface.

**Borehole and Well Decommissioning**

SOP 4-10

Revision: 2

Date: February 2015

**Grout** - The grout used for decommissioning boreholes or wells shall be a liquid slurry consisting of water, bentonite of Volclay or equivalent quality, and/or portland cement. Bentonite-based grout is typically used when a more flexible grout is desired (i.e., freeze-thaw). Cement-based grout provides a more rigid plugging material. A typical bentonite slurry mixture is a minimum 20 percent solids slurry by weight. Cement-bentonite grout is typically 6 to 7 gallons of water per 94 pound bag of Type I portland cement and 2.7 percent bentonite powder.

**Bentonite** - Bentonite shall be powdered, chipped, or pelletized sodium montmorillonite furnished in sacks or buckets from a commercial source and free of impurities that adversely impact water quality in the subsurface. Pellets or chips are typically used for plugging shallow boreholes and powdered bentonite is used for mixing in grout.

**Cement** - Each type of cement has slightly different characteristics that may be appropriate under various physical and chemical conditions. Cement shall generally be portland Type I, Type II, or Type I/II as specified in ASTM C 150. Quicksetting cements containing additives are not allowable for use in decommissioning. Additives may leach from the cement and influence the chemistry of the groundwater.

**Tremie Pipe** - A tremie pipe is used to inject grout-based plugging materials. Tremie pipes are typically constructed of PVC or galvanized steel. Associated equipment may include a trough or mixing box and "mud pump" to place the material.

## 5.0 Procedures

The actual methods of decommissioning boreholes or wells at a site vary depending on site conditions and the construction materials and methods used during the original installation. The method to be used at a site shall be stated in the site-specific plans. Deviations from the methods prescribed in these plans shall be approved by the FTL or designee.

A description of plugging materials, volume calculations, and/or overdrilling observations needs to be recorded on the CDM Smith Borehole/Well Decommissioning Form (Figure 1) or in a logbook (SOP 4-1).

### 5.1 Pre-Decommissioning Preparation

Well construction records (if available) should be obtained before field mobilization to understand the construction of the wells requiring decommissioning. Records are used to verify depths and construction materials within the well before start of decommissioning activities and as decommissioning activities are completed. The records may also be required by state and/or local regulatory agencies as part of the decommissioning permitting process.

State or local regulations may require either pre- and post-notification or a permit during borehole or well decommissioning activities; each borehole or well at a site may require individual notification and/or permits. Before initiating field work, state and local regulations shall be researched and the notification and/or permitting procedures provided by the regulatory agencies shall be followed. Some state and local regulations require the driller or drilling company licensed in the jurisdiction to submit the required decommissioning paperwork and obtain the permits from the regulatory agencies. The drilling subcontractor statement of work should clearly designate whether the subcontractor or CDM Smith is responsible for submitting decommissioning paperwork to the regulatory agencies in accordance with the regulations.

### 5.2 Borehole or Well Inspection

Before decommissioning, each borehole or well shall be inspected for obstructions (including but not limited to pumps, sampling equipment, debris, and other undesirable materials that might interfere with decommissioning) and remove them. Disposal of materials removed from boreholes or wells shall be in accordance with the site-specific plans and SOP 2-2.

Total depth of the borehole or well should be verified using a weighted tape, compared to any records obtained from original borehole or well installation, and recorded on the CDM Smith Borehole/Well Decommissioning Form (Figure 1) or in a logbook (SOP 4-1). The preexisting condition of the borehole or well prior to decommissioning shall be recorded in the logbook and photographed in accordance with SOP 4-2. Some state or local regulatory agencies may have additional pre-decommissioning requirements such as field location of the borehole or well using GPS equipment or downhole video inspection of the well before decommissioning. This information should also be recorded on the borehole/well decommissioning form and in the logbook.



**Borehole and Well Decommissioning**

SOP 4-10

Revision: 2

Date: February 2015

**5.3 Well Overdrilling (Not Applicable to Borehole Decommissioning)**

The requirement for overdrilling wells during decommissioning shall vary to meet the needs of individual site conditions, specific clients, and regulatory requirements. Some state and local regulatory agencies require all well construction materials to be removed from the borehole using an overdrilling method before the remaining borehole can be plugged. It is generally preferable to pull the well casing from the subsurface by overdrilling the annular space of the well and remove the casing in whole sections. Site-specific conditions and well construction materials may preclude removal of all casing materials using an overdrilling/pulling method.

The actual methods for overdrilling wells at a site shall vary depending on site conditions and the construction materials and methods used during the original well installation. The method to be used at a site shall be stated in the site-specific plans. Deviations from the methods prescribed in these plans shall be approved by the FTL or designee. Typical overdrilling methods include air rotary, mud/fluid rotary, roto-sonic, and hollow-stem auger. Drilling with mud or water is least desirable, but the driller shall have the capability to use this method if well conditions warrant it. The wells shall be overdrilled to the well depth specified in the site-specific plans but may vary based on actual well construction depth (determined in the field) required to remove well construction materials. Drillers must prevent grease, oil, and other fluids from the drill rig from coming in contact with the ground around the area of well installation. Disposal of materials removed from wells shall be in accordance with the site-specific plans and SOP 2-2.

A description of overdrilling observations needs to be recorded on the CDM Smith Borehole/Well Decommissioning Form (Figure 1) or in a logbook (SOP 4-1). Unusual conditions or materials observed during overdrilling shall be photographed in accordance with SOP 4-2.

**5.4 Borehole or Well Plugging**

The following processes apply to both boreholes and wells. It should be noted that plugging processes shall vary with the total depth of the borehole or well and/or the type of well construction. Generally, plugging using bentonite pellets or chips is only allowable for shallow boreholes less than 10 feet below ground surface (bgs). Chips should not be used for plugging small-diameter boreholes because of bridging concerns due to their angular shape. The method to be used at a site for a particular borehole or well shall be stated in the site-specific plans. Deviations from the methods prescribed in these plans shall be approved by the FTL or designee.

The CDM Smith field geologist shall calculate the amount of plugging material needed to fill the borehole or well casing to complete decommissioning. These calculations should be completed in the field after borehole or well depths and dimensions have been inspected and verified. The volume and depth of plugging materials used for borehole or well decommissioning shall be documented on the CDM Smith Borehole/Well Decommissioning Form (Figure 1) or in a logbook (SOP 4-1).

**5.4.1 Plugging Using Bentonite Pellets or Chips**

Boreholes completed to a depth less than 10 feet may be backfilled with bentonite pellets or chips and hydrated until the pellets or chips come within 6 inches of the surface. The chips shall be installed by gravity feed down the center of the borehole. The depth of the pellets or chips shall be tracked using a weighted tape to ensure there is no bridging. The chips shall be hydrated at 2-foot intervals using sufficient quantities of clean water to allow for adequate saturation and expansion of the bentonite.

**5.4.2 Plugging Using Grout**

Boreholes greater than 10 feet in depth and wells shall be plugged using grouting methods. A sufficient volume of grout shall be premixed onsite, according to procedure stipulated by the manufacturer, to compensate for unexpected losses to the formation. This process shall be checked against the calculated volume of the borehole or well casing to be decommissioned to ensure that bridging does not occur during emplacement. The use of alternate grout materials, including grout containing portland cement, may be necessary to control zones of high grout loss. The mixing (and placing) of grout shall be performed with recorded weights and volumes of materials, according to procedures stipulated by the manufacturer. Lumpy grout shall not be used in an effort to prevent bridging within the tremie and the well. Bentonite-based grout of Volclay or equivalent type shall be mixed to the manufacturer's specifications and then pumped into place using minimum pump pressure. All additives to grouts shall be evaluated for their effects on the subsurface.

**Borehole and Well Decommissioning**

SOP 4-10

Revision: 2

Date: February 2015

Depending upon the borehole or well depth and/or construction, plugging may be accomplished using a pressure grouting technique or by gravity feed through a tremie pipe. With either method, grout is introduced in one continuous operation until grout flows out at the ground surface without evidence of drill cuttings or fluid. The grout shall be injected under pressure using a tremie pipe when possible to reduce the possibility of leaving voids in the annular seal and to displace any liquids or drill cuttings that may remain in the borehole or well casing. The tremie pipe shall be kept full of grout from start to finish with the discharge end of the pipe completely submerged as it is slowly and continuously lifted. Pump pressure shall be kept to a minimum.

Approximately 5 to 10 feet of tremie pipe shall remain submerged during grout emplacement. If possible, steel tape soundings shall be made to ensure the level of the tremie material is in agreement with the calculated volume and that the desired placement of plugging materials is achieved. A staged grouting procedure may be considered if there is significant grout loss into the formation because of the weight exerted by the full column of grout as it sets. If used for borehole or well drilling, temporary casing or hollow-stem augers shall be removed in increments (immediately following each lift of grout installation) well in advance of the time when the grout begins to set. The initial grout mixture must be allowed to cure for approximately 24 hours, then checked and refilled to within 6 inches of the surface.

**5.5 Surface Restoration**

Surface completion materials for wells (such as protective casing, bumper posts, and concrete pads) should be removed to the extent possible. If overdrilling is required, removal of surface completion materials shall be performed before the overdrilling operation. Well and surface casings (if left in the subsurface) should be removed to an approximate depth of 2 feet bgs before surface restoration. Disposal of materials removed from wells shall be in accordance with the site-specific plans and SOP 2-2.

The upper 6 inches of the borehole or well that has been decommissioned shall be completed with similar surface material (i.e., sod, asphalt, concrete) as the surrounding area. In the case of soil boreholes completed in an area absent of surface material, the overlying soil shall be used to backfill the remaining 6 inches of the borehole until flush with the surrounding surface.

**5.6 Post Operation Procedures****5.6.1 Field Procedures**

At the conclusion of the borehole or well decommissioning activities, all equipment coming in contact with the subsurface must be decontaminated (according to SOP 4-5) before moving the equipment to a different work location. All water used in the decontamination of equipment shall be contained in an appropriate container, if required in the site-specific plans. Disposal of decontamination water shall be in accordance with the site-specific plans and SOP 2-2.

**5.6.2 Documentation**

The CDM Smith Borehole/Well Decommissioning Form (Figure 1) shall be completed by the CDM Smith field geologist or designee at the conclusion of the field activity. Any post-notification or decommissioning paperwork to be submitted to regulatory agencies shall be completed by the drilling subcontractor or CDM Smith designee as required by regulations.

Copies of all field notes, the daily logs, and the CDM Smith Borehole/Well Decommissioning Forms shall be given to the FTL. These records shall be maintained in the project and document control files. At a minimum, all materials used for decommissioning shall be documented by entering identifying numbers (lot numbers, manufacturer's identification, etc.) in the field logbook and on the CDM Smith Borehole/Well Decommissioning Form. Samples of decommissioning materials (including grout, sand, etc.) may be archived if specified in the site-specific plans.

**6.0 Restrictions/Limitations**

Check with the federal, state, and local agencies for specific decommissioning procedures. If no specific decommissioning procedures are identified, the decommissioning materials and methods provided in this procedure shall be followed.

**Borehole and Well Decommissioning**

SOP 4-10  
Revision: 2  
Date: February 2015

**7.0 References**

American Society for Testing and Materials (ASTM). 1999 (Reapproved 2012)e1. *Standard Guide for Decommissioning Ground Water Wells, Vadose Zone Monitoring Devices, Boreholes, and Other Devices for Environmental Activities*. Standard Method D 5299-99.

U. S. Army Corps of Engineers (USACE). Nov. 1, 1998. *Engineering Manual (EM) 1110-1-4000. Monitoring Well Design, Installation, and Documentation at Hazardous, Toxic, and Radioactive Waste Sites*.

*Example*

**CDM  
Smith** Borehole/Well Decommissioning Record

Borehole/Well Identification No. \_\_\_\_\_

**Facility or Project Area:** \_\_\_\_\_ **Site:** \_\_\_\_\_ **Job No:** \_\_\_\_\_

**Recorded By:** \_\_\_\_\_ **Date:** \_\_\_\_\_ **Checked By:** \_\_\_\_\_

Borehole/Well Decommissioning Permit No. (if applicable): \_\_\_\_\_

Regulatory/Permitting Agency: \_\_\_\_\_ Contact: \_\_\_\_\_ Phone No.: \_\_\_\_\_

Original Borehole/Well Construction Records Available and Reviewed? (Attach) Yes \_\_\_ No \_\_\_

Condition of Borehole/Well at Ground Surface before Decommissioning: \_\_\_\_\_

\_\_\_\_\_  
 \_\_\_\_\_

Maximum Depth Measured in Borehole/Well: \_\_\_\_\_ Datum: \_\_\_\_\_

Original Borehole/Well Bore Depth from Records (if available): \_\_\_\_\_

Downhole Obstruction Indicated? Yes \_\_\_ No \_\_\_

If yes, describe the method(s) used to assess the nature of the obstruction and/or methods to remove it: \_\_\_\_\_

\_\_\_\_\_  
 \_\_\_\_\_

Depth (feet) to Water before Borehole/Well Decommissioning: \_\_\_\_\_ Datum: \_\_\_\_\_

Date of water level measurement: \_\_\_\_\_

Any Indications of Borehole/Well Contamination? Yes \_\_\_ No \_\_\_

If yes, describe field evidence suggesting borehole/well contamination: \_\_\_\_\_

\_\_\_\_\_  
 \_\_\_\_\_

Plugging/Sealing Material Used for Decommissioning and Corresponding Depth Intervals:

| Plugging Material | From  | To    | Qty. Sacks<br>Cement | Qty. Sacks<br>Sand | Qty. Sacks<br>Bentonite | Qty. Sacks<br>Aggregate | Qty. Gal.<br>Water |
|-------------------|-------|-------|----------------------|--------------------|-------------------------|-------------------------|--------------------|
| _____             | _____ | _____ | _____                | _____              | _____                   | _____                   | _____              |
| _____             | _____ | _____ | _____                | _____              | _____                   | _____                   | _____              |
| _____             | _____ | _____ | _____                | _____              | _____                   | _____                   | _____              |
| _____             | _____ | _____ | _____                | _____              | _____                   | _____                   | _____              |

Manufacturer/Supplier Information for Plugging Materials:

Surface Restoration Materials (describe): \_\_\_\_\_ From: \_\_\_\_\_ To: \_\_\_\_\_

\_\_\_\_\_  
 \_\_\_\_\_

**Comments:**  
 \_\_\_\_\_  
 \_\_\_\_\_  
 \_\_\_\_\_

**Control of Measurement and Test Equipment**

SOP 5-1

Revision: 10

Date: February 2015

Approved:

  
Signature

Technical Review:

Stuart Barden

**1.0 Objective**

The objective of this technical standard operating procedure (SOP) is to establish the baseline requirements, procedures, and responsibilities inherent to the control and use of all measurement and test equipment (M&TE). Contractual obligations may require more specific or stringent requirements that must also be implemented.

**2.0 Background****2.1 Definitions**

**Traceability** - The ability to trace the history, application, or location of an item and like items or activities by means of recorded identification.

**2.2 Associated Procedures**

- SOP 4-1, *Field Logbook Content and Control*
- CDM Smith Quality Procedures (QPs) 2.1 and QP 6.3
- Manufacturer's operating and maintenance and calibration procedures

**2.3 Discussion**

M&TE may be government furnished (GF), rented or leased from an outside vendor, or purchased. It is essential that measurements and tests resulting from the use of this equipment be of the highest accountability and integrity. To facilitate that, the equipment shall be used in full understanding and compliance with the instructions and specifications included in the manufacturer's operations and maintenance and calibration procedures and in accordance with any other related project-specific requirements.

**3.0 Responsibilities**

All staff with responsibility for the direct control and/or use of M&TE are responsible for being knowledgeable of and understanding and implementing the requirements contained herein as well as any other related project-specific requirements.

The project manager (PM) or designee (equipment coordinator, quality assurance coordinator, field team leader, etc.) is responsible for initiating and tracking the requirements contained herein.

**Note:** Responsibilities may vary from site to site. Therefore, all field team member responsibilities shall be defined in the field plan or site-/project-specific quality assurance plan.

**4.0 Requirements for M&TE**

- Determine and implement M&TE related project-specific requirements
- The maintenance and calibration procedures must be followed when using M&TE
- Obtain the maintenance and calibration procedures if they are missing or incomplete
- Attach or include the maintenance and calibration procedures with the M&TE
- Prepare and record maintenance and calibration in an equipment log or a field log as appropriate (Figure 1)
- Maintain M&TE records
- Label M&TE requiring routine or scheduled calibration (when required)
- Perform maintenance and calibration using the appropriate procedure and calibration standards
- Identify and take action on nonconforming M&TE

## Control of Measurement and Test Equipment

SOP 5-1

Revision: 10

Date: February 2015

### 5.0 Procedures

#### 5.1 Determine if Other Related Project-Specific Requirements Apply

**For all M&TE:**

The PM or designee shall determine if M&TE related project-specific requirements apply. If M&TE related project-specific requirements apply, obtain a copy of them and review and implement as appropriate.

#### 5.2 Obtain the Operating and Maintenance and Calibration Documents

**For GF M&TE that is to be procured:**

**Requisitioner** - Specify that the maintenance and calibration procedures be included.

**For GF M&TE that is acquired as a result of a property transfer:**

**Receiver** - Inspect the M&TE to determine whether maintenance and calibration procedures are included with the item. If missing or incomplete, order the appropriate documentation from the manufacturer.

**For M&TE that is to be rented or leased from an outside vendor:**

**Requisitioner** - Specify that the maintenance and calibration procedures, the latest calibration record, and the calibration standards certification be included. If this information is not delivered with the M&TE, ask the procurement division to request it from the vendor.

#### 5.3 Prepare and Record Maintenance and Calibration Records

**For all M&TE:**

**PM or Designee** - Record all maintenance and calibration events in a field log unless other project-specific requirements apply.

**For GF M&TE only (does not apply to rented or leased M&TE):**

If an equipment log is a project specific requirement, perform the following:

**Receiver** - Notify the PM or designee for the overall property control of the equipment upon receipt of an item of M&TE.

**PM or Designee and User:**

- Prepare a sequentially page numbered equipment log for the item using the maintenance and calibration form (or equivalent) (Figure 1).
- Record all maintenance and calibration events in an equipment log.

#### 5.4 Label M&TE Requiring Calibration

**For GF M&TE only (does not apply to rented or leased M&TE):**

If calibration labeling is a project specific requirement, perform the following:

**PM or Designee:**

- Read the maintenance and calibration procedures to determine the frequency of calibration required.
- If an M&TE item requires calibration before use, affix a label to the item stating "Calibrate Before Use."
- If an M&TE item requires calibration at other scheduled intervals, e.g., monthly, annually, etc., affix a label listing the date of the last calibration, the date the item is next due for a calibration, the initials of the person who performed the calibration, and a space for the initials of the person who shall perform the next calibration.

#### 5.5 Operating, Maintaining or Calibrating an M&TE Item

**For all M&TE:**

**PM or Designee and User** - Operate, maintain, and calibrate M&TE in accordance with the manufacturer's maintenance and calibration procedures. Record maintenance and calibration actions in the equipment log or field log.

## Control of Measurement and Test Equipment

SOP 5-1

Revision: 10

Date: February 2015

### 5.6 Shipment

#### For GF M&TE:

**Shipper** - Inspect the item to ensure that the maintenance and calibration procedures are attached to the shipping case, or included, and that a copy of the most recent equipment log entry page (if required) is included with the shipment. If the maintenance and calibration procedures and/or the current equipment log page (if required) is missing or incomplete, do not ship the item. Immediately contact the PM or designee and request a replacement.

#### For M&TE that is rented or leased from an outside vendor:

**Shipper** - Inspect the item to ensure that the maintenance and calibration procedures and latest calibration and standards certification records are included prior to shipment. If any documentation is missing or incomplete, do not ship the item. Immediately contact the procurement division and request that they obtain the documentation from the vendor.

Note that some M&TE equipment must remain upright to maintain calibration. Such M&TE should be shipped only in containers labeled appropriately with "This End Up" labels.

**Receiver** – Some M&TE equipment must remain upright to maintain calibration. Upon receipt, inspect the container to verify that it is upright per "This End Up" labels. If it is not upright, notify the PM and vendor.

### 5.7 Records Maintenance

#### For GF M&TE:

**PM or Designee** - Create a file upon the initial receipt of an item of M&TE or calibration standard. Organize the files by contract origin and by M&TE item and calibration standard. Store all files in a cabinet, file drawer, or other appropriate storage media at the pertinent warehouse or office location.

**Receiver** - Forward the original packing slip to the procurement division and a photocopy to the PM or designee.

#### **PM or Designee and User:**

- Maintain all original documents in the equipment file except for the packing slip and field log.
- File the photocopy of the packing slip in the M&TE file.
- Record all maintenance and calibration in an equipment log or field log (as appropriate). File the completed equipment logs in the M&TE records. Forward completed field logs to the PM for inclusion in the project files.

#### For M&TE rented or leased from an outside vendor:

**Receiver** - Forward the packing slip to the procurement division.

#### **User:**

- Forward the completed field log to the PM for inclusion in the project files.
- Retain the most current maintenance and calibration record and calibration standards certifications with the M&TE item and forward previous versions to the PM for inclusion in the project files.

### 5.8 Traceability of Calibration Standards

#### For all items of M&TE:

#### **PM or Designee and User:**

- When ordering calibration standards, request nationally recognized standards as specified or required. Request commercially available standards when not otherwise specified or required. Or, request standards in accordance with other related project-specific requirements.
- Require certifications for standards that clearly state the traceability.
- Require Material Safety Data Sheets to be provided with standards.
- Note standards that are perishable and consume or dispose of them on or before the expiration date.

## Control of Measurement and Test Equipment

SOP 5-1

Revision: 10

Date: February 2015

### 5.9 M&TE That Fails Calibration

For any M&TE item that cannot be calibrated or adjusted to perform accurately:

#### PM or Designee

- Immediately discontinue use and segregate the item from other equipment. Notify the appropriate PM and take appropriate action. in accordance with the CDM Smith QP 6.3 for nonconforming items.
- Review the current and previous maintenance and calibration records to determine if the validity of current or previous measurement and test results could have been affected and notify the appropriate PM(s) of the results of the review.

### 6.0 Restrictions/Limitations

On an item-by-item basis, exemptions from the requirements of this SOP may be granted by the Headquarters health and safety manager and/or Headquarters quality assurance director. All exemptions shall be documented by the grantor and included in the equipment records as appropriate.

### 7.0 References

CDM Federal Programs Corporation. 2012. *Quality Assurance Manual*. Rev. 13.

American National Standard. 2004. *Quality Systems for Environmental Data and Technology Programs – Requirements with Guidance for Use*. ANSI/ASQ E4-2004



**Control of Measurement and Test Equipment**

SOP 5-1  
Revision: 10  
Date: February 2015

**Figure 1**

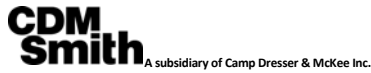

**Maintenance and Calibration**

|  |  |  |  |
|--|--|--|--|
| Date: _____  |  | Time: (a.m./p.m.) _____                        |  |
| Employee Name: _____   |  | Equipment Description: _____                   |  |
| Contract/Project: _____  |  | Equipment ID No.: _____                        |  |
| Activity: _____  |  | Equipment Serial No.: _____                    |  |
| <b>Maintenance</b>   |  |  |  |
| Maintenance Performed: _____   |  |  |  |
| _____  |  |  |  |
| Comments: _____  |  |  |  |
| _____  |  |  |  |
| Signature: _____   |  | Date: _____                                    |  |
| <b>Calibration/Field Check</b>   |  |  |  |
| Calibration Standard: _____  |  | Concentration of Standard: _____               |  |
| Lot No. of Calibration Standard: _____                                       |  | Expiration Date of Calibration Standard: _____ |  |
| Pre-Calibration Reading: _____   |  | Post-Calibration Reading: _____                |  |
| Additional Readings: _____   |  | Additional Readings: _____                     |  |
| Additional Readings: _____   |  | Additional Readings: _____                     |  |
| Pre-Field Check Reading: _____   |  | Post-Field Check Reading: _____                |  |
| Adjustment(s): _____   |  |  |  |
| _____  |  |  |  |
| Calibration: <input type="checkbox"/> Passed <input type="checkbox"/> Failed |  |  |  |
| Comments: _____  |  |  |  |
| _____  |  |  |  |
| Signature: _____   |  | Date: _____                                    |  |



# Certificate of Completion

THIS ACKNOWLEDGES THAT

# Todd Burgesser

HAS SUCCESSFULLY COMPLETED  
HAPSITE BASIC & ADVANCED OPERATOR TRAINING

A handwritten signature in blue ink, appearing to read "Dan Schenk".

---

DAN SCHENK, TRAINER

---

NOVEMBER 21, 2017

---

Appendix B  
Example Chain-of-Custody  
Documentation







---

Appendix C  
Laboratory Quality Assurance  
Manual







**EMAX  
QUALITY  
SYSTEMS  
MANUAL  
2019  
Rev. 5.3**

**EMAX-QS00**

This manual is considered confidential within EMAX. The Quality Systems Manual is available for use by laboratory personnel through the EMAX browser and by means of controlled distribution. The procedure for controlled distribution of this manual is detailed in EMAX-DM02, Controlled Documents. The manual must not be altered other than by a duly authorized representative of EMAX.

If the document has been provided to external users or regulators, it is for the exclusive purpose of reviewing EMAX quality systems. The external party or parties shall not use it in any other way without the prior written permission of an authorized representative of EMAX Laboratories, Inc.



1835 W. 205<sup>TH</sup> ST., TORRANCE, CA 90501  
310-618-8889 (TEL)  
310-618-0818 (FAX)  
[info@emaxlabs.com](mailto:info@emaxlabs.com) (email)  
[www.emaxlabs.com](http://www.emaxlabs.com) (web)

# QUALITY SYSTEMS MANUAL

EFFECTIVE DATE: SEPTEMBER 09, 2019

DOCUMENT ID: EMAX-QS00

REVISION 5.3

APPROVED BY:

A handwritten signature in green ink, appearing to read "Kenette Pimentel", written over a horizontal line.

**KENETTE PIMENTEL**  
QUALITY ASSURANCE & DATA VALIDATION MANAGER  
(SIGNATURE)

A handwritten signature in green ink, appearing to read "Ye Myint", written over a horizontal line.

**YE MYINT**  
TECHNICAL OPERATIONS MANAGER  
(SIGNATURE)

A handwritten signature in green ink, appearing to read "Caspar Pang", written over a horizontal line.

**CASPAR PANG**  
CHIEF EXECUTIVE OFFICER & LAB DIRECTOR  
(SIGNATURE)

## Preface

EMAX Quality Systems (EMAX-QS00) was designed to guide its Laboratory Operations and Data Validation to deliver data conformant to environmental industry standards.

EMAX Laboratories, Inc., (EMAX) has provided comprehensive environmental laboratory services to governmental, state and local agencies since 1987. EMAX was founded to fill a need within the California marketplace for a flexible, reliable, and cost-effective analytical laboratory for consulting firms involved in the early stages of site investigation and remediation. EMAX has also provided fundamental services for the development of statewide and regional environmental compliance, enforcement, and remedial action programs.

Similarly, EMAX had the opportunity to provide large-scale analytical support to the initial and then burgeoning environmental restoration programs of the branches of the Department of Defense, Department of Energy, and United States Environmental Protection Agency. EMAX occupies a state-of-the-art, 27,000 square foot physical plant in Torrance, California.

The industry EMAX supports has undergone periods of growth, uncertainty, and consolidation. EMAX however, has maintained levels of stability and consistency. With a strong dedication to the continuation of our technical proficiency, we place extreme emphasis on in-house training, third-party review of procedures and protocols, and the audit and peer-review processes.

Over the years, EMAX has distinguished itself within the laboratory services industry by its stability in staff, its recognized technical proficiency, and its commitment to providing analytical deliverables in a wide variety of either agency-specified or client-developed reporting formats. We must share a large portion of our success in these areas with our clients, for it is a product of their dedication, input, and communication with us.

EMAX, a Small Disadvantaged Business (SDB), has been evaluated and audited by numerous governmental agencies and private-sector clients, and has provided analytical services in support of the overall environmental programs of the

- ① United States Environmental Protection Agency
- ① United States Air Force, The Air Force Center for Environmental Excellence
- ① United States Army, Army Corps of Engineers
- ① United States Navy, and
- ① United States Department of Energy

Therefore, it is incumbent for EMAX to update this manual to conform with the requirements of The NELAC Institute (TNI), EL-V1-2011, Modules 1, 2 and 4 and the DoD Quality Systems Manual (DoD/DOE QSM) for Environmental Laboratories, Version 5.3, Modules 1, 2 and 4 and Appendices A, B and C.



## TABLE OF CONTENTS

---

### **VOLUME 1, MODULE 1, PROFICIENCY TESTING** \_\_\_\_\_ **8**

|   |           |
|---|-----------|
| <b>1.0 INTRODUCTION</b>                       | <b>9</b>  |
| <b>2.0 REQUIREMENTS FOR ACCREDITATION</b>     | <b>9</b>  |
| 2.1. INITIAL ACCREDITATION                    | 9         |
| 2.2. CONTINUING ACCREDITATION                 | 9         |
| <b>3.0 DOE REQUIREMENTS FOR PARTICIPATION</b> | <b>10</b> |
| 3.1. INITIAL INCLUSION                        | 10        |
| 3.2. CONTINUED PARTICIPATION                  | 11        |

### **VOLUME 1, MODULE 2, QUALITY SYSTEMS GENERAL REQUIREMENTS** \_\_\_\_\_ **12**

|   |           |
|---|-----------|
| <b>1.0 INTRODUCTION, SCOPE AND APPLICABILITY</b>  | <b>13</b> |
| <b>2.0 REFERENCES</b>   | <b>13</b> |
| <b>3.0 TERMS AND DEFINITIONS</b>  | <b>13</b> |
| <b>4.0 MANAGEMENT REQUIREMENTS</b>  | <b>13</b> |
| 4.1. ORGANIZATION   | 13        |
| 4.2. MANAGEMENT SYSTEMS   | 15        |
| 4.3. DOCUMENT CONTROL   | 21        |
| 4.4. REVIEW OF REQUESTS, TENDERS AND CONTRACTS  | 21        |
| 4.5. SUBCONTRACTING ENVIRONMENTAL TESTS   | 23        |
| 4.6. PURCHASING SERVICES AND SUPPLIES   | 23        |
| 4.7. SERVICE TO THE CUSTOMER  | 24        |
| 4.8. COMPLAINTS   | 24        |
| 4.9. CONTROL OF NON-CONFORMING ENVIRONMENTAL TESTING WORK                                 | 24        |
| 4.10. IMPROVEMENT   | 25        |
| 4.11. CORRECTIVE ACTION   | 25        |
| 4.12. PREVENTIVE ACTION   | 27        |
| 4.13. CONTROL OF RECORDS  | 27        |
| 4.14. INTERNAL AUDITS   | 28        |
| 4.15. MANAGEMENT REVIEW   | 29        |
| 4.16. DATA INTEGRITY INVESTIGATIONS   | 30        |
| <b>5.0 TECHNICAL REQUIREMENT</b>  | <b>30</b> |
| 5.1. GENERAL  | 31        |
| 5.2. PERSONNEL  | 31        |
| 5.3. ACCOMMODATION AND ENVIRONMENTAL CONDITIONS   | 32        |
| 5.4. ENVIRONMENTAL METHODS AND METHOD VALIDATION  | 33        |
| 5.5. EQUIPMENT  | 35        |
| 5.6. MEASUREMENT TRACEABILITY   | 37        |
| 5.7. COLLECTION OF SAMPLES  | 38        |
| 5.8. HANDLING SAMPLES AND TEST ITEMS  | 38        |
| 5.9. QUALITY ASSURANCE OF ENVIRONMENTAL TESTING   | 39        |
| 5.10. REPORTING THE RESULTS   | 39        |
| <b>6.0 HAZARDOUS AND RADIOACTIVE MATERIALS MANAGEMENT AND HEALTH AND SAFETY PRACTICES</b> | <b>42</b> |

## TABLE OF CONTENTS

---

### **VOLUME 1, MODULE 4, QUALITY SYSTEMS CHEMICAL TESTING \_\_\_\_\_ 43**

|            |   |           |
|------------|---|-----------|
| <b>1.0</b> | <b>CHEMICAL TESTING _____</b>           | <b>44</b> |
| 1.1.       | INTRODUCTION _____                      | 44        |
| 1.2.       | SCOPE _____                             | 44        |
| 1.3.       | TERMS AND DEFINITIONS _____             | 44        |
| 1.4.       | METHOD SELECTION _____                  | 44        |
| 1.5.       | METHOD VALIDATION _____                 | 44        |
| 1.6.       | DEMONSTRATION OF CAPABILITY (DOC) _____ | 46        |
| 1.7.       | TECHNICAL REQUIREMENTS _____            | 46        |

### **APPENDIX A REFERENCES**

### **APPENDIX B EMAX ORGANIZATION AND MANAGEMENT**

|                     |  |
|---------------------|--|
| <b>APPENDIX B-1</b> | <b>Management Structure</b>                  |
| <b>APPENDIX B-2</b> | <b>List of Standard Operating Procedures</b> |
| <b>APPENDIX B-3</b> | <b>List of Major Equipment</b>               |
| <b>APPENDIX B-4</b> | <b>Accreditations</b>                        |
| <b>APPENDIX B-5</b> | <b>Health &amp; Safety Practices</b>         |



**EMAX  
QUALITY  
SYSTEMS  
MANUAL  
2019  
Rev. 5.3**

**VOLUME 1, MODULE 1,  
PROFICENCY TESTING**



## PROFICIENCY TESTING

---

### 1.0 INTRODUCTION

EMAX shall participate in proficiency testing (PT) as required by TNI and DoD standards. Generally, PT standards shall be purchased from ISO 17043 accredited PT providers.

### 2.0 REQUIREMENTS FOR ACCREDITATION

#### 2.1. Initial Accreditation

##### 2.1.1. Initial Accreditation for DoD ELAP

EMAX shall successfully complete at least two PT samples for each analyte-matrix-method where PT samples are commercially available.

##### 2.1.2. PT Samples for Initial Accreditation

Primarily, EMAX shall obtain PT samples from PT providers that are accredited under International Organization for Standardization (ISO) 17043.

EMAX also participates in MAPEP PT studies. This PT participation can also be utilized for initial accreditation.

##### 2.1.3. PT samples for non-ISO 17043 Accredited PT Provider

In the absence of ISO 17043 certified PT providers, EMAX shall obtain permission from the Accrediting Body to use a PT from a non-ISO 17043 accredited PT Provider prior to analyzing the PT sample.

##### 2.1.4. PT Samples for Analyte-matrix-method not from a PT Provider

In the event that a particular analyte in a given method and/or matrix can not be obtained from any PT provider, EMAX shall inform the Accrediting Body in writing that no PT provider is available for that specific parameter. Other requirements to substantiate the PT requirements shall be duly fulfilled. EMAX shall continue to survey for its availability and shall participate with the PT study as expected.

##### 2.1.5. Analysis Date of PT Samples

EMAX shall provide required PT results that are performed within 12 months, completed at least 15 calendar days apart.

##### 2.1.6. PT Study Determination

For initial accreditation or additional analyte(s) desired to be added to an existing method-matrix accreditation, EMAX shall request from the PT provider to send PT reports directly to the Accrediting Body unless instructed otherwise.

##### 2.1.7. Processing PT Samples

EMAX shall treat PT samples as regular field samples. They shall be received, logged and stored the same way as field samples. PT samples shall be prepared/extracted/digested (whichever is applicable) and analyzed with QC samples, e.g., method blank, lab control sample, etc., per method requirement. PT sample results shall be qualitatively and quantitatively evaluated as prescribed by the method.

#### 2.2. Continuing Accreditation

##### 2.2.1. Maintaining Accreditation

EMAX shall participate in PT studies at least twice a year at approximately six months apart (or >4 to <8 months apart). Regularly, EMAX joins the following PT round robins:

- ① Water Supply
- ① Water Pollution
- ① Soil / Hazardous Waste

## PROFICIENCY TESTING

---

- ⊙ Air & Emissions
- ⊙ Alaska Underground Storage Tank
- ⊙ Arizona Hydrocarbons
- ⊙ DOE MAPEP

### 2.2.2. EMAX PT History

EMAX had been participating with the above listed PT programs for more than 25 years and has successfully maintained a high success rate (98-100%).

EMAX shall maintain its practice to review PT reports from the providers upon receipt. Non-conforming results shall be assessed in accordance to EMAX-QA08, Corrective Action SOP. Resolution to the finding(s) shall be dealt accordingly and where necessary, preventive measures shall be instituted. In the event that the PT sample itself is the suspect for non-conformance, the provider shall be duly informed to take part in the root-cause analysis. Findings, corrective action and lessons learned drawn from root-cause-analysis shall be logged in the Non-Conformance database. Where new policies or procedures are enforced to correct the anomaly, all relevant personnel shall be involved and actions taken shall be properly documented. Corrective action shall be implemented to assure that resolution to finding(s) are in effect.

EMAX shall demonstrate due diligence that at least two out of the most recent three PTs shall successfully pass the PT acceptance criteria. EMAX shall retain PT records for at least five years.

### 2.2.3. Failure to Meet Criteria

It is of EMAX's best interest to maintain high score in Performance Testing. However, it is understood that failure to meet PT criteria at the frequency required, the analyte-method-matrix parameter shall be removed from the scope of accreditation.

### 2.2.4. PT Samples Same as Regular Environmental Samples

EMAX shall analyze and evaluate PT samples in the same manner as regular environmental samples. EMAX shall employ the same quality control, sequence of preparation and analytical steps, and replicates used when analyzing samples.

## 3.0 DOE REQUIREMENTS FOR PARTICIPATION

### 3.1. Initial Inclusion

#### 3.1.1. Initial Inclusion to DOECAP Program

EMAX shall successfully complete at least 2 PT samples from MAPEP or an ISO 17043 accredited PT provider. The PT shall, at a minimum, include analyte-method-matrix applicable to reportable data under DOE contracts.

#### 3.1.2. PT Sample for Initial Inclusion

EMAX shall maintain its radiological materials license from the Nuclear Regulatory Commission to be able to participate in analyzing MAPEP PT samples. MAPEP PT samples shall be obtained for all analyte-method-matrix parameters where available. Otherwise, PT samples shall be obtained from ISO 17043 accredited PT providers.

#### 3.1.3. PT samples for non-ISO 17043 Accredited PT Provider

In the absence of ISO 17043 certified PT providers, EMAX shall obtain permission from the Accrediting Body to use a PT from a non-ISO 17043 accredited PT Provider prior to analyzing the PT sample.

#### 3.1.4. PT Samples for Analyte-matrix-method not from a PT Provider

## PROFICIENCY TESTING

---

In the event that a particular analyte in a given method and/or matrix cannot be obtained from any PT provider, EMAX shall inform the Accrediting Body in writing that no PT provider is available for that specific parameter. Other requirements to substantiate the PT requirements shall be duly fulfilled. EMAX shall continue to survey for its availability and shall participate with the PT study as expected.

### 3.1.5. Analysis Date of PT Samples

EMAX shall provide required PT results that are performed within 12 months, completed at least 7 calendar days apart. In the event that MAPEP PTs are utilized, two consecutive MAPEP PT series shall be provided.

### 3.1.6. PT Study Determination

For initial accreditation or additional analyte(s) desired to be added to an existing method-matrix accreditation, EMAX shall request from the PT provider to send PT reports directly to the Accrediting Body unless instructed otherwise.

### 3.1.7. Processing PT Samples

EMAX shall treat PT samples as regular field samples. They shall be received, logged and stored the same way as field samples. PT samples shall be prepared/extracted/digested (whichever is applicable) and analyzed with QC samples, e.g., method blank, lab control sample, etc., per method requirement. PT sample results shall be qualitatively and quantitatively evaluated as prescribed by the method.

## 3.2. Continued Participation

### 3.2.1. Maintaining Participation

EMAX shall maintain its participation with MAPEP and other PT programs to meet requirements of DOE contracts. PT results shall be made available to DOE upon request. EMAX shall demonstrate due diligence that at least two out of the most recent three PTs shall successfully pass the PT acceptance criteria.

### 3.2.2. EMAX PT History

EMAX shall demonstrate due diligence that at least two out of the most recent three PTs shall successfully pass the PT acceptance criteria for each analyte-matrix-method combination. EMAX shall retain PT records for at least five years.

### 3.2.3. Reporting Requirements to DOE Sites

Where applicable, EMAX shall provide PT results to current DOE projects, within 10 days of receipt of results from the PT provider.

### 3.2.4. Failure to Meet Criteria

Likewise, EMAX shall implement EMAX-QA08 for non-conforming PT results as described in Section 2.2.2. EMAX shall also perform corrective action for any unacceptable PT results. When two(2) out of three(3) PT samples results are unacceptable, it is understood that DOE contract holder may cease to send samples to EMAX until an acceptable remedial PT is completed.

### 3.2.5. PT Samples as Regular Environmental Samples

EMAX shall analyze and evaluate PT samples in the same manner as regular environmental samples. EMAX shall employ the same quality control, sequence of preparation and analytical steps, and replicates used when analyzing samples.



**VOLUME 1, MODULE 2,  
QUALITY SYSTEMS GENERAL  
REQUIREMENTS**

## QUALITY SYSTEMS GENERAL REQUIREMENTS

---

### 1.0 INTRODUCTION, SCOPE AND APPLICABILITY

EMAX-QS00 is developed to guide EMAX and its constituents to carry out its undertakings fairly, consistently and competently within the boundaries of environmental analytical discipline. It describes EMAX's overall management commitment to Quality Systems, standardization of analytical practices and continuous improvement from acquired knowledge and lessons learned. It is imperative to EMAX to have a clear vision on how requirements are achieved in consideration of the veracity of different specifications and data quality objectives from one project to another. Rest assured that compliance to this document validates competency, impartiality and consistency to any work contracted by EMAX.

This manual is based on TNI Standard, EL-V1- 2011(compliant to version 2009) and DoD/DOE QSM Version 5.3, 2019. It is designed parallel to the sections in the TNI Standard and the DoD/DOE QSM to ensure that all requirements are covered.

This document is applicable to all EMAX projects unless directed otherwise. Federal, State or Local regulations, as well as Project and/or Contract specific requirements shall supersede this document. It shall be available to clients, regulatory authorities and accrediting bodies whenever deemed necessary.

### 2.0 REFERENCES

TNI Standards, 2011 (compliant to version 2009)

DoD/DOE Quality Systems for Environmental Laboratories, Version 5.3, 2019

ISO/IEC 17025:2017 and ISO/IEC 17025:2005 General Requirements for the Competence of Testing and Calibration Laboratories

### 3.0 TERMS AND DEFINITIONS

Relative to majority of EMAX's projects and the applicability of terms and definitions within the environmental industry, EMAX has adopted the DoD/DOE QSM terms and definitions as published in its version 5.3, 2019.

### 4.0 MANAGEMENT REQUIREMENTS

#### 4.1. Organization

**4.1.1.** EMAX holds all appropriate certifications, validations, approvals and licenses from federal, state and local agencies that mandates provision of legally defensible data for a wide variety of projects, from groundwater monitoring to investigation and remediation on National Priority List sites. These certifications, validations, approvals, and licenses define and document the range of laboratory activities that take place at EMAX while maintaining conformity with this manual, relative to the Standards referenced in Section 2.

The quality systems is designed to naturally practice impartiality on all of its activities and EMAX organization is structured to foster fairness in all of their actions within EMAX and its constituents.

**4.1.2.** EMAX shall ensure that its staff members, instrumentations, and facilities that carry out its activities adequately satisfy requirements of the standards embodied for this manual. Conformity to project specific requirements (PSR) defines client satisfaction and commitment to impartiality. To secure this responsibility, EMAX quality systems integrates project management and operations in such a way that PSRs are in the hands of staff members performing the analytical process on real-time basis. Refer to EMAX-QA01 for details.

**4.1.3.** EMAX operates one permanent facility. In the event that an activity necessitates to be conducted outside its permanent facility, EMAX shall ensure that such activity is managed similarly as required by this manual.

This organization also operates to ensure that there are measures employed so that its activities are free from undue pressures, may it be commercial, financial or functions internal and/or external to EMAX that may impair impartiality.

## QUALITY SYSTEMS GENERAL REQUIREMENTS

---

**4.1.4.** EMAX is not a part of any organization. In the event that an opportunity will arise, EMAX shall ensure that key personnel involved in analytical testing and/or signatories to analytical results shall be clearly identified and probable conflicts of interest does not exist within EMAX and/or between EMAX and the associated organization.

Laboratory activities shall be conducted without bias. Test results shall not be influenced or be construed of being influenced by any of the following:

- business relationships between the laboratory and the client
- family or personal relationships between people in the laboratory who will be involved in laboratory activities and the client
- financial interests in a venture related to the test results.

**4.1.5.** EMAX shall -

- a) empower its key personnel to carry out their responsibilities to ensure that established policies and procedures are consistently put into practice, continuous improvement is exercised, and due diligence in detecting divergence from normative practice as well as implementing preventive measures is second nature.
- b) demonstrate that all of its employees are free from any undue internal or external pressures and/or influences that may adversely affect the quality of their work. This process is detailed in EMAX's Ethics Program (EMAX-QA10).
- c) ensure that its customers' confidential information and propriety rights are protected. Electronic data shall be properly stored and transmissions shall be carried out as contractually prescribed. This is detailed in EMAX Code of Ethics, Appendix 1 of EMAX-QA10.
- d) ensure that activities undertaken by EMAX or its representative outside its laboratory operations shall be conducted in a professional manner, where promotions of its capabilities are factual, impartial and unprejudiced, and shall exercise ethical values set forth in EMAX-QA10.
- e) maintain an organizational chart to exhibit its organization and management structure. Refer to APPENDIX B-1.3, Figure 1. Relationships between quality management, technical operations and support services are described in APPENDIX B-1.1.
- f) have defined responsibilities, authority and interrelationships of all personnel within the organization affecting quality of data produced. Refer to APPENDIX B-1.2.
- g) have adequate supervisors to oversee its processes, to include training, instrument calibrations, data production and review. Refer to APPENDIX B-1.3, Figure 2.
- h) have a Technical Operations Manager to oversee laboratory technical operations to make sure that necessities are sufficiently maintained, may it be personnel, services and/or supplies as well as technical knowhow in producing quality data.
- i) have a Quality Manager who reports directly to EMAX's President and is responsible to ensure that quality systems is implemented and observed continuously. In the absence of the QA Manager, the QA/QC Coordinator shall be acting on behalf of the QA Manager. Refer to APPENDIX B-1.3, Figure 1.
- j) ensure that the following key personnel are employed:
  - i. President & Laboratory Director
  - ii. Operations Manager
  - iii. Laboratory Supervisors
  - iv. Quality Assurance and Data Validation Manager
  - v. Project Managers

## QUALITY SYSTEMS GENERAL REQUIREMENTS

---

- vi. Information Systems Manager
  - vii. Business Manager
- 4.1.6.** EMAX shall mandate its technical staff to review this manual to ensure awareness, understanding and implementation of the objectives of the quality systems; their responsibilities and consequence of their actions in executing their activities.
- 4.1.7.** Appropriate communication processes are imbedded in EMAX's administrative SOPs (Quality Assurance, Quality Control, Data Management, and Information Systems). In addition, top management shall practice open-door policy to encourage honesty and transparency. Additional Requirements for QA and Operations Managers:
- 4.1.7.1. The QA manager or his/her designee shall -
- a) serve as the focal point of QA/QC and be responsible for the oversight and/or review of quality control data
  - b) have functions independent from laboratory operations QA/QC functions
  - c) be able to evaluate data objectively and perform assessments without outside influence
  - d) have documented training and/or experience in QA/QC procedures and laboratory quality systems
  - e) have general knowledge of analytical methods for which data review is performed
  - f) arrange for or conduct internal audits annually
  - g) notify laboratory management of deficiencies and the quality system
  - h) monitor corrective actions
  - i) implement, maintain, and improve the management system by using available tools such as audit and surveillance results, control charts, proficiency testing results, data analysis, corrective and preventive actions, customer feedback, and management reviews in efforts to monitor trends.
- 4.1.7.2. The Operations Manager or his/her designee shall -
- a) oversee day-to-day operations to include data generation, reporting and review;
  - b) have overall experience in the fields of accreditation for which EMAX has been accredited or where accreditation is being acquired;
  - c) have duties that shall include monitoring of quality control standards and validity of data produced;
  - d) be exclusive to EMAX and shall not serve any other laboratory bearing same function unless otherwise approved by the primary accrediting body.
  - e) assign a designee when absent for more than 15 consecutive calendar days and shall inform the primary accrediting body in writing when absent for more than 35 consecutive calendar days.
  - f) meet the qualifications described in Section 5.2.6.

### **4.2. Management Systems**

- 4.2.1.** EMAX shall function and maintain its operations through established standard operating procedures (SOP), systems in place and as guided by this manual. All personnel are trained, as appropriate, utilizing these documents. Such trainings are culminated by an acknowledgment that they have fully understood and attest to implement such. EMAX Browser was established to provide an easy access to these documents for laboratory personnel. All documents generated at EMAX shall be written in English.

## QUALITY SYSTEMS GENERAL REQUIREMENTS

---

All information pertaining data gathered and client information shall remain confidential unless otherwise instructed by the client.

**4.2.2.** The management team of EMAX is committed to assure that its quality system policies and objectives are habitually practiced and imbedded in its operations. Primarily, EMAX quality systems principles are based on:

- a) Commitment to serve its clients such that contract agreement and PSR are attentively employed.
- b) Assurance to maintain its standard practice of analytical testing where data collection and processing shall be precisely performed, accurately presented and scientifically valid.
- c) Quality Systems Objectives
  - To promote quality culture through leadership, quality management, and organizational learning;
  - To uphold data integrity by addressing ethical practices through employee training, and practicing impartiality among employees;
  - To provide a healthy work environment by maintaining a clean, well ventilated and lighted facility
  - To afford adequate equipment to produce reliable data.
  - To deliver client satisfaction by producing data of known quality on time.
  - To establish a continuous process of improvement through lessons learned, preventive measures, and quality control.
- d) Conformance to demonstration of personnel capability to perform environmental testing activities and adherence to established the policies and procedures affecting their work including proper documentation; and
- e) Commitment to comply with the adopted Standards. It is of EMAX best interest to practice continuous quality systems improvement as part of its commitment to service. This can be sustained by:
  - Meeting customer requirements;
  - Operating in accordance with statutory and regulatory requirements; and
  - Operating in accordance with the laboratory's documented ethics policy.
  -
- f) Commitment to confidentiality. In the event that EMAX is required by law or contractually obligated to release confidential information, the client shall be notified about the information to be released.

**4.2.3.** As evidence of its commitment to sustain the objectives of the quality systems, EMAX management team shall

- a) Ensure that processes needed for managing quality systems are established, maintained and implemented
- b) Conduct management review at least once a year. This process shall use operational metrics to gauge effectiveness of its systems, client satisfaction and fulfillment of contract obligations. This effort will also allow the management to discover and eliminate probable factors to cause quality issues, slow down deliveries and/or any existing concern affecting productivity as well as processes that do not have added values.
- c) Ensure availability of resources, may it be personnel, equipment, facility or supply needs.
- d) Safeguard information about the client obtained from other sources other than the client by keeping it confidential to the client unless otherwise agreed by the source.

4.2.3.1. In addition EMAX management shall



## QUALITY SYSTEMS GENERAL REQUIREMENTS

---

- a) Define minimum qualifications, experience and skills necessary for all positions in the laboratory. Refer to APPENDIX B-1.2, for details.
- b) Train all laboratory personnel to function as positioned. Refer to Training SOP (EMAX-QA05) for details Demonstration of Capability requirements.
- c) Keep laboratory personnel training records up-to-date as described in EMAX-QA05.
- d) Record laboratory and operational activities, as appropriate. Refer to laboratory logbooks for details.
- e) Adequately supervise all laboratory personnel. Refer to APPENDIX B-1.3, Figure 2 for details.
- f) Ensure that samples received are accepted, verified and logged in accordance to sample receiving SOP (EMAX-SM02).
- g) Record quality of all data reported. Refer to analytical logs for details.

**4.2.4.** Project management system shall be responsible to disseminate project and contractual requirements to respective personnel. To augment this function, operations and quality assurance meetings shall from time to time reiterate the importance of fulfilling PSRs and contractual obligations.

Business Managers, Project Managers, Project Coordinators or any other personnel acting on behalf of EMAX, shall keep all information gathered or created by EMAX's activities, confidential, unless as required by law.

**4.2.5.** EMAX Standard Operating Procedures (SOP) organized as follows :

- a) Analytical
- b) Sample Management
- c) Quality Assurance
- d) Data Management
- e) Information Systems

Approved versions of these SOPs are accessible by all laboratory personnel through EMAX Browser.

**4.2.6.** Roles and responsibilities of EMAX's technical management and QA manager are detailed in APPENDIX B-1.2. Additional responsibilities for QA and Operations managers are described in Section 4.1.7.1 and Section 4.1.7.2, respectively.

**4.2.7.** When changes are planned, EMAX management shall ensure that integrity of quality systems is not jeopardized. Such plans shall be carefully reviewed to make certain that contradictions and/or conflicts to other facets of quality systems do not exist. This process shall require review and approval from the QA Manager and Laboratory Director prior to implementation.

**4.2.8.** Data Integrity

**4.2.8.1.** EMAX ethics program details process of data integrity training, in-depth monitoring and documentation. Refer to EMAX-QA10 for details. This program shall include:

- a) Steps for confidential reporting of data integrity concerns
- b) Process of informing EMAX management in the event that there is an ethical concern and the need for further investigation is deemed necessary.
- c) Detection and deterrence of improper and unethical actions. This process shall include the following aspects:
  - i. Records that the ethics policy was read and signed by all employees
  - ii. Objective evidence that annual ethics training is observed

## QUALITY SYSTEMS GENERAL REQUIREMENTS

---

- iii. Analyst shall explain, sign and date when data was manually changed.
  - iv. Where available, data acquisition software's electronic tracking or audit trail functions shall be enabled
- 4.2.8.2. The quality assurance manager shall keep EMAX-QS00 current; shall review it annually and update it as necessary.
- 4.2.8.3. The quality manual structure shall be compliant to the standards referenced in this manual.
- a) The title manual is titled as "EMAX Quality Systems Manual" and its document ID shall be EMAX-QS00.
  - b) The laboratory name is EMAX Laboratories, Inc.( EMAX), located at 1835 W. 205<sup>th</sup> St., Torrance, CA 90501.
  - c) The primary person responsible for EMAX is Mr. Caspar Pang. He can be reached at 310-618-8889 or CPang@emaxlabs.com
  - d) EMAX laboratory organizational structure is illustrated at APPENDIX B-1.3, Figure 2.
  - e) EMAX approved signatories
    - 1) The President & Laboratory Director is the primary signatory for EMAX.
    - 2) In the absence of the Laboratory Director, the QA Manager and the Operations Manager assume the technical functions of the Laboratory Director. The assumption of this duty carries with it the responsibility to assure that all of their actions shall be in accordance, but not limited to EMAX approved policies and procedures, EMAX Quality Systems, EMAX Standard Operating Procedures, Project Specific Requirements, Project Contract Specifications, and other directives related to EMAX laboratory activities.
    - 3) Alternatively, the Project Managers, limited to the specific project(s) they handle, may also assume the technical functions of the Laboratory Director. Likewise, this duty carries with it the responsibility to assure that all of their actions shall be in accordance, but not limited to EMAX approved policies and procedures, EMAX Quality Systems, EMAX Standard Operating Procedures, Project Specific Requirements, Project Contract Specifications, and other directives related to EMAX laboratory activities.
    - 4) List of approved signatories is included in EMAX E-1.3, Figure 1.
  - f) Concurrence and signature page is in the first page of this document
  - g) Objectives of quality systems are in Section 4.2.2.c.
  - h) EMAX quality policy statement is in Section 4.2.2.
  - i) Table of contents, references and appendices is in page 5.
- 4.2.8.4. EMAX Quality Systems shall include the following:
- a) Maintenance, calibration and verification procedures for conducting tests, refer to EMAX SOPs.
  - b) Major equipment and reference measurement standards, facilities and services, refer to APPENDIX B-3, Equipment, Facilities and Services.
  - c) Verification practices, refer to Proficiency Tests.
  - d) Procedures for reporting analytical results, refer to Analytical SOPs.
  - e) Organization and management structure, refer to APPENDIX B-1.3, Figures 1 and 2.
  - f) Document control procedure, refer to EMAX-DM02.
  - g) Job description of key staff, refer to APPENDIX B-1.2.

## QUALITY SYSTEMS GENERAL REQUIREMENTS

---

- h) Procedures for achieving traceability of measurements are embedded in SOPs as a function of documentation of data acquired, may it be through instrument electronic data output or manually transcribed as observed.
- i) List of analytical SOPs, refer to APPENDIX B-2, List of EMAX SOPs.
- j) Procedure for reviewing new work, refer to EMAX-QA01, Project Management.
- k) Procedures for handling samples, refer to EMAX SOPs for Sample Management.
- l) Procedure for non-conforming events, refer to EMAX-QA08, Corrective Action.
- m) Procedures for departures from documented policies and procedures.

Departures from documented policies and procedures or from standard specifications should be saved, and if it is unavailable, the laboratory management will treat it on a case by case basis taking into consideration the impact of the quality of data.

Departures and deviations from SOP that are due to project DOQ/PRS are handled by the project management system. Other departures and deviations are classified as minor or major changes. When a departure and/or deviation from SOP will have no impact on data quality, the change is deemed to be a minor change requiring approval of either the immediate supervisor or the Technical Operations Manager.

Any departure and/or deviation from SOP that may affect the quality of data is deemed a major change and requires the approval of both the Technical Director and the QA Manager. When granting such approval, the Laboratory Director and the QA Manager shall consider whether the justifying circumstances are of such significance that an addendum to the SOP, a revision of the SOP or a new SOP is needed.

- n) Procedures for dealing with complaints

EMAX shall treat customer satisfaction with high priority. All customer complaints shall be considered and assessed appropriately. A Project Manager (PM) shall be designated as primary point of contact at the inception of the project and shall serve as the conduit between the customer and EMAX. The PM shall be responsible in resolving issues from the time sampling supplies are ordered to the time the data deliverables are delivered. The PM is also responsible for responding to future questions that may arise from submitted data, hard copy and/or electronic. EMAX-QA08 details the guidelines for taking care of customer complains.

- o) Procedures for protecting confidentiality and propriety rights

EMAX will not intentionally disclose to any person (other than the representative(s) designated by the client) services rendered or information received and/or generated by EMAX.

All employees, upon joining EMAX are informed of the importance of the policy on protecting confidentiality and EMAX'S propriety rights. All data received and generated at EMAX shall remain confidential within EMAX Laboratories, Inc. Reports and other pertinent information is only disclosed by authorized personnel to the clients concerned. No one is permitted to remove or make copies of any EMAX records, reports or documents without prior management approval. Disclosure of confidential information could lead to dismissal.

- p) Procedures for audits and data review, refer to EMAX-QA07 and EMAX-DM01.
- q) Procedures for personnel training and competency, refer to EMAX-QA05.
- r) Policy for the use of unique electronic signatures, where applicable.

Electronic data and/or electronic logbooks shall bear the identification of the analyst that performed the process. They shall be identified with first initial and the first 5 characters of the analyst's last name (e.g.

## QUALITY SYSTEMS GENERAL REQUIREMENTS

---

KPimen for Kenette Pimentel) or their last name should their last name be <6 characters (e.g. JDoe for John Doe). This identification is equivalent to electronic signature. The electronic signature shall be authenticated by the initials of the secondary data reviewer during data review.

- s) Procedure for procurement of standards, refer to EMAX-QC02 and EMAX-QA09.
- t) Data management procedures including validation, verification and purging of electronic data and data systems, refer to EMAX SOPs for Data Management.
- u) Procedures for manual entry of raw data from analytical measurements that are not interfaced to LIMS and the verification of records for accuracy of manually entered data, refer to EMAX-DM01 – Data Flow and Review.
- v) Procedures for making changes to electronic data, refer to EMAX-DM01 – Data Flow and Review.
- w) Procedures for electronic data processing, reporting and storage, refer to Analytical SOPs, section on Report Generation.
- x) Procedures for data review, for general data review procedures, refer to EMAX-DM01 – Data Flow and Review and for method specific data review procedures, refer to analytical SOPs.
- y) List of current certifications or accreditations, refer to APPENDIX B-4, List of Accreditation.
- z) Health and Safety, refer to APPENDIX B-5.
- aa) Material (Waste) Management, refer to APPENDIX B-5.

4.2.8.5. EMAX SOPs are categorized as follows:

- 1) Quality Assurances SOPs are established to manage and detail the execution to the overall quality assurance objectives and policies.
- 2) Supplemental Quality Control SOPs are established controls auxiliary to Analytical and Quality Assurance SOPs.
- 3) Sample Management SOPs are established policies and procedures for sample custody from cradle to grave.
- 4) Analytical SOPs are established tests manuals adopted from approved reference methods e.g., EPA Methods, Standard Methods, or other industry approved methods.
- 5) Data Management Procedures are established guidelines for data control from generation to archival.
- 6) Information Systems Procedures are guidelines to manage electronic media from software development to electronic data archival.
- 7) Radiation Safety SOPs are established policies and procedures for handling samples from DOE-sponsored projects or samples suspected to have limited quantity of radioactive material.

EMAX SOPs listed above are developed and maintained to reflect its current practice. These documents are:

- a) detailed to depict procedures that can be understood by a qualified personnel to execute the job;
- b) downloaded to the network (EMAX Browser) for employees' easy access;
- c) published bearing effective date and revision number and the signatures of the approving authorities;
- d) established as standalone procedures so they can be performed as written
- e) developed and maintained for all accredited analytes or method;
- f) internally developed detailing the steps to execute the requirements of the referenced method including any deviation from the published method, refer to APPENDIX B-2. Deviations from the referenced

## QUALITY SYSTEMS GENERAL REQUIREMENTS

---

method are detailed in the SOPs' supplementary notes section. EMAX SOP for Writing SOP (EMAX-QA00) for details of SOP structure;

- g) reviewed for accuracy and adequacy and updated as necessary. Technical SOPs are reviewed by competent personnel at least once a year to include Chemical Hygiene, Waste Management and Radiation Protection applicable to DOE sponsored projects.

### 4.3. Document Control

#### 4.3.1. General

EMAX established a standard operating procedure for writing SOP (EMAX-QA00) to standardize the process on generating, maintaining and controlling standard operating procedures. Document Control SOP (EMAX-DM02) is established to cover document identification, filing, distribution, control, changes, retention, protection, preservation, archival, retrieval, and disposal of controlled documents.

Document control policies and procedures related to or supplementary to analytical processes (e.g. calibration of support instruments) are imbedded in the analytical SOPs or in SOPs specific to the activity being performed.

#### 4.3.2. Document Approval and Issue

4.3.2.1. All documents in the laboratory as part of the quality system are reviewed and approved by the Laboratory Director and the QA & DV Manager prior to issue. EMAX Browser was established to provide an easy access to these documents for laboratory personnel. The browser table of contents is maintained to list the SOPs, its current version and the latest document review date. The QA & Data Validation Department controls the documents loaded in the browser so that only the most recent edition is available for use to preclude the use of invalid and/or obsolete documents. Other distributions are recorded on the document control ledger kept with the original SOP.

4.3.2.2. The controls for document approval and issue ensure that:

- a) only authorized editions are available for use and are accessible throughout the lab;
- b) SOPs are reviewed by both the user and the QA & DV Department to ensure that current practice is consistent with the approved procedures as well as the referenced methods;
- c) obsolete documents are removed and replaced upon approval and replacements are made available for access;
- d) obsolete documents are voided and archived for at least 5 years from the date it was voided;
- e) new editions, revisions and/or changes to SOPs are emailed to relevant supervisors for them to disseminate and mandate document review to significant staff members;
- f) document reviews shall be completed by accomplishing document review form (DRF);
- g) in the event that additional or special instruction is required to conform to PSR, such instructions are controlled by the project code.

### 4.4. Review of Requests, Tenders and Contracts

4.4.1. EMAX Project Management SOP (EMAX-QA01) describes the procedures for the review of requests, tenders and contracts. The policies and procedures of this SOP include:

- a) PSRs, including the methods to be used, quality control procedures, reporting formats, deliverables and other requirements to fulfill contract agreement.

## QUALITY SYSTEMS GENERAL REQUIREMENTS

---

- b) A process to ensure that the laboratory has the capability and resources to meet the PSR;
  - c) Appropriate selection of environmental test method to meet the PSR.
- 4.4.1.1. Where new methods are to be developed or additional analytes are required by a project, the Operations Manager is consulted purposely to review capability and readiness to deliver the environmental tests in query. The review process includes demonstration of capability, successful participation of proficiency testing (PT), detection limits, or other essential quality control requirements. The Project Manager (PM), where applicable, reviews current accreditation status of the laboratory and informs the client of the results of this review if it indicates any potential conflict, deficiency, lack of appropriate accreditation status, or inability on the laboratory's part to complete the client's work.
- 4.4.1.2. Conformity to a project specification shall be communicated to and agreed with the customer, unless inherently defined. EMAX shall also advise the client when the required test method is considered to be inappropriate or obsolete..
- 4.4.1.3. Any differences between the request or tender and the contract are resolved before any work commences. However, in instances where disparity, ambiguity or any other related circumstance arise thereafter, it shall be properly communicated and resolved. Contracts are generally drawn as written agreements to attest that the contract is acceptable to both parties. Where contract was agreed upon orally, they are followed by written statement (i.e., email or letter) confirming the agreement. Any deviations requested by the client shall only be considered if it does not affect the integrity of the EMAX or the validity of the results
- 4.4.2.** In summary, the PSR documents the PMs' review of the project requirements. These records shall be maintained by the PMs including agreed variances, pertinent discussions relating to client and/or project requirements. Records of PMs' completeness review of data produced during the execution of the contract shall be documented in the analytical record of each data package. Records of data package technical review shall be maintained with the data package retained at EMAX.
- 4.4.3.** Where part of the project is subcontracted, the PM is responsible for the review of contract requirement and make sure that the sub-tier lab is capable of providing the requirements of the project. Contingent upon the absence of sub-tier lab that is not qualified (e.g., no accreditation) to do the work but has the capacity to perform the work, the PM shall obtain consent from the client prior to using the sub-tier lab. Likewise, records of PMs' completeness review of shall include subcontracted work.
- 4.4.4.** In instances where deviation from the contract is dictated by a circumstance, the PM shall inform the client on a timely manner. Changes initiated by the PM are acknowledged by their dated initials. Where changes impact generation of deliverables (e.g., analyses, report forms, EDD formats, etc.), the PM is required to discuss the matter with the Laboratory Director and the Operations Manger.
- Waivers from QSM requirements are mostly executed during project proposal stage. Hence, such are already approved when contract is awarded. In the event that adherence to approved requirements become a challenge and/or not feasibly achievable during the project implementation stage, a waiver shall be requested in writing to the appropriate project contact person on a project-specific basis. It shall include technical justification relating to the specific project for the waiver. Documentation of approval for the waiver shall be maintained by EMAX Project Management and readily available for review.
- 4.4.5.** When change orders are initiated or if a contract needs to be amended after work has commenced, the PM shall go through the same review process and disseminate the amendments to all pertinent personnel. Likewise, when there are major changes at EMAX (e.g., suspension, revocation or withdrawal of accreditation, change of ownership, etc.), the PM is also responsible to inform the client.

## QUALITY SYSTEMS GENERAL REQUIREMENTS

---

### 4.5. Subcontracting Environmental Tests

- 4.5.1. Generally, subcontracted work decision to where the work is going is made by the client prior to contract award. When EMAX is tasked to select the subcontract lab, EMAX shall ensure that subcontracted laboratories meet the requirements of the project. This process is detailed in EMAX SOP for Subcontracting (EMAX-QA01).
- 4.5.2. EMAX shall obtain client consent upon qualifying a sub-tier lab before work is subcontracted, preferably in writing. In the event that oral approval was provided, the PM shall send a written statement (i.e., email, fax or letter) confirming the verbal approval.
- 4.5.3. EMAX is responsible to the client for the subcontractor's work, except in the case where the client or a regulatory authority specifies which subcontractor is to be used or when client consent was not obtained or granted.
- 4.5.4. A register of all subcontractors that EMAX uses for environmental tests and a record of the evidence of compliance are maintained by the designated PM.
- 4.5.5. In the event that EMAX is obligated to choose a sub tier lab, subcontracted labs shall at a minimum possess and maintain a NELAP accreditation in compliance to NELAP standards and meets all applicable requirements in performing the tests and capable of submitting results at the required format.
- 4.5.6. For DoD and/or DOE sponsored projects, the PM shall ensure that the subcontract lab meets the requirement of the latest version of DoD/DOE QSM prior awarding the subcontract.
- 4.5.7. Subcontracted labs shall possess and maintain DoD ELAP accreditation in compliance to DoD and/or DOE-sponsored projects.
- 4.5.8. For DoD and/or DOE-sponsored projects, unless otherwise subcontractor was selected by the client, the PM shall obtain project-specific approval from the DoD or DOE client before samples are analyzed.
- 4.5.9. In the event that the subcontracting lab has more than one facility, each participating facility shall go through the same qualification process as described in this manual.
- 4.5.10. Currently, all analyses performed at EMAX are completed from sample receiving to data package delivery (hardcopy and EDD). In the event that EMAX will have a need to outsource a segment of its management systems or outsource personnel, these services shall be subjected to abide by EMAX's management system and comply with the requirements of this manual. For DoD or DOE-sponsored projects, such services shall be subject for review and approval of the client.

### 4.6. Purchasing Services and Supplies

- 4.6.1. Procurement in general is under the supervision of the Operations Manager. Qualifying vendors and suppliers as well as purchasing are subject to the approval of the Operations Manager. Purchasing SOP (EMAX-QA09) describes EMAX's purchasing system, its policies, procedures and links to quality control of purchased materials, where applicable. This SOP is applicable for the procurement of laboratory instruments, analytical standards, reagents, chemicals, supplies, services and other related materials that the lab may need.  

Calibration services by third party shall be outsourced to an ISO/IEC 17025 accredited calibration laboratory.
- 4.6.2. Analytical Standards, solvents, reagents, chemicals or any other item that may affect the quality of environmental tests are not used until they have been verified to conform to requirements defined in the methods for the environmental tests concerned. Chemical QC SOP (EMAX-QC01) details the policies and procedures for acceptance/rejection of chemicals prior to its use. Records of actions taken to check compliance are endorsed, reviewed and maintained by the QA & Data Validation Department.

## QUALITY SYSTEMS GENERAL REQUIREMENTS

---

**4.6.3.** Approved purchased orders are utilized to place and receive orders. Materials are inspected upon receipt for accuracy. If received items concur with the packing slip and the purchase order, these documents are forwarded for payment approval. Otherwise, the Operations Manager is informed about any discrepancy.

**4.6.4.** The process of qualifying vendors and suppliers is detailed in EMAX-QA09. Documents generated during the process are maintained by the Operations Manager.

### **4.7. Service to the Customer**

**4.7.1.** The primary function of a PM is to serve as an interface between EMAX and the customer. A PM is designated for each project to review and clarify project requirements and monitor the laboratory's performance in relation to the work performed. While each PM may be serving more than one client, confidentiality to other clients is mandatory. This policy is also true and apparent to any constituent of EMAX anywhere they may be at any given time.

Each PM shall maintain and document communications with the client. The PM shall notify clients when the following are encountered:

- a) the client has specified incorrect, obsolete, or improper methods;
- b) methods require modification to obtain project data quality objectives (e.g., difficult matrix, poor-performing analyte);
- c) absence of PSRs (e.g., Quality Assurance Project Plan (QAPP), Statement of Work (SOW), Sampling and Analysis Plan (SAP), detection levels); or
- d) the laboratory has encountered problems with sampling or analysis that may impact results (e.g., improper preservation of sample holding time, turn-around-time).

**4.7.2.** Good project management shall foster and build strong working relationships with the clients. Hence, it is incumbent for PMs to make an effort to seek feedback from their clients. Both positive and negative feedback would help direct focus on management systems review and improve customer relations. This improvement process will not only sustain business health but will also show that EMAX genuinely cares about its customers' needs and opinion.

### **4.8. Complaints**

EMAX treats customer satisfaction with high priority. All customer complaints are entertained and assessed appropriately. The PM is responsible in making sure that issues are resolved from the time sampling supplies are ordered to the time the data deliverables are completed. The PM is also responsible for responding to future questions that may arise from submitted data, hard copy and/or electronic.

Corrective Action SOP (EMAX-QA08) includes policy and procedure for the resolution of complaints received from clients or other parties. Complaints are treated on a case-by-case basis. Lessons learned from these incidents are incorporated in the improvement process, where new policies may be implemented to prevent recurrence. Records of all complaints, investigations and corrective actions taken by the laboratory are maintained.

### **4.9. Control of Non-conforming Environmental Testing Work**

**4.9.1.** Quality control procedures are imbedded in every analytical SOP. These procedures also contain corrective actions for parameters that are nonconforming. This process shall ensure that:

- a) The Project Manager is informed by the Operations Manager of the nonconforming event with recommendation(s) on how to resolve the issue. Where data quality is affected, direction on how to



## QUALITY SYSTEMS GENERAL REQUIREMENTS

---

proceed is provided by the QA Manager. Where necessary (e.g., data quality is jeopardized), work shall be temporarily halted by the QA Manager until issue of concern is resolved.

- b) An evaluation of the significance of the nonconforming work is assessed.
- c) Corrective action is taken in a timely manner.
- d) Where data quality is or may be impacted, the PM notifies the client.
- e) When work is halted due to a non-conforming event, resumption of work is authorized by the QA Manager. In the absence of the QA Manager, the Laboratory Director may authorize resumption upon verifying that the non-conforming event is back to control.

**4.9.2.** Non-conforming events indicative of a need for further evaluation and/or measures to prevent recurrence is necessary, hence corrective action is initiated. This process is described in Section 4.11.

**4.9.3.** For DoD/DOE-sponsored projects, when corrective action is initiated due to potential data quality issue, the PM shall duly inform the client representative in accordance to the PSR. Records of corrective actions or proposed corrective actions to resolve the nonconformance shall be submitted to the client within 30 business days of discovery.

### **4.10. Improvement**

**4.10.1.** EMAX Quality systems management propels a continuous improvement cycle. It has to be effective, efficient, and equitable.

- a) Effectiveness is measured by how well its quality policy and objectives are portrayed by the data quality audit results and corrective and preventive measures.
- b) Efficiency is reflected by the receptiveness and ease in implementing established quality measures.
- c) Equitability is significant to maintain business existence. Identifying and discarding a non-value added activity and focusing on customer satisfaction is a key factor to equitable operation.

### **4.11. Corrective Action**

#### **4.11.1. General**

Policies and procedures established to resolve problems and restore proper functioning of laboratory operations when error, deficiencies or out-of-control situations arise are detailed in SOP for Corrective Action (EMAX-QA08).

#### **4.11.2. Cause Analysis**

Cause analysis is a fact-finding process purposely to identify the contributory factors that led to the non-conforming event. It shall include the timing, location and degree of the consequences caused by the nature of the incident. This should be carried out systematically and is best accomplished by team effort, openness and good documentation. Essential parts of cause analysis are:

- a) Defining the non-conforming event – what happened
- b) Collection of data – objective evidence, interviews, when did it happen
- c) Identifying possible causes – sequence of events leading to the problem, conditions allowing the problem to occur, other factors contributory to the problem. Was it systems, human or organization failure?
- d) Identify impact on data quality – identify associated data and determine if data quality is jeopardized.
- e) Identify lessons learned

#### **4.11.3. Selection and Implementation of Corrective Actions**

## QUALITY SYSTEMS GENERAL REQUIREMENTS

---

Meaningful cause analysis will draw significant considerations in configuring essential corrective action. Such consideration shall not only correct the problem but also prevent recurrence and occurrence of foreseen circumstances due to lessons learned from the nonconforming event.

Corrective action implementation shall be applied relative to all activities affected by the problem as well as possible sections where it could happen.

Documentation of non-conforming events is logged in the Non-Conformance Report (NCR) database.

### 4.11.4. Monitoring of Corrective Actions

The Operations Manager is responsible for monitoring the implementation and effectiveness of the corrective action. The QA Manager shall review the NCR database quarterly to determine appropriateness of corrective action taken and/or probable trends or recurrence. In the event that the corrective action implemented is unsuccessful, the Operations Manager and the QA Manager shall revisit the issues of concern and find measures to resolve the issue.

### 4.11.5. Additional Audits

When alleged breach of established policies and procedures or non-compliance with this manual is observed, the QA Manager or his/her designee, shall conduct an audit on appropriate areas of activity in accordance with Section 4.14 of this manual as soon as possible.

### 4.11.6. Documenting Corrective Action

Analytical Quality Control Procedure (QCP) is incorporated in every work order. The QCP includes corrective action for quality control parameters. In the event that other anomalies occur or corrective action in the QCP does not resolve the problem, the Supervisor is informed and a non-conformance report is initiated. Refer to Corrective Action SOP (EMAX-QA08).

### 4.11.7. Systematic Errors

Systematic error is bound to happen because it is inherent to the system. Therefore this type of error must be identified during cause analysis and corrective action shall necessitate change in the associated system to correct the problem.

### 4.11.8. Nonconformance Record Tracking System

EMAX has developed a NCR database where nonconformance events and corrective actions are logged. This process is an integral part of EMAX-QA08 and it includes:

- 1) Event description; corrective action recommendation (CAR) corrective action taken (CAT). The event description is initiated by the person that discovered the non-conforming event and informs the Supervisor or the responsible person for initiating CAR (e.g., the PM, if it requires client notification, the QA if it concerns data quality, PT). The CAR is initiated by the Supervisor or the responsible party. The CAT is initiated by the person responsible for implementing the CAR.
- 2) The Supervisor is responsible in making sure that actions are taken in a timely manner as well as the acceptability of course of action. Where data quality is or may be jeopardized, the PM is informed so that the client is notified.
- 3) These non-conformances and actions taken are logged in a database maintained by the QA & Data Validation Department.

The QA Manager or his/her designee performs a periodic review to check for appropriateness of the CAT, trending analyses or recurring problems. Where the QA Manager observes unsuitable CAT, trending or recurring events, the issue is brought to the Operations Manager and when necessary, involve the Laboratory Director for verification, evaluation and discussion of probable cure to the existing concern.

EMAX shall obtain approval from DoD ELAP Accreditation Bodies or the DOECAP Operations Team when changes to approved corrective actions implemented to address findings from a DoD or DOECAP assessment, as appropriate. Failure to obtain such approval in a timely manner may result in discontinued work until verification is completed.

## QUALITY SYSTEMS GENERAL REQUIREMENTS

---

### 4.12. Preventive Action

**4.12.1.** EMAX has established pro-active processes where identified potential sources of non-conformances or probable cause of problems may occur.

**4.12.2.** These processes include but not limited to the following:

- 1) Standard Operating Procedures are established so that proper course of action is followed across the board.
- 2) Chemicals used are passed through quality control prior to its use to prevent accidental use of underrated or adulterated chemicals.
- 3) Operations capacity is verified prior to accepting work and turning down work when project specifications are not within EMAX capability.
- 4) Appropriate personnel training and adequacy of commissioned equipment.
- 5) Continuous quality systems improvement obtained from technical experience, customer satisfaction, participation of performance testing, trend analysis (LCS, NCR and PT) and assessments (internal and external).

### 4.13. Control of Records

#### 4.13.1. General

Document Control SOP (EMAX-DM02) describes the policies and procedures of document management. This covers document identification, distribution, control, changes, retention, protection, preservation, archival and disposal of controlled documents.

All records are expected to be legible. They are stored and retained in such a way that they are readily retrievable in a suitable environment to prevent damage or deterioration and to prevent loss. These records are retained for a minimum period of five years.

Only authorized personnel can access the records warehouse.

Access controls to electronic records are established for LIMS and administrative files. All users of Company data must be authorized to access the appropriate systems and their resources. Access is controlled and monitored in accordance with Company policy. Copies of data, regardless of location, have the same data security and access control requirements as operational data. The elements involved in controlling and monitoring this access include identification, authentication, and authorization. Access levels are determined by the user's or user group's data access privileges. Access is granted by means of a computer account, which serves as identification. A computer account is created based on an approved request for network account.

Backing Up Files SOP (EMAX-IS09) describes policies and procedures of backing up files from a server, fixed disk or removable disk to a backup medium. All critical LIMS and administrative data are backed up on a regular basis. Files stored in servers are backed up daily. Workstation data are backed up at a frequency established by the user who generates the data. This frequency is influenced by the rate of generation of new data, the rate with which the data changes and the effort required to recreate information, if it is lost. Backup and archival methods shall be defined for all data files. Backup data shall be used to recover data when files have been destroyed. Archived data shall be kept for future reference. Retention times shall be defined for archived data. Provisions shall be made for off-site storage of daily and archival back ups.

#### 4.13.2. Technical Records

Technical records shall include all data collected to generate sample results, associated QC samples, calibrations and detection limits. These records shall include but not limited to internal chain of custody, raw data, instruments IDs and initials of staff members who participated in the analytical process (sample preparation, analysis and data review).

## QUALITY SYSTEMS GENERAL REQUIREMENTS

---

Data collection shall be traceable to the staff member that performed the task.

Transcription error correction is detailed in EMAX-QA08, Section 4.1, where corrected record should remain readable and the correction entered is initialed and dated. All original electronic records shall be retained. When corrections are due to reasons other than transcription errors (e.g. manual integration), the reasons for the correction are documented.

### 4.13.3. Additional Requirements

Cradle-to-grave documentation system is applied to every sample received at EMAX. These records shall:

- a) Include all information pertinent laboratory activities conceived to allow historical reconstruction of data deliverables. Laboratory logbooks or forms related to the laboratory activities are integrated with the specific SOP. Internal chain of custody logbooks record the history of inter-laboratory transfers of samples and/or extracts.
- b) Be retained for at least five years.
- c) Be available to the accreditation body.
- d) Be retrievable when records are stored only on electronic media.
- e) Have access logs, where applicable, to archived records.
- f) Have information necessary for the historical reconstruction of data. These records shall include:
  - i. all raw data for samples (lab QC and field), calibrations, logbooks
  - ii. related SOPs
  - iii. lab sample identification
  - iv. relevant dates – collection, lab receipt, preparation, analysis, calibrations, detection limit study/verification
  - v. relevant time – collection, lab receipt, preparation, analysis, calibrations, detection limit study/verification
  - vi. instrument identifications, maintenance logs, reference to operating conditions
  - vii. all manual calculations
  - viii. relevant analysts/operators – initials/signatures or electronic identification
  - ix. sample preparation information – sample amount, final volume, cleanup, SOPs, date, time, instrument IDs, standards/reagents, notations, etc.
  - x. test results
  - xi. standards and reagents information – standard/reagents logs, source/vendors, receipt, preparations,
  - xii. calibration criteria, frequency and acceptance
  - xiii. data and statistical calculations, review, confirmation, interpretation, assessment and reporting conventions
  - xiv. quality control protocols and assessment
  - xv. electronic data security, software documentation and verification, software and hardware audits, backups, and records of any changes to automated data entries
  - xvi. method performance criteria including expected quality control requirements
  - xvii. proficiency test results
  - xviii. records of demonstration of capability for each analyst
  - xix. records of names, initials and signatures for all individuals who are responsible for signing or initialing laboratory record
- g) All manual data entry shall be recorded legibly in permanent ink.
  - i. individuals rectifying an incorrect entry previously made shall date and initial the correction made;
  - ii. Corrections, other than transcription errors shall include reason for the correction.
- h) In the event that EMAX transfers ownership or goes out of business, unless there is pre-existing data transfer instructions, its clients shall be duly informed with a request of records transfer instructions. All records shall be transferred according to the client's instructions. In case of bankruptcy, appropriate regulatory and state legal requirements concerning laboratory records shall be followed.

### 4.14. Internal Audits

## QUALITY SYSTEMS GENERAL REQUIREMENTS

---

- 4.14.1.** Internal audits include both technical and systems audits. Technical audits verify compliance with method-specific requirements as well as operations related to the analytical process, data reduction, and data review. The process includes all actions related to data generation and the assurance of its quality. Systems audits verify compliance with the laboratory's quality systems, based on Standards governing this manual and applicable regulatory requirement to accomplish existing projects. Part of the systems audit would be a review of the policies and procedures for Quality Assurance, Quality Control, Sample Management, Data Management, Project Management, and Information Systems.
- 4.14.2.** Internal Assessment SOP (EMAX-QA07) describes the policies and procedures to carry out internal systems audit (ISA). The QA Manager shall plan and organize audits at a predetermined schedule. Such audits shall be carried out by the QA Manager or qualified personnel who are, wherever resources permit, independent of the activity to be audited.
- 4.14.3.** The audit schedule shall ensure that all areas of the laboratory are reviewed over the course of one year. Audit personnel shall be trained and qualified in the specific quality system element or technical area under review. Updated checklists shall be secured preferably from accrediting bodies (ABs) and shall be utilized to assure completeness.
- 4.14.4.** Immediate corrective action is required when critical findings where the correctness or validity of calibrations or test results is observed. Clients shall be duly informed in writing, as necessary.
- 4.14.5.** ISA report shall include 1) the area of activity audited, 2) the audit findings, and 3) corrective actions that arise from them. Refer to EMAX-QA07 for procedures in documenting internal audit. The Operations Manager and the Laboratory Director receive a copy of the Internal Assessment Report. The Operations Manager is responsible that the corrective actions are discharged within the agreed time frame as indicated in the report. Time frame for corrective actions is based on the magnitude of the finding and its impact on the defensibility and use of data.
- 4.14.6.** It is the responsibility of the QA Manager to follow-up, verify, and record the implementation and effectiveness of the corrective action taken. Where resolution or timeliness of the implementation of corrective actions is in question, the Operations Manager must inform the QA Manager and the Laboratory Director for re-evaluation and/or redirection.
- 4.14.7.** In the event that clients need to be informed about a finding,
- it is of EMAX's best interest to carry it out as soon as the information verification is completed;
  - corrective action target completion date shall be concurred with the client;
- 4.14.8.** Internal assessment shall be conducted with full cooperation of laboratory operations. Auditing team shall have full and free access to work areas, documents, instrumentations, laboratory personnel and all activities affecting quality.

### **4.15. Management Review**

- 4.15.1.** Members of the executive management submit their annual report to the QA Manager. The QA Manager consolidates the reports and draws an executive summary of annual management review. The management annual review is submitted to the Laboratory Director of the company for review. The Laboratory Director or a designee arranges an executive meeting to review the laboratory's quality system and environmental testing activities, their continuing suitability and effectiveness, and to introduce necessary changes or improvements. The review shall take account of:
- the suitability of policies and procedures;
  - reports from managerial and supervisory personnel;

## QUALITY SYSTEMS GENERAL REQUIREMENTS

---

- the outcome of recent internal audits;
- corrective and preventive actions;
- assessments by external bodies;
- the results of inter-laboratory comparisons or proficiency tests;
- changes in the volume and type of the work;
- client feedback;
- complaints; and
- other relevant factors, such as quality control activities, resources, and staff training.

**4.15.2.** Findings from management reviews and the actions that arise from them are included in the report. The Laboratory Director presides the executive meeting and directs course of action where changes are necessary.

The Operations Manager is responsible to ensure that identified action items concerning operations (e.g., initiate hiring or reshuffling and/or training of personnel, purchase or repair of equipment, facility improvement or maintenance, and other action items related to operations) are carried out within an appropriate and agreed timescale.

The QA Manager is responsible to ensure that identified action items concerning quality systems (e.g., policies and procedures, quality controls, and other action items related to quality systems improvement) are carried out within an appropriate and agreed timescale.

### **4.16. Data Integrity Investigations**

Ethics Program SOP (EMAX-QA10) details the process of promoting ethical values in the workplace, prevention of potential conflicts of interest, consequences of wrongful use of resources, mismanagement of contract agreements and proper conduct when dealing with ethical dilemma.

Discovery of potential issues shall be handled in a confidential manner and must be kept at a low profile while conducting evaluation, full investigation, or other appropriate actions needed to complete the process and have issues clarified.

All investigations that result in finding of inappropriate activity related to data integrity shall be documented and shall include any disciplinary actions involved, corrective actions taken, and all appropriate notifications of clients. All documentation of these investigation and actions taken shall be maintained for at least five years.

Any occurrence of inappropriate and/or prohibited laboratory practices shall be reported to the DoD ELAP Accreditation Body (AB) within 15 business days of discovery. These include findings of such inappropriate practices by laboratory staff and/or customer stakeholders. EMAX shall fully execute its zero tolerance policy regarding breach of ethical conduct. Records of associated corrections taken and proposed corrective actions to prevent recurrence shall be submitted to the AB within 30 business days of discovery.

EMAX shall also fully cooperate with its AB and the Environmental Data Quality Workgroup (EDQW) accordingly and shall treat these infractions seriously.

## **5.0 TECHNICAL REQUIREMENT**

## QUALITY SYSTEMS GENERAL REQUIREMENTS

---

### 5.1. General

#### 5.1.1. Factors affecting correctness and reliability of environmental test results:

- human factors (5.2);
- accommodation and environmental conditions (5.3);
- environmental test methods and method validation (5.4);
- equipment (5.5);
- measurement traceability (5.6);
- sampling (5.7); and
- handling of samples (5.8).

**5.1.2.** All measurements are subject to uncertainty. Total uncertainty of measurements is relative to the consistency or variability of how measurements are conducted. EMAX established environmental test methods and procedures, standardized training, and qualification of personnel, in conjunction to daily equipment check and procurement of service contracts for major equipment. EMAX designed its facility considering factors that may effect stability of equipment, minimize probable sources of contamination, health and safety of its workers, and ease for maintaining tidiness and cleanliness.

### 5.2. Personnel

**5.2.1.** EMAX technical staff undergoes training regardless of educational attainment and/or experience. Training is initiated with SOP reading, applicable quality controls and discussion of primary duties and responsibilities. With adequate supervision, the on-the-job training follows. The trainee will then have a chance to practice and build experience in the real work scenario applying all the necessary steps and quality controls that is required to complete the job. Training is culminated by the trainee's demonstration of capability.

**5.2.2.** Training SOP (EMAX-QA05) details the general process of conducting training. The Supervisor is tasked to conduct the training or assigns a mentor. The mentor identifies the SOPs needed for the training as well as all the necessary training needs to successfully execute and complete the training including a schedule/list of activities that needs to be completed. The progress of training is dependent on the background and skills of the trainee. The mentor shall document the training activities and shall determine when the trainee is ready for the job.

**5.2.3.** Currently, all laboratory personnel are employed by EMAX. In the event that there will be a need for additional technical and/or key support personnel, they shall undergo the same training, supervision and qualification process as the regular EMAX employees and must work in accordance with the EMAX's quality systems as well as health and safety practices.

**5.2.4.** Laboratory personnel training files are maintained and updated periodically by the QA & Data Validation Department. These records include:

- EMAX Resume to include their educational background, experience and current job description
- In-house training records
- Demonstration of Capabilities
- External Training (if any)

Minimum job descriptions are detailed in APPENDIX B-1.

**5.2.5.** Training records are forwarded to the QA & Data Validation Department for evaluation and certification to authorize specific personnel to perform particular types of environmental testing. The certification qualifies them to

## QUALITY SYSTEMS GENERAL REQUIREMENTS

---

conduct the first level of review on test results, give opinions and interpretations to test results, and to operate equipment specific to the test performed. The certification is approved by the Operations Manager and the QA & DV Manager.

### 5.2.6. Additional Personnel Requirements

Technical Directors employed shall possess the qualifications prescribed at TNI Section 5.2.6, as applicable.

### 5.2.7. Data Integrity Training

Every new employee goes through data integrity training and is renewed on an annual basis thereafter together with the current employees. Ethics Program SOP (EMAX-QA10) details EMAX business ethics, its policies and procedures, code of ethics, prohibited practices and how and when to report data integrity including its documentation process. Employees are required to have full understanding of their obligations and commitments related to data integrity. They, too, are made to be aware of that any infractions of the laboratory data integrity procedures will result in a detailed investigation that could lead to disciplinary action including immediate termination or be brought in the court of law. Data integrity trainings are authenticated by the participant's dated signature.

## 5.3. Accommodation and Environmental Conditions

### 5.3.1. Facilities

Significance of every facet of the laboratory was taken into consideration when EMAX designed its facilities. Its energy sources, lighting, and environmental conditions are planned and constructed to facilitate expected output of environmental tests.

To ensure that environmental conditions do not jeopardize the required quality of any measurement, controls are established and monitored. Fume hoods are adequately provided so that particular care when sub-sampling and environmental testing are undertaken. Technical requirements for accommodation and environmental conditions that can affect the results of environmental tests are monitored and documented.

### 5.3.2. Monitoring

All environmental conditions that require control are monitored and documented in accordance with the relevant specifications, methods and procedures or where they influence the quality of the results. Due attention are paid as appropriate to the technical activities concerned (e.g. Leaching requires controlled temperature, DOE lab requires frisking, etc.). Environmental tests shall be stopped when the environmental conditions jeopardize the results of the environmental tests.

In instances where monitoring or controls of any of the above-mentioned items are specified in a test method or by regulation, a course of action is included in the SOP relevant to the activity being performed to meet and document adherence to the laboratory facility requirements.

### 5.3.3. Cross-contamination Prevention

The laboratories were constructed to have effective separation between neighboring areas in which there are incompatible activities. Volatiles Laboratory is located farthest from the extraction lab and has independent mechanical controls; laboratories for DOE samples are isolated with independent mechanical controls and restricted entries.

All foreseen measures are taken to prevent cross-contamination. Sample storage for Volatiles is located in the Volatiles Laboratory. Samples from DOE sights that are identified as restricted samples are stored in the DOE Laboratory.

EMAX-QC08 SOP provides procedure for handling/isolating highly contaminated samples. Samples or extracts designated for volatile organics analysis are segregated from other samples and extracts. Samples suspected of containing high concentrations of volatile organics shall be further isolated from other volatile organics samples.



## QUALITY SYSTEMS GENERAL REQUIREMENTS

---

Storage blanks are used to determine if cross-contamination may have occurred. EMAX-QC03 describes the procedure and criteria for evaluating storage blanks, appropriate to the types of samples being stored.

### 5.3.4. Access Control

Specific areas in the laboratory can have limited access. Access is controlled but not limited to:

- Sample control room – where samples can only be accessed in the presence of a sample custodian or designee
- Warehouse – where sampling supplies, reagents, etc. are stored
- Analytical labs – are accessed by authorized analysts only during off hours
- Guests – requires escorting

### 5.3.5. Housekeeping

Good housekeeping promotes safe and environmentally friendly work area. It is an integral part of EMAX's Health and Safety program. Laboratory staff are trained to systematically organize and clean their work area every after use. This routine does not only prevent cross-contamination but also exemplifies respect to co-workers.

The Supervisors are responsible to make sure that their work areas are properly maintained and the Safety Officer conducts periodic inspection to ensure that the practice is sustained.

## 5.4. Environmental Methods and Method Validation

### 5.4.1. General

All analytical methods within EMAX's scope of accreditation are adaptations from published reference methods (e.g., USEPA Methods, Standards Methods for the Examination of Water and Wastewater, etc.). These SOPs provide details of the analytical process from sample storage to data reporting. Essential quality control procedures, deviation from the reference method and handling PSRs are also included in each of these SOPs. These SOPs are also updated as necessary.

### 5.4.2. Selection of Methods

Project Management SOP (EMAX-QA01) describes how methods for environmental testing, including methods for sample preparation, are dispensed to meet the needs of the client and which are appropriate for the environmental tests it undertakes.

Project method requirement shall include target analytes identified by the client on a project-specific basis. If project-specific information is not available, EMAX standard target analyte list shall be used.

If client did not specify the method or the method requested is obsolete, the PM shall suggest an appropriate method to the client. If the client concurs or has a different method preference, the client's preferred method shall be applied.

Where a project requires a method and/or analyte that is not within EMAX's scope of accreditation, EMAX shall make an effort to obtain accreditation. However, if accreditation is not feasible or the process is not completed prior to project commencement, EMAX shall inform the client about the accreditation status. Where client chooses to proceed with the analysis, EMAX shall identify those method(s) and/or analyte(s) in its report and their current accreditation status.

### 5.4.3. Laboratory Developed Methods

Method Development SOP (EMAX-QA03) details the process of method development for new methods and/or existing methods where new technology or a different technique can be applied to improve the method.

Hypothesis shall be drawn based on similar concepts from developed methods and shall be adjusted accordingly as the method development progresses. Process documentation is imperative in method development for proper course of action and generation of SOP. Method development shall be concluded with method proficiency. Method proficiency shall include detection limit study, demonstration of capability, bias and precision studies and successful analysis of PT sample (when available).

## QUALITY SYSTEMS GENERAL REQUIREMENTS

---

### 5.4.4. Non-Standard Methods (Not Applicable)

### 5.4.5. Validation of Methods (Not Applicable)

### 5.4.6. Estimation of Uncertainty

Factors affecting measurement uncertainty is estimated based on the complexity of the process. Note that the analytical process is only a fraction of the total measurement uncertainty for a target analyte. Hence, EMAX can not make measurement uncertainty corrections on sample results.

In the event that a project will require uncertainty of measurement to be applied to sample results, EMAX shall secure guidance for estimating measurement uncertainty from the client to prevent misinterpretation of results.

In the absence of guidance measurement uncertainty shall:

- a) Base its estimation of measurement uncertainty on laboratory control samples (LCS). LCSs are subjected to all possible sources of measurement uncertainty (e.g., sample sub-sampling, sample preparation, sensitivity of instrumentation, instrument calibrations, qualitative and quantitative evaluation). Hence, reasonable estimation of measurement uncertainty is revealed by the statistical evaluation of the LCS results at 99% confidence level.
- b) Method specific measurement uncertainties as published.
- c) Shall only apply measurement uncertainties when the project requires and the client concurs with EMAX's estimation of measurement uncertainty.

### 5.4.7. Control of Data

5.4.7.1. Data evaluation and review process are detailed in every analytical SOP. In addition, Data flow and Review SOP (EMAX-DM01) describes the general process of data generation and review. These SOPs include policies and procedures for:

- a) checking transcription and calculation errors
- b) data review against quality control procedures
- c) counterchecking manual calculations
- d) proper manual integration and its documentation

5.4.7.2. Where EMAX uses automated data acquisition, processing, recording, reporting, storage or retrieval of test data or calibration data, EMAX has established the following:

- a) Documentation and validation of software developed in-house are detailed in the following SOPs:
  - Software Documentation (EMAX-IS01)
  - Software Testing and Quality Assurance (EMAX-IS03)
- b) Data Security SOP (EMAX-IS08) details the policies and procedures for protecting laboratory programs and electronic data. Furthermore, EMAX has developed Ethics Program (EMAX-QA10) to uphold integrity and confidentiality of data entry or collection, data storage, data transmission and data processing.
- c) Hardware Maintenance SOP (EMAX-IS12) details computers attached to automated equipment are maintained to ensure proper functioning and are provided with the environmental and operating conditions necessary to maintain the integrity of environmental test data.

Commercial off-the-shelf software (e.g. word processing, database and statistical programs) in general use within their designed application range is considered to be sufficiently validated. However, laboratory software configuration or modifications must be validated as in 5.4.7.2a.

- d) Access controls, backup and archival, and routine disaster recovery are established and maintained by the Network Administrator to maintain security of data. Network users are issued passwords by the

## QUALITY SYSTEMS GENERAL REQUIREMENTS

---

Network Administrator. EMAX network is limited access. Only authorized personnel can amend computer records as permitted by their passwords.

- e) The Network Administrator shall conduct initial computer security awareness training prior to issuance of a password. A refresher course shall be conducted on an annual basis by the Network Administrator.
- f) Internal assessment shall include inspection of electronic data management. At a minimum, a check if the backup and recovery process is exercised at a frequency specified in EMAX-IS09.
- g) The PM shall inform the client about any changes that may affect electronic deliverables and its associated data (raw data, calibration data, processed reports, etc.).
- h) Spreadsheets that are used for laboratory templates are read-only and protected to prevent accidental or intentional eradication or deletion of embedded formulas and macros. Spreadsheet verification is accomplished prior to release for use. Documentation of verifications is maintained by the QA and DV Department.
- i) For computer software developed in-house, policies and procedures are detailed in the following SOPs:
  - Software Documentation (EMAX-IS01)
  - Software Development Methodologies (EMAX-IS02)
  - Software Testing and Quality Assurance (EMAX-IS03)
  - Software Maintenance (EMAX-IS04)
- j) Record to demonstrate the validity of laboratory generated software are stored in EMAX Network.
- k) Electronic Data Security measures are detailed in EMAX-IS08.

### 5.5. Equipment

- 5.5.1. EMAX major Instruments are listed in APPENDIX B-3. In addition, all support instruments to support quality control and analytical processes are adequately provided for the laboratory. These instruments are obtained and maintained as required by the Standards governing this manual.
- 5.5.2. Instrument (and its software, as applicable) calibration capability is always a deciding factor in considering instrument acquisition. Both qualitative and quantitative sensitivity and accuracy are carefully looked at prior to purchase. Operations have to meet sensitivity and all calibration requirements before an instrument is put to use.
- 5.5.3. Proper use of equipment is a significant part of training. It includes daily and periodic instrument care and detecting apparent instrument breakdown and troubleshooting when doable in-house. Analysts shall complete demonstration of capability prior to operating any equipment on their own.
- 5.5.4. Each instrument is uniquely identified and is traceable to the data it generates. Data acquisition software (where applicable) is identified in the instrument maintenance logs.
- 5.5.5. A database of major instruments is maintained by the QA & DV department where instruments are logged and given an instrument number when acquired. At a minimum, the instrument information includes but not limited to the following:
  - a) serial number
  - b) manufacturer
  - c) model
  - d) detector (where applicable)

## QUALITY SYSTEMS GENERAL REQUIREMENTS

---

- e) data acquisition software (where applicable)
- f) date put to service
- g) location in the lab
- h) instrument condition (new or used)
- i) comments to record any other relevant information about the instrument

Every analytical instrument has a maintenance logbook where instrument checks are recorded. These logs shall have the instrument number, the data acquisition software version and current equipment parameter setup.

- 5.5.6.** EMAX facility was built to suit for proper instrument upkeep. Each instrument is strategically and logistically positioned in consideration for ease in handling, prevention of contamination and health hazard.
- 5.5.7.** Analytical SOPs detail the process of handling instruments when out of control. While troubleshooting is ongoing, the instruments are clearly identified by an "OUT-OF-SERVICE" tag. Instrument maintenance is recorded in their respective instrument maintenance logs and shall indicate when it was back to control.
- 5.5.8.** All instruments shall bear identification traceable to all other information relevant to its use and maintenance where applicable (e.g., records of: calibration, maintenance, analysis, etc.).
- 5.5.9.** All instruments currently used at EMAX are purposely intended for its permanent facility use only and all maintenance services are done in-house. When external use of any of the instruments is necessary or instruments are sent out for repair, the same quality control checks shall be applied prior to instrument use to ensure that the instrument is properly functioning.
- 5.5.10.** Continuing calibration checks shall be carried out in accordance to the method or the PSR.
- 5.5.11.** Correction factors, where applicable, shall be applied accordingly. Where software is elemental in applying the correction factors, (e.g., Inter-Element Correction factors, retention time windows, calibration factors, etc.) the data acquisition software is updated in accordance to the method and/or instrument requirement prior to instrument use. Where correction factors are applied in support instruments, (e. g. thermometers) readings shall be recorded as observed and corrected values.
- 5.5.12.** Access control of instruments is password protected to prevent accidental and/or intentional changes to instrument parameter setups including correction factors where applicable.
- 5.5.13.** Support Instruments
  - 5.5.13.1.** Support instruments contributory to accuracy of analytical results (e.g., balances, ovens, refrigerators, freezers, incubators, water baths, thermometers, micropipettes) shall be maintained to deliver required accuracy.
    - a) Records of repair and maintenance activities shall be maintained by the user.
    - b) Calibrations shall be verified at least once a year using traceable reference standards. Reference standards used for calibration verification in-house shall be sent to a NIST certified calibration laboratory for calibration at least once a year. Support instruments that does not have a valid calibration shall be
      - Removed from the workbench; or
      - If calibration results require correction factor, the device (e.g., thermometer, balance) shall bear the correction factor that needs to be applied to correct the measurement.
    - c) All raw data obtained during the calibration shall be recorded in their respective calibration logs.

## QUALITY SYSTEMS GENERAL REQUIREMENTS

---

- d) Calibration checks for balances shall be performed prior to its use for the day. Balances shall be checked within the expected range of use with standard weights having a valid certificate calibration.

Temperatures of refrigerators and freezers shall be checked daily with a calibrated thermometer.

Temperatures of ovens and water baths shall be checked daily or prior to its use for the day with a calibrated thermometer.

Thermometers shall be calibrated against a thermometer reference standard having a valid certificate from a NIST certified calibration laboratory or equivalent.

- e) Calibration checks for volumetric dispense devices (except Class A and glass microliter syringes) shall be performed on a quarterly basis.
- f) Performance checks, frequency and acceptance criteria for support instrument calibrations shall be performed as required by the application for which the instrument is used, otherwise adhere to the following:
- 1) EMAX-QC03 for refrigerator/freezer monitoring
  - 2) EMAX-QC04 for balance calibration check and standard mass verification
  - 3) EMAX-QC05 for thermometer calibration check and standard thermometer verification
  - 4) EMAX-QC06 for micropipette calibration check and volumetric/non-volumetric measuring labware accuracy and precision check
  - 5) EMAX-QC01 for reagent water monitoring

### 5.6. Measurement Traceability

#### 5.6.1. General

Analytical SOPs detail the required instrumentation, calibration process, analytical standards to be used and calibration validity.

#### 5.6.2. Specific Requirement

5.6.2.1. Instruments, analytical standards, calibrations (initial, verification or continuing) raw data and reports generated are all linked through documentation process for traceability purposes. Analytical standards are purchased from vendors whose measurements are linked to SI units of measure and are prepared using support instruments traceable to SI units of measure.

5.6.2.2. A valid calibration must exist prior to instrument use. Where possibility of traceability is not possible, analytical process must demonstrate that method requirement is fulfilled.

#### 5.6.3. Reference Standards and Reference Materials

5.6.3.1. Reference Standards. Where possible, reference standards are purchased as certified standards traceable to SI units of measure. Certificate of analysis shall include the purity, traceability and ISO accreditation or equivalent.

5.6.3.2. Reference Materials. Where possible, reference materials are purchased as analytical grade traceable to SI units of measure.

5.6.3.3. Intermediate Checks. Reference standards and reference materials are verified using secondary source when commercially available.

5.6.3.4. Handling and Storage. EMAX-QC02 details the process of analytical standard handling and storage.

#### 5.6.4. Documentation

## QUALITY SYSTEMS GENERAL REQUIREMENTS

---

5.6.4.1. Reference Standards or reference materials used for calibration shall be applicable for field samples, quality control samples and performance tests samples. Records of such shall be traceable in laboratory logbooks.

5.6.4.2. Documentation and labeling of analytical standards are detailed in EMAX-QC02.

### 5.7. Collection of Samples

#### 5.7.1. Sampling

Sample management establishes a process to ensure that samples are properly received and stored. It also ensures that statistically relevant representative samples are taken and that all information relevant to the sample and sub-sampling processes are recorded accordingly.

#### 5.7.2. Project Management

EMAX-QA01 details the process of disseminating PSRs. This process will also handle special instructions (changes, additions and/or deletions from a method or program requirement) to achieve project data quality objectives.

#### 5.7.3. Documentation

The internal chain-of-custody (ICOC) shall document the traffic of samples going in and out of the sample control room, who relinquished/withdrew/returned the sample(s) and when the transfers were done. Details of such process are described in EMAX-SM01.

PSR is enclosed in every work order distributed in the bench. This contains all requirements necessary to complete the work order. The process of accomplishing the PSR is detailed in EMAX-QA01.

Sample preparation logs are used to record sub-sample amounts taken for extraction, digestion, leaching, or preparation for analysis. The process is detailed in sample preparation or analytical SOPs.

### 5.8. Handling Samples and Test Items

#### 5.8.1. Handling Samples

EMAX-SM01 details the process of sample control. Every sample received is uniquely identified. Sample integrity shall be maintained during receipt, storage and retention and residual samples are disposed according to established policies and procedures.

#### 5.8.2. Test Items

Every sample analyzed is uniquely identified, may it be quality control samples, field samples, calibration samples, instrument performance samples, etc. EMAX-SM04 details the process of identifying different analytical codes in order to identify test samples distinctively. This identification is linked to all records (sample ID, logbooks, raw data, reports, calibrations, standards, etc.) for traceability purposes.

Procedures for sample handling specific to each method are described or referenced in every analytical SOP.

#### 5.8.3. Documentation

Sample handling, testing and any deviation from the standard practice or any anomaly noted during the process shall be recorded in the appropriate document. When the irregularity encountered affects the data quality objective of the project, the client shall be informed accordingly.

#### 5.8.4. Facilities

Sample control room and extract storage are maintained to ensure proper sample preservation and prevent cross-contamination. Refer to EMAX-QC04 for details.

## QUALITY SYSTEMS GENERAL REQUIREMENTS

---

Likewise, sample preparation and analytical laboratories are maintained to facilitate an environmentally friendly workplace keeping cautious consideration of contamination prevention.

### 5.9. Quality Assurance of Environmental Testing

**5.9.1.** Validity of test results is dependent on acceptability of applicable quality control measures.

- a) Appendix 1 of the analytical SOPs includes quality control procedure (QCP) that must be observed for every analytical process. Refer to analytical SOPs for details.
- b) Generally, project data quality objectives are incorporated in the project statement of work (SOW) or quality assurance project plan (QAPP). Project control limits are utilized as an on-going basis to control every sample analyzed. In the absence of project control limits, in-house control limits are applied.
- c) EMAX-QA06 – Control Chart SOP describes the process of generating and updating control limits. In addition, this SOP details the process of monitoring the different analyses performed at EMAX. This practice will identify if there are variations that are inherent to the process or random in nature. This SOP also describes interim control limits to analytes with no statistical data.
- d) Sample(s) shall be retested where validity of result is in question (e.g., contamination is suspected, over calibration range, etc.). Tentatively identified target analytes are confirmed as directed by the method.
- e) 200% data review is performed prior to data packaging, PM's completeness review is performed prior to data package delivery and QA review is performed on 10% of data packages produced on a quarterly basis. If data quality issues are discovered during the review, the client shall be notified within fifteen (15) business days of the discovery of the issue.

**5.9.2.** Re-analysis of field samples shall be performed when quality control determinant does not warrant data to be reported. In the event that re-analysis is not possible, the client is informed unless otherwise pre-existing instruction is stipulated in the contract.

**5.9.3.** Quality control samples are prepared and analyzed with field samples at a frequency required by the project. In the absence of PSR, in-house QCP is applied.

### 5.10. Reporting the Results

#### 5.10.1. General

Sample result summary forms contain all pertinent information relevant to results being reported. Details on how results are reported depend on PSR (e.g., criteria for reporting non-detects, data flagging, significant figures, etc.). Typically, these forms are accompanied with quality control summary forms where conformance (or non-conformance) to control limits is demonstrated and a case narrative summarizing the condition of the analytical process. When required, calibration summaries, preparation/analysis logs, or any other PSR are also included in reporting the results.

#### 5.10.2. Test Reports

EMAX standard reporting formats for analytical results are included in every analytical SOP. Where project deliverables require a different reporting format, the PM shall coordinate with the parties involved to determine the necessary measures to meet the project requirement.

At a minimum, test reports contain the following:

- a) Cover Letter – contains the following:

## QUALITY SYSTEMS GENERAL REQUIREMENTS

---

1. Report date
  2. Report ID – EMAX batch No.
  3. Attention line – report recipient as specified in the project
  4. Client Name
  5. Address – where report is to be delivered as specified in the project
  6. Subject – Laboratory Report
  7. Project Name
  8. Date samples were received
  9. Cross reference table with client sample IDs, EMAX lab IDs, collection date, matrix and analyses requested.
  10. Authorized report signatory and function
  11. Applicable accreditation(s)
- b) Sample result summary forms contain the following:
1. Analytical Method applied
  2. Client and Project
  3. Sample IDs (client and EMAX)
  4. Relevant Dates (sampled, received, prepared/extracted/digested/leached, analyzed)<sup>1</sup>
  5. Dilution factor
  6. Matrix
  7. Moisture content (all soil samples are reported in dry weight unless otherwise specified by the project)<sup>2</sup>
  8. Data file ID
  9. Calibration reference
  10. Preparation batch
  11. Sample results with applicable qualifiers as required by the project<sup>3</sup>
  12. Detection limits (LOQ, LOD, DL)
  13. Surrogates, as applicable (results, spike amount, recoveries)
- c) Quality Control samples summary forms (if required) contain the following:
1. QC sample IDs (client and EMAX)
  2. QC sample result
  3. Percent recovery
  4. RPD (where applicable)
  5. Project QC limits
- d) Calibration Summary forms (if required) contain the following:

---

<sup>1</sup> TNI EL-VM2-2011/DoD/DOE QSM 5.1, 5.10.11.a

<sup>2</sup> TNI EL-VM2-2011/DoD/DOE QSM 5.1, 5.10.11.b

<sup>3</sup> TNI EL-VM2-2011/DoD/DOE QSM 5.1, 5.10.11.e



## QUALITY SYSTEMS GENERAL REQUIREMENTS

---

1. Calibration data file IDs
  2. Calibration Date
  3. Results
  4. Recoveries
  5. Method required limits, unless otherwise specified by the project
- e) Case Narrative discusses the following:
1. Holding time
  2. Calibrations
  3. Applicable QCs (MB, LCS/LCD, MS/MSD/MD, MRL, etc.)
  4. Sample Analysis (manual integration, anomaly encountered, opinions and interpretations<sup>4</sup>, etc.)

### 5.10.3. Reporting Analytical Conditions

5.10.3.1. Analytical conditions shall be reported in the case narrative and shall include the following:

- a) Applicable test methods. Where deviation from applicable test method is imposed by a sample condition or any unavoidable circumstance, discussion of such shall be included in the case narrative.
- b) Statement of quality control compliance or non-compliance
- c) Reporting measurement uncertainty is only applied when required by the project.
- d) Condition of sample analysis. In instances where results are outside the norm, requiring interpretation, it shall include description of the uncharacteristic result (e.g., manual integration, non-conformance to holding time, sample storage temperature out-of-range, etc.).
- e) Statement of compliance to method and project requirement.

5.10.3.2. Data qualifiers shall be applied as required by the project. In the absence of project data qualifiers, EMAX standard qualifiers shall be applied. Refer to EMAX-DM01 for details.

5.10.3.3. Sample condition is documented in sample receipt form (SRF) as they are received in the lab. If samples received are not in a manner as expected (preservation, container, amount), discrepancies are noted in the SRF.

### 5.10.4. Calibration Certificates

EMAX Laboratories, Inc. does not issue calibration certificates.

### 5.10.5. Opinions and Interpretations

When opinions and interpretations are mandated by the condition of sample test results, they shall be discussed in the case narrative. The discussion shall include the basis upon which the opinions and/or interpretations have been made.

### 5.10.6. Test Results From Subcontractors

Test performed by subcontractors are reported as delivered by the subcontracting lab to EMAX. Likewise, the subcontractor shall be liable to the authenticity, correctness and accuracy of its report. Unless stipulated in the contract, the subcontractor shall be required to report the results in writing or electronically as specified by the project. EMAX shall retain a copy of the subcontractor's report and stores it using EMAX archival system.

---

<sup>4</sup> DoD/DOE QSM 5.1, 5.10.5

## QUALITY SYSTEMS GENERAL REQUIREMENTS

---

### 5.10.7. Electronic Transmission of Results

Electronic transmission of results shall be carried out as instructed by the project requirement. All reasonable steps to preserve confidentiality shall be taken into consideration.

### 5.10.8. Format of Report

A cover letter, chain of custody, sample receipt documentation, reports of all analyses within a sample delivery group (SDG) and other related documents essential to the sample results being reported are collated into a data package. The data package is identified by its SDG. The procedure for data package assembly is detailed in EMAX-DM03, unless otherwise directed by the project.

When informed that the data is intended for regulatory report<sup>5</sup>, report format shall be prepared as stipulated in the contract. If EMAX is responsible for generating the regulatory reports, the PM shall coordinate with the responsible parties to generate the report in accordance to the reporting requirement. However, if the client requires a different format, all pertinent information to complete the regulatory report shall be provided to the client.

### 5.10.9. Amendments to Test Reports

Where amendments to transmitted test report are necessary, a supplemental report shall be provided. The cover letter shall include what was changed and/or added and the subject line shall read:

"Supplement to Laboratory Report, [EMAX batch number]"

Where a part of the report is to replace a particular page, that page is numbered with the same number as the previous report stamped with "Revised Report". Where a page(s) is inadvertently missed and is to be added in the previous report, the whole report is repaginated and resubmitted.

When it is necessary to issue a complete new test report and no specific instruction for report re-submittal was provided by the project, the cover letter shall state that it is a full re-submittal and shall replace the previously submitted report and the subject line shall read:

"Re-submittal to Laboratory Report, [EMAX batch number]"

## 6.0 HAZARDOUS AND RADIOACTIVE MATERIALS MANAGEMENT AND HEALTH AND SAFETY PRACTICES

DoD/DOE QSM 5.3 Section 6.0 shall be implemented as applicable.

---

<sup>5</sup> TNI EL-VM2-2011/DoD/DOE QSM 5.1, 5.10.10 Exceptions



**EMAX  
QUALITY  
SYSTEMS  
MANUAL  
2019  
Rev. 5.3**

**VOLUME 1, MODULE 4,  
QUALITY SYSTEMS  
CHEMICAL TESTING**

## QUALITY SYSTEMS FOR CHEMICAL TESTING

---

### 1.0 CHEMICAL TESTING

#### 1.1. Introduction

This module details EMAX's quality culture for environmental testing activities in conjunction to Modules 1 and 2. The core of EMAX's quality culture is to continuously deliver authentic and technically valid results. This can be accomplished by consistency and conformity to quality systems and customer expectations.

#### 1.2. Scope

The important aspects of quality control are included in this module. Specific SOPs detailing the actual practice are referenced in this module.

#### 1.3. Terms and Definitions

This section shall use the same terms and definitions as described in DoD/DOE QSM 5.1 Module 2, Section 3.

#### 1.4. Method Selection

Predominantly, project statement of work (SOW), sampling plan (SAP) or quality assurance project plan (QAPP) dictates the required reference method. Where there is no specific reference method stipulated, the PM shall confer and reach an agreement with the client on which method to apply. If the client shall seek advice or its choice of method is not a valid reference method, EMAX shall provide guidance based on prior knowledge.

In general, EMAX utilizes USEPA methods; Standard Methods for the Examination of Water and Wastewater; State published methods (e.g., 8015AZ, CA Method 399-M) and other methods recognized by the environmental industry (e.g., RSK-175).

EMAX SOPs for regulatory methods are written compliant to the method with no deviations from the method requirements. Analysts performing such methods have full understanding about the regulatory requirements of these methods.

Other analytical SOPs are also written adapting the applicable reference method. Any deviations from the method are detailed in the supplementary section of the SOP.

#### 1.5. Method Validation

##### 1.5.1. Validation of Method

- a) The primary considerations for method validation are accuracy, reproducibility and determination of detection limits. Method validation shall ensure that each target analyte are qualitatively identified and quantified accurately as specified in the analytical SOP. Method validations shall be performed as described by the procedures of the relevant SOP including method deviations (if any).
- b) Non-reference methods shall undergo method development as described in EMAX-QA03.
- c) Non-reference methods shall also be validated as stated in 1.5.1 a). In addition, method precision and bias shall be evaluated.
- d) For DoD or DOE-sponsored projects, unless required by the project, consent to use non-standard methods shall be obtained prior to implementation.
- e) Method re-validation is a must when modifications cause changes in stoichiometry, technology, instrument tuning acceptance or quantitation ions.

##### 1.5.2. Limit of Detection and Limit of Quantitation

## QUALITY SYSTEMS FOR CHEMICAL TESTING

---

Determination of detection limits is detailed in EMAX-QA04. This SOP describes the process of establishing, validating and verifying detection limits (DL), limit of detection (LOD) and limit of quantitation (LOQ) and their relationships.

### 1.5.2.1. Limit of Detection (LOD)

Where reference methods specify the LOD (or determination LOD), validation or verification, the reference method requirement shall prevail. Otherwise, LOD shall be established as stated above.

DL is determined for each analyte in a given method adapting SW846 Chapter 1, Method Detection Limit section or based from historical data. A quality systems matrix shall be used in the study. It shall be subjected to the same process as sample results are determined to include sample preparation, applicable extraction cleanup, analysis, data evaluation, result quantitation and qualitative identification.

- a) LOD for each analyte per matrix is included in every analytical SOP. The samples prepared for LOD determination were also subjected to sample preparation, applicable extraction cleanup, analysis, data evaluation, result quantitation and qualitative identification.
- b) Study samples for LOD are spiked at 2-4 times the DL value. LOD is determined by the least concentration where the analyte is qualitatively and positively detected.
- c) LOD study is not applicable for analytes for which spiking solutions or quality control samples are not available or otherwise inappropriate.
- d) A method blank from the same matrix used for the LOD samples shall be prepared and analyzed along with the LOD samples to confirm absence/presence of interferences in matrix used for the study.
- e) Likewise, if there is a change in the method that may impact the sensitivity of the method as stated in 1.5.1.e, LOD verification is a required.
- f) LOD verification shall be implemented in accordance with DoD/DOE QSM 5.1, Module 4, Section 1.5.2.1.f).
- g) Frequency of LOD verification shall be done quarterly. For methods that are infrequently performed, LOD verification may be performed per analytical batch.

### 1.5.2.2. Limit of Quantitation (LOQ)

- a) LOQ for each analyte per matrix is included in every analytical SOP. Similarly, these samples are processed like LOD.
- b) LOQ study is not applicable for analytes for which spiking solutions or quality control samples are not available or otherwise inappropriate.
- c) For multi-point calibration methods, study samples for LOQ are spiked at the concentration of the lowest calibration point. LOQ must be within the established LOQ acceptance limits.
- d) LOQ must be greater than LOD.
- e) Frequency of LOQ verification shall be done quarterly. For methods that are infrequently performed, LOQ verification may be performed per analytical batch.

### 1.5.3. Evaluation of Precision and Bias

- a) Reference Methods. In the absence of reference method guidance, determine precision and bias for each analyte per quality system matrix according to Section 1.6 of this module or from historical LCS data of at least 20 points.
- b) Non-reference Methods. Currently EMAX does not have any non-reference methods employed. In the event that EMAX shall develop one, precision and bias shall be established as prescribed in TNI EL-V1M4-2011.1.5.3.b or TNI Standard latest version.

### 1.5.4. Evaluation of Selectivity

## QUALITY SYSTEMS FOR CHEMICAL TESTING

---

Selectivity is evaluated to extent of which analytes of interest can be qualitatively identified and quantitatively determined without interferences from other target analytes on a given matrix. Acceptance criteria for selectivity are generally prescribed by the reference method and are commonly demonstrated by the instrument performance check. Refer to analytical method for details.

### 1.6. Demonstration of Capability (DOC)

#### 1.6.1. General

The biggest contributor of the quality output are the personnel dealing with the entire analytical process. This process starts from the time samples are received until all the deliverables are submitted. It is a must that all laboratory personnel who take part in the process are adequately qualified.

Only competent personnel are assigned to perform a given task. Every laboratory employee hired shall undergo training and initial demonstration of capability is completed regardless of education, experience or training prior to its employment at EMAX. Continuing demonstration of capability shall be evaluated once a year thereafter.

Training records of laboratory personnel shall be maintained by the Quality Assurance and Data Validation (QA & DV) department. SOP for training is detailed in EMAX-QA05.

#### 1.6.2. Initial DOC

Initial DOC is performed prior to initial use of a method and every time a method re-validation is done (refer to 1.5.1.e of this module). Initial DOC is also completed when in a period of twelve (12) months the method was not used or the analyst has not performed such method.

1.6.2.1. Initial DOC shall be documented as described in EMAX-QA05.

1.6.2.2. Method requirements for demonstrating proficiency must be observed. If the method does not specify initial demonstration of capability, the procedures described in EMAX-QA05 shall be completed.

#### 1.6.3. Ongoing DOC

The process of evaluating ongoing DOC is also described in EMAX-QA05.

### 1.7. Technical Requirements

#### 1.7.1. Initial Calibration (ICAL)

##### 1.7.1.1. Instrument Calibration

Accuracy of test results is highly dependent on instrument calibration. Understanding method calibration specificity and instrument operational instructions are essential factors in achieving proper calibration. To ensure that calibration is appropriately pursued specific to method/instrument, instrument parameter setup and calibration procedures are detailed in every analytical SOP.

- a) Calibration is initiated by performing ICAL. Analytical SOPs detail the ICAL process including analytical standards (source, preparation, concentration levels, and target analytes), instrument parameter setup, analysis, evaluation, calculations, acceptance criteria, application and review.
- b) Raw data are uniquely identified. They are retained in its original form and edited form (if any) traceable to the instrument identification and ICAL.
- c) Primarily, analyte results shall be quantitated based on ICAL, unless otherwise instructed by the method and/or by the project.
- d) ICAL are verified with an initial calibration verification standard (ICV) obtained from a secondary source. The primary standard and the secondary source standard may be obtained from same vendor as long as the

## QUALITY SYSTEMS FOR CHEMICAL TESTING

---

- secondary source standard is identified as a second source standard (e.g., independently prepared from a different source material). Acceptance criteria shall be based on the project requirement.
- e) Acceptance criteria for calibrations are also specified in specific analytical SOPs, unless otherwise instructed by the project.
  - f) Any value detected below the established LOQ shall be reported in accordance to project requirement.
  - g) Generally, quantitation range is bracketed by the lowest and the highest calibration points, unless otherwise instructed by the method. Any value above the quantitation range shall be diluted to an estimated factor to bring values within the calibration range or shall be flagged in accordance to the project requirement.
  - h) Where calibration is standardized with a zero and a single point calibration (IPC, ICP-MS), linear range must be established and verified as required by the method and LOQ verification must be analyzed in addition to the method calibration requirements.
  - i) When initial calibration does not meet the established acceptance criteria, analytical run shall be aborted; cause of non-conformance shall be evaluated and necessary corrective action shall be applied. Sample analysis shall not commence until a valid initial calibration is completed.
  - j) All target analytes, as well as surrogates and internal standards (as applicable) shall be included in the ICAL. In the absence of PSR, procedure for initial calibration as described in the analytical SOPs shall be implemented. Analytical SOPs also include qualitative identification, quantitative determination and ICAL evaluation. Refer to analytical SOPs for details.

### 1.7.2. Continuing Calibration

Where applicable, continuing instrument calibration verification (CCV) is performed as specified by the method, unless otherwise instructed by the PSR. Instrument calibration verification shall include the following elements:

- a) Procedure  
Detailed procedure on how continuing calibration is performed. Refer to analytical SOPs.
- b) Analytes  
CCV standards shall include all target analytes except for multi-component analytes (e.g., aroclors, chlordane, toxaphene, TPHs). CCV for such analytes shall be run separately, as necessary.  
Concentration of CCV shall be greater than the low calibration standard and less than or equal to the midpoint of the calibration range<sup>6</sup>.
- c) Frequency
  - i. At the beginning of every analytical batch
  - ii. At interval required by the method
  - iii. When the last calibration verification is expired
- d) Records  
All pertinent records shall be retained to permit reconstruction of the CCV. Traceability to the instrument, ICAL, method, analysis date, analyte (name, concentration, response, etc.) shall be made apparent.
- e) Acceptance Criteria

---

<sup>6</sup> DoD/DOE QSM 5.1, Module 4,1.7.2.c.iv

## QUALITY SYSTEMS FOR CHEMICAL TESTING

---

CCV shall be evaluated against the acceptance criteria as described in the specific analytical SOP. All CCVs must be evaluated and reported in accordance to project requirement. If a CCV is outside the acceptance criteria, corrective action shall be applied.<sup>7</sup>

For DoD/DOE-sponsored projects:

- i. If CCV is outside the acceptance criteria and no samples were run after the CCV, two consecutive CCVs can be analyzed to rule out incongruous results.
- ii. If both CCVs passed then the results may be reported.
- iii. If one of the CCVs failed, determine and fix the problem, then recalibrate.
- iv. Re-analyze all samples associated with the non-compliant CCV.
- v. In the event that re-analysis cannot be done, the PM shall be notified ASAP for further action.

For other projects:

- i. If CCV is bias high and no analyte was detected on the associated samples, then results can be reported. CCV condition shall be discussed in the case narrative.
- ii. If CCV is bias low and target analytes are detected above the action level, results can be reported. CCV condition shall be discussed in the case narrative.
- iii. Otherwise, determine and fix the problem. Recalibrate and re-analyze all samples associated with the non-compliant CCV.

### 1.7.3. Quality Control

Quality control samples required for each method are included in the respective SOPs. They are prepared and analyzed at a frequency prescribed by the project.

For DoD/DOE-sponsored projects, in the absence of PSR, DoD/DOE QSM, Appendix B, method specific quality control requirements shall be implemented.

In the absence of PSR, the in-house requirements shall be in effect.

#### 1.7.3.1. Negative Control – Method Performance: Method Blank

- a) Function. Method blank (MB) is used to confirm that no contaminant is introduced during the analytical process; hence it is prepared and analyzed using the same process as the field samples.
- b) Frequency. MB is prepared in every preparation batch.
- c) Matrix. MB matrix shall be similar to the field sample matrix being analyzed. EMAX utilizes reagent water for water samples, target analyte interference-free solid matrix for other soil samples.  
  
Where methods require surrogate spikes, method blank sample is also spiked with surrogate.
- d) Application. MB is required, when extraction, clean-up, digestion, leaching or purging process is involved or when something is added into the sample and/or the sample goes through a process where contamination may occur.

#### 1.7.3.2. Positive Control – Laboratory Control Sample

- 1.7.3.2.1. Function. Laboratory control sample (LCS) is used to determine the efficiency of the analytical process to include sample preparation, clean-up (when performed) and analysis. This control sample is prepared and analyzed using the same process as the field samples.

---

<sup>7</sup> DoD/DOE QSM 5.1, Module 4,1.7.2.d



## QUALITY SYSTEMS FOR CHEMICAL TESTING

---

1.7.3.2.2. Frequency. LCS is prepared in every preparation batch.

1.7.3.2.3. Matrix. LCS matrix shall be similar to the field sample matrix being analyzed. EMAX utilizes reagent water for water samples, target analyte interference-free solid matrix for other soil samples.

Alternatively, a certified reference material (CRM) may be used for LCS.

Component. LCS shall be spiked with analytes and surrogate(s) as required by the project; otherwise, refer to analytical SOPs for details.

Concentration. If LCS spike concentration for the project is not specified, LCS concentration shall be at or below the midpoint of the calibration range.

1.7.3.2.4. Application. This is applicable to all methods where analytical standards used are amenable to spiking (or where CRM) and standard is commercially available.

### 1.7.3.3. Sample Specific Control

#### 1.7.3.3.1. Matrix Spike/Matrix Spike Duplicate (MS/MSD)

a) Function. MS/MSDs are analyzed to determine the effectiveness of the analytical process in the sample matrix. These samples are generally designated by the project to fit the project data quality objectives. These samples are prepared and analyzed the same way as the field samples that are included in the preparation batch.

b) Frequency. MS/MSDs are prepared and analyzed at the frequency prescribed by the project. In the absence of MS/MSD specific requirement, the method requirement is applied.

c) Matrix. Generally, for every given matrix, one MS/MSD sample is designated (or chosen in the lab) in every 20 field samples or a fraction thereof granting that sufficient samples are received.

Component. MS/MSD shall be spiked with analytes and surrogate(s) as required by the project; otherwise, refer to analytical SOPs for details.

Concentration. If MS/MSD spike concentration for the project is not specified, MS/MSD concentration shall be at or below the midpoint of the calibration range.

MS QC Limits. Project MS/MSD QC limits shall be used unless directed to use EMAX QC limits. EMAX QC limits are statistically derived from historical data. Refer to EMAX-QA06 for details.

d) Application. This is applicable to all methods where analytical standards used are amenable to spiking and standard is commercially available.

#### 1.7.3.3.2. Surrogate

a) Function. Surrogate(s) is also a positive control with properties that mimic the analytes of interest. Its measurement will be indicative of the effectiveness of detecting the target analytes in the sample.

b) Frequency. Where methods require surrogate(s), each sample (including MB, LCS, MS/MSD samples) is spiked with surrogate(s).

c) Component. Surrogate(s) to be used are specified by the project. Otherwise, surrogate(s) to be used shall be as listed in the analytical SOPs.

Concentration. Unless surrogate concentration is specified by the project or mandated by the method, concentration levels for surrogate(s) shall be as prescribed in the analytical SOPs.

Surrogate QC Limits. Project Surrogate QC limits shall be used unless directed to use EMAX QC limits. EMAX QC limits are statistically derived from historical data. Refer to EMAX-QA06 for details.

d) Application. This is applicable to all methods where surrogate is required by the method.

## QUALITY SYSTEMS FOR CHEMICAL TESTING

---

### 1.7.3.4. Data Reduction

Procedures for data reduction are included in every analytical SOP.

### 1.7.3.5. Reagent Quality, Water Quality and Checks

- a) Reagents are obtained in accordance to method specific purity requirements. Where reagent purity is not specified, analytical reagent grade or better is obtained. Refer to analytical SOPs for details.
- b) Reagent water is either produced in-house or purchased commercially. Both sources of reagent water are checked for its usability prior to use. Refer to EMAX-QC01 for details.
- c) Quality control for chemicals specific to their use is detailed in EMAX-QC01. LCS/MS Spiking standards for extractable for every preparation and titrants are verified prior to use.

### 1.7.3.6. Selectivity

Procedure for qualitative identification of every analyte is detailed in the specific analytical SOP.

- a) Tentative analyte identifications are confirmed following the reference method confirmation technique.
- b) Reporting analytes requiring confirmation shall follow the PSR. In the absence of PSR, the method reporting requirements shall be implemented. Otherwise, result shall be reported from the primary column or detector. Should there be a scientific valid reason not to report results as described above, the rationale shall be documented and discussed in the case narrative.
- c) If tentatively identified analytes cannot be confirmed, the client shall be notified. Unconfirmed results shall be identified by a qualifier flag as specified by the project and shall be discussed in the case narrative.

## 1.7.4. Data Acceptance/Rejection Criteria

### 1.7.4.1. Negative Control – Method Performance: Method Blank

The result of method blank shall be a measure to determine if the samples that were prepared and processed with it are contaminant-free.

Acceptance Criteria: If result is  $< \frac{1}{2}$  of LOQ then results are considered free from contamination, otherwise corrective action is required if:

- a) the concentration  $> \frac{1}{2}$  the LOQ and is  $> 1/10^{\text{th}}$  the amount measured in any associated sample or  $1/10^{\text{th}}$  the regulatory limit, whichever is greater.
- b) the analyte is a common lab contaminant and concentration is  $> \text{LOQ}$

Corrective Action: Determine and eliminate the source of contamination. Reprocess all associated samples with necessary control samples.

### 1.7.4.2. Positive Control – Method Performance: Lab Control Sample

- a) The result of LCS is a determinant of the accuracy of the process. Project LCS control limits shall be used unless directed to use EMAX LCS limits. EMAX QC limits are statistically derived from historical LCS data. Refer to EMAX-QA06 for details.

Acceptance Criteria: If result is within LCS control limits then the process is in control, otherwise LCS shall be assessed as follows:

- i. When result is biased high and associated samples are non-detects, then the data may be reported with appropriate data qualifier. The PM shall be informed for further instruction.

## QUALITY SYSTEMS FOR CHEMICAL TESTING

- ii. When result is biased low and associated sample results exceed the regulatory limit/action level, then the data may be reported with appropriate data qualifier. The PM shall be informed for further instruction.
- b) Allowable Marginal Exceedances (ME). Driven by the nature of analytical process, at times long list of analytes may tend to have a few analytes that are marginally out of the specified/determined control limits. This may not necessarily signify that the process is out of control.

ME limits are established at  $\pm 4$  standard deviation from the mean. Result outside control limits but inside ME limits is determined as an *[allowable]* marginal exceedance.

Where projects permit ME application of allowable ME shall adhere to rules set forth by the project. For DoD/DOE-sponsored projects, ME is not allowed for target analytes identified as critical deciding factors (e.g., risk drivers). If ME is allowed and no specific rules are stipulated in the statement of work or in the QAPP, the following guidance shall be applied:

| Number of Analytes in LCS | Number of Allowable ME |
|---------------------------|------------------------|
| > 90                      | 5                      |
| 71 – 90                   | 4                      |
| 51 – 70                   | 3                      |
| 31 – 50                   | 2                      |
| 11 – 30                   | 1                      |
| < 11                      | 0                      |

- c) For DoD/DOE-sponsored project, application of ME shall be applied if the project statement of work or QAPP allows ME application or consent to apply ME is obtained.
- d) Analytes observed exceeding of control limits two (2) out of three (3) consecutive LCS and are not categorized as poor performers are indicative of systemic problem. Determine cause and resolve the issue. Hence, ME is not to be allowed for these analytes.

### 1.7.4.3. Sample Specific Control

- a) Matrix Spike/Matrix Spike Duplicate

Recovery of MS/MSD is a determinant of accuracy of results on a given matrix. RPD of MS and MSD results is a determinant of precision assuming that the matrix is homogeneous. Project MS/MSD control limits shall be used unless directed to use EMAX MS/MSD limits. EMAX QC limits are statistically derived from historical MS/MSD data. Refer to EMAX-QA06 for details.

Recoveries for MS/MSD are compared to the MS/MSD QC limits and RPD is compared to RPD limits. Project required corrective action shall be adhered to if any analyte exceeded the specified control limits. Otherwise, corrective action specified in the analytical SOPs shall be implemented.

- b) Matrix Duplicate

Matrix duplicate (MD) samples are analyzed mainly to determine precision and/or sample homogeneity. Although this QC sample is generally prescribed for metals and inorganic analyses, it may also be done for organic analyses mostly driven by the project data quality objectives.

When MD is analyzed, the relative percent difference or absolute percent difference is determined and compared to the project RPD (or %D) limits. In the absence of project RPD (or %D), in-house limits are applied. Results are reported as required by the project.

## QUALITY SYSTEMS FOR CHEMICAL TESTING

---

### c) Surrogates

Recovery of surrogates on a given sample is a gauge of accuracy of target analytes detected on a given sample. Recoveries shall be evaluated against project surrogate control limits otherwise, in-house limits shall be used. When recovery exceeded surrogate control limits, project prescribed corrective action shall be applied. When re-analysis is necessary, it shall be performed unless prohibiting factors are present (e.g., re-analysis will cause damage to instrument or chromatography obviously display qualitative and quantitative quandary).

### 1.7.5. Sample Handling

#### a) Thermal Preservation

Samples are generally received on coolers cooled by ice unless thermal preservation is not required. Temperature is checked and documented in accordance to EMAX-SM02 SOP for Sample Receiving.

#### b) Chemical Preservation

Samples that are chemically preserved are also checked and documented during sample receipt with the exception of the samples that are not amenable to be opened or sub-sampled prior to analysis (e.g., samples for volatile analyses, oil and grease). Details for this procedure are also described in EMAX-SM02.

#### c) Holding Time

Sample holding time is checked against the COC sampling date and time. Maximum holding time for analyses are listed in EMAX-SM02.

For a test with recommended maximum holding time measured in hours, the holding time is tracked by the hour. For a test with recommended maximum holding time measured in days, the holding time is tracked by the day. For a test with a recommended maximum holding time measured in months, the holding time shall be tracked by the month. One month is defined as 30 days.

#### d) Start Time Determination

For extraction, the moment that extraction solvent touches the sub-sample determines the start time. For analysis, the moment that the extract (or sample) is introduced into the analytical instrument determines the start time.



# **APPENDIX**

**A – REFERENCES**

**B – EMAX ORGANIZATION &  
MANAGEMENT**

## REFERENCES

---

1. The NELAC Institute (TNI) Standard, Environmental Laboratory Sector, Volume 1, 2011
2. Department of Defense (DoD) Department of Energy (DOE) Consolidated Quality Systems Manual (QSM) for Environmental Laboratories , DoD QSM Manual version 5.1, 2017
3. International Standard ISO/IEC 17025:2005(E)
4. U. S. EPA Drinking Water Methods for Chemical Parameters
5. U. S. EPA Methods for Chemical Analysis of Water and Wastes
6. U. S. EPA Hazardous Waste Test Methods / SW-846
7. Standard Methods for the Examination of Water and Wastewater, 21<sup>st</sup> Edition (2011) and 20<sup>th</sup> Edition (2005)

## EMAX ORGANIZATION & MANAGEMENT

### B-1 Management Structure

---

#### B-1.1 MANAGEMENT STRUCTURE

EMAX has over 70 staff members in its 27,000 square foot facility. Management Structure is detailed in Figure 1 and Laboratory structure is detailed in Figure 2.

Its technical functions are accomplished by the collective and unified effort of three departments, the Quality Assurance & Data Validation, Project Management, and Lab Operations. Although these departments function independently, internal communications and good collaboration are integrated to achieve one common goal – deliver data in accordance to project specific requirements. In summary these functions are illustrated below.

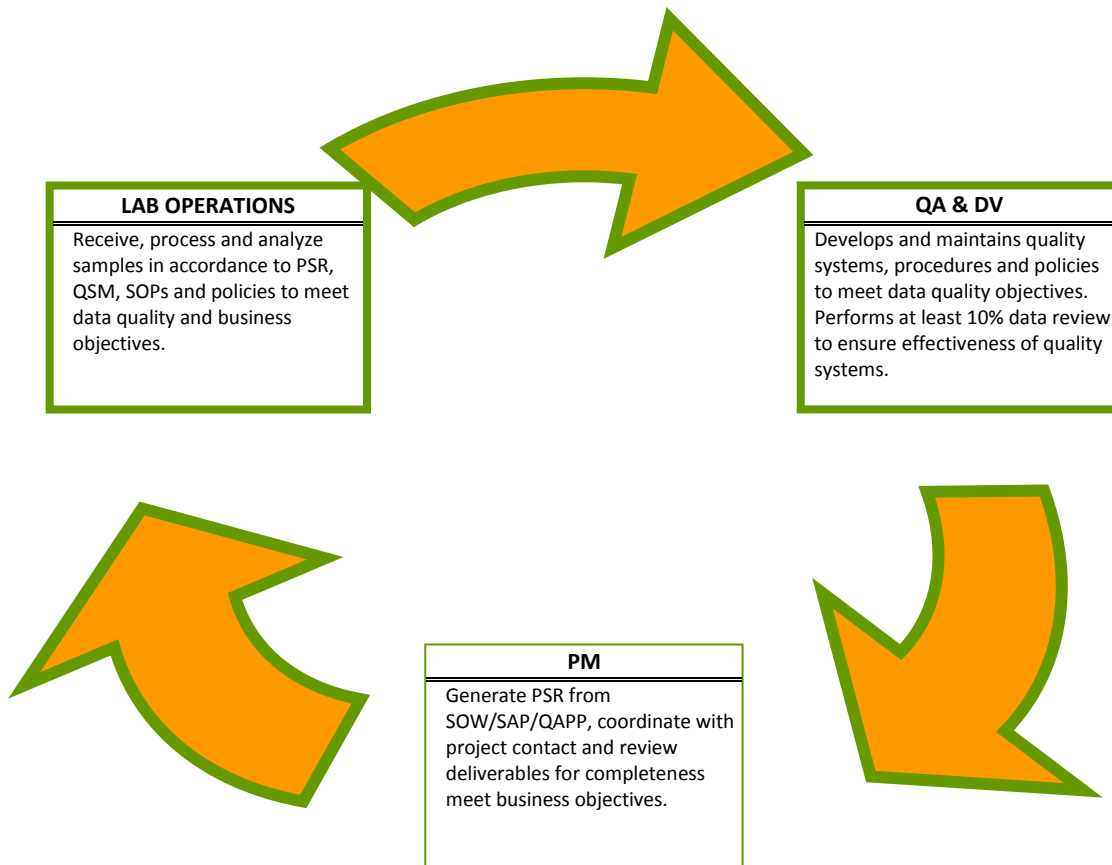

#### B-1.2 MINIMUM QUALIFICATIONS AND RESPONSIBILITIES

##### B-1.2.1 LABORATORY DIRECTOR

###### B-1.2.1.1 Minimum Qualifications

- Bachelor's degree with a minimum of 24 units of chemistry , 24 units of business management and
- Five years of laboratory experience directly related to environmental analytical services, including at least three years of supervisory experience.

## EMAX ORGANIZATION & MANAGEMENT

### B-1 Management Structure

---

#### B-1.2.1.2 Minimum Responsibilities

- Provide intellectual leadership in technical operations, project management and logistics of domain technical knowledge;
- Provide a healthy work environment
- Interface with Operations and Quality Assurance in the formulation and implementation of the Quality Systems;
- Ensure clear and consistent communication, and coordinate a team of professionals and their respective departments to promote positive corrective action in solving encountered problems;
- Drive project management activities to influence quality output with the goal of enhancing customer satisfaction;
- Review the effectiveness of Quality Systems and instigate improvement accordingly;
- Delegate deputies in case of absence of the Laboratory Director, Technical Operations Manager and/or Quality Assurance Manager;

#### B-1.2.2 TECHNICAL OPERATIONS MANAGER

##### B-1.2.2.1 Minimum Qualifications

- Bachelor's degree in chemistry or any science/engineering discipline and
- Five years of laboratory experience in analytical field, including at least three years of supervisory experience.

##### B-1.2.2.2 Minimum Responsibilities

- Provide direction in technical operations, guidance of project execution and assessment of operations capacity.
- Certify quality of technical staff to perform the test methods specified in this manual.
- Plan and adjust work operations to meet various project requirements or quick turn-around-time without sacrificing the quality and quantity of work;
- Coordinate and integrate the work activities and resources of the different departments or organizational segments;
- Analyze laboratory organizational structure and operational problems and develop timely and economical solutions;
- Establish performance goals and assess progress toward their achievement;
- Effectively deal with the department supervisors and assume their tasks in their absence.
- Assumes technical responsibilities of the Laboratory Director as necessary and perform secondary data review as needed;
- Devise ways to accommodate work operations to new and changing programs or requirements such as method development and staffing



## EMAX ORGANIZATION & MANAGEMENT

### B-1 Management Structure

---

#### **B-1.2.3 QA MANAGER**

##### **B-1.2.3.1** Minimum Qualifications

- Bachelor's degree in chemistry or any science/engineering discipline and
- Five years of laboratory experience, including at least one year of applied experience dealing with QA principles and practices in an analytical laboratory.

##### **B-1.2.3.2** Minimum Responsibilities

- Serve as the focal point for quality assurance and be responsible for maintaining the Quality Systems Manual;
- Performs at least 10 % of data package produced; evaluates data objectively and perform assessments independently from laboratory operations, without outside or management influence;
- Evaluates the appropriateness and effectiveness of corrective action taken for non-conforming events and notify the laboratory management of any deficiency requiring resolution or further action;
- Responsible for annual internal assessment of the laboratory and ensure that assessment findings are acted upon on a timely manner;
- Certify quality of technical staff to perform the test methods specified in this manual;
- Responsible for ensuring continuous improvement of the quality systems through process knowledge, the use of lessons learned from non-conforming events, proficiency testing, internal audits, control charts and management reviews;
- Assumes technical responsibilities of the Laboratory Director as necessary;

#### **B-1.2.4 PROJECT MANAGER**

##### **B-1.2.4.1** Minimum Qualifications

- Bachelor's degree in chemistry or any science/engineering discipline and
- Three years of analytical laboratory experience including sample analysis, data validation, and QA activities.

##### **B-1.2.4.2** Minimum Responsibilities

- Review project requirements;
- Generate technical summary of project specific requirements (PSR), including test methods, reporting limits, QC procedures and QC limits;
- Review data packages for completeness in accordance to PSR
- Maintain a line of communication and documentation of all transactions with the client.
- Initiate request for variance whenever necessary and disseminate project change orders to respective parties.

## EMAX ORGANIZATION & MANAGEMENT

### B-1 Management Structure

---

#### B-1.2.5 DEPARTMENT SUPERVISORS

##### B-1.2.5.1 Minimum Qualifications

- Bachelor's degree in chemistry or any science/engineering discipline and
- Three years of analytical laboratory experience, including at least one year of supervisory experience.

##### B-1.2.5.2 Minimum Responsibilities

- Assign and review the work of subordinates;
- Train and work effectively with subordinates;
- Accomplish the quantity of work expected within set limits of cost and time employing the quality systems of EMAX;
- Plan own work and carry out assignments effectively;
- Arrange for or conduct maintenance of instrumentation to produce quality data and minimize downtimes;
- Review and resolve reported anomalies;
- Communicate and resolve work related concerns or challenges and institute preventive measures moving forward;
- Ensure initial and continuing demonstration of capability of subordinates;
- Review and revise test methods related to respective work as necessary;
- Understand and advance management goals as these affect day-to-day work operations; and
- Develop improvements or design new test methods through method development process;

#### B-1.2.6 ANALYSTS

##### B-1.2.6.1 Minimum Qualifications

- Bachelor's degree in chemistry or any science/engineering discipline or in lieu of minimum education requirement, four years experience in operating and maintenance in the related field of service.
- Two years experience in related field of service, such as GC/MS, GC, ICP, etc.

##### B-1.2.6.2 Minimum Responsibilities

- Complete initial demonstration of capability before assuming responsibility and ensure continuing demonstration of capability in accordance with the quality systems;
- Plan own work and carry out assignments effectively
- Review and employ appropriate test methods and SOPs related to respective works;
- Perform first level of 100% review on sample results in accordance to work order specifications, method requirements and as described in EMAX-DM01.
- Report anomalous circumstances to the Supervisor or the Operations Manager; and
- Accomplish the quality and quantity of work expected within set limits of cost and time;

## EMAX ORGANIZATION & MANAGEMENT

### B-1 Management Structure

---

#### B-1.2.7 TECHNICIANS

##### B-1.2.7.1 Minimum Qualifications

- High school diploma and a college level course in general chemistry or one-year experience of laboratory work.

##### B-1.2.7.2 Minimum Responsibilities

- Complete initial demonstration of capability before assuming responsibility and ensure continuing demonstration of capability in accordance with the quality systems;
- Plan own work and carry out assignments effectively
- Review and employ appropriate test methods and SOPs related to respective works;
- Report anomalous circumstances to the Supervisor or the Operations Manager; and
- Accomplish the quality and quantity of work expected within set limits of cost and time;

#### B-1.2.8 NETWORK ADMINISTRATOR MANAGER

##### B-1.2.8.1 Minimum Qualifications

- Bachelor's degree in computer or any science/engineering discipline with advanced training in information management, database management systems, or systems requirements analysis.
- Three years experience in data or systems management or programming including one year experience in laboratory information management system operations.

##### B-1.2.8.2 Minimum Responsibilities

- Implement and administer network security policy as described in EMAX-IS08;
- Perform and monitor network backup jobs and process restore requests as well as perform configuration of workstations and mail server as described in EMAX-IS09;
- Manage network password and access control by establishing and maintaining users in regard to their files, rights, and account restrictions. Establish virus protection and perform virus disaster recovery as described in EMAX-IS10;
- Execute software or system releases as requested and maintain documentation of new hardware purchase as described in EAMX-IS12;
- Perform proactive review of systems performance and alerts to ensure that systems are properly protected on a regular basis;
- Review system logs to identify signs of potential problems;
- Review and revise as necessary, all SOPs related to network activities.
- Stay current on technologies affecting current systems infrastructure issues
- Respond to users request on problems encountered regarding hardware, commercially purchased software or any other related network.
- Install, configure, and maintain software and applications needed by the operations.
- Initiate improvements on design systems to meet the industry demand.

## EMAX ORGANIZATION & MANAGEMENT

### B-1 Management Structure

---

#### **B-1.2.9 SAMPLE MANAGEMENT SUPERVISOR**

##### **B-1.2.9.1** Minimum Qualifications

- Associate's degree with two years of laboratory experience in sample management and at least one year of supervisory experience.

##### **B-1.2.9.2** Minimum Responsibilities

- Supervise sample management as described in the sample management SOPs;
- Check that the sample control room is within the prescribed condition as described in EMAX-QC03.
- Train and work effectively with subordinates;
- Accomplish the quantity of work expected within set limits of cost and time employing the quality systems of EMAX;
- Plan own work and carry out assignments effectively;
- Arrange for or conduct maintenance of sample storage refrigerators/freezers to minimize downtimes;
- Review and resolve reported anomalies when they are encountered;
- Communicate and resolve work related concerns or challenges and institute preventive measures moving forward;
- Ensure initial and continuing demonstration of capability of subordinates;
- Review and revise test related SOPs respective to work practices and/or project requirements as necessary;
- Understand and advance management goals as these affect day-to-day work operations; and
- Initiate improvements on sample management systems to meet the industry demand.

#### **B-1.2.10 HEALTH AND SAFETY OFFICER**

##### **B-1.2.10.1** Minimum Qualifications

- Bachelor's degree in chemistry or any science/engineering discipline, with 40-hour training on Hazardous Waste Management.
- One-year experience in administering health and safety regulations.

##### **B-1.2.10.2** Minimum Responsibilities

- Responsible for lab safety policies and procedures and lab safety orientation of new hires.
- Management of employee injuries and exposures to include following up with occurrences, looking at trends and instituting work practice control changes if necessary.
- Regular safety audits which should include fire and electrical safety, ergonomics, chemical hygiene, general housekeeping, waste management, personal protective equipment, and infection prevention.
- Periodic health and safety training for laboratory personnel which includes spill training, fire extinguisher training, fire drills, and several other related health and safety topics.

## EMAX ORGANIZATION & MANAGEMENT

### B-1 Management Structure

---

- Responsible for waste management ensuring proper labeling and disposal of laboratory generated wastes and residual samples.

#### **B-1.2.11. QA & DATA VALIDATION SUPPORT STAFF**

##### **B-1.2.11.1** Minimum Qualifications

- High School Diploma.
- Two years experience as office support staff or associate degree with computer literacy.

##### **B-1.2.11.2** Minimum Responsibilities

- Assist with quality assurance activities.
- Perform processing and assembly of data deliverables.
- Process requests for laboratory logbooks and templates.
- Update and maintain employee training records.
- Process SOP revisions.
- Update and maintain EMAX Browser.
- Perform other duties as assigned.

## EMAX ORGANIZATION & MANAGEMENT

### B-1 Management Structure

Figure 1: MANAGEMENT STRUCTURE

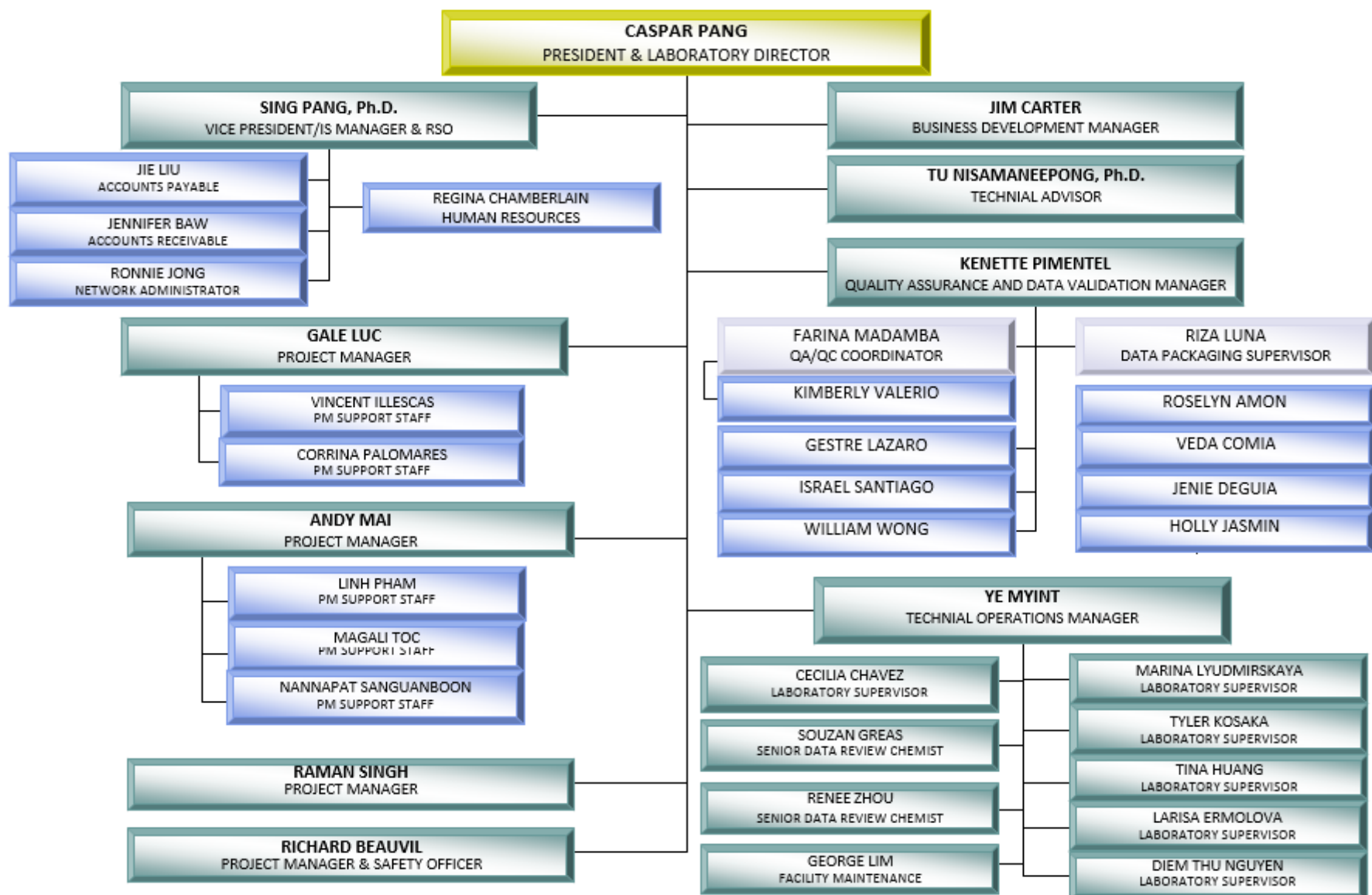

## EMAX ORGANIZATION & MANAGEMENT

### B-1 Management Structure

Figure 2: LABORATORY STRUCTURE

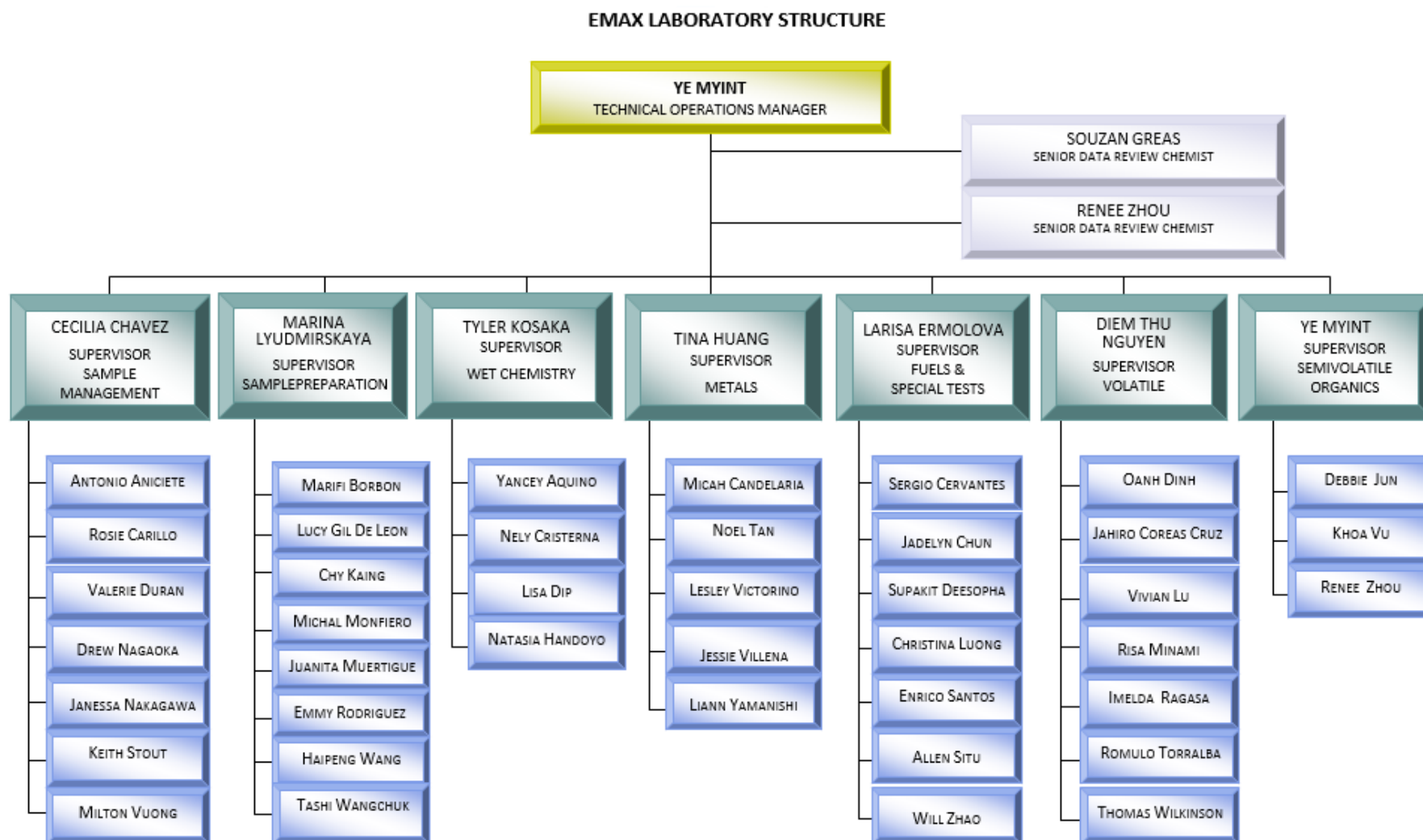

## EMAX ORGANIZATION & MANAGEMENT

### B-2 List of Standard Operating Procedures

| EMAX SOP LISTS |        |                |   |
|----------------|--------|----------------|---|
| ANALYTICAL     |        |                |   |
| EPA METHODS    |        |                |   |
| SOP #          | Rev. # | Effective Date | TITLE   |
| EMAX-120.1     | 8      | 9/19/2018      | SPECIFIC CONDUCTANCE                                  |
| EMAX-150.1     | 8      | 9/19/2018      | pH MEASUREMENT  |
| EMAX-180.1     | 9      | 9/19/2018      | TURBIDITY BY NEPHELOMETRIC METHOD                     |
| EMAX-200.7     | 5      | 8/24/2017      | DETERMINATION OF METALS AND TRACE ELEMENTS BY ICP-AES |
| EMAX-200.8     | 6      | 10/30/2018     | TRACE METALS BY ICP-MS                                |
| EMAX-218.6     | 7      | 7/26/2019      | HEXAVALENT CHROMIUM                                   |
| EMAX-245.1     | 4      | 7/15/2016      | MERCURY (MANUAL COLD VAPOR)                           |
| EMAX-300.0     | 12     | 8/24/2017      | ION CHROMATOGRAPHY ANALYSIS                           |
| EMAX-300M      | 4      | 12/7/2018      | ION CHROMATOGRAPHY ANALYSIS FOR ORGANIC ACIDS         |
| EMAX-314.0     | 5      | 2/28/2017      | PERCHLORATE BY ION CHROMATOGRAPHY ANALYSIS            |
| EMAX-410.4     | 5      | 9/19/2018      | CHEMICAL OXYGEN DEMAND (COLORIMETRIC, MANUAL)         |
| EMAX-420.1     | 4      | 9/18/2017      | TOTAL PHENOLS BY SPECTROPHOTOMETRY                    |
| EMAX-504.1     | 6      | 6/10/2019      | EDB AND DBCP  |
| EMAX-524.2     | 9      | 7/17/2015      | PURGEABLE ORGANIC COMPOUNDS IN WATER BY GC/MS         |
| EMAX-608       | 2      | 12/24/2014     | ORGANOCHLORINE PESTICIDES & PCBs                      |
| EMAX-624       | 4      | 6/29/2011      | VOLATILE ORGANICS BY GC/MS                            |
| EMAX-625       | 1      | 8/22/2011      | SEMIVOLATILE ORGANICS BY GC/MS                        |



## EMAX ORGANIZATION & MANAGEMENT

### B-2 List of Standard Operating Procedures

| EMAX SOP LISTS   |        |                |   |
|------------------|--------|----------------|---|
| ANALYTICAL       |        |                |   |
| STANDARD METHODS |        |                |   |
| SOP #            | Rev. # | Effective Date | TITLE   |
| EMAX-2120B       | 5      | 8/24/2018      | COLOR (COLORIMETRIC-PLATINUM-COBALT)                  |
| EMAX-2130B       | 7      | 9/14/2018      | TURBIDITY BY NEPHELOMETRIC METHOD                     |
| EMAX-2150B       | 1      | 10/11/2017     | ODOR  |
| EMAX-2310B       | 3      | 9/12/2018      | ACIDITY   |
| EMAX-2320B       | 5      | 8/24/2017      | ALKALINITY  |
| EMAX-2340B       | 4      | 8/24/2018      | HARDNESS BY CALCULATION                               |
| EMAX-2340C       | 4      | 4/30/2018      | HARDNESS, TOTAL                                       |
| EMAX-2510B       | 6      | 9/12/2018      | SPECIFIC CONDUCTANCE                                  |
| EMAX-2540B       | 4      | 4/30/2018      | TOTAL SOLIDS  |
| EMAX-2540C       | 9      | 4/30/2018      | TOTAL DISSOLVED SOLIDS                                |
| EMAX-2540D       | 6      | 4/30/2018      | TOTAL SUSPENDED SOLIDS                                |
| EMAX-2540F       | 4      | 4/30/2018      | SETTLABLE SOLIDS                                      |
| EMAX-3500-FeB    | 5      | 9/18/2017      | FERROUS IRON BY PHENATHROLINE                         |
| EMAX-4110B       | 5      | 12/3/2015      | ION CHROMATOGRAPHY ANALYSIS                           |
| EMAX-4500-CIB    | 3      | 9/12/2018      | CHLORIDE (ARGENTOMETRIC)                              |
| EMAX-4500-CNE    | 6      | 4/17/2019      | CYANIDE, TOTAL  |
| EMAX-4500HB      | 5      | 9/12/2018      | pH MEASUREMENT  |
| EMAX-4500-NH3F   | 5      | 8/24/2017      | AMMONIA-N   |
| EMAX-4500-NO2B   | 3      | 4/30/2018      | NITROGEN, NITRITE (SPECTROMETRIC)                     |
| EMAX-4500-NO3E   | 4      | 4/30/2018      | NITROGEN, NITRATE-NITRITE BY COPPER-CADMIUM REDUCTION |
| EMAX-4500-PE     | 5      | 4/30/2018      | PHOSPHORUS (COLORIMETRIC) ALL FORMS                   |
| EMAX-4500-S2D    | 4      | 4/30/2018      | SULFIDE (COLORIMETRY)                                 |
| EMAX-4500-S2F    | 6      | 11/7/2018      | SULFIDE (TITRIMETRIC, IODINE)                         |
| EMAX-4500-S2H    | 3      | 9/25/2017      | CALCULATION OF UN-IONIZED HYDROGEN SULFIDE            |
| EMAX-4500-SIO2C  | 4      | 4/30/2018      | SILICA (COLORIMETRIC)                                 |
| EMAX-4500-TKNC   | 4      | 4/30/2018      | TOTAL KJELDAHL NITROGEN                               |
| EMAX-4500-TKNF   | 1      | 4/30/2018      | TOTAL KJELDAHL NITROGEN                               |

## EMAX ORGANIZATION & MANAGEMENT

### B-2 List of Standard Operating Procedures

---

| EMAX SOP LISTS   |        |                |   |
|------------------|--------|----------------|---|
| ANALYTICAL       |        |                |   |
| STANDARD METHODS |        |                |   |
| SOP #            | Rev. # | Effective Date | TITLE   |
| EMAX-5210B       | 7      | 4/30/2018      | BIOCHEMICAL OXYGEN DEMAND                     |
| EMAX-5220D       | 4      | 9/12/2018      | CHEMICAL OXYGEN DEMAND (COLORIMETRIC, MANUAL) |
| EMAX-5310B       | 4      | 9/18/2017      | TOTAL ORGANIC CARBON                          |
| EMAX-5520B       | 3      | 8/22/2018      | OIL & GREASE (HEM & SGT-HEM)                  |
| EMAX-5540C       | 4      | 4/17/2019      | METHYLENE BLUE ANIONIC SURFACTANTS (MBAS)     |

## EMAX ORGANIZATION & MANAGEMENT

### B-2 List of Standard Operating Procedures

| EMAX SOP LISTS |        |                |  |
|----------------|--------|----------------|--|
| ANALYTICAL     |        |                |  |
| SW846 METHODS  |        |                |  |
| SOP #          | Rev. # | Effective Date | TITLE  |
| EMAX-1010      | 5      | 6/8/2016       | IGNITABILITY   |
| EMAX-1664      | 8      | 9/18/2017      | OIL & GREASE (HEM & SGT-HEM)   |
| EMAX-6010      | 8      | 11/1/2018      | TRACE METALS BY ICP  |
| EMAX-6010C     | 2      | 4/12/2017      | TRACE METALS BY ICP  |
| EMAX-6020      | 10     | 11/15/2018     | TRACE METALS BY ICP-MS   |
| EMAX-6020CA    | 0      | 6/5/2019       | TRACE METALS BY ICP-MS   |
| EMAX-6850      | 2      | 1/18/2019      | PERCHLORATE BY HPLC/MS   |
| EMAX-7196      | 6      | 8/23/2019      | CHROMIUM(VI)   |
| EMAX-7199      | 7      | 7/30/2019      | CHROMIUM(VI)   |
| EMAX-7470      | 8      | 7/13/2016      | MERCURY  |
| EMAX-7471      | 9      | 7/13/2016      | MERCURY  |
| EMAX-8011      | 6      | 6/10/2019      | EDB/DBCP   |
| EMAX-8015D     | 7      | 9/20/2017      | DIESEL RANGE ORGANICS (DRO)  |
| EMAX-8015G     | 5      | 1/24/2014      | GASOLINE RANGE ORGANICS (GRO)  |
| EMAX-8015O     | 1      | 7/20/2018      | ALCOHOLS AND GLYCOLS BY GC   |
| EMAX-8081      | 8      | 6/16/2014      | ORGANOCHLORINE PESTICIDES BY GAS CHROMATOGRAPHY                          |
| EMAX-8082      | 5      | 7/2/2014       | POLYCHLORINATED BIPHENYLS(PCB) AND POLYCHLORINATED TERPHENYLS (PCT) BY G |
| EMAX-8082CON   | 1      | 7/8/2014       | POLYCHLORINATED BIPHENYLS(PCB) CONGENERS BY GAS CHROMATOGRAPHY           |
| EMAX-8141      | 6      | 1/18/2019      | ORGANOPHOSPHORUS COMPOUNDS BY GC   |
| EMAX-8141A     | 0      | 5/6/2019       | ORGANOPHOSPHORUS COMPOUNDS BY GC   |
| EMAX-8151      | 6      | 4/5/2016       | CHLORINATED HERBICIDES   |
| EMAX-8260      | 10     | 6/6/2014       | VOLATILE ORGANIC COMPOUNDS BY GC/MS                                      |
| EMAX-8260C     | 1      | 10/23/2015     | VOLATILE ORGANIC COMPOUNDS BY GC/MS                                      |
| EMAX-8260SIM   | 1      | 9/6/2011       | VOLATILE ORGANIC COMPOUNDS BY GC/MS SIM                                  |
| EMAX-8270      | 6      | 7/10/2014      | SEMIVOLATILE ORGANICS BY GC/MS   |
| EMAX-8270D     | 1      | 7/29/2014      | SEMIVOLATILE ORGANICS BY GC/MS   |
| EMAX-8270SIM   | 2      | 7/5/2011       | SEMIVOLATILE ORGANICS BY GC/MS SIM                                       |

## EMAX ORGANIZATION & MANAGEMENT

### B-2 List of Standard Operating Procedures

| EMAX SOP LISTS |        |                |  |
|----------------|--------|----------------|--|
| ANALYTICAL     |        |                |  |
| SW846 METHODS  |        |                |  |
| SOP #          | Rev. # | Effective Date | TITLE  |
| EMAX-8310      | 7      | 9/20/2017      | POLYNUCLEAR AROMATIC HYDROCARBONS                                |
| EMAX-8330      | 8      | 11/12/2015     | NITROAROMATICS & NITRAMINES BY HPLC                              |
| EMAX-8332      | 3      | 10/29/2015     | NITROGLYCERINE BY HPLC   |
| EMAX-9014      | 8      | 11/29/2016     | CYANIDE, TOTAL   |
| EMAX-9040      | 9      | 9/19/2018      | pH MEASUREMENT   |
| EMAX-9045      | 4      | 6/22/2017      | pH, SOLID AND WASTE SAMPLES                                      |
| EMAX-9050      | 4      | 9/19/2018      | SPECIFIC CONDUCTANCE   |
| EMAX-9056      | 8      | 12/3/2015      | ION CHROMATOGRAPHY ANALYSIS                                      |
| EMAX-9060      | 4      | 10/11/2017     | TOTAL ORGANIC CARBON   |
| EMAX-9065      | 3      | 1/29/2013      | TOTAL PHENOLS BY SPECTROPHOTOMETRY                               |
| EMAX-9070      | 0      | 7/16/2012      | OIL & GREASE (HEM & SGT-HEM)                                     |
| EMAX-9071      | 1      | 9/7/2012       | OIL AND GREASE   |
| EMAX-9095      | 3      | 8/20/2012      | PAINT FILTER LIQUID TEST   |
| EMAX-9253      | 4      | 10/1/2018      | CHLORIDE (TITRIMETRIC SILVER NITRATE)                            |
| EMAX-M8260SIM  | 0      | 3/14/2011      | 1,4-DIOXANE BY GC/MS SIM   |
| EMAX-M8270SIM  | 2      | 10/31/2011     | 1,4-DIOXANE BY GC/MS, MODIFIED METHOD 8270SIM                    |
| EMAX-MCD       | 3      | 9/22/2009      | MOISTURE CONTENT DETERMINATION                                   |
| EMAX-RCN       | 3      | 8/19/2011      | REACTIVE CYANIDE   |
| EMAX-RSE       | 4      | 4/30/2012      | REACTIVE SULFIDE   |
| EMAX-TCPSIM    | 2      | 9/2/2011       | 1,2,3-TRICHLOROPROPANE BY GC/MS SIM                              |
| EMAX-TO15      | 5      | 11/19/2015     | DETERMINATION VOLATILE ORGANIC COMPOUNDS IN AMBIENT AIR BY GC/MS |

## EMAX ORGANIZATION & MANAGEMENT

### B-2 List of Standard Operating Procedures

| EMAX SOP LISTS |        |                |  |
|----------------|--------|----------------|--|
| ANALYTICAL     |        |                |  |
| SPECIAL TEST   |        |                |  |
| SOP #          | Rev. # | Effective Date | TITLE  |
| EMAX-8015AZ    | 3      | 7/20/2018      | AZ C10-C32 HYDROCARBONS IN SOIL                    |
| EMAX-8073      | 1      | 3/17/2015      | AGGRESSIVE INDEX BY CALCULATION                    |
| EMAX-8139      | 0      | 7/5/2011       | CYANURIC ACID BY TURBIDIMETRIC METHOD              |
| EMAX-939M      | 3      | 4/12/2017      | ORGANOLEAD ANALYSIS BY GFAA                        |
| EMAX-AK101     | 2      | 3/8/2013       | AK GASOLINE RANGE ORGANICS                         |
| EMAX-AK102/103 | 4      | 3/30/2017      | AK DIESEL/RESIDUAL RANGE ORGANICS                  |
| EMAX-D1945     | 0      | 3/22/2013      | TEST METHOD FOR NATURAL GASES                      |
| EMAX-RSK175    | 4      | 4/4/2016       | DISSOLVED GASES                                    |
| EMAX-TOCWB     | 3      | 3/30/2017      | TOTAL ORGANIC CARBON (TOC) BY WALKLEY BLACK METHOD |

## EMAX ORGANIZATION & MANAGEMENT

### B-2 List of Standard Operating Procedures

| EMAX SOP LISTS     |        |                |   |
|--------------------|--------|----------------|---|
| SAMPLE PREPARATION |        |                |   |
| SW846 METHODS      |        |                |   |
| SOP #              | Rev. # | Effective Date | TITLE   |
| EMAX-1311          | 3      | 10/30/2015     | TCLP FOR ORGANIC AND INORGANIC ANALYTES           |
| EMAX-1312          | 1      | 9/7/2010       | SYNTHETIC PRECIPITATION LEACHING PROCEDURE (SPLP) |
| EMAX-3010          | 7      | 12/14/2018     | ACID DIGESTION, TOTAL METALS FOR AQUEOUS          |
| EMAX-3050          | 6      | 12/14/2018     | ACID DIGESTION, TOTAL METALS SOLIDS               |
| EMAX-3060          | 1      | 1/22/2015      | ALKALINE DIGESTION FOR HEXAVALENT CHROMIUM        |
| EMAX-3520          | 5      | 3/19/2012      | EXTRACTION, CONTINUOUS LIQUID LIQUID              |
| EMAX-3540          | 3      | 1/18/2019      | EXTRACTION, SOXHLET                               |
| EMAX-3546          | 0      | 8/6/2013       | EXTRACTION, MICROWAVE                             |
| EMAX-3550          | 5      | 5/20/2016      | EXTRACTION, PULSE SONICATION                      |
| EMAX-3580          | 3      | 6/27/2019      | WASTE DILUTION                                    |
| EMAX-3620          | 3      | 11/9/2016      | CLEANUP, FLORISIL                                 |
| EMAX-3640          | 3      | 10/21/2010     | CLEANUP, GEL PERMEATION                           |
| EMAX-3660          | 2      | 10/10/2017     | CLEAN-UP, SULFUR                                  |
| EMAX-3665          | 3      | 10/10/2017     | CLEANUP, SULFURIC ACID/PERMANGANATE               |
| EMAX-5030          | 4      | 9/22/2017      | PURGE & TRAP                                      |
| EMAX-5035          | 4      | 9/22/2017      | CLOSED SYSTEM PURGE & TRAP                        |
| EMAX-WET           | 3      | 10/10/2017     | WASTE EXTRACTION TEST                             |

## EMAX ORGANIZATION & MANAGEMENT

### B-2 List of Standard Operating Procedures

| EMAX SOP LISTS      |        |                |  |
|---------------------|--------|----------------|--|
| DATA MANAGEMENT     |        |                |  |
| QUALITY SYSTEMS     |        |                |  |
| SOP #               | Rev. # | Effective Date | TITLE                                  |
| EMAX-DM01           | 7      | 2/8/2017       | DATA FLOW AND REVIEW                   |
| EMAX-DM02           | 4      | 8/4/2014       | DOCUMENT CONTROL                       |
| EMAX-DM03           | 4      | 11/15/2016     | DATA PACKAGE ASSEMBLY                  |
| EMAX-DM04           | 1      | 11/2/2011      | MANAGEMENT OF LIMS RAW DATA            |
| EMAX-DM05           | 0      | 4/24/2015      | REPORTING PERFORMANCE TEST RESULTS     |
| INFORMATION SYSTEMS |        |                |  |
| QUALITY SYSTEMS     |        |                |  |
| SOP #               | Rev. # | Effective Date | TITLE                                  |
| EMAX-IS01           | 3      | 6/17/2014      | SOFTWARE DOCUMENTATION                 |
| EMAX-IS02           | 2      | 6/17/2014      | SOFTWARE DEVELOPMENT METHODOLOGY       |
| EMAX-IS03           | 2      | 6/17/2014      | SOFTWARE TESTING AND QUALITY ASSURANCE |
| EMAX-IS04           | 3      | 6/17/2014      | SOFTWARE MAINTENANCE                   |
| EMAX-IS05           | 2      | 6/18/2014      | EDD GENERATION AND VALIDATION          |
| EMAX-IS06           | 1      | 3/1/2004       | HISTORICAL FILE MAINTENANCE            |
| EMAX-IS07           | 2      | 3/1/2004       | ACQUISITION OF SOFTWARE PACKAGES       |
| EMAX-IS08           | 5      | 6/24/2014      | DATA SECURITY                          |
| EMAX-IS09           | 3      | 7/15/2010      | BACKING UP FILES                       |
| EMAX-IS10           | 3      | 7/15/2010      | VIRUS PROTECTION                       |
| EMAX-IS11           | 2      | 12/21/2012     | PROJECT SUPPORT FILES                  |
| EMAX-IS12           | 1      | 7/15/2010      | HARDWARE MAINTENANCE                   |
| EMAX-IS13           | 0      | 5/12/2007      | SHUTDOWN AND STARTUP PROCEDURES        |

## EMAX ORGANIZATION & MANAGEMENT

### B-2 List of Standard Operating Procedures

| EMAX SOP LISTS    |        |                |  |
|-------------------|--------|----------------|--|
| QUALITY ASSURANCE |        |                |  |
| QUALITY SYSTEMS   |        |                |  |
| SOP #             | Rev. # | Effective Date | TITLE  |
| EMAX-QA00         | 5      | 10/31/2017     | WRITING STANDARD OPERATING PROCEDURES            |
| EMAX-QA01         | 7      | 1/9/2017       | PROJECT MANAGEMENT                               |
| EMAX-QA02         | 4      | 11/23/2016     | UTILIZATION OF SUBCONTRACT LABORATORIES          |
| EMAX-QA03         | 3      | 3/22/2017      | METHOD DEVELOPMENT                               |
| EMAX-QA04         | 8      | 2/6/2019       | DETECTION LIMIT (DL)                             |
| EMAX-QA05         | 9      | 3/13/2019      | TRAINING   |
| EMAX-QA06         | 6      | 10/10/2017     | CONTROL CHART                                    |
| EMAX-QA07         | 5      | 11/15/2016     | INTERNAL ASSESSMENT                              |
| EMAX-QA08         | 8      | 10/1/2018      | CORRECTIVE ACTION                                |
| EMAX-QA09         | 5      | 11/30/2016     | PURCHASING                                       |
| EMAX-QA10         | 4      | 9/22/2017      | ETHICS PROGRAM                                   |
| QUALITY CONTROL   |        |                |  |
| QUALITY SYSTEMS   |        |                |  |
| SOP #             | Rev. # | Effective Date | TITLE  |
| EMAX-QC01         | 4      | 2/15/2017      | QUALITY CONTROL FOR CHEMICALS                    |
| EMAX-QC02         | 2      | 8/16/2010      | ANALYTICAL STANDARD PREPARATION                  |
| EMAX-QC03         | 4      | 10/31/2017     | REFRIGERATOR CONTROL                             |
| EMAX-QC04         | 6      | 1/9/2017       | BALANCE CALIBRATION                              |
| EMAX-QC05         | 6      | 10/10/2017     | CALIBRATION OF THERMOMETERS                      |
| EMAX-QC06         | 6      | 10/15/2015     | VOLUMETRIC LABWARE AND MICROPIPETTE VERIFICATION |
| EMAX-QC07         | 3      | 2/6/2019       | LABWARE CLEANING                                 |
| EMAX-QC08         | 1      | 7/15/2010      | HANDLING HIGHLY CONTAMINATED SAMPLES             |
| EMAX-QC09         | 2      | 8/16/2010      | FUME HOOD INSPECTION PROGRAM                     |



## EMAX ORGANIZATION & MANAGEMENT

### B-2 List of Standard Operating Procedures

| EMAX SOP LISTS    |        |                |  |
|-------------------|--------|----------------|--|
| RADIATION SAFETY  |        |                |  |
| QUALITY SYSTEMS   |        |                |  |
| SOP #             | Rev. # | Effective Date | TITLE  |
| EMAX-RS01         | 5      | 12/12/2011     | SURVEY METER USE   |
| EMAX-RS02         | 3      | 12/12/2011     | RECEIVING RADIOACTIVE MATERIALS                              |
| EMAX-RS03         | 6      | 12/12/2011     | CONTROL OF RADIOACTIVE SAMPLES                               |
| EMAX-RS04         | 3      | 12/12/2011     | EMERGENCY RESPONSE & DECONTAMINATION OF RADIOACTIVE MATERIAL |
| EMAX-RS05         | 4      | 12/12/2011     | RADIOLOGICAL WORKER PERSONNEL MONITORING                     |
| EMAX-RS06         | 4      | 12/12/2011     | FACILITY MONITORING PROGRAM                                  |
| EMAX-RS07         | 2      | 12/12/2011     | RADIATION SAFETY INTERNAL AUDIT                              |
| SAMPLE MANAGEMENT |        |                |  |
| QUALITY SYSTEMS   |        |                |  |
| SOP #             | Rev. # | Effective Date | TITLE  |
| EMAX-SM01         | 8      | 6/15/2018      | SAMPLE MANAGEMENT  |
| EMAX-SM02         | 11     | 8/8/2019       | SAMPLE RECEIVING   |
| EMAX-SM03         | 6      | 3/20/2017      | WASTE DISPOSAL   |
| EMAX-SM04         | 1      | 5/11/2012      | ANALYTICAL AND QC SAMPLE LABELING                            |
| EMAX-SM05         | 4      | 4/22/2015      | SAMPLE CONTAINERS, HANDLING AND SHIPPING                     |
| EMAX-SM06         | 2      | 5/1/2012       | TRIP BLANK PREPARATION                                       |
| EMAX-SM07         | 1      | 6/15/2012      | OVERSEAS QUARANTINED SOILS                                   |

**EMAX ORGANIZATION & MANAGEMENT**  
**B-3 List of Major Equipment**



**LIST OF MAJOR ANALYTICAL EQUIPMENT**

| No. | Type | Detector | Use          | Manufacturer    | Model         | Location  | Date Acquired |
|-----|------|----------|--------------|-----------------|---------------|-----------|---------------|
| 1   | GC   | MS       | 524 624 8260 | Hewlett Packard | 5890/5970     | VOLATILES | 6/1/1996      |
| 2   | GC   | MS       | 524 624 8260 | Hewlett Packard | 5890/5970     | VOLATILES | 6/1/1996      |
| 3   | GC   | MS       | 524 624 8260 | Hewlett Packard | 5890/5870     | VOLATILES | 6/1/1996      |
| 5   | GC   | MS       | 524 624 8260 | Hewlett Packard | 5890/5870     | VOLATILES | 6/1/1996      |
| 6   | GC   | MS       | 524 624 8260 | Hewlett Packard | 5890/5870     | VOLATILES | 6/1/1996      |
| 67  | GC   | MS       | 524 624 8260 | Hewlett Packard | 5890 II/5971B | VOLATILES | 9/1/2001      |
| 83  | GC   | MS       | TO15         | VARIAN          | SATURN 2000   | VOLATILES | 9/25/2002     |
| 94  | GC   | MS       | 524 624 8260 | Hewlett Packard | 5890A         | VOLATILES | 3/24/2003     |
| 111 | GC   | MS       | 524 624 8260 | Agilent         | 7890A/G3171A  | VOLATILES | 2/26/2008     |
| 124 | GC   | MS       | 524 624 8260 | Hewlett Packard | 5890 SII      | VOLATILES | 9/21/2010     |
| 125 | GC   | MS       | 524 624 8260 | Agilent         | 7890A/5975C   | VOLATILES | 12/17/2010    |
| 126 | GC   | MS       | 524 624 8260 | Agilent         | 6890N/5973    | VOLATILES | 1/4/2011      |

**EMAX ORGANIZATION & MANAGEMENT**  
**B-3 List of Major Equipment**



**LIST OF MAJOR ANALYTICAL EQUIPMENT**

| No. | Type | Detector | Use           | Manufacturer    | Model           | Location      | Date Acquired |
|-----|------|----------|---------------|-----------------|-----------------|---------------|---------------|
| 8   | GC   | Dual ECD | 8081 8082     | Hewlett Packard | 5891 II         | SEMIVOLATILES | 6/1/1996      |
| 9   | GC   | Dual ECD | 8151          | Hewlett Packard | 5892 II         | SEMIVOLATILES | 6/1/1996      |
| 12  | GC   | Dual FPD | 8141          | Hewlett Packard | 5890            | SEMIVOLATILES | 6/1/1996      |
| 16  | GC   | Dual ECD | 8081 8082     | Hewlett Packard | 5890            | SEMIVOLATILES | 6/1/1996      |
| 71  | GC   | Dual ECD | 8082          | Hewlett Packard | 5890 II         | SEMIVOLATILES | 12/18/2001    |
| 113 | GC   | MS       | 625 8270      | Agilent         | 7890A/G3440A    | SEMIVOLATILES | 9/11/2008     |
| 116 | GC   | MS       | 625 8270      | Agilent         | 7890A-5975C MSD | SEMIVOLATILES | 6/5/2009      |
| 117 | GC   | Dual ECD | 8081 8082     | Perkin Elmer    | Clarus 600GC    | SEMIVOLATILES | 1/22/2010     |
| 118 | GC   | MS       | 625 8270      | Thermo Fisher   | Trace DSQII MS  | SEMIVOLATILES | 3/1/2010      |
| 119 | GC   | MS       | 625 8270      | Thermo Fisher   | Trace DSQII MS  | SEMIVOLATILES | 3/1/2010      |
| 130 | GC   | Dual ECD | 8081 8082 608 | Perkin Elmer    | PE Clarus 680   | SEMIVOLATILES | 12/15/2011    |

## EMAX ORGANIZATION & MANAGEMENT

### B-3 List of Major Equipment



### LIST OF MAJOR ANALYTICAL EQUIPMENT

| No. | Type | Detector            | Use                | Manufacturer        | Model                          | Location              | Date Acquired |
|-----|------|---------------------|--------------------|---------------------|--------------------------------|-----------------------|---------------|
| 13  | GC   | TCD/FID             | CO2                | Hewlett Packard     | 5890                           | HPLC, FUELS, IC & TOC | 6/1/1996      |
| 39  | GC   | FID/PID             | 8015 (Purgeables)  | Hewlett Packard     | 5890                           | HPLC, FUELS, IC & TOC | 6/1/1996      |
| 50  | GC   | FID                 | RSK175 / Glycol    | Hewlett Packard     | 5890                           | HPLC, FUELS, IC & TOC | 6/1/1996      |
| 55  | GC   | FID                 | 8015 (Purgeables)  | Hewlett Packard     | 5890                           | HPLC, FUELS, IC & TOC | 8/1/2000      |
| 57  | IC   | Conductivity        | 314.0 300.0M       | Dionex              | LC25                           | HPLC, FUELS, IC & TOC | 9/28/2000     |
| 59  | IC   | UV/VIS              | 218.6/7199         | Dionex              | LC20                           | HPLC, FUELS, IC & TOC | 6/1/1996      |
| 72  | GC   | FID                 | 8015 (Alcohols)    | Hewlett Packard     | 5890 II                        | HPLC, FUELS, IC & TOC | 12/18/2001    |
| 81  | HPLC | UV                  | 8310 8330          | Waters              | 717 Plus                       | HPLC, FUELS, IC & TOC | 6/7/2002      |
| 100 | IC   | Conductivity/UV/VIS | 300.0              | Metrohm             | 761 Compact IC                 | HPLC, FUELS, IC & TOC | 4/11/2005     |
| 105 | GC   | FID                 | 8015 (Extractable) | Agilent             | G1530N,G1540N                  | HPLC, FUELS, IC & TOC | 4/5/2006      |
| 106 | IC   | Conductivity/UV/VIS | 300.0M             | Dionex              | ICS-1000 with AS50 Autosampler | HPLC, FUELS, IC & TOC | 5/8/2006      |
| 107 | IC   | Conductivity        | 300.0              | Metrohm             | 800 Series                     | HPLC, FUELS, IC & TOC | 10/4/2006     |
| 112 | IC   | Conductivity        | 300.0              | Metrohm             | 881IC PRO                      | HPLC, FUELS, IC & TOC | 6/2/2008      |
| 115 | HPLC | UV/PDA              | 8330               | ThermoFisher        | 60057-60002                    | HPLC, FUELS, IC & TOC | 5/27/2009     |
| 121 | GC   | FID                 | 8015 (Extractable) | Perkin Elmer        | Clarus 680                     | HPLC, FUELS, IC & TOC | 8/9/2010      |
| 131 | HPLC | MSQ                 | 6850               | Dionex/ThermoFisher | LPG-3400SD                     | HPLC, FUELS, IC & TOC | 1/10/2012     |
| 133 | IC   | UV VIS              | 218.6 7199         | Metrohm             | 887                            | HPLC, FUELS, IC & TOC | 5/14/2012     |
| 149 | GC   | FID                 | 8015 (Purgeables)  | Hewlett Packard     | 5890                           | HPLC, FUELS, IC & TOC | 8/12/2019     |

## EMAX ORGANIZATION & MANAGEMENT

### B-3 List of Major Equipment



### LIST OF MAJOR ANALYTICAL EQUIPMENT

| No. | Type             | Detector   | Use                   | Manufacturer    | Model              | Location | Date Acquired |
|-----|------------------|------------|-----------------------|-----------------|--------------------|----------|---------------|
| 20  | GFAA             | GFAA       | Organo Lead           | Varian          | Zeeman SpectAA 400 | METALS   | 6/1/1996      |
| 47  | Mercury Analyzer | Cold Vapor | Mercury by Cold Vapor | Leeman PS-200II | 200II              | METALS   | 10/26/1999    |
| 74  | Mercury Analyzer | Cold Vapor | Mercury by Cold Vapor | Leeman PS       | HYDRA-AA           | METALS   | 12/1/2001     |
| 98  | ICP              | MS         | Metals by ICP-MS      | Agilent         | 7500               | METALS   | 9/15/2003     |
| 108 | ICP              | AES        | Metals by ICP         | Thermo          | ICAP 6500          | METALS   | 12/1/2006     |
| 127 | ICP              | MS         | Metals by ICP-MS      | Agilent         | 7500 CX            | METALS   | 1/7/2011      |
| 148 | ICP              | MS         | Metals by ICP-MS      | Agilent         | 7800               | METALS   | 8/1/2019      |



### LIST OF MAJOR ANALYTICAL EQUIPMENT

| No. | Type               | Detector               | Use                   | Manufacturer      | Model          | Location          | Date Acquired |
|-----|--------------------|------------------------|-----------------------|-------------------|----------------|-------------------|---------------|
| 28  | Flash Point        | Thermometer            | Ignitability          | Pensky Martens    | Semi-Automatic | GENERAL CHEMISTRY | 6/1/1996      |
| 53  | pH Meter           | pH Probe               | pH                    | Orion             | 420A           | GENERAL CHEMISTRY | 4/1/2000      |
| 70  | Spectrometer       | Photodiode             | Spectrometric Methods | Thermo Spectronic | Spectronic 20D | GENERAL CHEMISTRY | 12/1/2001     |
| 104 | Conductivity Meter | Platinum               | Specific Conductance  | TRACEABLE         | 61161          | GENERAL CHEMISTRY | 1/2/2006      |
| 109 | BOD Probe          | Dissolved Oxygen Probe | BOD-5day              |                   |                | GENERAL CHEMISTRY |               |
| 110 | Turbidimeter       | Turbidimeter           | Turbidimetric         | HF INDUSTRIES     | HF-MICRO 100   | GENERAL CHEMISTRY | 8/1/2007      |
| 114 | PC-Titrate         | pH Probe               | Alkalinity            | MAN-TECH          | PC-1300-475    | GENERAL CHEMISTRY | 10/1/2008     |
| 128 | pH Meter           | pH Probe SN 35805-10   | pH 7199               | Oakton            | pH 510         | GENERAL CHEMISTRY | 1/1/2009      |

## EMAX ORGANIZATION & MANAGEMENT

### B-4 Accreditations



---

| <b>FEDERAL GOVERNMENT VALIDATIONS</b>  |
|--|
| DEPARTMENT OF DEFENSE, ELAP  |
| CALIFORNIA RADIOACTIVE MATERIAL LICENSE                                      |
| DEPARTMENT OF FOOD AND AGRICULTURE,<br>PERMIT TO RECEIVE SOILS FROM OVERSEAS |

| <b>STATE CERTIFICATIONS</b> |
|-----------------------------|
| ALASKA                      |
| ARIZONA                     |
| CALIFORNIA                  |
| HAWAII                      |
| KANSAS                      |
| MARYLAND                    |
| NEVADA                      |
| NEW HAMPSHIRE               |
| OKLAHOMA                    |
| UTAH                        |
| WASHINGTON                  |

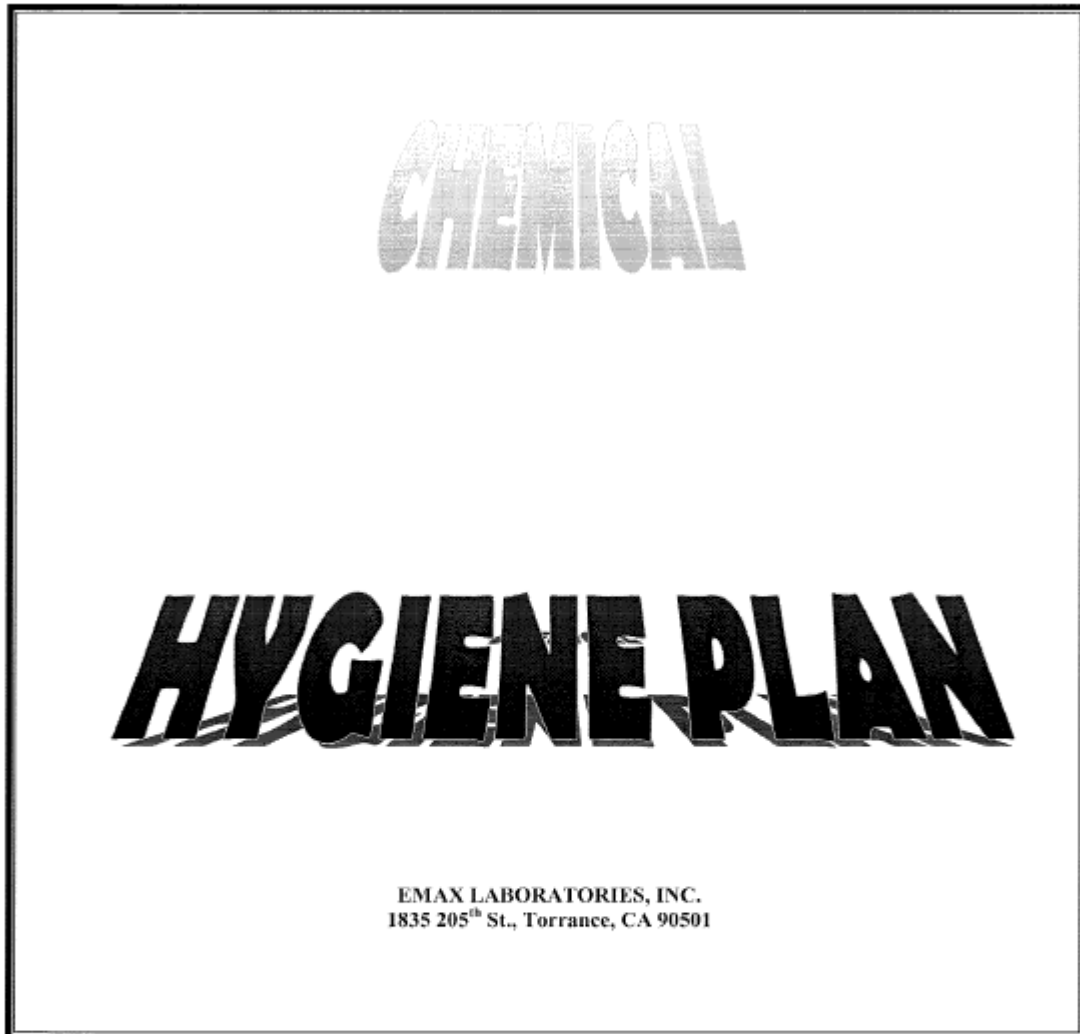
**EMAX ORGANIZATION & MANAGEMENT**  
**B-5 Health & Safety Practices**

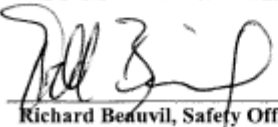

|             |   |           |
|-------------|---|-----------|
| Approved By |  | 8/26/19   |
|             | Richard Beauvil, Safety Officer   | Date      |
| Approved By |  | 8/26/2019 |
|             | Caspar Pang, President  | Date      |

|               |              |
|---------------|--------------|
| Document ID   | EMAX-CHP-08  |
| Revision No.  | 8            |
| Date Released | 08/26/19     |
| Issue No.     | EMAX-CHP-08- |
| Issued To     |              |

**EMAX ORGANIZATION & MANAGEMENT**  
**B-5 Health & Safety Practices**

---

## CHEMICAL HYGIENE PLAN

### Table of Contents

|  | <b>Pages</b> |
|--|--------------|
| <b>1.0 Introduction .....</b>                                      | <b>4</b>     |
| 1.1 Objective .....  | 4            |
| 1.2 Responsibility .....   | 4            |
| <b>2.0 Control Measures .....</b>                                  | <b>5</b>     |
| 2.1 Prior Approval of Hazardous Chemicals .....                    | 5            |
| 2.1.1 Select Cancer Causing Agents .....                           | 5            |
| 2.1.1.1 Regulated as a Carcinogen by OSHA .....                    | 5            |
| 2.1.1.2 National Toxicology Program (NTP) Carcinogenic List .....  | 5            |
| 2.1.1.3 World Health Organization Carcinogenic Agents .....        | 5            |
| 2.1.1.4 State of California Reproductive Toxin Chemical List ..... | 5            |
| <b>3.0 Standard Operating Procedures .....</b>                     | <b>6</b>     |
| 3.1 Chemicals .....  | 6            |
| 3.1.1 General Rule .....   | 6            |
| 3.1.2 Acids and Bases .....  | 6            |
| 3.1.3 Flammable Liquids .....                                      | 7            |
| 3.1.4 Toxic Materials .....  | 7            |
| 3.1.5 Personal Protective Equipment .....                          | 7            |
| 3.1.5.1 Glove Awareness Policy .....                               | 8            |
| 3.2 Compressed Gas Cylinders .....                                 | 10           |
| 3.2.1 General .....  | 10           |
| 3.2.2 Inspection .....   | 10           |
| 3.2.3 Storage/Transport/Use .....                                  | 11           |
| 3.3 Specific Gases .....   | 11           |
| 3.3.1 Argon .....  | 11           |
| 3.3.2 Liquid Argon .....   | 12           |
| 3.3.3 Helium .....   | 13           |
| 3.3.4 Nitrogen .....   | 14           |
| 3.3.5 Liquid Nitrogen .....  | 14           |
| 3.3.6 Hydrogen .....   | 15           |
| 3.4 Incompatible Materials in the Laboratory .....                 | 15           |
| 3.5 Chemical Spills .....  | 16           |



## EMAX ORGANIZATION & MANAGEMENT

### B-5 Health & Safety Practices

|  | <b>Pages</b> |
|--|--------------|
| 3.6 Disposal Procedures for Chemical Wastes .....                      | 17           |
| 3.7 Potentially Explosive Chemicals (including organic peroxide) ..... | 18           |
| 3.8 Methylene Chloride Exposure Monitoring .....                       | 19           |
| <b>4.0 Protective Equipment Evaluation .....</b>                       | <b>20</b>    |
| 4.1 Procedures for Checking Safety Showers/Eye Wash .....              | 20           |
| 4.1.1 Safety Showers .....   | 20           |
| 4.1.2 Eye Wash .....   | 21           |
| 4.2 Instruction for Replacing Portable Emergency Eye Washes .....      | 21           |
| 4.3 Local Exhaust Systems .....  | 21           |
| 4.3.1 Baseline Evaluation .....  | 22           |
| 4.3.1.1 Airflow Measurements of Hoods .....                            | 22           |
| 4.4 Respiratory Protection Program .....                               | 22           |
| 4.4.1 Policy Statement .....   | 22           |
| 4.4.2 Responsibilities .....   | 22           |
| 4.4.2.1 Chemical Hygiene Officer .....                                 | 22           |
| 4.4.2.2 Divisional/Departmental Safety Representatives .....           | 22           |
| 4.4.2.3 Employees .....  | 23           |
| 4.4.3 Respirator Selection .....                                       | 23           |
| 4.4.4 Training and Education .....                                     | 23           |
| 4.5 Program Evaluation .....   | 24           |
| 4.6 Respiratory Protective Equipment: Use and Limitations .....        | 24           |
| 4.6.1 Air Purifying Respirators .....                                  | 24           |
| 4.6.2 Chemical Cartridges Respirators Limitations .....                | 24           |
| 4.7 Respirator Physical Evaluation Form .....                          | 26           |
| 4.8 Medical Summary Form .....   | 27           |
| <b>5.0 Employee Information and Training .....</b>                     | <b>28</b>    |
| 5.1 Employee Information .....   | 28           |
| 5.2 Employee Training .....  | 28           |
| 5.2.1 Training Statement .....   | 28           |
| 5.2.2 Safety Data Sheets .....   | 28           |
| 5.2.3 Labeling Policy .....  | 29           |
| 5.2.4 Hazard Determination .....                                       | 30           |
| 5.2.5 Employee Training .....  | 30           |

## EMAX ORGANIZATION & MANAGEMENT

### B-5 Health & Safety Practices

---

|  | <b>Pages</b> |
|--|--------------|
| 5.2.6 Execution/Assigned Responsibilities .....                | 31           |
| 5.2.6.1 Purchasing Section .....                               | 31           |
| 5.2.6.2 Departmental Safety Representatives .....              | 31           |
| 5.2.6.3 Personnel Section .....                                | 31           |
| 5.2.6.4 Chemical Hygiene Officer .....                         | 31           |
| 5.2.7 Fire Extinguisher Training .....                         | 32           |
| 5.2.7.1 Portable Fire Extinguishers .....                      | 32           |
| 5.2.8 First Aid/CPR Training .....                             | 32           |
| 5.2.8.1 Mandatory Training .....                               | 32           |
| 5.2.8.2 29 CFR 1910.151 .....                                  | 32           |
| 5.2.8.3 Voluntary .....  | 33           |
| <b>6.0 Medical Consultation and Medical Examinations .....</b> | <b>33</b>    |
| 6.1 Medical Examinations .....                                 | 33           |
| 6.2 Medical Consultation .....                                 | 33           |
| 6.3 Information Provided to the Physician .....                | 33           |
| 6.4 Physician Written Opinion .....                            | 33           |
| 6.5 Record Keeping .....                                       | 34           |

## **EMAX ORGANIZATION & MANAGEMENT**

### **B-5 Health & Safety Practices**

---

#### **1.0 INTRODUCTION**

##### **1.1 Objective**

The objective of this plan is to set forth procedure for equipment handling, personal protective equipment and work practice to protect employees from the health hazards presented by hazardous chemicals used in the laboratory and to meet the requirements set forth in Section E, Federal Register 29 Part 1910 for Occupational Safety and Standards.

##### **1.2 Responsibility**

The Chemical Hygiene Plan is designed as a tool to coordinate safety procedures at EMAX. Responsibility for chemical hygiene rests at all levels including the Chief Executive Officer who is ultimately responsible for it. Therefore, it is essential that he/she must provide continuing support for the plan.

The management must designate a Chemical Hygiene Officer who is qualified to by training or experience to provide technical guidance in the development and implementation of the provisions of the Chemical Hygiene Plan. To maintain manufacturers Safety Data Sheet to determine appropriate practice and equipment requirements. To monitor proper functioning and inspection of protective and emergency equipment and arrange for prompt repairs as needed.

Laboratory supervisors must ensure that workers understand and practice the chemical hygiene rules. Protective equipment should be made available and kept in good working order. However, individual laboratory worker must develop good personal hygiene habits and make proper use of the protective equipment. Thus, all employees must cooperate in complying with the provisions of the chemical hygiene plan.

Disciplinary action may be taken when personnel do not adhere to the Chemical Hygiene Plan. The employee will be given an initial verbal warning. Further incidents will warrant a written warning placed in the employee's personnel file. Repeated and habitual offenses will be subject to dismissal.

## **EMAX ORGANIZATION & MANAGEMENT**

### **B-5 Health & Safety Practices**

---

#### **2.0 CONTROL MEASURES**

Professional judgment is used in determining the degree of control measure required for specific contaminants. Annually, a walk through survey should be conducted by an industrial hygienist. Additional air sampling or increased ventilation if required will be conducted. Individual issues addressed at the safety meeting will be evaluated and corrective actions be taken.

##### **2.1 Prior Approval of Hazardous Chemicals**

Additional preventive measures may be required to protect employees working with particularly hazardous chemicals such as select carcinogens, reproductive toxins and chemicals producing a high degree of toxicity.

Specific control measures to be taken later will be based on the degree of toxicity, the potential of exposure in a particular procedure and the capacity of the engineering controls administrative practices or protective equipment to control exposures effectively.

One area of potential chemical exposure at EMAX is the organic prep area. Methylene Chloride is the primary chemical solvent used for most of the extraction methods. Exposure level of Methylene Chloride in the organic prep working area is monitored annually. See section 3.8 under Standard Operating Procedure.

##### **2.1.1 Select Cancer Causing Agents**

Substances proven to be carcinogenic to humans or demonstrating high carcinogenic potency to animals should be controlled extremely well. Four categories of carcinogens are addressed.

###### **2.1.1.1 Substances regulated as a Carcinogen by OSHA**

Chemical regulated as carcinogens by OSHA can be found in 29 CFR part 1910.

###### **2.1.1.2 National Toxicology Program (NTP) Carcinogen List.**

Chemicals listed as "known to be carcinogens" in the Annual Report on Carcinogens published by the National Toxicology program (NTP)

###### **2.1.1.3 World Health Organization Carcinogenic Agents**

Carcinogenic agent listed under group 1 "carcinogenic to humans" by the International Agency for Research on Cancer Monographs (IARC)

###### **2.1.1.4 State of California Reproductive Toxin Chemical List**

Chemicals listed on the State of California Safe Drinking Water and Toxic Enforcement Act of 1986 (Proposition 65) as chemicals known to cause reproductive toxicity as of 1990.

## EMAX ORGANIZATION & MANAGEMENT

### B-5 Health & Safety Practices

---

#### 3.0 STANDARD OPERATING PROCEDURES

Standard operating procedures should be familiar to all employees.

When working with hazardous materials, it is essential to know about their physical properties and their potential health effects.

#### 3.1 Chemicals

The term chemicals, as used in this policy, refers to hazardous substances, samples, and hazardous wastes.

##### 3.1.1 General Rule

- Awareness is the most fundamental rule of chemical safety.
- Use common sense when working with or around any area where chemicals are being stored.
- The chemicals hazards are determined from the SDS (Safety Data Sheet) but also are now visibly displayed on the label of that any particular chemical following the globally harmonized system.

##### 3.1.2 Acids and Bases

- General Information
- Corrosive: pH greater than 12 or less than 2.
- Corrosive chemicals will irritate or burn the skin, eyes, and respiratory tract. Severe exposure can cause permanent damage.
- Proper Handling, Use and Storage Procedures
- Add acid or base to water (A to W) never vice versa
- Always pour acid slowly to avoid splashing or superheating.
- Always make sure there is a source of water in the area when working with corrosive chemicals, in case of an emergency.
- Always flush the outside of acid or base containers with water after using.
- After using acids or bases, wipe the surface area you used it on. This will get rid of splatters and spills that may not otherwise be visible.
- All bases or base solutions should be stored in plastic. Do **not** use glass.
- All acids or acid solutions should be stored in glass. Do not use plastic.



## EMAX ORGANIZATION & MANAGEMENT

### B-5 Health & Safety Practices

---

- Store acids and bases separately and keep both away from flammables.

#### 3.1.3 Flammable Liquids

Whenever flammable vapors are present there is both fire and an explosion hazard. It is important to understand that it is the vapor, not the liquid that can burn. Flash point is the temperature at which enough vapor is given off to form an ignitable mixture with air. Chemicals with a flash point of less than 100°F are classified as flammable.

You must be aware of the hazards of flammable liquids and you must take positive measures to eliminate the risk of injury. Flammable liquids can be managed safely if they are stored, handled, mixed and poured according to the following safety procedures.

#### 3.1.4 Toxic Materials

A toxic chemical has four (4) routes of entry into the body:

1. Inhalation
2. Ingestion
3. injection
4. Eye or skin contact

You can protect yourselves by using the proper Personal Protective Equipment (PPE).

#### 3.1.5 Personal Protective Equipment

Proper protective equipment shall be provided, used and maintained in a sanitary and reliable condition where there is a chemical hazard that may cause illness or injury to the employees.

- Safety glasses must be worn at all times as prescribed by the procedures of the activity being performed. ANYONE entering a designated laboratory area must wear safety glasses.
- Face shield or splash goggles must be worn when any SIGNIFICANT SPLASH HAZARD exists. (To be determined by supervisors or from past experience with splash-type accidents).
- Contact lenses, which are an additional potential hazard when working in a building where there are samples, acids, fuming agents, solvents, etc., **must not be worn** at any time by employees.
- Lab coats provide a good first level of skin protection against chemical splashes as well as protective clothing, and should be worn during all lab activities. Lab coats are not to be worn in the lunchroom, restrooms or front offices.

## EMAX ORGANIZATION & MANAGEMENT

### B-5 Health & Safety Practices

---

- Respirators-Respirators must be worn if there is a potential for exposure to air contaminants in excess of the allowable limits or if the individual is experiencing any symptoms such as headaches or irritation.
- Shoes – A closed-toe shoe is the only footwear allowed in the laboratory area.
- Sample handling-When handling unknown samples, gloves must be worn. (See glove awareness policy section 3.1.5.1)
- Corrosives - Chemical-resistant gloves must be worn. If there is a splash potential, chemical goggles and/or face shield and additional protective clothing should be worn depending on the extent of possible exposure.
- Solvents - Wear chemical-resistant gloves to prevent prolonged or repeated skin contact, such as submerging hands in solvent or handling solvent-soaked rags. If there is a splash potential, chemical goggles and/or face shield and additional protective clothing should be worn, depending on the extent of possible exposure.

#### 3.1.5.1 Glove Awareness Policy

##### Sample Receiving:

1. Gloves must be worn when coolers are received and placed under the hood to check for broken sample containers.
2. Remove Ziploc bag containing the Chain of Custody from the cooler.
3. Chain of custody must be removed from the bag by someone else without gloves. (COC may be removed also by using a Kim wipe or paper towel).
4. Remove gloves to make a work copy to write all discrepancies or have another person make the copy.
5. Using gloves move cooler (s) inside sample receiving area and remove sample containers from the coolers.
6. Place every container in an orderly fashion to match the label IDs to the chain of custody later.
7. Tag the sample containers. Check tagging, label IDs, and chain of custody information are all matching.
8. Check the pH on all containers and write any discrepancies on work COC.
9. Check for discrepancies on work COC and fill out SRF1 and SRF2. (Preferably another sample receiving personnel should perform this function).
10. Once the SRFs are filled out, finish paperwork in the office area.
11. Using gloves place all sample containers in storage.

## EMAX ORGANIZATION & MANAGEMENT

### B-5 Health & Safety Practices

---

#### Sample Weighing:

1. When weighing samples, samples must be handled with gloves.
2. Write the sequence and/or sample IDs in the run log or prep log ahead of time.
3. When reading sample weight protect the logbook with transparency film specially designed for logging sample weight so that your gloves do not touch the logbook.
4. Use the pencils provided at weighing area attached by a fixed string. Only the tip of the pencil should be touching the logbook. If you are using your own pen, handle the pen without gloves.

#### Sample Preparation:

1. Handle logbooks without gloves. Write the sequence and/or sample IDs on logbook ahead of time; otherwise protect the logbook from touching the gloves.
2. Wear gloves to remove samples from the storage area.
3. Wear gloves when weighing soil samples. (Follow procedure for sample weighing above).
4. If gloves appear dirty or contaminated, discard and use new gloves. Use a Kim wipe or paper towels to open doors and proceed to the prep area.
5. Continue wearing gloves to finish the extraction process. If methylene chloride is to be used wear appropriate gloves for the procedure.
6. Remove gloves when performing administrative tasks or have another technician write in the logbook. (i.e. spiking).

#### Sample Analysis:

1. Use gloves when handling samples, extracts or preparing standards.
2. Write the run log sequence and/or sample IDs on logbook ahead of time; otherwise protect the logbook from touching the gloves.
3. Remove gloves when performing any administrative tasks. (Writing in logbooks or using the computer keyboard).

#### Sample disposal:

1. Wear gloves when handling satellite waste or sample disposal.
2. Put satellite waste on a cart and move the waste to the 90 day storage area.
3. Use kimwipe or paper towels to open doors.



## EMAX ORGANIZATION & MANAGEMENT

### B-5 Health & Safety Practices

---

4. If during the waste disposal process, gloves become dirty and/or contaminated discard them and use a new pair of gloves.
5. Dispose satellite waste or samples in appropriate 55 gallon drums.
6. Before leaving the 90 day storage area, remove gloves. Log in the waste in the logbook.
7. Put new gloves on and lock the 90 day storage area.
8. Return empty satellite containers to the lab. Use kim wipes or paper towels to open doors.
9. Discard gloves and wash your hands.

**Note:** If gloves appear to be dirty or contaminated, replace them to keep the level of contamination low. Do not touch door with gloves. Remove gloves or use a paper towel to open doors. Dispose paper towel in waste bin.

### 3.2. COMPRESSED GAS CYLINDERS

#### 3.2.1 General

- Be extremely careful when handling compressed gas cylinders. Do not drop or expose them to extreme temperatures.
- Except when in use, the valve cap or valve protection device must be always in place.
- Be sure all cylinder valves are closed before moving them, when work is finished, and when the cylinder is empty.
- Never use the valve or valve cap to lift or move cylinders. Always use a hand truck for support. Chain cylinder to the hand truck. Never roll cylinders.
- Improperly fitting connections on cylinders should never be forced. Never tamper with safety devices of cylinder valves. Always use proper fitting on gauges suitable for the particular gas being used.
- Contents must be properly marked on all cylinders. Color coding is not a standardized means for identification.
- Never mix gases in a cylinder. Explosion, contamination, corrosion, and other hazards can result.
- Cylinder valves must not be tampered with nor should any attempt be made to repair them. If you experience trouble, the supplier should be notified promptly, indicating the type of trouble and the cylinder's serial number.

#### 3.2.2 Inspection

## EMAX ORGANIZATION & MANAGEMENT

### B-5 Health & Safety Practices

---

- Cylinder should be checked periodically for rust, dents, or leaks, particularly around the neck of the cylinder (including the screw threads) and at the bottom.
- When there is doubt about a cylinder's structural strength or the possibility of leakage notify the supplier immediately.
- Safety valves, gauges, and regulators should be securely mounted and may not be used if they are bent or damaged by exposure to weather or by mishandling.
- The Department of Transportation requires that all cylinders be tested for strength and integrity on a periodic basis. Last testing date is stamped on each cylinder along with symbols indicating date cylinder is due to be re-tested. If you have any questions, contact the Safety Officer or Supplier.

#### 3.2.3 Storage/Transport/Use

- Always store and use compressed gas cylinders (whether full or empty) in an upright position. Chain or otherwise secure them so they cannot be upset, fall or strike each other.
- Storage temperature should be regulated, so as not to exceed 100°F.
- All valves should be closed when not in actual use.
- Use proper regulator for the particular gas.
- Carefully and slowly open valves and adjust gas flow rates.
- Always consider cylinders to be full and handle accordingly.
- All empty cylinders must be marked "EMPTY". They must be separated from the full cylinders and promptly returned to the storage area with the valve protection caps in place. All valves must be closed.
- Discontinue using a high-pressure cylinder when the pressure reaches 500 psig, and clearly marked EMPTY; then remove for return to vendor.
- Cylinders must never be placed where they might become part of an electrical circuit.
- Always make sure to protect cylinders from sparks, flames, and contact with energized electrical equipment.
- Always store flammable gas cylinders in properly designated and safeguarded areas only.

## EMAX ORGANIZATION & MANAGEMENT

### B-5 Health & Safety Practices

---

#### 3.3 Specific Gases

##### 3.3.1 Argon

- Argon is the most abundant member of the rare gas family, which consists of helium, neon, argon, krypton, and xenon. All of these gases are monatomic and are characterized by their extreme chemical inactivity. Argon is colorless, odorless, and tasteless gas somewhat soluble in water (4 volumes in 100). It is normally supplied as a non-liquified gas compressed into cylinders at a pressure of approximately 200 p.s.i.g at 70°F.
- Argon is nontoxic but can act as a simple asphyxiant by displacing the necessary amount of air to support life.
- Leaks of argon in lines and equipment setups may be detected by painting the suspected sites with water, leaks will be evident by bubble formation.
- Since argon is inert, no special materials of construction are required. However, any piping or vessels containing argon should be adequately designed to have a working pressure as specified by competent engineers, using a safety factor conforming to the A.S.M.E. (American Society of Mechanical engineers) code for pressure piping.
- Cylinders containing argon have safety devices of either the frangible disc type or frangible disc backed up with fusible metal melting at approximately 212 ° F. Cylinders pressurized 10% in excess of their marked service pressure in accordance with present D.O.T. (Department of Transportation) regulations must contain only safety devices are usually frangible disc type. These safety devices are usually an integral part of the cylinder valve, situated opposite the valve outlet.
- Argon is shipped in high pressure steel cylinders as non-flammable, compressed gas, taking a D.O.T. "Green Label". They are usually filled to the marked service pressure of the cylinder or to a maximum of 10% excess of the marked service pressure in accordance with present D.O.T. regulations.
- Argon is monatomic, chemically inactive gas. It will not react with other elements or compounds. While a few compounds of argon and other rare gases are reported to have been prepared, such researchers, and the results obtained, may be considered of scientific interest only. For all practical purposes every attempt to make argon combine to give compounds of the usual types, like treatment with oxidizing or reducing agents, has failed. The comparative stability of argon is due to the complete pairing of all electrons present and the absence of any bonding orbitants.

## EMAX ORGANIZATION & MANAGEMENT

### B-5 Health & Safety Practices

---

#### 3.3.2 Liquid Argon

Liquid argon is tasteless, colorless, odorless, non-corrosive, nonflammable, and extremely cold. Belonging to the family of rare inert gases, argon is the most plentiful of the rare gases, making up approximately 1% of the earth's atmosphere.

It is monatomic and extremely inert, forming no known chemical compounds. Special materials of construction are not required to prevent corrosion. However, materials of construction must be selected to withstand the low temperature of liquid argon. Vessels and piping should be designed to American Society of Mechanical Engineers (ASME) specifications or the Department of Transportation (DOT) codes for the pressures and temperatures involved.

Although used more commonly in the gaseous state, argon is commonly stored and transported as a liquid, affording a more cost-effective way of providing product supply. When argon is converted to liquid form it becomes a cryogenic liquid. Cryogenic liquids are liquefied gases that have a normal boiling point below -238°F (-150°C). Liquid argon has a boiling point of -302.6°F (-185.9°C). The temperature difference between the product and the surrounding environment, even in winter, is substantial.

Keeping this surrounding heat from the product requires special equipment to store and handle cryogenic liquids. A typical system consists of the following components: a cryogenic storage tank, one or more vaporizers, a pressure control system, and all of the piping required for fill, vaporization, and supply. The cryogenic tank is constructed like a vacuum bottle. It is designed to keep heat away from the liquid that is contained in the inner vessel. Vaporizers convert the liquid argon to its gaseous state. A pressure control manifold controls the pressure at which the gas is fed to the process.

#### 3.3.3 Helium

Helium is inert, colorless, and tasteless gas and is only slightly soluble in water (0.86 parts in 100 parts). One of the most important characteristics of helium is its extremely low density. Helium is normally supplied as a non-liquified gas compressed into cylinders at a pressure of approximately 2200 p.s.i.g. at 70°F.

A mixture of helium and oxygen finds use as a breathing gas for divers who must work under high pressures. Atmospheres containing helium are used for therapy and an anesthesia of patients suffering from asthma or other obstructive conditions in the respiratory passages.

Helium is nontoxic but can act as an asphyxiant by displacing the necessary amount of air to support life.

Safety Devices: Cylinders containing helium have safety



## EMAX ORGANIZATION & MANAGEMENT

### B-5 Health & Safety Practices

---

devices of the unbacked frangible disc type or frangible disc backed up with fusible metals, melting at approximately 212<sup>o</sup>F. Cylinders pressurized 10% in excess of their marked service pressure in accordance with present D.O.T. regulations must contain only safety devices of the unbacked frangible disc type. These safety devices are an integral part of the cylinder valve, situated opposite the valve outlet.

Shipping Regulations: Helium is shipped in high pressure steel cylinders as a nonflammable compressed gas, taking a D.O.T. "Green Label". They are usually filled to the maximum of 10% in excess of the marked service pressure of the cylinder in accordance with present D.O.T. regulations.

Chemical Properties: Helium is a monatomic chemically inactive gas. It will not react with other elements or compounds under ordinary conditions.

#### 3.3.4 Nitrogen

Nitrogen comprises approximately 79% by volume of the air. It is found chemically combined in many forms in nature. Nitrogen will not burn and will not support combustion. Nitrogen is normally available in cylinders compressed to 200 p.s.i.g.

Nitrogen is non-toxic, but can act as an asphyxiant by displacing the necessary amount of air to sustain life.

Leaks in lines and equipment may be detected by painting the suspected sites with soapy water. Leaks will be evident by the formation of bubbles.

Since nitrogen is inert, no special materials of construction are required. However, any piping or vessels containing nitrogen should be designed to have a working pressure as specified by competent engineers, using a safety factor in compliance with the A.S.M.E. code for pressure piping.

Nitrogen is packed in D.O.T. approved, high-pressure steel cylinders.

Cylinders containing nitrogen have safety devices of either the frangible disc type or frangible disc type backed with fusible metal, melting at approximately 212<sup>o</sup>F. Cylinders pressurized 10% in excess of their marked service pressure in accordance with present D.O.T. regulations must be equipped only with safety devices.

Shipping Regulations: Nitrogen is shipped in high-pressure steel cylinders as a non-flammable compressed gas, taking a D.O.T. "Green Label". The cylinders are usually filled to the marked service pressure of the cylinder or to the maximum of 10% in excess of the marked service pressure, in accordance with present D.O.T. regulations.

Nitrogen is extremely inert, except when heated to very high temperatures where it combines with metal to form nitrides. Nitrogen

## EMAX ORGANIZATION & MANAGEMENT

### B-5 Health & Safety Practices

---

combines with oxygen in an electric arc or gas fired furnace to give an unfavorable equilibrium mixture containing about 2.23% (by volume) nitric oxide. Nitrogen combines with hydrogen at elevated temperatures and pressures in the presence of catalysts to form ammonia. Nitrogen is an essential constituent of all living plant and animal matter, but cannot be utilized by the animal organism to form amino acids. This vital function is carried out only by plants.

#### 3.3.5 Liquid Nitrogen

Liquid nitrogen is a colorless, odorless, extremely cold liquid and gas under pressure. It can cause rapid suffocation when concentrations are sufficient to reduce oxygen levels below 19.5%. Self-Contained Breathing Apparatus (SCBA) may be required.

Contact with liquid or cold vapors can cause severe frostbite. Cold vapors in the air will appear as a white fog due to condensation of moisture. While this may indicate the presence of the gas it should not be used to determine its concentration in the atmosphere. Oxygen concentrations must be monitored in the release area. All cryogenic liquids produce large volumes of gas when they vaporize. One volume of liquid nitrogen will expand to produce 696.5 equivalent volumes of gas.

#### 3.3.6 Hydrogen

Hydrogen is a colorless gas with no odor. It is not toxic; the immediate health hazard is that it may cause thermal burns. It is flammable and may form mixtures with air that are flammable or explosive. Hydrogen may react violently if combined with oxidizers, such as air, oxygen, and halogens. Hydrogen is an asphyxiant and may displace oxygen in a workplace atmosphere. The concentrations at which flammable or explosive mixtures form are much lower than the concentration at which asphyxiation risk is significant.

Hydrogen is not toxic by any route. Asphyxia may result if the oxygen concentration is reduced to below 18% by displacement.

The only safe way to extinguish a flammable gas fire is to stop the flow of gas. If the flow cannot be stopped, allow the entire contents of the cylinder to burn. Cool the cylinder and surroundings with water from a suitable distance. Extinguishing the fire without stopping the flow of gas may permit the formation of ignitable or explosive mixtures with air. These mixtures may propagate to a source of ignition.

Excessive pressure may develop in gas cylinders exposed to fire, which may result in explosion, regardless of the cylinder's content. Cylinders with pressure relief devices (PRD's) may release their contents through such devices if the cylinder is exposed to fire. Cylinders without PRD's have no provision for controlled release and are therefore more likely to explode if exposed to fire.

Protect the cylinders from direct sunlight, precipitation, mechanical damage, and temperatures above 55°C (130°F).

## EMAX ORGANIZATION & MANAGEMENT

### B-5 Health & Safety Practices

---

Ship and store cylinders with the outlet plug and valve protective cap in place.

#### 3.4 Incompatible Materials in the Laboratory

##### DO NOT MIX:

**Alkali Metals:** Calcium, potassium and sodium with water, carbon dioxide, carbon tetrachloride and other chlorinated hydrocarbons.

**Acetylene:** With copper tubing, fluorine, bromine, chlorine, iodine, silver, mercury or their compounds.

**Ammonia, Anhydrous:** With mercury, halogens, calcium hypochlorite or hydrogen fluoride.

**Ammonia Nitrate:** With acids, metal powders, flammable liquids, chlorates, nitrates, sulfur and finely divided organics or other combustibles.

**Chromic Acid:** With acetic acid, naphthalenes, camphor, alcohol glycerine, turpentine and other flammable liquids.

**Chlorine:** With ammonia, acetylene, butadiene, benzene and other petroleum fractions, hydrogen, sodium carbide, turpentine and finely-divided powdered metals.

**Concentrated Acids and Bases and Their Salts:** Will produce large amounts of heat when mixed together with water.

**Cyanides:** With acids.

**Hydrogen Peroxide:** With copper, chromium, iron, most metals or their respective salts, flammable liquids, and other combustible materials, aniline and nitro-methane.

**Hydrogen Sulfide:** With nitric acid, oxidizing gases.

**Hydrocarbons:** With fluorine, chlorine, bromine, chromic acid or sodium peroxide.

**Iodine:** With acetylene or ammonia.

**Mercury:** With acetylene, fulmic acid, hydrogen.

**Nitric Acid:** With acetic, chromic and hydrocyanic acids, aniline, carbon, hydrogen sulfide, flammable liquids or gases and substances which are readily nitrate.

**Perchloric Acid:** With acetic anhydride, bismuth and its alloys, and organic material.

**Potassium Permanganate:** With glycerine, ethylene glycol and sulfuric acid.



## EMAX ORGANIZATION & MANAGEMENT

### B-5 Health & Safety Practices

---

**Sulfuric Acid:** With chlorates, perchlorate, permanganates; and water.

**Hydrofluoric Acid:** Keep in tightly closed polyethylene containers. Store in a cool, dry place with adequate ventilation separated from other chemicals. Protect from physical damage. Storage facilities should be constructed for containment and neutralization of spills. Handling and storage of HF requires special materials and technology for containers, pipes, valves, etc., which is available from suppliers. Containers of this material may be hazardous when empty since they retain product residues (vapors, liquid); observe all warnings and precautions listed for the product.

#### 3.5 Chemical Spills

Alert your neighbors and the supervisor!

For **small** spills only, if there is no fire hazard and the materials are not dangerous, clean up as directed by your supervisor. For **large** spills of liquids, an absorbent material will aid in the clean-up operation. Substances such as Haz-sorb pillows and Zorb-A are good choices. Neutralize acid spills with sodium bicarbonate. Use a dustpan and brush to remove all items used to neutralize and contain the spill. Gloves should be worn. If the spill is on the floor, be sure the area of the spill is dry before leaving-this will prevent slippage by others.

If volatile, flammable or a toxic material is spilled, clearly warn everyone to turn off burners and spark producing equipment. Shut down all experimentation and leave the area. Your supervisor will direct the clean-up effort.

Spilled mercury should be immediately and painstakingly cleaned up using a trapped vacuum line attached to a tapered glass tube similar to a medicine dropper. Cover small droplets in inaccessible spots with sulfur to convert the mercury to mercury sulfide. Droplets of mercury present a large surface area and may generate dangerous concentrations of mercury vapor in the air.

#### **Organic Halogen and Related Compounds (Methylene Chloride, Freon)**

For spills less than 1 liter, clean-up should be under the direction of the Organic Lab Manager. For spills larger than 1 liter, the immediate area should be evacuated until the Laboratory Director and/or Chemical Hygiene Officer permits employees to re-enter the area.

**Gas Leak:** If valve is leaking because it cannot be turned off, the gas can be bubbled through a reducer and excess sodium bicarbonate solution.

**Liquid or Solid:** Cover with a reducer (a bisulfite will work well). Mix well and spray with water. A sulfite will require an addition of some SM - H<sub>2</sub> - SO<sub>4</sub> to promote rapid reduction. Scoop the slurry into the container and neutralize with soda ash. Wash down the drain with large amounts of water.

**IF THE SPILL IS LARGE, LEAVE THE AREA AND GET PROFESSIONAL HELP!**

#### 3.6 Disposal Procedures for Chemical Wastes



## EMAX ORGANIZATION & MANAGEMENT

### B-5 Health & Safety Practices

---

**No Drain Dispose:** No samples or chemicals are allowed to be drain disposed.

**Organic Solvents:** All organic solvents including methylene chloride and Freon are to be placed in 55 gallon waste drums for organic solvent waste. Water and acidified water samples resulting from extractions **should not** be added to organic waste drums under any circumstances.

**Reducing Substances:** (Sulfur Dioxide) Wear rubber gloves, safety goggles, lab coat.

**Heavy Metals** (Lead, Mercury, Cadmium, and their compounds): Wear rubber gloves, lab coat, and in the event of a large mercury spill, use a self-contained breathing apparatus.

**Recovery:** Every effort should be made to recover these chemicals before they can contaminate air or water. Clean up procedures will vary depending on the type and amount of chemical involved. Contain the spill and consult your supervisor for further instructions.

These above four examples are general guidelines to help you safely deal with chemical wastes. **See your supervisor if you have any questions on proper disposal.**

#### 3.7 Potentially Explosive Chemicals (including organic peroxide)

Certain chemicals that are known to be unstable can constitute a serious safety hazard and should be treated accordingly. These materials may deteriorate and become more susceptible from friction, from mechanical impact, from thermal shock or from spontaneous combustion. The materials can be used safely if personnel are familiar with and carefully follow instructions for use, storage and disposal.

A wide variety of chemicals fit this category. Compounds containing "phosphores" contribute to the tendency for a compound to explode. The following is a list of several common phosphores:

| <u>PHOSPHORES</u> | <u>EXAMPLE</u>   |
|-------------------|--|
| Nitro             | Nitromethane, Trinitrophenol (picric acid) and Trinitrotoluene (TNT) |
| Nitramine         | Etylene nitramine  |
| Diazo             | Diazodinitrophenol   |
| Azide             | Lead azide   |
| Peroxide          | Benzoyl peroxide, diethyl ether, and tetrahydrofuran                 |

Diethyl ether may fall into the peroxide category because the influence of air (oxygen) and light promotes oxidation to form organic peroxide. Because this

## EMAX ORGANIZATION & MANAGEMENT

### B-5 Health & Safety Practices

---

oxidation proceeds at a variable rate, depending on many factors, containers of diethyl ether must be dated when received and must be disposed of after a period of six (6) months. This chemical should be purchased in small quantities that can be consumed within six (6) months. Similar limitations apply to tetrahydrofuran and other "peroxide formers".

Ethers with high concentrations of peroxides are extremely sensitive to impact and physical shock and are capable of violent explosion. Ethers with unknown concentrations of peroxides should be handled as if they were booby-trapped. No one should "shake" a container to see how much is in it. Shock-sensitive compounds such as old ethers or old picric acid should be handled with great respect for their explosive power.

When chemicals in the above categories require a disposal, a phone request for disposal hygiene should be made directly to one of the following: (1) Chemical Hygiene Officer, (2) the Safety Officer, and (3) the Fire Marshal. Removal of the problem material will be by the members of the Laboratories' Hazardous Material Emergency Response Team or by the trained outside group of people.

If the material in question has been stored beyond its recommended safe shelf life, appropriate warning signs should be posted emphasizing that the material is not to be touched or moved. The area should be isolated while arrangements are made for proper and safe disposal. The contents may be shock sensitive and any handling by untrained professional could result in a serious accident.

### 3.8 Methylene Chloride Exposure Monitoring.

#### 3.8.1 Policy.

A yearly exposure monitoring shall be performed in the sample preparation area where (CH<sub>2</sub>Cl<sub>2</sub>) Methylene Chloride (MC) is used. As per OSHA PEL (Permissible Exposure Limit), exposure shall not exceed 25 parts MC per million parts of air (25 ppmv) as an eight hour time-weighted average (8-hour TWA PEL) or 125 parts of MC per million parts of air (125 ppmv) averaged over a 15-minute period (STEL).

It is the responsibility of the Safety Officer/Chemical Hygiene Officer to conduct the exposure monitoring at various locations of the sample preparation area.

It is the responsibility of the Safety/Chemical Hygiene Officer to stop the operation when a critical condition is observed or found. Suspension of operation shall only be lifted upon successful resolution of the deficiencies.

It is the responsibility of the operation manager to oversee the implementation and /or enforcement of corrective action and/or recommendation for improvement.

#### 3.8.2 Safety

Dichloromethane is an OSHA "Select Carcinogen" and is a skin and eye irritant. Exposure to high concentration of dichloromethane vapor (>500

## EMAX ORGANIZATION & MANAGEMENT

### B-5 Health & Safety Practices

ppm for 8h) can lead to lightheadedness, fatigue, weakness, and nausea. Contact of the compound with the eyes causes painful irritation and can lead to conjunctivitis and corneal injury if not promptly removed by washing. Dichloromethane is a mild skin irritant, and upon prolonged contact (e.g., under the cover of clothing or shoes) can cause burns after 30 to 60 min exposure. Prolonged exposure to vapors may cause cancer or exacerbate cardiac disease. Dichloromethane is not teratogenic at levels up to 4500 ppm or embryotoxic in rats and mice at levels up to 1250 ppm.

Most people cannot smell methylene chloride until it reaches a hazardous level – so don't depend on your sense of smell to warn you of overexposure. If you can smell it, your exposure is too high.

#### 3.8.3 Instrument and Supplies

|                          |  |
|--------------------------|--|
| Escort Elf Pump          | MSA Escort Elf Pump – P/N 497701 – S/N A2-30987                          |
| Gemini Twin Port Sampler | MSA Gemini Twin Port Sampler - 497697                                    |
| Charcoal Tubes           | Supelco ORBO-32 Large Charcoal Tubes 400/200mg - 20228                   |
| Battery Charger          | MSA Omega Battery Charger P/N 494716 Rev.5, Rapid Charge; Trickle Charge |

#### 3.8.3 Procedure

3.8.3.1 Perform Operations Check as per operation manual.

3.8.3.2 Preset the Escort Elf Pump at 1.5 LPM for proper airflow.

3.8.3.3 Set Gemini Twin Port Sampler at 200 ml/min for each charcoal tubes. See operation manual for Twin Port Sampler on page 1-7.

3.8.3.4 Break the end of the charcoal tubes carefully and place them with the arrows going down into the Twin Port Sampler.

3.8.3.5 Place the Pump and Twin Port Sampler at the desired location and start the pump. Exposure monitoring shall be performed for 8 hour. After approximately 8 hour, stop the pump. The pump will display time in minutes of its operation.

3.8.3.6 Record the time on a chain of custody with the 200 ml/min flow rate. Cap both tubes carefully. Give the tubes and the chain of custody to sample receiving for login and analysis of the Charcoal Tubes.

#### 3.8.4 Quality Control

The permissible exposure limit is 25 part per million part of air. In the event that the PEL is exceeded, the chemical Hygiene officer and management will investigate the cause of the high exposure. The engineering and administrative control will be checked and re-evaluated. Any corrective actions will be discussed with personnel and documented.

## EMAX ORGANIZATION & MANAGEMENT

### B-5 Health & Safety Practices

---

#### 3.8.5 Supplementary notes:

##### 3.8.5.1 Definition of Terms:

Critical Condition: Any results above the OSHA PEL.

#### 4.0 PROTECTIVE EQUIPMENT EVALUATION

The evaluation of protective equipment is addressed in the following:

##### 4.1 Procedures for Checking Safety Showers/Eye Wash

###### 4.1.1 Safety Showers

**Step 1** Find a 5-gallon bucket.

**Step 2** Place bucket and funnel device under safety shower.

**Step 3** Pull chain or push rod on safety shower.

**Step 4** Let shower run for approximately 30 seconds or until the bucket is full. The bucket should have 1 gallon or greater of water after 30 seconds flush.

**Step 5** Release chain or rod on safety shower.

**Step 6** Empty bucket.

**Step 7** Continue flushing until water is clean, then return the bucket to proper place. The water temperature should be in a comfortable range (60-75°F).

**Step 8** Wipe up any water spilled on the floor.

###### 4.1.2 Eye Wash

**Step 1** Start flow of water.

**Step 2** Continue flushing until water is clean.

**Step 3** Observe flow to make sure spray is even and meets in center.

**Step 4** Water temperature should be in a comfortable range (60-75°F).

The Frequency of checking safety showers/eye wash stations is monthly.

##### 4.2 Instruction for Replacing Portable Bottled Emergency Eye Washes

Portable bottled eye washes are used only when a plumbed system is not possible.

**Step 1** Remove expired emergency eye wash containers from holders in each area.



## EMAX ORGANIZATION & MANAGEMENT

### B-5 Health & Safety Practices

---

**Step 2** Replace with new purchased bottled eye washes.

#### 4.3 Local Exhaust Systems.

Ventilation systems such as fume hoods, canopy hoods and other local exhaust system have many uses. These ventilation systems are installed to control exposure to airborne contaminants or to control other internal conditions. To ensure that the ventilation systems are operating properly, they need to be evaluated through the measurement of airflow patterns, velocities and volume. All ventilation systems installed to control exposures to airborne contaminants should have baseline and annual evaluations. These evaluations will be performed in accordance with the following procedures:

##### 4.3.1 Baseline Evaluation

###### 4.3.1.1 Airflow Measurements of Hoods

A **baseline** measurement of airflow patterns, velocities and volume will be made with a Velometer or other similar instrument. Bi-weekly measurements of the airflow patterns, velocities and volumes will be made utilizing the same instrument used during the baseline evaluation. The new measurements will be documented on a Hood Flow Chart. Procedure for the Fume Hood Inspection can be found in EMAX-QC09 SOP.

#### 4.4. Respiratory Protection Program

##### 4.4.1 Policy Statement

The Respiratory Protection Program was established in order to coordinate the use and maintenance of all respiratory protective equipment.

The use of respiratory protective equipment is only necessary under certain conditions in order to: (1) reduce the potential for employee exposure to harmful levels of toxic chemicals and (2) allow employees to enter and work safely in hazardous work environments, such as confined space entry or hazardous waste sites.

The requirements set forth in this policy ensure compliance with the OSHA Respiratory Protection Standard 29 CFR 1910.134.

Evaluation has shown no need for respirators for routing 126 procedures. Engineering controls provide proper chemical control.

##### 4.4.2 Responsibilities

###### 4.4.2.1 Chemical Hygiene Officer

- Evaluate operations to determine if respiratory protection is required.

## EMAX ORGANIZATION & MANAGEMENT

### B-5 Health & Safety Practices

---

- Ensure proper respirator medical exam is provided.
- Supervise the respirator selection process. Ensure the purchase of NIOSH-approved respirators and replacement parts.
- Conduct respirator training and fit testing.
- Evaluate effectiveness of the program.
- Maintain employee respirator records

#### 4.4.2.2 Divisional/Departmental Safety Representatives

- Ensure that employees wear respirators as required.
- Issue respirators.
- Inspect emergency use respirators monthly.
- Maintain records of emergency use respirator inspections.

#### 4.4.2.3 Employees

- Use the respirators assigned to him/her in accordance with instructions and training.
- Clean, disinfect, and inspect his/her respirator.
- Report respirator malfunctions to Divisional/Departmental Safety Representatives.

#### 4.4.3 Respirator Selection

Any operation which exposes employees to harmful dusts, fogs, fumes, mists, gases, smokes, sprays or vapors will be evaluated by the Chemical Hygiene Officer. If respirators are required, the Chemical Hygiene Officer will select a NIOSH-approved respirator based on the hazard(s) to which the employee is exposed. Essential elements to be considered in making the respirator selection include:

The Air Purifying Respirator or Chemical Cartridge Respirator is used at EMAX. A combination of organic vapor and acid fume cartridges are used during activities where the employees may be most exposed without the used of the lab engineering controls. (Waste disposal).

#### 4.4.4 Training and Education

Every employee who may have to wear a respirator must be instructed in the proper selection, use and maintenance of the respirator. Both the employee and the supervisor will receive this training. The training will be repeated at least annually.

##### **Procedure:**

- Inspect the respirator before each use for cleanliness, proper assembly and absence of any damage.
- Position narrow portion of respirator on your nose bridge and place cradle suspension system on your head so that the top headstrap rests across the top of your head.
- Hook the bottom headband behind your neck and position the facepiece for comfort.

## EMAX ORGANIZATION & MANAGEMENT

### B-5 Health & Safety Practices

---

- All the headbands are adjustable. Hold respirator in one hand and pull the straps toward the rear to tighten. To loosen, pull forward on the plastic yoke through which the strap is threaded.
- Check the seal of your respirator by conducting a positive and negative pressure seal check. A seal check should be conducted every time the facepiece is put on and periodically while wearing it.
- To conduct a positive pressure seal check, cover the opening in the exhalation valve guard with the palm of your hand and exhale gently. If an air leak is detected, reposition the facepiece and/or readjust the headband straps. Repeat the check until an effective seal is obtained.
- To conduct a negative pressure seal check, place the palms of your hands over the openings in the filter covers. Inhale enough to collapse the facepiece slightly and hold your breath for five seconds. If the face piece does not remain collapsed, reposition the facepiece and/or readjust the headband straps. Repeat the check until an effective seal is obtained.
- Select a testing location having exhaust ventilation sufficient to avoid general contamination of the area by the irritant smoke, which is used to test the effectiveness of the respirator.
- The employee will be advised that the smoke can be irritating to the eyes and instruct the subject to keep his/her eyes closed while the test is performed. Proceed with the fit test using the instructions provided in the fit test kit using irritant smoke.
- After the use of the respirator, the respirator must be cleaned with an alcohol wipe pad and placed in the seal plastic bag provided.

#### 4.5 Program Evaluation

The Chemical Hygiene Officer must evaluate the effectiveness of the respiratory protection program. This on-going evaluation process should include:

- Periodic review of feasible engineering, administrative, or work practice control measures that could be initiated to eliminate or reduce employee exposure to air contaminants.
- Random inspections to assure that employees have been trained and are wearing the correct respirator, and that the respirators are properly maintained and stored.
- Periodic checks to assure that the record keeping requirements are being fulfilled. Record and date the above inspections/evaluations.

#### 4.6 Respiratory Protective Equipment: Use and Limitations

##### 4.6.1 Air Purifying Respirators

## EMAX ORGANIZATION & MANAGEMENT

### B-5 Health & Safety Practices

---

#### 4.6.2 Chemical Cartridges Respirators Limitations

**DO NOT USE** chemical cartridge respirator's for the following materials:

1. Acroline
2. Aniline
3. Arsine
4. Bromine
5. Carbon monoxide
6. Dimethylaniline
7. Dimethyl sulfate
8. Hydrogen cyanide
9. Hydrogen fluoride
10. Hydrogen selenide
11. Hydrogen sulfide
12. Methanol
13. Methyl bromide
14. Methyl chloride
15. Methyl biphenyl isocyanate
16. Nickel carbonyl
17. Nitro compounds
  - Nitrobenzene
  - Nitrogen oxides
  - Nitroglycerine
  - Nitromethane
18. Ozone
19. Phosgene
20. Phosphine
21. Phosphorous trichloride
22. Stibine
23. Sulfur chloride
24. Toluene diisocyanate
25. Vinyl chloride

**Note:** The above list is far from complete and is offered only as a guide to proper evaluation of the many contaminants found.



## EMAX ORGANIZATION & MANAGEMENT

### B-5 Health & Safety Practices

---

#### 4.7 Respirator Physical Evaluation Form

NAME: \_\_\_\_\_ AGE: \_\_\_\_\_ BIRTHDATE: \_\_\_\_\_

HEIGHT: \_\_\_\_\_ WEIGHT: \_\_\_\_\_

Do you have or have you ever had any of the following?

|  | Yes   | No    |
|--|-------|-------|
| a. Diabetes  | _____ | _____ |
| b. Seizures or convulsions   | _____ | _____ |
| c. Alcohol dependency or abuse   | _____ | _____ |
| d. Punctured ear drums   | _____ | _____ |
| e. Skin disorders (dermatitis/allergies)   | _____ | _____ |
| f. Trouble smelling  | _____ | _____ |
| g. Lung problem such as asthma, emphysema, TB, x-ray evidence of pneumoconiosis, reduced lung function, etc. | _____ | _____ |
| h. Heart disease   | _____ | _____ |
| i. Stroke  | _____ | _____ |
| j. High blood pressure   | _____ | _____ |
| k. Anemia (low blood/low hemoglobin)   | _____ | _____ |
| l. Surgery to head/face-other than dental  | _____ | _____ |
| m. Had trouble breathing when wearing a respirator   | _____ | _____ |
| n. Claustrophobia when wearing a respirator  | _____ | _____ |
| o. Any medical condition, which you feel could be a problem when wearing a respirator.                       | _____ | _____ |
| p. Significant weight gain (since last filling out this form)  | _____ | _____ |

If you answer yes to any of the above, please explain your answer on the reverse side of this sheet. Include any treatment and results.

List on the reverse side of this sheet any prescription medications you take on a regular basis.

The above is, to the best of my knowledge, a truthful statement concerning my present health.

\_\_\_\_\_  
Signature

\_\_\_\_\_  
Date

## EMAX ORGANIZATION & MANAGEMENT

### B-5 Health & Safety Practices

---

#### 4.8 Medical Summary Form

Name: \_\_\_\_\_ Social Security No.: \_\_\_\_\_

Date of Physical Exam: \_\_\_\_\_

#### MEDICAL SUMMARY

|   | <u>COMMENTS</u>              | <u>NORMAL</u> |           |
|---|------------------------------|---------------|-----------|
|   |                              | <u>YES</u>    | <u>NO</u> |
| A | Laboratory Tests             |               |           |
|   | 1. Pulmonary Function Tests: | _____         | _____     |
|   | 2. Chest X-Ray:              | _____         | _____     |
|   | 3. Vision Screening:         | _____         | _____     |
|   | 4. Hematology Survey:        | _____         | _____     |
|   | 5. Urinalysis:               | _____         | _____     |
|   | 6. Heavy Metal Screen:       | _____         | _____     |
|   | 7. Blood Chemistry Screen:   | _____         | _____     |
|   | 8. Audiogram:                | _____         | _____     |

B. Examiners Summary of Ability to Wear a Respirator  
Self-Contained Breathing Apparatus and Negative Pressure Respirators

C. Examiners Summary of Physical/Medical Summary

D. Any Additional Comments/Recommendations

\_\_\_\_\_  
Signature M.D. Date \_\_\_\_\_

I understand that this form will be released to EMAX Laboratories, Incorporated and I will receive a copy. I also understand that EMAX Laboratories, Incorporated retains the right to access my medical record as needed.

\_\_\_\_\_  
Signature Date \_\_\_\_\_

## **EMAX ORGANIZATION & MANAGEMENT**

### **B-5 Health & Safety Practices**

---

#### **5.0 Employee Information and Training**

##### **5.1 Employee Information**

The Occupational Safety and Health permissible exposure limits (PEL) are available from the Chemical Hygiene Officer. Signs and symptoms associated with overexposure to hazardous chemicals used in the laboratory are discussed on the Safety Data Sheets, as well as product labels and known reference material. Additional reference material is available by contacting the Corporate Safety Officer. Safety Data Sheets are available upon request and a copy will be provided upon request.

##### **5.2 Employee Training**

###### **5.2.1 Training Statement**

EMAX Laboratories, Incorporated is firmly committed in providing each of its employees a safe and healthy work environment. It is important that employees in these situations are aware of the identity and/or toxic or other hazardous properties of the chemical, since an informed employee is more likely to be a careful employee.

The success of our training depends to a great extent upon the cooperation of every employee. Employees should be alert to the potential hazards of all the chemicals in the work area, consult the Safety Data Sheet for specifics concerning the hazardous chemicals with which they work, follow the appropriate work practices that have been established to protect their health and safety.

Active employee participation in our training program will result in the continued prevention of chemical-related illnesses and injuries.

###### **5.2.2 Safety Data Sheets**

A "chemical inventory" will be maintained by the Chemical Hygiene Officer. This inventory will list each hazardous substances used. The inventory will be updated when new substances are procured.

A safety data sheet (SDS) containing the information required by the Federal Hazard Communication Standard will be kept for each substance listed on the "chemical inventory". The SDS will be the most current one supplied by the chemical manufacturer, importer or distributor.

The SDS's will be filed in the Safety Data Sheet Notebook, alphabetically by the name identified in the chemical inventory. The original SDS's will be filed in a Master SDS notebook.

## EMAX ORGANIZATION & MANAGEMENT

### B-5 Health & Safety Practices

---

No hazardous material will be used in the workplace unless an SDS has been obtained and is on file. For new chemicals, an SDS should be requested at the time of purchase.

A new health information becomes available about any hazardous material on the inventory, a revised Safety Data Sheet will be placed in the SDS file. Each Divisional/Departmental Safety Representatives will review revised SDS's for their division/department. The employee who handles or might be exposed to the material will be notified if there are any changes in work procedures or personal protective equipment requirements.

Safety Data Sheets will be made readily available to all employees on any work shift, as well as to representatives of State or the Federal Occupational Safety and Health and to the employee's physician. The SDS Library is maintained in the office of the Health and Safety Officer.

#### 5.2.3 Labeling Policy

Employees will accept no hazardous chemicals for use unless labeled with at least the following information:

- Identity of the hazardous chemical (trade or chemical name)
- Appropriate hazard warnings
- Names and address of the chemical manufacturer

If the hazardous chemical is regulated by OSHA in a substance specific health standard, the label used will be in accordance with the requirements of that standard (see Section 6.1 for list).

In certain situations involving stationary process containers, the label may be replaced by a sign or a SDS.

Any portable container of hazardous chemicals will be labeled with the appropriate information from the shipping label. Employees with questions concerning the appropriate information to use on a label, should check with their divisional/departmental Safety Representatives.

Bottles of reagents will be labeled as follows:

- Reagent name
- Test name
- Preparation Date and Initials
- Expiration Date

The label information obtained from "Standard Methods" when the reagents are being prepared. The reagent must also be entered into the "Reagent Logbook".

## **EMAX ORGANIZATION & MANAGEMENT**

### **B-5 Health & Safety Practices**

---

The identity of the material that appears on the manufacturer's label or the in-house label will be the same name used to identify the material on the "chemical inventory" and the SDS for that substance.

All labels will be legible and prominently displayed on the container.

#### **5.2.4 Hazard Determination**

EMAX Laboratories, Incorporated will rely on the chemical manufacturer's hazard evaluation for all chemicals purchased.

The Chemical Hygiene Officer will review SDS's on new products to determine appropriate work practices and protective equipment requirements. (See section 3 for further criteria).

#### **5.2.5 Employee Training**

All employees who may be routinely exposed to hazardous substances or harmful physical agents will be provided with training.

Training must be provided to an employee prior to initial assignment to a workplace where the employee may be routinely exposed to a hazardous substance or harmful physical agent.

Divisional/Departmental Safety Representative will be responsible for coordinating new employee training sessions with the Personnel Section.

If a new chemical is introduced into a work area, each affected employee will be appropriately trained prior to using the new chemical. This training will be in the form of a SDS review at Departmental meetings.

Records must be kept of each training session. The record must include the date of the session, the type of session and an attendance list. These records will be retained for five years and made readily available, upon request, for review by employees and representatives of State or Federal Occupational Safety and Health Administrations.

Before any non-routine task is performed that could involve exposure to hazardous chemicals the employee's supervisor will carefully review all potential hazards of the task with the work area(s) that the contractor's employees will be working in. The SDS for the relevant chemicals will be available to the contractor upon request.

As part of the contractual arrangement between any outside contractor and the contractor must list all hazardous chemicals that are to be used by his employees in the course of their work



## **EMAX ORGANIZATION & MANAGEMENT**

### **B-5 Health & Safety Practices**

---

on company property, so that employees may receive the necessary information and training concerning the potential hazards of the substances to which they may be exposed.

Furthermore, prior to beginning work on Company property, the contractor must certify that his/her employees have been trained. As necessary, the CHO will identify particular hazards associated with the work area(s) that the contractor's employees will be working in. The SDS for the relevant chemicals will be available to the contractor upon request.

#### **5.2.6 Execution/Assigned Responsibilities**

The execution and assigned responsibilities for the Chemical Hygiene Plan shall be as described in this section. Each department will be responsible for assigning specific individuals to ensure that the program is executed as required. The individuals or sections will perform the tasks identified as follows:

##### **5.2.6.1 Purchasing Section**

- Maintain the chemical inventory.
- Ensure the availability of the SDS for each substance on the chemical inventory.
- Request SDS's from manufacturer when not available.
- Maintain Master SDS Notebooks.

##### **5.2.6.2 Departmental Safety Representative**

- Maintain work Area SDS Notebook.
- Review new SDS's at Departmental meetings.
- Coordinate new employee training
- Ensure that all containers for hazardous substances in their departments are properly labeled.

##### **5.2.6.3 Personnel Section**

- Maintain training record.
- Coordinate and schedule new employee and annual training sessions with the Chemical Hygiene Officer to ensure that all employees requiring the training are trained on an annual basis.
- Ensure that contractual agreements with outside contractors address hazardous substance use.
- Inform Bench employees of the contractor hazards.
- Inform contractor's of applicable chemical hazards.

##### **5.2.6.4 Chemical Hygiene Officer**

- Conducts or coordinates training.
- Provides technical assistance as required.

## **EMAX ORGANIZATION & MANAGEMENT**

### **B-5 Health & Safety Practices**

---

- Develops training program.

#### **5.2.7 Fire Extinguisher Training**

All personnel shall receive fire extinguisher training on an ANNUAL basis. The training shall include the general principles of fire extinguisher use, the classes of fires and the appropriate fire extinguisher for each class and the operation of the various types of fire extinguishers.

The annual training will be coordinated by the Chemical Hygiene Officer. Documentation of the training will be recorded in each employees training record by the Departmental Safety Officer. Fire extinguisher training is mandatory and is required by 29 CFR 1910.157.

##### **5.2.7.1 Portable Fire Extinguishers**

- Where the employer has provided portable fire extinguishers for employee use in the workplace, the employee shall also provide an educational program to familiarize employees with the general principles of fire extinguisher use and the hazards involved with incipient stage fire fighting.
- The employer shall provide the education required in the above paragraph upon initial employment and at least annually thereafter.
- The employer shall provide employees who have been designated to use fire-fighting equipment as part of an emergency action plan with training in the use of the appropriate equipment.
- The employer shall provide the training required in the above paragraph upon the initial assignment to the designated group of employees and at least annually thereafter.

#### **5.2.8 First Aid/CPR Training**

##### **5.2.8.1 Mandatory Training**

First Aid and CPR training is required for any personnel who wear respiratory protective equipment during confined space entries or who conduct field operations where an infirmary, clinic or hospital is not near proximity to the worksite.

##### **5.2.8.2 29 CFR 1910.151**

In the absence of an infirmary, clinic or hospital in near proximity to the workplace, which is used for the treatment of all injured employees, a person or persons shall be adequately trained to render first aid. First aid

## EMAX ORGANIZATION & MANAGEMENT

### B-5 Health & Safety Practices

---

supplies approved by the consulting physician shall be readily available.

#### 5.2.8.3 Voluntary

It is desired to have as many people trained in First Aid and CPR as possible. For those personnel who are interested in this training, EMAX Laboratories, Incorporated will reimburse any employee the cost of obtaining First Aid and/or CPR training; however, the training must be obtained during non-working hours.

## 6.0 Medical Consultation and Medical Examinations

### 6.1 Medical Examinations

Where exposure monitoring reveals an exposure level **routinely** above the action level for an OSHA regulated substance for which there are medical surveillance requirements, medical surveillance shall be established for the affected employee as prescribed by the particular standard.

### 6.2 Medical Consultation

Whenever an event takes place in work areas such as a spill, leak, explosion, or other occurrence resulting in the likelihood of a significant exposure to a hazardous chemical, the employee shall be provided the opportunity for a medical consultation. Such consultation shall be for the purpose of determining the need for medical examinations and consultations shall be performed by a licensed physician and shall be provided without cost to the employee, without loss of pay and at a reasonable time and place. Whenever an employee develops signs and symptoms associated with a hazardous chemical to which the employee may have been exposed in the laboratory, the employee shall be provided an opportunity to receive an appropriate medical examination.

### 6.3 Information Provided to the Physician

EMAX Laboratories, Incorporated shall provide the following information to the physician:

1. The identity of the hazardous chemical(s) to which the employee may have been exposed; and
2. A description of the signs and symptoms of exposure that the employee is experiencing, if any.

### 6.4 Physician Written Opinion

EMAX Laboratories, Incorporated must obtain a written opinion from the examining physician which includes:

1. Any recommendation for further medical follow-up
2. The results of the medical examination and any associated tests.



## EMAX ORGANIZATION & MANAGEMENT

### B-5 Health & Safety Practices

---

3. Any medical condition which may be revealed in the course of the examination which may place the employee at increased risk as a result of exposure to a hazardous chemical.
4. A statement that the employee has been informed by the physician and any medical condition that may require further examination and treatment.



The written opinion shall not reveal specific findings of diagnosis unrelated to occupational exposure.

#### **6.5 Record Keeping**

EMAX Laboratories, Incorporated shall establish and maintain for each employee an accurate record of any measurements taken to monitor employee exposures and any medical consultation and examinations including tests or written physical opinions. These records must be preserved and maintained for at least the duration of employment plus 30 year.

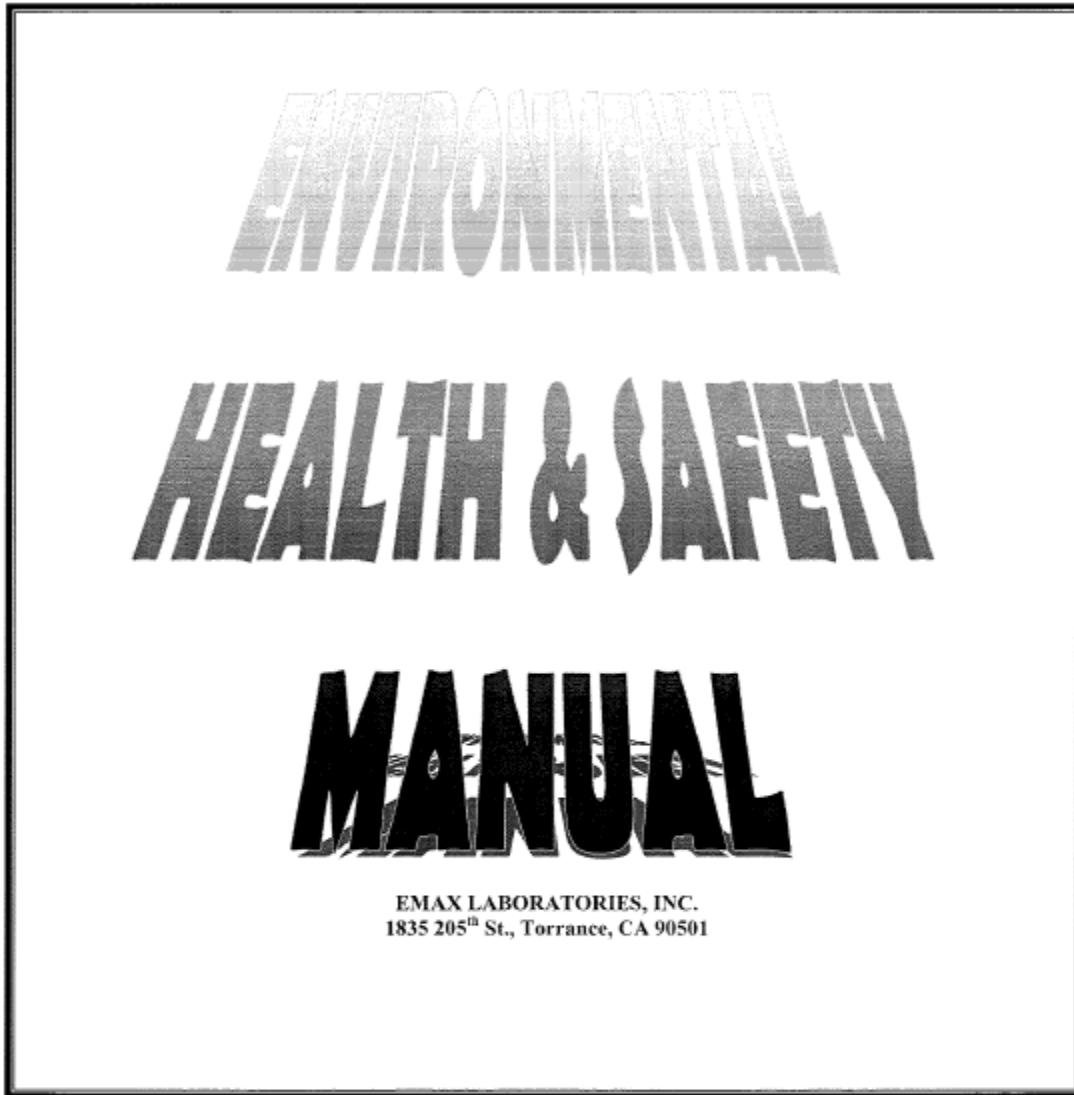
**EMAX ORGANIZATION & MANAGEMENT**  
**B-5 Health & Safety Practices**



|             |   |           |
|-------------|---|-----------|
| Approved By |  | 8/26/19   |
|             | Richard Beauvil, Safety Officer   | Date      |
| Approved By |  | 8/26/2019 |
|             | Caspar Pang, President  | Date      |

|               |              |
|---------------|--------------|
| Document ID   | EMAX-HSM-05  |
| Revision No.  | 5            |
| Date Released | 08/26/19     |
| Issue No.     | EMAX-HSM-05- |
| Issued To     |              |

## EMAX ORGANIZATION & MANAGEMENT

### B-5 Health & Safety Practices

---

#### TABLE OF CONTENTS

|   |           |
|---|-----------|
| TABLE OF CONTENTS.....  | 2         |
| ENVIRONMENTAL HEALTH & SAFETY POLICY .....                      | 4         |
| HEALTH AND SAFETY PROGRAM STRUCTURE.....                        | 4         |
| <b>1.0 RESPONSIBILITIES.....</b>                                | <b>5</b>  |
| 1.1. Health and Safety Officer .....                            | 5         |
| 1.2. Radiation Safety Officer .....                             | 5         |
| 1.3. Safety Committee .....                                     | 6         |
| 1.4. Department Safety Coordinator.....                         | 6         |
| 1.5. Supervisors .....  | 7         |
| 1.6. All Employees .....  | 7         |
| <b>2.0 HEALTH AND SAFETY RULES &amp; REGULATIONS .....</b>      | <b>8</b>  |
| 2.1. Work Ethics .....  | 8         |
| 2.2. Protective Gear .....                                      | 8         |
| 2.3. Food & Beverages .....                                     | 8         |
| 2.4. Chemicals .....  | 8         |
| 2.5. Facility.....  | 8         |
| 2.6. Ensuring Compliance.....                                   | 9         |
| 2.7. Embryo/Fetus Policy .....                                  | 9         |
| <b>3.0 HEALTH AND SAFETY ORIENTATION .....</b>                  | <b>10</b> |
| <b>4.0 EMPLOYEE HEALTH AND SAFETY TRAINING .....</b>            | <b>11</b> |
| 4.1. Initial Training.....                                      | 11        |
| 4.2. Training on Specific Hazards .....                         | 11        |
| 4.3. Safety Videos.....   | 12        |
| 4.4. Safety Data Sheets .....                                   | 12        |
| 4.5. Equipment Operating Manuals .....                          | 12        |
| <b>5.0 INJURY &amp; ILLNESS PREVENTION PROGRAM (IIPP) .....</b> | <b>15</b> |
| 5.1. Identifying Workplace Hazards .....                        | 15        |
| 5.2. Communicating Workplace Hazards .....                      | 15        |
| 5.3. Correcting Workplace Hazards.....                          | 15        |
| 5.4. Investigating Injuries And Illnesses .....                 | 16        |
| <b>6.0 EMERGENCY PROCEDURES .....</b>                           | <b>18</b> |
| 6.1. Emergency Fire Procedure.....                              | 18        |
| 6.1.1. Fighting a Fire.....                                     | 18        |
| 6.1.2. Types of Fire Extinguishers Used in the Laboratory ..... | 18        |
| 6.1.3. Using a Fire Extinguisher .....                          | 18        |
| 6.1.4. Fire Safety Tips.....                                    | 19        |
| 6.2. Emergency Procedures For Chemical Spillage.....            | 19        |
| 6.2.1. Organic acids (limited to C, H and O composition).....   | 19        |
| 6.2.2. Inorganic acids.....                                     | 19        |
| 6.2.3. Alkalis.....   | 19        |
| 6.2.4. Mercury Spills .....                                     | 20        |
| 6.3. Electrical Safety Guidelines.....                          | 20        |
| 6.3.1. General Electrical Safety .....                          | 20        |
| 6.3.2. Extension Cords.....                                     | 20        |

## EMAX ORGANIZATION & MANAGEMENT

### B-5 Health & Safety Practices

---

|   |           |
|---|-----------|
| 6.3.3. Electrical Panels.....                                       | 20        |
| 6.3.4. Electrical Emergency Response.....                           | 21        |
| <b>7.0 HEALTH AND SAFETY PROGRAM EVALUATION.....</b>                | <b>22</b> |
| 7.1. General Inspection.....  | 22        |
| 7.2. Self-Inspection.....   | 22        |
| <b>8.0 RECORD KEEPING.....</b>                                      | <b>22</b> |
| 8.1. Documents Maintained by Health and Safety Office.....          | 22        |
| <b>9.0 FORMS.....</b>   | <b>23</b> |
| Report of Unsafe Condition or Hazard.....                           | 24        |
| Hazard Correction Report.....                                       | 25        |
| Occupational Accident, Injury and Illness Investigation Report..... | 26        |
| New Employee Safety Training Record.....                            | 27        |
| Health and Safety Orientation Form.....                             | 26        |
| Health and Safety Orientation Tour.....                             | 27        |
| Safety Training Attendance Record.....                              | 28        |
| Safety Committee Meeting Documentation.....                         | 29        |
| Laboratory Inspection Form.....                                     | 30        |
| General Inspection Form.....  | 35        |
| Emergency Evacuation Route.....                                     | 38        |
| Location of Safety Material and Equipment.....                      | 39        |

## EMAX ORGANIZATION & MANAGEMENT

### B-5 Health & Safety Practices

---

#### Environmental Health & Safety Policy

At EMAX the health and safety of our employees comes first. Management is committed to doing everything possible to prevent injuries and to maintain a healthy environment.

- All supervisors are responsible for ensuring that employees are trained in approved work procedures to obtain optimal output without accidents or injuries and to ensure that employees follow safe work methods by adhering to safety regulations.
- All personnel are required to support the Health and Safety program and make safety and health a part of their daily routine and to ensure that they are following safe work methods and relevant regulations;
- All personnel will be held accountable for implementing this program; and all relevant laws and regulations are incorporated in our program as minimum standards

#### Health and Safety Structure Program Structure

The Health and Safety Manual describes management's commitment to promote health and safety for all employees in the workplace. Any deviation and/or departure from policies established in this manual shall require a duly approved addendum or new revision. The manual is reviewed annually and revisions are issued as appropriate to keep up to date. All revisions to the manual are recorded in the revision history. Obsolete copies of the manual are kept for at least one (1) year. The program sections are described as follows:

- 1.0 The Health and Safety officer and safety committee are responsible for the formulation and implementation of the program. The Health and Safety Committee is comprised of members who are active participants in the development, implementation, and monitoring of all phases of the health and safety program.
- 2.0 The Health and Safety Program describes the safety rules and regulations specific to health safety concerns in the workplace, it's enforcement and the consequences when the rules are not followed.
- 3.0 Health and Safety Orientation describes the orientation process when an employee joins the organization. Specifically included are the policies, rules and the line of authority in the administration.
- 4.0 Training describes the implementation of health and safety policies into specific job practices and to raise awareness and skill levels to an acceptable standard.
- 5.0 The Injury & Illness Prevention Program establishes a framework for identifying and correcting workplace hazards within the company, and describes the process of identifying existing hazards to recommend appropriate corrective action. It describes obtaining medical care and/or first aid when necessary.
- 6.0 The Emergency Procedures describe the procedures for chemical spills, fire, and work injuries.
- 7.0 The Health and Safety Evaluation describes the process of departmental internal inspection to create environmental health and safety awareness within each department. It provides guidelines for performing regular workplace inspections.
- 8.0 Record Keeping describes essential record generation, maintenance and the procedure of archiving.

## EMAX ORGANIZATION & MANAGEMENT

### B-5 Health & Safety Practices

---

#### 1.0 RESPONSIBILITIES

Department Supervisors have primary authority and responsibility to ensure departmental implementation of the Injury and Illness Prevention Program (IIPP) and to ensure the health and safety of the employees. This is accomplished by communicating emphasis on health and safety, analyzing work procedures for hazard identification along with correction, ensuring regular workplace inspections, providing health and safety training and encouraging prompt employee reporting of health and safety concerns without fear of reprisal.

##### 1.1. Health and Safety Officer

Responsibilities:

- To develop and implement the safety program procedure in the laboratory.
- To ensure all health and safety regulations are observed.
- To ensure all issues of concern are related to the laboratory Director.
- To train new employees.
- To develop, administer and update the Health and Safety manual, the Chemical Hygiene Plan, and the Right-to-Know manual.
- To maintain Safety Data Sheets (SDS) and to provide training in their use.
- To monitor the procurement, use and disposal of chemicals in the laboratory.

Qualifications:

- Education: Minimum of Bachelor's degree in chemistry or any science/engineering discipline or equivalent, with 40 hour training on Hazardous Waste Management.
- Experience: Minimum of one-year experience in administering health and safety regulations.

##### 1.2. Radiation Safety Officer (RSO)

Responsibilities:

- To develop and implement the Radiation Protection Program.
- To direct the use of radioactive material for its intended purpose in a manner that protects the health and minimizes the danger to life or property.
- To ensure that personnel radiation exposure be maintained As-Low-As-Reasonably-Achievable (ALARA).
- To train new employees in safe work practices.

Qualifications:

- Education: Minimum of Bachelor's degree in chemistry, any science/engineering discipline or equivalent. Qualified Officer must have completed Radiation Safety School and have received the RSO certification.
- Experience: Minimum of one(1) year applied experience dealing with radiation principles and practices in an analytical laboratory or equivalent.

##### 1.3. Safety Committee

The Safety Committee shall have a representative from each department. The Safety Committee has the ongoing responsibility to maintain and update this Injury and Illness Prevention Program (IIPP), to assess

## EMAX ORGANIZATION & MANAGEMENT

### B-5 Health & Safety Practices

---

departmental compliance with applicable regulations and policies, to evaluate reports of unsafe condition, and to coordinate any necessary corrective actions. The Safety Committee is to meet on a yearly basis or as needed. Currently, the department's Safety Committee consists of:

The Safety Committee membership may rotate periodically.

Unsafe conditions that cannot be immediately corrected by an employee and/or his/her supervisor should be reported to the Department Safety Coordinator or any Safety Committee member by filling out a "Report of Unsafe Condition or Hazard" form.

The Safety Committee will be responsible for reporting unsafe conditions and injury on a timely manner. The Safety Committee will:

- Review the results of workplace inspections to identify any necessary safety procedures or programs.
- Track specific corrective actions.
- Review supervisors' investigations of accidents and injuries to ensure that all causes have been identified and corrected.
- Where appropriate, submit suggestions to management for the prevention of future incidents.
- Review alleged hazardous conditions brought to the attention of any committee member, determine necessary corrective actions, and assign responsible parties and correction deadlines
- When determined necessary by the Committee, the Committee may conduct its own investigation of accidents and/or alleged hazards to assist in establishing corrective actions
- Submit recommendations to assist department management in the evaluation of employee safety suggestions

The Safety Committee shall prepare and make available to all department personnel written minutes of issues discussed at the meetings. The Committee meeting minutes must be documented. These minutes are posted at the lunchroom and shall be mentioned on QA meetings.

#### 1.4. Department Safety Coordinator

The Safety Coordinator has responsibility for:

- Ensuring that the Safety Committee is aware of all accidents which have occurred, and all hazards which have been observed since the last meeting
- Working with the Building Coordinator to address facility-related safety concerns
- Assisting in the coordination of required health and safety training
- Serving as liaison with HEALTH AND SAFETY and other campus safety resources on issues the department cannot resolve
- Maintaining copies of Safety Committee minutes and other safety-related records
- The Safety Coordinator may seek assistance from other members of the department as necessary to meet these responsibilities.

#### 1.5. Supervisors

Supervisors play a key role in the implementation of the department's IIPP. (For the purpose of this template, the term "supervisor" includes any employee who oversees the work of others.) They are responsible for:

- Communicating to their staff with appropriate emphasis on health and safety
- Ensuring periodic, documented inspection of workspaces under their authority



## EMAX ORGANIZATION & MANAGEMENT

### B-5 Health & Safety Practices

---

- Promptly correcting identified hazards
- Modeling and enforcing safe and healthful work practices
- Providing appropriate safety training and personal protective equipment
- Implementing measures to eliminate or control workplace hazards
- Stopping any employee's work that poses an imminent hazard to either the employee or any other individual
- Encouraging employees to report health and safety issues to the Safety Committee without fear of reprisal

#### 1.6. All Employees

It is the responsibility of all staff to comply with all applicable health and safety regulations, EMAX HEALTH AND SAFETY policies, and established work practices. This includes but is not limited to:

- Observing health and safety-related signs, posters, warning signals and directions
- Reviewing the building emergency plan and assembly area
- Learning about the potential hazards of assigned tasks and work areas
- Taking part in appropriate health and safety training
- Following all safe operating procedures and precautions
- Using proper personal protective equipment
- Warning coworkers about defective equipment and other hazards
- Reporting unsafe conditions immediately to a supervisor, and stopping work if an imminent hazard is presented
- Participating in workplace safety inspections



## EMAX ORGANIZATION & MANAGEMENT

### B-5 Health & Safety Practices

---

#### 2.0 HEALTH AND SAFETY RULES & REGULATIONS

##### 2.1. Work Ethics

- 2.1.1. All new employees must undergo Health and Safety orientation prior to commencement of work.
- 2.1.2. All employees shall undergo safety training applicable to the activities they perform prior to performance of work.

##### 2.2. Protective Gears

- 2.2.1. A closed-toe shoe is the only footwear that can be used while working in the laboratories.
- 2.2.2. Short pants and skirts are not allowed in the laboratories.
- 2.2.3. Lab coats shall be worn in the laboratories while performing activities involving instrumentation, samples or chemicals and must be removed when leaving the lab. Lab coats are not to be worn when going to the lunchroom, restrooms or the front offices.
- 2.2.4. Safety glasses shall be worn at all times as prescribed by the safety procedures of the activity being performed. Safety glasses shall be worn by administrative staff in areas of the lab, where hazards (physical or chemical) are present. Contact lenses are not allowed in the laboratories.
- 2.2.5. Face shields shall be worn at all times when handling corrosive chemicals e.g. concentrated acids or concentrated bases.
- 2.2.6. Gloves shall be worn at all times when handling samples, chemicals and as prescribed by the safety procedures of the activity being performed. Gloves shall be removed while performing administrative tasks. (Keyboards, logbooks, etc.). Gloves shall not be worn in the lunchroom, restrooms and front offices.
- 2.2.7. Respiratory protective equipment shall be worn when working with known toxic chemicals in confined spaces.
- 2.2.8. Earplugs shall be worn when working with a pulse sonicator or other equipment that produces the same noise level of  $\geq 140$  decibels.

##### 2.3. Food & Beverages

- 2.3.1. The lunchroom is the only place where food can be stored for a very short periods and consumed. Overnight storage of perishable is not permitted.
- 2.3.2. No eating, drinking or chewing gum in the laboratories.

##### 2.4. Chemicals

- 2.4.1. All chemicals shall be labeled properly.
- 2.4.2. All chemicals should be contained in a chemical carrier while transporting.
- 2.4.3. Incompatible chemicals must be stored separately.

##### 2.5. Facility

- 2.5.1. Proper ventilation must be maintained in every workspace.
- 2.5.2. Cleanliness must be observed at all times.

## EMAX ORGANIZATION & MANAGEMENT

### B-5 Health & Safety Practices

---

- 2.5.3. Wet floors must be flagged with caution signs.
  - 2.5.4. Fire extinguishers must be properly located, inspected, and maintained
  - 2.5.5. First Aid kits must be properly located, inspected, and supplied.
  - 2.5.6. Emergency eyewash and shower stations must be inspected.
- 2.6. **Ensuring Compliance**
- 2.6.1. All personnel have the responsibility for complying with safe and healthful work practices including applicable regulations, Health and Safety policy, and safety procedures. Overall performance in maintenance of a safe and healthful work environment should be recognized by the supervisor and noted in performance evaluations. Employees will not be discriminated against for work-related injuries, and injuries will not be listed in performance evaluations, unless the injuries were a result of an unsafe act on the part of the employee.
  - 2.6.2. Standard progressive disciplinary measures in accordance with the applicable personnel policy will result when employees fail to comply with applicable regulations of the Health and Safety policy, and/or safety procedures. Staff members will be disciplined for unsafe practices in accordance with the EMAX Code of Conduct contained in the Human Resources Manual. All personnel will be given instruction and an opportunity to correct unsafe behavior. Repeated failure to comply or willful and intentional non-compliance may result in disciplinary measures up to and including termination.
- 2.7. **Embryo/Fetus Policy**
- 2.7.1. EMAX policies shall ensure that employees that are pregnant are protected from hazardous chemicals and radioactive materials. EMAX shall provide right to know training for all employees on Embryo/Fetus policy. Employees who are pregnant shall declare their pregnancy to EMAX human resources for their protection and the protection of the unborn child. EMAX shall discuss potential chemicals and radioactive exposure for employees working in the lab and options for the remainder of their work during the pregnancy.
  - 2.7.2. Exposure of the unborn child shall not exceed 500 millirem for the entire gestation period. Individuals are encouraged to notify human resources and the RSO regarding "declared pregnancies".

## EMAX ORGANIZATION & MANAGEMENT

### B-5 Health & Safety Practices

---

#### 3.0 HEALTH AND SAFETY ORIENTATION

Health and safety education should start with employee orientation when an employee joins the organization or is transferred to a new job. At a minimum Health and Safety orientation should include the following:

- 3.1. Health and Safety rules and regulations
- 3.2. Reasons for each health and safety rule
- 3.3. Emergency procedures
- 3.4. Location of first aid stations
- 3.5. Reporting of injuries, unsafe conditions and acts
- 3.6. Use of personal protective equipment
- 3.7. Right to refuse hazardous work
- 3.8. Hazards, including those outside own work area

A new employee can be expected to absorb only a certain amount of information in the first few days. A brochure outlining the points covered in the orientation sessions is useful as a handout to employees. It also serves as a checklist for the person conducting the orientation. A mentor system is a useful follow-up to the initial orientation. This allows for on-the-job reinforcement of the information presented to the new employee. This process promotes the safety awareness of the experienced workers who are the "mentors".

New, inexperienced or transferred employees should be encouraged to ask questions at any time when doubt exists as to correct procedures.

The supervisor or one of the analysts working in the same department will be the new employee's mentor for the first few months. During that period, the new employee will be trained according to EMAX.QA05.

## EMAX ORGANIZATION & MANAGEMENT

### B-5 Health & Safety Practices

---

#### 4.0 EMPLOYEE HEALTH AND SAFETY TRAINING

Employee safety training is conducted during the employee's normal working hours on EMAX time. Safety training may be presented by a knowledgeable supervisor, other department personnel or by representatives from other relevant sources. Regardless of the instructor, all safety training must be documented using the "Safety Training Attendance Record" or an equivalent record. By law, this documentation must be retained by the department for at least five years.

##### 4.1. Initial Training

The objective of training is to ease the implementation of health and safety policies into specific job practices and to raise awareness and skill levels to an acceptable standard. While all employees can benefit from health and safety training, special attention should be given to the training of supervisors, trainers, and workers.

When an employee is being trained on new assignments all safety features prescribed in conducting the procedure involved becomes an integral part of the training. The trainer is directly responsible for health and safety matters that are incorporated into the procedure.

Occasions when employee training may be required are:

- commencement of employment
- reassignment or transfer to a new job
- introduction of new equipment, processes, or procedures
- inadequate performance

Training will also be provided on how to report unsafe conditions, how to access the Safety Committee, and where to obtain information on workplace safety and health issues.

##### 4.2. Training on Specific Hazards

Supervisors are required to be trained on the hazards to which the employees under their immediate control may be exposed. This training aids a supervisor in understanding and enforcing proper protective measures.

All supervisors must ensure that the personnel they supervise receive appropriate training on the specific hazards of work they perform, and the proper precautions for protection against those hazards. Training is particularly important for new employees and whenever a new hazard is introduced into the workplace. Such hazards may include new equipment, hazardous materials, or procedures. Health and Safety training is also required when employees are given new job assignments on which they have not previously been trained and whenever a supervisor is made aware of a new or previously unrecognized hazard.

Specific topics which may be appropriate to department personnel include but are not limited to the following:

- Understanding Safety Data Sheet (SDS).
- Fire prevention techniques and fire extinguisher use.
- Obtaining emergency medical assistance and first aid.
- Disaster preparedness and response, including building evacuation procedures.
- Health and safety for computer users.
- Back care, body mechanics, and proper lifting techniques .
- Hazard communication, including training on SDSs, chemical hazards and container labeling.
- Proper Laboratory housekeeping.

## EMAX ORGANIZATION & MANAGEMENT

### B-5 Health & Safety Practices

---

- Chemical spill reporting procedures.

All training are documented in the safety training record.

#### 4.3. Safety Videos

A list of workplace safety videos can be obtained by contacting health and safety officer. Videos are available on a wide range of topics, including hazard communication, chemical safety, and various physical hazards. Videos should be used to supplement, not replace, face-to-face safety instruction, so that trainees have an opportunity to ask questions of a knowledgeable instructor.

#### 4.4. Safety Data Sheets

Safety Data Sheets (SDSs) provide information on the potential hazards of products or chemicals. Hard copies of SDSs for the chemicals used in the department are available in 3-ring binders located at the sample receiving area. If an SDS is found to be missing, a new one can be obtained by faxing a written request to the manufacturer. A copy of this request should be kept until the SDS arrives. In addition, SDS can be obtained in the Health and Safety browser. Understanding the use of SDS is also detailed in the EMAX browser and in the Chemical Hygiene plan.

#### 4.5. Equipment Operating Manuals

All equipment is to be operated in accordance with the manufacturer's instructions, as specified in the equipment's operating manual. Copies of operating manuals should be kept with each piece of equipment in the department. Persons who are unfamiliar with the operation of a piece of equipment and its potential hazards must read the operating manual before using the equipment and demonstrate equipment proficiency to their supervisors.

#### 4.6. Globally Harmonized System (GHS) Training

GHS is an international approach to hazard communication, providing agreed criteria for classification of chemical hazards, and a standardized approach to label elements and safety data sheets. The GHS was negotiated in a multi-year process by hazard communication experts from many different countries, international organizations, and stakeholder groups. It is based on major existing systems around the world, including OSHA's Hazard Communication Standard and the chemical classification and labeling systems of other US agencies.

The definitions of hazard have been changed to provide specific criteria for classification of health and physical hazards, as well as classification of mixtures. These specific criteria will help to ensure that evaluations of hazardous effects are consistent across manufacturers, and that labels and safety data sheets are more accurate as a result.





## EMAX ORGANIZATION & MANAGEMENT

### B-5 Health & Safety Practices

#### 4.6.1. Labeling

OSHA is requiring that employees are trained on the new label elements (i.e, pictograms, hazard statements, precautionary statements, and signal words)

|  |   |  |
|--|---|--|
| <b>2</b>  | <b>1</b> <b>Sulfuric Acid</b>   | <b>2</b>  |
|  | <b>3</b> <b>Danger! May be harmful if swallowed. Causes sever skin burns and eye damage. Fatal if inhaled. Harmful to aquatic life.</b>   |  |
|  | Do not breathe dust/fume/gas/mist/vapors/spray. Wear protective gloves/protective clothing/eye protection/face protection. Wear respiratory protection.                                       |  |
| <b>5</b>   | <b>IF IN EYES: Rinse cautiously with water for several minutes. Remove contact lenses, if present and easy to do. Continue rinsing. Immediately call a POISON CENTER or doctor/physician.</b> |  |
|  | <b>In case of fire Use water spray, alcohol-resistant foam, dry chemical or carbon dioxide.</b>   |  |
|  | See Material Safety Data Sheet for further details regarding safe use of this product.  |  |
| <b>6</b>   | Sigma-Aldrich 3050 Spruce Street SAINT LOUIS MO 63103 USA Telephone : +18003255832  |  |
| <b>1</b>   | Product Identifier  | <b>4</b> Hazard Statements   |
| <b>2</b>   | Pictograms  | <b>5</b> Precautionary Statements  |
| <b>3</b>   | Signal word, "Danger!"  | <b>6</b> Supplier Information  |

#### 4.6.2. Safety Data Sheets (SDS)

- The Hazard Communication Standard (HCS) requires chemical manufacturers, distributors, or importers to provide Safety Data Sheets (SDSs) (formerly known as Material Safety Data Sheets or MSDSs) to communicate the hazards of hazardous chemical products. As of June 1, 2015, the HCS will require new SDSs to be in a uniform format, and include the section numbers, the headings, and associated information under the headings below:
- **Section 1, Identification** includes product identifier; manufacturer or distributor name, address, phone number; emergency phone number; recommended use; restrictions on use.
- **Section 2, Hazard(s) identification** includes all hazards regarding the chemical; required label elements.
- **Section 3, Composition/information on ingredients** includes information on chemical ingredients; trade secret claims.
- **Section 4, First-aid measures** includes important symptoms/ effects, acute, delayed; required treatment.
- **Section 5, Fire-fighting measures** lists suitable extinguishing techniques, equipment; chemical hazards from fire.
- **Section 6, Accidental release measures** lists emergency procedures; protective equipment; proper methods of containment and cleanup.
- **Section 7, Handling and storage** lists precautions for safe handling and storage, including incompatibilities.

## EMAX ORGANIZATION & MANAGEMENT

### B-5 Health & Safety Practices

---

- **Section 8, Exposure controls/personal protection** lists OSHA's Permissible Exposure Limits (PELs); Threshold Limit Values (TLVs); appropriate engineering controls; personal protective equipment (PPE).
- **Section 9, Physical and chemical properties** lists the chemical's characteristics.
- **Section 10, Stability and reactivity** lists chemical stability and possibility of hazardous reactions.
- **Section 11, Toxicological information** includes routes of exposure; related symptoms, acute and chronic effects; numerical measures of toxicity.
- **Section 12, Ecological information\***
- **Section 13, Disposal considerations\***
- **Section 14, Transport information\***
- **Section 15, Regulatory information\***
- **Section 16, Other information**, includes the date of preparation or last revision.

## EMAX ORGANIZATION & MANAGEMENT

### B-5 Health & Safety Practices

---

#### 5.0 INJURY & ILLNESS PREVENTION PROGRAM (IIPP)

##### 5.1. Identifying Workplace Hazards

Regular, periodic workplace safety inspections must be conducted throughout the department by the Safety Officer or his representative. By law, the first of these inspections must take place when the IIPP is first adopted. The inspections should be documented, and copies of this documentation must be retained by the Health and Safety officer for at least one year. These regular inspections will be supplemented with additional inspections whenever new substances, processes, procedures, or equipment introduced into the workplace represent a new occupational safety and health hazard or whenever supervisors are made aware of a new or previously unrecognized hazard.

Supervisors are responsible for identification and correction of hazards that their staff face and should ensure that work areas they exercise control over are inspected at least annually. Supervisors should check for safe work practices with each visit to the workplace and should provide immediate verbal feedback where hazards are observed.

The "Report of Unsafe Condition" Form should be filled out when a referral is made to the Safety Committee as a result of a condition discovered during an inspection for which the responsible supervisor could not determine an immediate remedy. The "Report of Unsafe Condition" form can also be downloaded from the Health and Safety Browser, filled out and turned to the Safety Officer. No signature is necessary.

##### 5.2. Communicating Workplace Hazards

Supervisors are responsible for communicating with workers about safety and health issues. All department personnel are encouraged to communicate safety concerns to their supervisor without fear of reprisal.

The Safety Committee is another resource for communication regarding health and safety issues for department employees. Each employee has a representative on the committee that will inform him or her of hazard corrections and committee activities. Additionally, Safety Committee minutes and other safety-related items are posted in the lunchroom bulletin board. Employees will also be informed about safety matters by distribution of written memoranda, or by attendance of safety meetings. Occasionally, the Safety Committee may also sponsor seminars or speakers or coordinate other means to communicate with employees regarding health and safety matters.

Supervisors are responsible for ensuring that employees are supplied access to hazard information pertinent to their work assignments. Information concerning the health and safety hazards of tasks performed by department staff is available from a number of sources. These sources include, but are not limited to, Safety Data Sheets (SDSs, see below), equipment operating manuals, the Department Safety Coordinator, HEALTH AND SAFETY, container labels and work area postings.

##### 5.3. Correcting Workplace Hazards

Hazards discovered either as a result of a scheduled periodic inspection or during normal operations must be corrected by the supervisor in control of the work area, or by cooperation between the department in control of the work area and the supervisor of the employees working in that area. Supervisors of affected employees are expected to correct unsafe conditions as quickly as possible after discovery of a hazard, based on the severity of the hazard.

Specific procedures that can be used to correct hazards include but are not limited to the following:

- Tagging unsafe equipment "Do Not Use Until Repaired," and providing a list of alternatives for employees to use until the item is repaired.
- Stopping unsafe work practices and providing retraining on proper procedures before work resumes.



## EMAX ORGANIZATION & MANAGEMENT

### B-5 Health & Safety Practices

---

- Reinforcing and explaining the need for proper personal protective equipment and ensuring its availability and use.
- Barricading areas that have chemical spills or other hazards and reporting the hazardous conditions to a supervisor or Building Coordinator.

Supervisors should use the "Hazard Correction Report" to document corrective actions, including projected and actual completion dates. If necessary, supervisors can seek assistance in developing appropriate corrective actions by submitting a "Report of Unsafe Condition" to the Safety Committee. If the Safety Committee requires assistance from Health and Safety Officer, or Operations Manager these resources should be contacted immediately.

If an imminent hazard exists, work in the area shall cease, and the appropriate supervisor must be contacted immediately. If the hazard cannot be immediately corrected without endangering employees or property, all personnel need to be removed from the area except for those qualified and necessary to correct the condition. These qualified individuals will be equipped with necessary safeguards before addressing the situation.

#### 5.4. Investigating Injuries And Illnesses

##### 5.4.1. Injury Reporting

Employees who are injured at work must report the injury immediately to their supervisor. If immediate emergency medical treatment beyond first aid is needed, dial 9-911. The injured party will be taken to the appropriate hospital or medical center. If non-emergency medical treatment for work-related injuries or illnesses is needed, obtain treatment authorization form and go to Kaiser Permanente On-the-Job South Bay Medical Offices 18600 S. Figueroa Street, Suite 120 Gardena, CA 90248. Phone: 310-527-5600.

The supervisor of the injured employee must work with the department's safety coordinator to ensure that the "Employer's Report of Occupational Injury or Illness" and a "Workers' Compensation Claim Form" are completed properly and submitted to the Human Resources Department.

If the injured employee saw a physician, the supervisor shall obtain a medical release form before allowing the employee to return to work. The health care provider may stipulate work tasks that must be avoided or work conditions that must be modified before the employee resumes his or her full duties.

##### 5.4.2. Injury Investigation

The injured employee's supervisor is responsible for performing an investigation to determine and correct the cause(s) of the incident. Specific procedures that can be used to investigate workplace accidents and hazardous substance exposures include:

- Interview the injured personnel and witnesses
- Examine the injured employee's workstation for causative factors
- Review the established procedures to ensure they are adequate and were followed by the employee.
- Review training records of injured employees.
- Determine all contributing causes to the accident.
- Take corrective actions to reduce potential for similar accident/exposure from reoccurring.
- Record all findings and actions taken involving the injury.

## EMAX ORGANIZATION & MANAGEMENT

### B-5 Health & Safety Practices

---

The supervisor's findings and corrective actions should be documented and presented to the Safety Committee using the "Occupational Accident, Injury or Illness Investigation Report". If the supervisor is unable to determine the cause(s) and appropriate corrective actions, other resources should be sought. Available resources include the department's Safety Committee and the Safety Officer.

The Safety Committee will review each accident or injury report to ensure that the investigation was thorough and that all corrective actions are completed. Investigations and/or corrective actions that are found to be incomplete will be routed back to the supervisor for further follow-up, with specific recommendations noted by the committee. The Department Safety Coordinator will bring corrective actions that are not implemented in a reasonable period of time to the attention of the Safety Officer and/or Operation Manager.

## EMAX ORGANIZATION & MANAGEMENT

### B-5 Health & Safety Practices

---

#### 6.0 EMERGENCY PROCEDURES

Emergency procedures are plans for dealing with emergencies such as fires, explosions, major releases of hazardous materials, violent occurrences, or natural hazards. When such events occur, the urgent need for rapid decisions, shortage of time, lack of resources, and trained personnel can lead to major confusion. The objective of the plan is to prevent or minimize fatalities, injuries, and damage. The organization and procedures for handling these sudden and unexpected situations must be clearly defined.

##### 6.1. Emergency Fire Procedures

- Sound the alarm. Activate the fire alarm as soon as you find or suspect a fire.
- Exit Immediately. Leave the building. As you leave, warn other occupants by knocking on doors and shouting. Refer to Figure 1 for Emergency Evacuation Route.
- In case the stairs are needed, go to the nearest stairway or exit. Stairway doors--if closed--will keep out fire and smoke and protect you until you are outside.
- If heat, fire or smoke blocks the nearest exit, stay low and go to another exit.
- Stay out of the building until given the OK to return by fire officials.
- Call 911. Report the emergency from a safe location. Dial 9-911 from an EMAX phone or 911 from a cellular phone if available. Provide the dispatcher with as much information as possible.

##### 6.1.1. Fighting a Fire

If the fire is very small, and you know how to use a fire extinguisher safely, you may attempt to put out the fire. Make sure the fire department has been called first! Be sure you have the right fire extinguisher for the type of fire you are attempting to fight. Using the wrong type of extinguisher may make the fire worse. Do not let the fire get between you and your exit route. Stay between the fire and the door. If one extinguisher does not put out the fire, get out immediately, closing the door behind you.

##### 6.1.2. Types of Fire Extinguishers Used in the Laboratory

Fire extinguishers are categorized by the type of fires they put out:

- Type A--Ordinary combustibles such as wood, paper, cloth, rubber, and plastics.
- Type B--Flammables liquids such as gasoline, oils, paints, and grease.
- Type C--Electrical fire such as burning wires, switches, machinery, and appliances.

Fire extinguishers will have a label indicating what type of fire they can extinguish. Extinguishers found in the laboratory are ABC extinguishers and can fight all three kinds of fires. Using the wrong extinguisher can be dangerous. For example, using a Type A extinguisher on a Type B fire (burning liquid) can cause the liquid to dissipate, spreading the fire. If you're not sure about either the type of fire or the type of extinguisher, wait for the fire department.

##### 6.1.3. Using a Fire Extinguisher

If you know you have the right extinguisher and the fire is small enough to fight safely, remember the PASS acronym, to use your extinguisher effectively:

- Pull the safety pin at the top of the extinguisher.
- Aim the nozzle, horn, or hose at the base of the flames.
- Squeeze the handle of the extinguisher.
- Sweep the nozzle from side to side until the fire goes out.

## EMAX ORGANIZATION & MANAGEMENT

### B-5 Health & Safety Practices

---

#### 6.1.4. Fire Safety Tips

- Know your exits. There is a fire exit path in every department. Be familiar with it.
- Keep your exit paths clear.
- Know where the nearest fire alarm and fire extinguisher are.
- Remember - extension cords are for temporary power only.
- Participate in fire drills.
- Observe no smoking postings.

#### 6.2. Emergency Procedures For Chemical Spillage

##### 6.2.1. Organic Solvent

- Eliminate all sources of ignition and instruct others to keep at a safe distance, well away from the spillage area.
- Open windows if possible and close laboratory doors on the way out. Aim to ventilate the area but isolate the material.
- Decide whether to control the spillage on site, or to evacuate the building by sounding the fire alarm and calling in the local fire brigade.
- Wear a laboratory coat or protective organic solvent proof overall, organic solvent proof rubber gloves, eye and/or face protection and air purifying respirator.
- Dispose spill clean up according to CHP section 3.5 – 3.6.

##### 6.2.2. Inorganic acids

- Eliminate all sources of ignition and instruct others to keep at a safe distance, well away from the spillage area.
- Open windows if possible and close laboratory doors on the way out. Aim to ventilate the area but isolate the material.
- Decide whether to control the spillage on site, or to evacuate the building by sounding the fire alarm and calling in the local fire brigade.
- Wear a laboratory coat or protective acid-proof overall, acid-proof rubber gloves, eye and/or face protection and air purifying respirator.
- Dispose spill clean up according to CHP Section 3.5 – 3.6.

##### 6.2.3. Alkalis - Note that these compounds may react violently with water.

- Eliminate all sources of ignition and instruct others to keep at a safe distance, well away from the spillage area.
- Open windows if possible and close laboratory doors on the way out. Aim to ventilate the area but isolate the material.
- Decide whether to control the spillage on site, or to evacuate the building by sounding the fire alarm and calling in the local fire brigade.
- Wear a laboratory coat, protective gloves, eye and/or face protection and air purifying respirator.
- Dispose spill clean up according to CHP section 3.5 – 3.6.

## EMAX ORGANIZATION & MANAGEMENT

### B-5 Health & Safety Practices

---

#### 6.2.4. Mercury Spills

Mercury spills should be cleaned up immediately and treated as any other hazardous chemical waste.

#### 6.3 Electrical Safety Guidelines

The danger of injury through electric shock is possible whenever electrical power is present. When a person's body completes a circuit and thus connects a power source with the ground, an electrical burn or injury is imminent. Most fatal injuries result from high voltage exposure; however, people can sustain severe injuries from low voltage power if it has a high current flow. In addition, overloaded circuits and poorly maintained electrical equipment and connections can lead to fires. Electrical fires are also capable of causing injuries and usually result in significant damage to facilities.

##### 6.3.1 General Electrical Safety

Electrical safety is important in every laboratory and office. Follow these guidelines for general electrical safety:

- Be familiar with the electrical hazards in your laboratory or office.
- Be familiar with electrical emergency response procedures.
- Unplug electrical equipment before repairing or servicing.
- DO NOT work on electrical equipment unless you are qualified to do so. This includes changing electrical plugs on equipment.
- Inspect cords and plugs for defects such as frayed wiring, loose connections or cracked insulation. Repair or replace items, which exhibit these defects.
- Ensure that all outlets are firmly mounted and in good condition.
- Report all electrical problems (tripped breakers, broken switches and flickering lights) to the Safety Officer or the Facility Manager.
- Keep electrical equipment and appliances away from water.
- Avoid overloading circuits--if possible only plug a single appliance into an outlet.
- If multiple appliances are necessary, use an approved UL listed power strip that has a surge protector and a circuit breaker.
- Ensure that all electrical equipment have grounded plugs (3-prong for 110/208V single phase and 4-prong for any 3-phase system).
- Keep electric cords away from areas where they may be pinched and areas where they may pose a tripping or fire hazard (i.e. door ways, walkways, under carpet, etc.).

##### 6.3.2 Extension Cords

Extension cords should only be used on a temporary basis and are not to be used in place of permanent wiring. If work requires using equipment or appliances in areas where there are not enough outlets, a request for additional installation of outlets from the department supervisor as needed.

Ensure that all extension cords are correct by size and rated for the equipment in use. The diameter of the extension cord should be the same or greater than the cord of the equipment. If you are unsure about the rating of an extension cord, contact the Safety Officer or the Facility Manager for advice.

##### 6.3.3 Electrical Panels

Electrical panels or breaker boxes require special safety considerations, including the following:

## EMAX ORGANIZATION & MANAGEMENT

### B-5 Health & Safety Practices

---

- Know the location of the electrical panel in your work area.
- Do not block access to the panel with furniture or equipment. You must maintain a 36 " clearance in front of the panel to provide unobstructed access.
- Never tape circuit switches to keep a breaker from tripping.
- Ensure that breakers are accurately labeled within panel boxes.
- Ensure that the panel door is securely attached.
- Report tripped breakers to Facility Manager.

#### 6.3.4 Electrical Emergency Response

All employees should be familiar with the following guidelines in case of electrical injury:

- If the victim is still in contact with the electric current, immediately turn off the power source.
- If you cannot disconnect the power source, try to separate or pry the victim away from the power source by using a non-conductive item such as a piece of dry wood or book.
- Never touch a victim still in contact with the power source; you could electrocute yourself.
- After removing the person from the power source, call 9-911 to summon medical help and administer first aid or CPR if you are trained to do so.



## EMAX ORGANIZATION & MANAGEMENT

### B-5 Health & Safety Practices

---

#### 7.0 HEALTH AND SAFETY PROGRAM EVALUATION

##### 7.1. General Inspection

A quarterly Health and Safety general audit shall be conducted to measure the effectiveness of the HEALTH AND SAFETY program. The audit uses a checklist in which each area of concern is checked for appropriateness and adequacy for a safe and healthy environment. Records, observations, interviews, and questionnaires are used to evaluate performance for each sub-element. The audit team includes representation from the joint health and safety committee, must receive appropriate training in audit procedures. The audit identifies weaknesses in the health and safety program as well as its strength. A procedure is also established to ensure prompt follow-up on deficiencies. This procedure must include provision for target dates for remedial action and checks to confirm completion.

##### 7.2. Self-Inspection

All laboratories are required to perform and document self-inspections on a quarterly basis. The self-inspection form will help document laboratory safety inspections and will assist laboratory personnel in identifying and correcting many common unsafe practices and conditions. The unsafe practices and conditions identified are prohibited by state laws or EMAX policies, or are not generally accepted safe laboratory practices. Findings shall be documented in the Laboratory Self-Inspection form.

A designated individual in each department must inspect the laboratory using this form and answer each question by checking Yes (Satisfactory), No (Needs Correction), or N/A (Not Applicable) if the question does not apply to the department. After completing the self-inspection form, results must be shared with the Supervisor, and the individual in the department.

Correct each identified deficiency as soon as possible and document correction on the form.

Inform the Operations Manager if assistance is needed in correcting conditions identified during the self-inspection, or if there are questions or concerns about laboratory safety, whether or not they pertain to this self-inspection.

Submit the original self-inspection form to the Health and Safety Officer for proper record keeping.

This checklist does not address specific activities involving radioactive materials or radiation-producing machines, which are separately inspected by the RSO or his designee.

#### 8.0 RECORD KEEPING

##### 8.1. Documents Maintained by Health and Safety Officer

By law, certain documents related to the HEALTH AND SAFETY must be kept by the safety officer and maintained

in accordance with contractual and regulatory requirements. These records include:

- Records of scheduled and periodic workplace inspections, including the persons conducting the inspection, any identified unsafe conditions or work practices, and corrective actions taken.
- Employee safety training records, including the names of all attendees and instructors, the training date, and material covered.
- Reports of Unsafe Conditions or Hazards.
- Safety Committee Meeting Documentation.
- Hazard Correction Reports.
- Accident, Injury or Illness Investigation Reports.

## **EMAX ORGANIZATION & MANAGEMENT**

### **B-5 Health & Safety Practices**

---

#### **9.0 Forms**

- 9.1. Report Of Unsafe Condition Or Hazard Form
- 9.2. Hazard Correction Report Form
- 9.3. Occupational Accident, Injury Or Illness Investigation Report Form
- 9.4. Safety Training Attendance Record Form
- 9.5. New Employee Safety Training Record Form
- 9.6. Health and Safety Orientation Form
- 9.7. Health and Safety Orientation Tour
- 9.8. Safety Committee Meeting Documentation Form
- 9.9. Laboratory Self-Inspection Form
- 9.10. General Self-Inspection Form
- 9.11. Emergency Evacuation Route
- 9.12. Location of Safety Material and Equipment



## EMAX ORGANIZATION & MANAGEMENT

### B-5 Health & Safety Practices

#### REPORT OF UNSAFE CONDITION OR HAZARD

|  |            |
|--|------------|
| <b>I. Unsafe Condition or Hazard</b>   |            |
| Name: (optional)   |            |
| Title:   | Department |
| Location of Hazard:  |            |
| Date and time the condition or hazard was observed:  |            |
| Description of unsafe condition or hazard:   |            |
| What changes would you recommend to correct the condition or hazard?   |            |
| Employee Signature: (optional)   | Date       |
| <b>II. Management/Safety Committee Investigation</b>   |            |
| Name of person investigating unsafe condition or hazard:   |            |
| Results of investigation (What was found? Was condition unsafe or a hazard?): (Attach additional sheets if necessary.) |            |
| Proposed action to be taken to correct hazard or unsafe condition:   |            |
| Signature of Investigating Party:  | Date:      |



## EMAX ORGANIZATION & MANAGEMENT

### B-5 Health & Safety Practices

#### OCCUPATIONAL ACCIDENT, INJURY OR ILLNESS INVESTIGATION REPORT

|  |       |       |
|--|-------|-------|
| Department:                                  |       |       |
| Supervisor's Name                            |       |       |
| Person(s) involved:                          |       |       |
| Location:                                    | Time: | Date: |
| Task being performed when accident occurred: |       |       |

**NOTE:** This form is intended to serve only as a local record of the investigation conducted within the department. Should an injury or illness occur, required forms must be submitted to the Human Resources Department. "Hazard Correction Report" must be completed in conjunction with any accident, injury or illness.

Describe the accident, illness, or injury and the probable root cause(s) of the incident. Include the nature of the injury or illness, any eyewitness accounts, and any property damage, which may have occurred. Be sure to include the names and phone numbers of any witnesses. Attach a separate sheet if necessary.

---

---

---

---

Describe what corrective actions need to be taken to ensure this type of incident does not recur. Also, include the name(s) and phone number(s) of those who will ensure that these corrective actions are done in a timely manner.

---

---

---

Signature of Supervisor Conducting Investigation

Date

Signature of Department Safety Coordinator

Date

(Do not sign until a thorough review of the incident by the Safety Committee is complete and corrective actions are in place.)



## EMAX ORGANIZATION & MANAGEMENT

### B-5 Health & Safety Practices

#### HEALTH AND SAFETY ORIENTATION FORM

EMPLOYEE NAME \_\_\_\_\_  
DEPARTMENT \_\_\_\_\_  
TITLE \_\_\_\_\_  
HIRE DATE \_\_\_\_\_

1. SAFETY TOUR

Date Completed \_\_\_\_\_ Employee Initials \_\_\_\_\_ Safety Rep's Initials \_\_\_\_\_

2. SAFETY AND HEALTH MANUAL (Reviewed marked Sections)

|                 |                   |                 |
|-----------------|-------------------|-----------------|
| _____ Section 1 | _____ Section 5.1 | _____ Section 6 |
| _____ Section 2 | _____ Section 5.2 | _____ Section 7 |
| _____ Section 3 | _____ Section 5.3 | _____ Section 8 |
| _____ Section 4 | _____ Section 5.4 | _____ Section 9 |

Date Reviewed \_\_\_\_\_ Employees Initials \_\_\_\_\_

3. PERSONAL PROTECTIVE EQUIPMENT

|                       |                       |
|-----------------------|-----------------------|
| _____ Safety Glasses  | _____ Ear Plugs       |
| _____ Rubber Gloves   | _____ Respirator      |
| _____ Laboratory Coat | _____ Other (Specify) |

Date Issued \_\_\_\_\_ Employees Initials \_\_\_\_\_

4. SAFETY AND HEALTH TRAINING REQUIRED

|                             |  |
|-----------------------------|--|
| _____ Right To Know         | _____ Confined Space Entry                         |
| _____ Respirator Protection | _____ Hazardous Waste Operation                    |
| _____ Asbestos              | _____ Manual Review (Indicate Applicable Sections) |

5. PHYSICALS REQUIRED

|                  |                                 |
|------------------|---------------------------------|
| _____ Asbestos   | _____ Hazardous Waste Operation |
| _____ Respirator | _____ Other (Specify)           |

Employees Signature \_\_\_\_\_ Safety Officer's Signature \_\_\_\_\_

Date \_\_\_\_\_ Date \_\_\_\_\_

## EMAX ORGANIZATION & MANAGEMENT

### B-5 Health & Safety Practices

---

HEALTH AND SAFETY ORIENTATION TOUR for \_\_\_\_\_

1. Building Tour: Layout of office areas and Laboratories.
2. Location of Health and Safety Manual: Review Chapter Headings.
3. First Aid Station: Mandatory Injury Reporting.
4. Safety Glasses Policy:
  - a. Arrange for temporary safety glasses.
  - b. Initiate paperwork for ordering safety glasses.
5. Location of lab coats and policy on use.
6. Safety features of each room/areas.
  - a. Fire extinguishers.
  - b. Emergency eyewash stations.
  - c. Emergency showers.
  - d. Emergency exits.
  - e. Telephones: paging system 59; emergency 9-911.
  - f. Chemical storage areas.
  - g. Gas cylinders.
  - h. Sample storage areas.
7. SDS Library: Located in the Safety Officer's room and online under SOP and internet.
8. Orientation to specific work station/area.
  - a. Introduction to co-workers.
  - b. Specific chemicals, handling procedures.
  - c. Equipment operation.
  - d. Waste disposal procedures.

Signature specifies that all items have been covered and the employee has been given the opportunity to ask questions.

Supervisor giving tour:

New employee:

\_\_\_\_\_  
Signature

\_\_\_\_\_  
Signature

\_\_\_\_\_  
Date

\_\_\_\_\_  
Date







## EMAX ORGANIZATION & MANAGEMENT

### B-5 Health & Safety Practices

#### LABORATORY INSPECTION FORM

This form is used to ensure compliance with Cal/OSHA regulations that require documented periodic inspections of all work areas as part of an effective IPP. However, completion of this self-inspection checklist and correction of any findings noted herein does not ensure that Cal/OSHA will not issue citations during an inspection. In addition, HEALTH AND SAFETY representatives will be periodically verifying that self-inspections have been documented as part of the Environmental Health & Safety Assessment program.

|                         |                        |
|-------------------------|------------------------|
| _____                   | _____                  |
| Lab Location            | Date of Inspection     |
| _____                   | _____                  |
| Print Supervisor's Name | Supervisor's Signature |
| _____                   | _____                  |
| Print Inspector's Name  | Inspector's Signature  |

#### GENERAL HAZARDS

- Are aisles, exits, and adjoining hallways maintained free of obstructions that would hinder emergency exiting?  
 Yes (Satisfactory)       No (Needs Correction)       N/A (Not Applicable)  
Corrective Action: Remove obstructions from aisles, exits, and adjoining hallways. Contact Safety Officer if help is needed cleaning adjoining hallways.  
Completion Date: \_\_\_\_\_.
- Is there at least 18 inches (47 cm) of vertical clearance maintained between all stored items and the ceiling-mounted fire sprinklers? (If there are no sprinklers, measure to the ceiling itself)  
 Yes (Satisfactory)       No (Needs Correction)       N/A (Not Applicable)  
Corrective Action: Remove stored items that do not meet the above criteria.  
Completion Date: \_\_\_\_\_.
- Is furniture and equipment over 4 feet tall bolted to the wall or otherwise secured?  
 Yes (Satisfactory)       No (Needs Correction)       N/A (Not Applicable)  
Corrective Action: Contact your Safety Officer for assistance in installing seismic restraints.  
Completion Date: \_\_\_\_\_.
- Are laboratory requirements for the use of personal protective equipment (such as gloves and goggles) established and enforced?  
 Yes (Satisfactory)       No (Needs Correction)       N/A (Not Applicable)  
Corrective Action: Establish written requirements for personal protective equipment. For work with hazardous chemicals, incorporate these in your Chemical Hygiene Plan.  
Completion Date: \_\_\_\_\_.
- Are sharps waste containers available for disposing of needles, blades, and other sharps, and have all laboratory personnel been instructed on proper sharps disposal?  
 Yes (Satisfactory)       No (Needs Correction)       N/A (Not Applicable)

## EMAX ORGANIZATION & MANAGEMENT

### B-5 Health & Safety Practices

---

Corrective Action: Purchase a sharps container if needed. Train all laboratory personnel to avoid bending, cutting, or re-capping syringe needles.

Completion Date: \_\_\_\_\_.

#### EMERGENCY EQUIPMENT

6. Are all eyewash and emergency shower stations free of obstructions which would prevent quick access by someone temporarily blinded by a chemical splash?

Yes (Satisfactory)       No (Needs Correction)  N/A (Not Applicable)

Corrective Action: Remove all obstructions from emergency eyewashes and showers.

Completion Date: \_\_\_\_\_.

7. Are the emergency eyewashes for your laboratory tested (flushed) monthly, with the tests documented?

Yes (Satisfactory)       No (Needs Correction)  N/A (Not Applicable)

Corrective Action: Assign a laboratory employee to test all emergency eyewashes monthly. Document each test in a logbook or on an attached tag. Inform the Facility Manager if repairs are needed.

Completion Date: \_\_\_\_\_.

#### FLAMMABLE MATERIALS

8. Does the total quantity of flammable liquids stored in the laboratory comply with each of the following?

- The number of one (1) gallon glass containers stored outside storage cabinets must not exceed ten (10).
- The number of one (1) gallon safety cans in use outside storage cabinets must not exceed ten (10). The number of two (2) gallon safety cans must not exceed five (5).
- Total quantity of flammable liquids stored in the laboratory must be less than 30 gallons.

Yes (Satisfactory)       No (Needs Correction)  N/A (Not Applicable)

Corrective Action: Reduce the quantity of stored flammable liquids to meet the above criteria. Consult with the Safety Officer if assistance is needed.

Completion Date: \_\_\_\_\_.

9. Are the doors on all flammables storage cabinets self-closing?

Yes (Satisfactory)       No (Needs Correction)  N/A (Not Applicable)

Corrective Action: Consult with the Department Supervisor for assistance in ordering and installing self-closing mechanisms.

Completion Date: \_\_\_\_\_.

10. Are all refrigerators and freezers in the laboratory labeled with "NO FOOD"?

Yes (Satisfactory)       No (Needs Correction)  N/A (Not Applicable)

Corrective Action: Consult with the Department Supervisor for assistance in determining if refrigerators are suitable for flammables storage, and to obtain labels.

Completion Date: \_\_\_\_\_.

#### HAZARDOUS CHEMICALS

11. Does your laboratory have a new revised or reviewed Chemical Hygiene Plan that has been completed or updated within the last year?

Yes (Satisfactory)       No (Needs Correction)  N/A (Not Applicable)

## EMAX ORGANIZATION & MANAGEMENT

### B-5 Health & Safety Practices

---

**Corrective Action:** Contact your Safety Officer if you need a Chemical Hygiene Plan template. Assign a Chemical Hygiene Officer for the laboratory and have them read, fill out, and follow the guidance in the template. Post the Plan by the telephone.

Completion Date: \_\_\_\_\_.

12. Has documented training on the Chemical Hygiene Plan been provided to all laboratory workers?

Yes (Satisfactory)       No (Needs Correction)  N/A (Not Applicable)

**Corrective Action:** Ensure that all workers have read and signed the Plan. Consult with the Safety Officer with any questions.

Completion Date: \_\_\_\_\_.

13. Has a chemical inventory of all hazardous materials in the laboratory been completed or revised within the last year and forwarded to HEALTH AND SAFETY? Date of last Chemical Inventory \_\_\_\_\_.

Yes (Satisfactory)       No (Needs Correction)  N/A (Not Applicable)

**Corrective Action:** Complete and update the Chemical Inventory. . Consult with the Safety Officer if you need assistance in preparing an inventory.

Completion Date: \_\_\_\_\_.

14. Are food and beverages prohibited from laboratory work areas?

Yes (Satisfactory)       No (Needs Correction)  N/A (Not Applicable)

**Corrective Action:** Remove food and beverage items and reinforce this rule.

Completion Date: \_\_\_\_\_.

#### CHEMICAL STORAGE

15. Are all laboratory countertops, floors, and equipment maintained free of spilled hazardous materials and removable chemical residues?

Yes (Satisfactory)       No (Needs Correction)  N/A (Not Applicable)

**Corrective Action:** Clean up any spilled material. . Consult with the Safety Officer for assistance if needed.

Completion Date: \_\_\_\_\_.

16. Are chemical fume hoods kept uncluttered so that air flows properly (e.g. storage minimized and adequate usable work area provided)? Are chemical fume hood sashes in good condition, and used at the proper setting?

Yes (Satisfactory)       No (Needs Correction)  N/A (Not Applicable)

**Corrective Action:** Train laboratory occupants to minimize hood clutter and place sashes to maintain good airflow and provide splash protection. Inform Facilities Manager for repairs.

Completion Date: \_\_\_\_\_.

17. Are all sinks labeled with "No Hazardous Chemicals" stickers, and are all laboratory personnel aware of the EMAX Drain Disposal Guidelines?

Yes (Satisfactory)       No (Needs Correction)  N/A (Not Applicable)

**Corrective Action:** Consult with the Safety Officer for additional stickers.

## EMAX ORGANIZATION & MANAGEMENT

### B-5 Health & Safety Practices

---

Completion Date: \_\_\_\_\_.

18. Are all chemical containers kept closed when not in use, to avoid the evaporation of volatile materials?

Yes (Satisfactory)       No (Needs Correction)       N/A (Not Applicable)

Corrective Action: Train all laboratory occupants to keep chemical containers closed when not in use.

Completion Date: \_\_\_\_\_.

19. Are all chemical containers clearly labeled to identify their contents and in good condition (not corroded or leaking)?

Yes (Satisfactory)       No (Needs Correction)       N/A (Not Applicable)

Corrective Action: Label all chemical containers, replacing those that are corroded or leaking.

Completion Date: \_\_\_\_\_.

20. Are stored chemicals segregated by hazard class (acids separate from bases, oxidizers separate from flammables, etc.)?

Yes (Satisfactory)       No (Needs Correction)       N/A (Not Applicable)

Corrective Action: Segregate chemicals by hazard class. Consult with the Safety Officer for assistance with chemical segregation.

Completion Date: \_\_\_\_\_.

21. Are one gallon (4-liter) and larger containers of hazardous chemicals stored in secondary containment?

Yes (Satisfactory)       No (Needs Correction)       N/A (Not Applicable)

Corrective Action: Provide secondary containment such as chemically-resistant tubs or coated bottles.

Completion Date: \_\_\_\_\_.

22. Are corrosive chemicals stored below eye level to prevent accidental injury?

Yes (Satisfactory)       No (Needs Correction)       N/A (Not Applicable)

Corrective Action: Relocate corrosives to a location below eye level.

Completion Date: \_\_\_\_\_.

23. Are peroxide formers (such as diethyl ether) stored away from light or heat, and labeled with the date they were opened and their expiration date?

Yes (Satisfactory)       No (Needs Correction)       N/A (Not Applicable)

Corrective Action: Label all peroxide formers with the opening date and expiration date. These chemicals may become explosive after prolonged storage. If any of these chemicals are present and have not been used for a long time, do not handle them. Consult with the Safety Officer and ask for assistance.

Completion Date: \_\_\_\_\_.

#### ELECTRICAL EQUIPMENT

24. Are extension cords and power strips in good condition (e.g., no breaks or exposed wiring), used only as temporary wiring (<30 days), and not connected in series?

Yes (Satisfactory)       No (Needs Correction)       N/A (Not Applicable)

## EMAX ORGANIZATION & MANAGEMENT

### B-5 Health & Safety Practices

---

**Corrective Action:** Dispose of or repair all electrical cords that are not in good condition. Remove all daisy chained or permanent use power strips and extension cords. Inform the Facilities Manager for installation of permanent wiring.

Completion Date: \_\_\_\_\_.

25. Is high voltage equipment clearly labeled, properly guarded, and is its use restricted to only trained personnel?

Yes (Satisfactory)       No (Needs Correction)  N/A (Not Applicable)

**Corrective Action:** Label all high voltage equipment with appropriate warnings. Restrict use of this equipment to properly trained personnel.

Completion Date: \_\_\_\_\_.

#### OTHER EQUIPMENT

26. Are all compressed gas cylinders adequately secured with non-combustible restraints to keep the cylinder(s) from falling during an earthquake? (If chains are used, two should be present for each cylinder.) Also, are all compressed gas cylinders capped when not in use?

Yes (Satisfactory)       No (Needs Correction)  N/A (Not Applicable)

**Corrective Action:** Inform Facilities Manger for assistance in installing gas cylinder restraints. Bench clamps are not allowed. In addition, train laboratory occupants to cap compressed gas cylinders when not in use.

Completion Date: \_\_\_\_\_.

27. Are all refrigerators and microwave ovens properly labeled either "food only" or "no food"?

Yes (Satisfactory)       No (Needs Correction)  N/A (Not Applicable)

**Corrective Action:** Label all refrigerators and microwave ovens as "food only" or "no food".

Completion Date: \_\_\_\_\_.

#### OTHER HAZARDS

28. List any other hazardous conditions in need of correction that are not mentioned in this checklist. Assign and document correction of each item listed below.

1. \_\_\_\_\_

2. \_\_\_\_\_

## EMAX ORGANIZATION & MANAGEMENT

### B-5 Health & Safety Practices

#### GENERAL INSPECTION FORM

|                         |                        |
|-------------------------|------------------------|
| Office Location         | Date of Inspection     |
| Print Supervisor's Name | Supervisor's Signature |
| Print Inspector's Name  | Inspector's Signature  |

1. Is the Cal/OSHA poster "Safety and Health Protection on the Job" displayed in the building in an area accessible to all employees?  
 Yes (Satisfactory)       No (Needs Correction)       N/A (Not Applicable)  
Corrective Action: Contact Health and Safety Officer to obtain posters.  
Completion Date: \_\_\_\_\_.
2. Is documentation of safety training, workplace self-inspections, and hazard corrections maintained and accessible where indicated in your department's IIPP?  
 Yes (Satisfactory)       No (Needs Correction)       N/A (Not Applicable)  
Corrective Action: Confirm location listed in the IIPP and ensure that records are stored there.  
Completion Date: \_\_\_\_\_.
3. Have employees in the area been trained on the applicable Building Emergency Plan (BEP)?  
 Yes (Satisfactory)       No (Needs Correction)       N/A (Not Applicable)  
Corrective Action: Contact the Safety Officer to obtain the BEP, or contact your Building Coordinator if a BEP is not available.  
Completion Date: \_\_\_\_\_.
4. Are evacuation diagrams posted?  
 Yes (Satisfactory)       No (Needs Correction)       N/A (Not Applicable)  
Corrective Action: Contact the Department Safety Coordinator, Building Coordinator, or HEALTH AND SAFETY for assistance in preparing diagrams as required by the BEP.  
Completion Date: \_\_\_\_\_.
5. Are fire alarm pull boxes clearly identifiable and unobstructed?  
 Yes (Satisfactory)       No (Needs Correction)       N/A (Not Applicable)  
Corrective Action: Clear area of obstructions.  
Completion Date: \_\_\_\_\_.
6. Are fire hose stations and/or portable extinguishers clearly identifiable and unobstructed?  
 Yes (Satisfactory)       No (Needs Correction)       N/A (Not Applicable)  
Corrective Action: Label fire-fighting equipment and clear area of obstructions.



## EMAX ORGANIZATION & MANAGEMENT

### B-5 Health & Safety Practices

---

Completion Date: \_\_\_\_\_.

7. Are fire extinguishers tagged with current annual inspections?

Yes (Satisfactory)       No (Needs Correction)  N/A (Not Applicable)

Corrective Action: Call 800-841-9696 to arrange for a fire extinguisher inspection by H&P Fire Extinguisher Co. Ensure that the extinguisher is properly tagged after the inspection.

Completion Date: \_\_\_\_\_.

8. Do self-closing devices and door latches on fire-rated doors work freely? (Doorstops are not permitted.)

Yes (Satisfactory)       No (Needs Correction)  N/A (Not Applicable)

Corrective Action: Contact your Safety Officer to arrange for door repairs.

Completion Date: \_\_\_\_\_.

9. Are there at least 18 inches (47 cm) of vertical clearance maintained between all stored items and any ceiling equipped with fire sprinklers?

Yes (Satisfactory)       No (Needs Correction)  N/A (Not Applicable)

Corrective Action: Remove stored items that do not meet the above criteria.

Completion Date: \_\_\_\_\_.

10. Are electrical panels accessible and circuit breakers clearly identified?

Yes (Satisfactory)       No (Needs Correction)  N/A (Not Applicable)

Corrective Action: Label circuit breakers as to their function, and clear area in front of electrical panels by 36 inches.

Completion Date: \_\_\_\_\_.

11. Are aisles, exits, and adjoining hallways maintained free of obstructions so that the area can be easily evacuated or accessed in case of an emergency?

Yes (Satisfactory)       No (Needs Correction)  N/A (Not Applicable)

Corrective Action: Remove obstructions from aisles, exits, and adjoining hallways. Contact Safety Officer if help is needed cleaning adjoining hallways.

Completion Date: \_\_\_\_\_.

12. Are electrical equipment (e.g., copiers and computers) grounded? (Ensure that the grounding prong has not been removed, and that 3-prong to 2-prong adapters are not used.)

Yes (Satisfactory)       No (Needs Correction)  N/A (Not Applicable)

Corrective Action: Contact your supervisor or Safety Officer to arrange for installation of appropriate outlets and plugs.

Completion Date: \_\_\_\_\_.

13. Are extension cords in good condition (e.g., no breaks or exposed wiring), used only as temporary wiring (less than 30 days), and not connected in series?

Yes (Satisfactory)       No (Needs Correction)  N/A (Not Applicable)

## EMAX ORGANIZATION & MANAGEMENT

### B-5 Health & Safety Practices

---

**Corrective Action:** Do not connect extension cords in series. Dispose of or repair all electrical cords that are not in good condition, and replace those in use more than 30 days with permanent wiring.

**Completion Date:** \_\_\_\_\_.

14. Is broken, unguarded, or otherwise dangerous equipment or furniture present? (Example: A paper cutter without a guard to keep fingers away from the blade.)

Yes (Satisfactory)       No (Needs Correction)  N/A (Not Applicable)

**Corrective Action:** Contact your supervisor or Safety Officer to arrange for removal or repair of equipment or furniture.

**Completion Date:** \_\_\_\_\_.

15. Are floor surfaces kept dry and/or made slip-resistant?

Yes (Satisfactory)       No (Needs Correction)  N/A (Not Applicable)

**Corrective Action:** Work with your supervisor or Safety Officer or Safety Committee to address this issue.

**Completion Date:** \_\_\_\_\_.

16. Is furniture and equipment over 4 feet tall braced to prevent tipping in an earthquake?

Yes (Satisfactory)       No (Needs Correction)  N/A (Not Applicable)

**Corrective Action:** Contact your supervisor or Safety Officer for assistance in installing seismic restraints, or remove all of items in question.

**Completion Date:** \_\_\_\_\_.

17. Are all work areas adequately illuminated?

Yes (Satisfactory)       No (Needs Correction)  N/A (Not Applicable)

**Corrective Action:** Contact your supervisor or Safety Officer for assistance in obtaining additional lighting.

**Completion Date:** \_\_\_\_\_.

18. Have computer workstations been ergonomically evaluated for all employees who spend 4 or more hours at their computer each day?

Yes (Satisfactory)       No (Needs Correction)  N/A (Not Applicable)

**Corrective Action:** Contact your supervisor or Safety Officer to have a trained workstation evaluator assess the workstation. If you department does not have an evaluator, contact the Safety Officer.

**Completion Date:** \_\_\_\_\_.

19. Are emergency back up lights in proper working conditions?

Yes (Satisfactory)       No (Needs Correction)  N/A (Not Applicable)

**Corrective Action:** Contact your supervisor or Safety Officer to have a trained workstation evaluator assess the workstation. If you department does not have an evaluator, contact the Safety Officer.

**Completion Date:** \_\_\_\_\_.



## EMAX ORGANIZATION & MANAGEMENT

### B-5 Health & Safety Practices

## EMERGENCY EVACUATION ROUTE

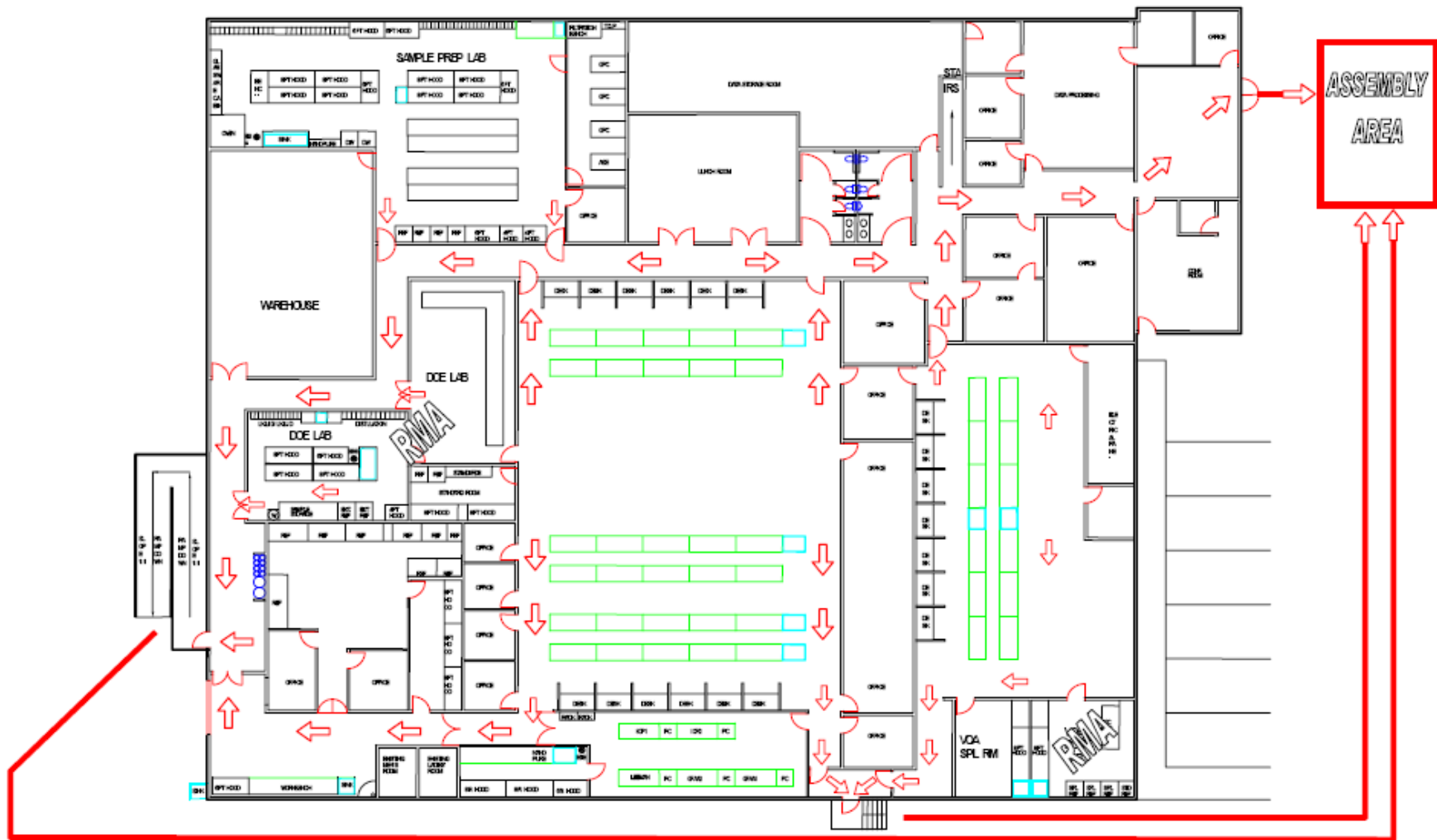

## EMAX ORGANIZATION & MANAGEMENT

### B-5 Health & Safety Practices

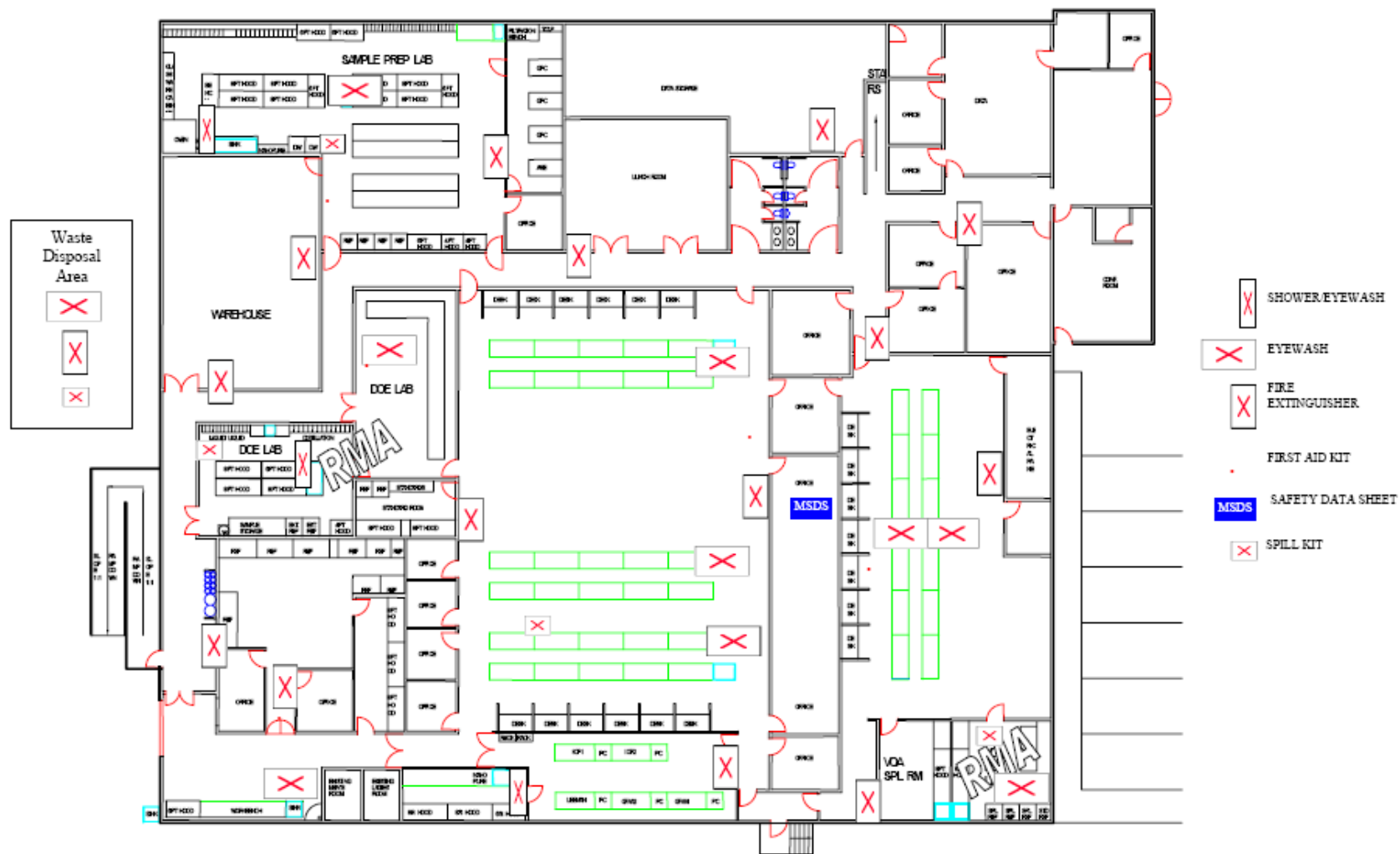

## LOCATION OF SAFETY MATERIAL AND EQUIPMENT



RMA – Radioactive Material Area

**EMAX ORGANIZATION & MANAGEMENT**  
**B-5 Health & Safety Practices**



|             |  |                   |
|-------------|--|-------------------|
| Approved By | <br>Richard Beauvil, Safety Officer | 8/26/19<br>Date   |
| Approved By | <br>Caspar Pang, President          | 5/26/2019<br>Date |

|               |              |
|---------------|--------------|
| Document ID   | EMAX-RTK-05  |
| Revision No.  | 5            |
| Date Released | 8/26/19      |
| Issue No.     | EMAX-RTK-05- |
| Issued To     |              |

## EMAX ORGANIZATION & MANAGEMENT

### B-5 Health & Safety Practices

---

#### RIGHT-TO-KNOW/HAZARD COMMUNICATION MANUAL

##### Table of Contents

|   | Pages |
|---|-------|
| 1.0 Right To Know Law/Hazard Communication Standard ..... | 2     |
| 2.0 Hazardous Substances Overview .....                   | 3     |
| 2.1 Introduction .....                                    | 3     |
| 2.2 Hazard Recognition .....                              | 3     |
| 2.3 Hazard Control .....                                  | 4     |
| 3.0 Safety Aspects of Hazardous Substances .....          | 5     |
| 4.0 Basic Precautions .....                               | 6     |
| 5.0 Emergency Procedures .....                            | 7     |
| 6.0 How To Read A Safety Data Sheet (SDS) .....           | 8     |
| 7.0 The Labeling System .....                             | 10    |
| 7.1 The Labeling System .....                             | 10    |
| 8.0 Corrosives/Irritants .....                            | 11    |
| 9.0 Gases .....   | 12    |
| 10.0 Mercury .....  | 13    |
| 11.0 Paints, Inks, and Dyes .....                         | 14    |
| 11.1 Hazards .....  | 14    |
| 11.2 Precautions/Control Measures .....                   | 15    |
| 12.0 Particles .....                                      | 16    |
| 13.0 Solvents/Oils .....                                  | 18    |
| 13.1 Health Effects .....                                 | 18    |
| 13.2 Precautions/Control Measures .....                   | 19    |
| 14.0 Heat .....   | 20    |
| 15.0 Noise .....  | 22    |
| 16.0 Glossary .....                                       | 23    |
| 17.0 Understanding a Safety Data Sheet .....              | 26    |

## EMAX ORGANIZATION & MANAGEMENT

### B-5 Health & Safety Practices

---

#### 1.0 RIGHT TO KNOW LAW/HAZARD COMMUNICATION STANDARD

The information and training presented in this program is designed to inform you about the potential work-related hazards in order to promote a safe and healthy work environment for all employees.

As a result of this training, each employee should know how to recognize and help control hazards present in the work environment. You should know what questions to ask, whom to ask, where to find important health and safety information, and how to apply the information to your own jobs, work areas, and work practices.

The following is a summary of the provisions contained in the Right to Know Law:

1. Annual training must be provided to all employees who are assigned to jobs in which they may be routinely exposed to hazardous substances (chemicals) and harmful physical agents (noise, heat).
2. Written information about hazardous substances and harmful physical agents must be made available.
3. All containers of hazardous substances, other than "immediate use" containers, must be labeled.
4. Records must be kept of all training sessions held.

Be sure and retain your training manual for future reference.

## EMAX ORGANIZATION & MANAGEMENT

### B-5 Health & Safety Practices

---

#### 2.0 HAZARDOUS SUBSTANCES OVERVIEW

##### 2.1 Introduction

Hazardous substances are present in every work environment and in every home. As you know, many substances are used every day without causing harm. But, exposure to too much of any substance or misuse of a substance may be harmful.

##### 2.2 Hazard Recognition

This is the first step in protecting yourself. Hazard is the probability that a substance will harm you. Hazard depends on how the substance is used, and how you come in contact with it. Toxic properties relate to the ability of a substance to produce injury or harm once it reaches the body.

Some substances are also safety hazards if they can easily catch fire, explode or react with other substances. Whenever they are in use or stored, there is a greater chance of an accident occurring.

The frequency and duration of exposure to chemicals also affects the hazard potential. You may work with a chemical every day for eight hours in your job. At home, you may use the same product very infrequently for only a short period of time.

It is important to remember that the amount of hazard presented by a substance is dependent upon:

1. the substance itself;
2. the amount that you are exposed to (concentration); and
3. how long you are exposed (time).

Remember: Hazard is not the same as toxicity. Toxic substances can be handled in a safe manner, if the proper precautions are taken and the substance is treated with a measure of respect.

The major ROUTES OF EXPOSURE of hazardous substances into the body are:

1. skin and eye contact/absorption;
2. inhalation (breathing); and
3. ingestion (swallowing)

**Note:** Exposures can occur through more than one route with the same chemical.

Exposure Limits: PELs (Permissible Exposure Limits - OSHA) and TLVs (Threshold Limit values - guidelines) are established. They are set at a level that is safe for the majority of persons working with the substance 8 hours a day, 40 hours a week, for a working lifetime.

## EMAX ORGANIZATION & MANAGEMENT

### B-5 Health & Safety Practices

---

#### 2.3 Hazard Control

When you use chemicals in your home or at work, you can protect yourself by taking some simple steps. Read the labels and pay attention to warnings and recommendations. If you use chemicals with sufficient information, common sense, and respect, you can protect yourself and others.

Controlling hazardous substances in the workplace is especially important, since the risks associated with using or producing chemicals are usually greater at work than at home. This increased risk is the result of exposure to a greater number and higher concentrations of chemicals, for a longer period of time in the workplace, as compared to the home.

Employers are responsible for providing a safe and healthy work environment. This includes providing effective methods to control potentially hazardous exposures. Employees are responsible for following the proper procedures of handling and using hazardous substances and harmful physical agents.

## EMAX ORGANIZATION & MANAGEMENT

### B-5 Health & Safety Practices

---

#### 3.0 SAFETY ASPECTS OF HAZARDOUS SUBSTANCES

Hazardous substances in the workplace can also be safety hazards, depending on certain properties that determine how likely they are to burn, explode, or react with other materials. It is important to understand these properties so that you can safely use, store, transport, and dispose of hazardous materials.

**FLAMMABLE MATERIALS** include any solid, liquid, vapor or gas that ignite at temperatures below 100°F, and burn quickly. (Xylene)

**COMBUSTIBLE MATERIALS** include any solid that is difficult to ignite and that it burns relatively slowly; or liquids that have a flashpoint above 100°F. (Mineral spirits)

**EXPLOSIONS** occur when flammable vapors or gases (such as hydrogen) or combustible dusts (such as grain) accumulate in a poorly ventilated area and are set on fire by a source of ignition.

**OXIDIZING AGENTS** give off oxygen at room temperature or upon slight heating. Contamination with dirt, other chemicals, moisture, etc. may start a chemical reaction generating heat and other gases. Some oxidizers may have a corrosive effect on body tissues. (Hydrogen peroxide)

**REACTIVE CHEMICALS** are substances that will easily react with other chemicals. The reaction can result in the production or absorption of heat, or a fire.

**STABLE CHEMICALS** have the ability to remain unchanged under expected and normal conditions of storage and use. Some materials such as explosives are **UNSTABLE**.

**INCOMPATIBLE MATERIALS** should never be mixed. Direct contact with one another could cause a dangerous reaction. (acids and bases)



## EMAX ORGANIZATION & MANAGEMENT

### B-5 Health & Safety Practices

---

#### 4.0 BASIC PRECAUTIONS

You can protect your health and safety on the job and at home; and you can prevent accidental exposures to hazardous materials by observing these basic precautions:

1. Always use common sense and safe work practices.
2. Know what chemicals you are handling and working with and the potential hazards.
3. Use personal protective equipment and clothing when appropriate.
4. Observe all safety procedures - they are for your protection.
5. Do not eat, smoke, or drink while you are working with hazardous materials.
6. Where applicable, know the location of the eye wash fountains and safety showers in your work area in case of an emergency.

## EMAX ORGANIZATION & MANAGEMENT

### B-5 Health & Safety Practices

---

#### 5.0 EMERGENCY PROCEDURES

In the event of an emergency involving contact with or overexposure to a hazardous substance:

#### **IMMEDIATELY NOTIFY YOUR SUPERVISOR AND SUMMON MEDICAL ASSISTANCE**

Be prepared to identify the chemical involved in the emergency.

**BASIC FIRST AID PROCEDURES** (while someone else is summoning medical assistance):

1. Chemical Contact - Eyes:  
**IMMEDIATELY** flush eyes with large amount of water for at least 15 minutes, while holding the eyes open for complete cleaning.
2. Chemical Contact - Skin:  
**IMMEDIATELY** wash the area with water for at least 15 minutes; do not scrub. Remove contaminated clothing.
3. Chemical Contact - Ingestion:  
If a person accidentally swallows a chemical agent, **IMMEDIATELY** seek emergency medical help and/or call the local poison information center (911) or a physician.
4. Chemical Contact - Inhalation:  
If a person is overcome by breathing airborne chemicals **IMMEDIATELY** move the person to fresh air. Restore breathing if necessary.

In ALL cases, seek medical attention and report the incident.

## EMAX ORGANIZATION & MANAGEMENT

### B-5 Health & Safety Practices

---

#### 6.0 HOW TO READ A SAFETY DATA SHEET (SDS)

The following is a short description of the information contained on a Safety Data Sheet (SDS), and how to read it and use this information. SDS's are accessed by the product trade name which can be found on the container label. To promote consistent presentation of information, OSHA recommends that SDS follow the 16-section established by the Globally Harmonized System (GHS).

**Section 1, Identification** includes product identifier; manufacturer or distributor name, address, phone number; emergency phone number; recommended use; restrictions on use.

**Section 2, Hazard(s) identification** includes all hazards regarding the chemical; required label elements.

**Section 3, Composition/information on ingredients** includes information on chemical ingredients; trade secret claims.

**Section 4, First-aid measures** includes important symptoms/ effects, acute, delayed; required treatment.

**Section 5, Fire-fighting measures** lists suitable extinguishing techniques, equipment; chemical hazards from fire.

**Section 6, Accidental release measures** lists emergency procedures; protective equipment; proper methods of containment and cleanup.

**Section 7, Handling and storage** lists precautions for safe handling and storage, including incompatibilities.

**Section 8, Exposure controls/personal protection** lists OSHA's Permissible Exposure Limits (PELs); Threshold Limit Values (TLVs); appropriate engineering controls; personal protective equipment (PPE).

**Section 9, Physical and chemical properties** lists the chemical's characteristics.

**Section 10, Stability and reactivity** lists chemical stability and possibility of hazardous reactions.

**Section 11, Toxicological information** includes routes of exposure; related symptoms, acute and chronic effects; numerical measures of toxicity.

**Section 12, Ecological information\***, Assists you in evaluating the effect a chemical may have if it's released to the environment.

**Section 13, Disposal considerations\***, Provides proper disposal information for environmental professionals or individuals responsible for waste management activities.

**Section 14, Transport information\***, Provides shipping classification information for the employer, distributor, emergency responders, and transport/shipping departments.

**Section 15, Regulatory information\***, Provides regulatory information for employers and regulatory compliance personnel.

## EMAX ORGANIZATION & MANAGEMENT

### B-5 Health & Safety Practices

---

Section 16, Other information, includes the date of preparation or last revision.

\*Note: Since other Agencies regulate this information, OSHA will not be enforcing Sections 12 through 15(29 CFR 1910.1200(g)(2)).

Employers must ensure that SDSs are readily accessible to employees.  
See Appendix D of 1910.1200 for a detailed description of SDS contents.  
For more information: [www.osha.gov](http://www.osha.gov)

## EMAX ORGANIZATION & MANAGEMENT

### B-5 Health & Safety Practices

---

#### 7.0 LABELING

Read all labels, on all containers

1. before you move them
2. before you open them
3. before you use the contents

Use of an unlabeled container is acceptable only when that container is intended for immediate use!

The label is your key to identifying the chemicals you work with.

#### 7.1 The Labeling System

##### A. Manufacturer's Labels



These labels are found on the original shipping containers. Read these labels carefully.

All containers of hazardous chemicals must be labeled with the following information:

The GHS standard requires that there be six label elements:

- Product identifier or ingredient disclosure; (Chemical Name, code number, or batch number)
- Signal Word; (Danger and Warning)
- Pictograms: (Very specific)
- Hazard statement; (Nature of the chemical and the degree of hazard)
- Precautionary statement; and (recommended measures to minimize or prevent adverse effect from exposure)
- Supplier identification. (Name, address, phone number)

Label Must be cross-referenced with the SDSs and the chemical inventory entry. Primary and Secondary containers must have the new label.

|   |  |   |
|---|--|---|
|  | <b>1</b> Sulfuric Acid   |  |
| <b>2</b>  | <b>3</b> Danger! May be harmful if swallowed. Causes severe skin burns and eye damage. Fatal if inhaled. Harmful to aquatic life.  |   |
|   | Do not breathe dust/fume/gas/mist/vapors/spray. Wear protective gloves/protective clothing/eye protection/face protection. Wear respiratory protection.                                |   |
| <b>5</b>  | IF IN EYES: Rinse cautiously with water for several minutes. Remove contact lenses, if present and easy to do. Continue rinsing. Immediately call a POISON CENTER or doctor/physician. |   |
|   | In case of fire Use water spray, alcohol-resistant foam, dry chemical or carbon dioxide.   |   |
|   | See Material Safety Data Sheet for further details regarding safe use of this product.   |   |
| <b>6</b>  | Sigma-Aldrich 3060 Spence Street SAINT LOUIS MO 63103 USA Telephone : +18003255832   |   |
| <b>1</b>  | Product Identifier   | <b>4</b> Hazard Statements  |
| <b>2</b>  | Pictograms   | <b>5</b> Precautionary Statements   |
| <b>3</b>  | Signal word, "Danger!"   | <b>6</b> Supplier Information   |

## EMAX ORGANIZATION & MANAGEMENT

### B-5 Health & Safety Practices

---

#### B. D.O.T. Labels.

These are picture labels with a word designation. This type of label gives you at-a-glance information about the properties of the material (for example, flammable or corrosive).

#### C. Waste Management's Labels

Labels will be placed on all containers (other than immediate use\*) that hazardous materials are transferred into. These labels will contain the product's trade name and a hazard warning. (A copy of the original shipping container label can be used.)

The **TRADE NAME** should be used to obtain further information about a particular chemical. Safety Data Sheets will be listed alphabetically by Trade Name.

#### D. Immediate Use labels

An "Immediate Use" container is a container into which substances are transferred from labeled containers and is used by the employee who performs the transfer.

## EMAX ORGANIZATION & MANAGEMENT

### B-5 Health & Safety Practices

---

#### 8.0 CORROSIVES/IRRITANTS

These chemicals can irritate, burn or destroy living tissue such as skin and mucous membranes. Contact with corrosives such as sodium hydroxide generally produce severe damage, such as burns. Irritants cause tissue inflammation as opposed to tissue destruction. Corrosives/irritants include acids and bases (alkalies, caustics) as well as other chemicals. The health effect depends on the chemical, the solution strength, and the length of time it is left in contact with the skin.

Exposure to irritants and corrosives usually occurs when they are spilled or splashed on the skin or in the eyes. When airborne, through heating or spraying, certain chemicals may be irritating to your nose and throat when inhaled. Some corrosives/irritants are in powder form.

Protective clothing that should be worn includes:

1. chemical-resistant gloves (length dependent on type of operation)
2. chemical goggles or faceshield, during pouring or mixing if there is a chance of splashing
3. apron or other garment dependent on the extent of exposure (splash 3. potential)
4. chemical-resistant shoes, as necessary.

**CORROSIVE/IRRITANT CHEMICALS** include: General Purpose Cleaner (1 57), PW901, Power Wash, sodium hydroxide (caustic soda), ammonia, soda ash, sulfuric acid (battery acid), boiler compounds, water treatment chemicals, cleaning chemicals, bleach, muriatic acid (hydrochloric acid), nitric acid, acetic acid, and disinfectants and germicides

Remember: When mixing acid or bases and water, always add the acid or base to water. Never directly mix acids and bases, since a violent reaction can occur upon mixing.

Refer to the Safety Data Sheet and the product label for important health and safety information on each specific substance.

## EMAX ORGANIZATION & MANAGEMENT

### B-5 Health & Safety Practices

---

#### 9.0 GASES

A material is called a gas if its typical physical state at normal temperature and pressure. Substances that are normally a solid or liquid at room temperature can change their physical state to a gas, upon heating, burning or decreasing pressure.

Most gases are colorless at low concentrations and cannot be seen. Some gases (i.e. ammonia and chlorine) can be detected by their odor and irritating effects at certain concentrations. Gases such as carbon monoxide, have no odor or immediately irritating effect on the body. In general, gases can be inhaled directly into the lungs, where they are either absorbed into the blood or exhaled. Some gases will immediately irritate the respiratory system.

Gases are used directly in some work processes, or they can occur as by-products from work processes or operations, such as carbon monoxide from fuel-operated fork lift trucks. Gases may also be contained in pressurized cylinders such as compressed gases (acetylene, oxygen and propane).

**ASPHYXIANTS:** These gases interfere with the body's ability to utilize oxygen. Simple asphyxiants are gases that in a normal atmosphere are safe, but in confined or poorly ventilated spaces can accumulate. This displaces the normal amount of oxygen we depend upon to sustain life. Methane, argon, helium, and nitrogen are examples of simple asphyxiants. Chemical asphyxiants, interfere with the transportation and use of oxygen by the tissues in the body. Overexposure to chemical asphyxiants such as carbon monoxide and hydrogen cyanide can also result in suffocation. Initial symptoms include: headache, dizziness, and nausea. Symptoms will usually subside upon ceasing exposure to the asphyxiant gas.

**COMPRESSED GASES:** Containers of compressed gas should be handled very carefully. Cylinders should be stored and secured in an upright position in a well-protected and ventilated area. Cylinders should always be capped during use and transport. Oxygen and chlorine cylinders should be stored separately from fuel gas cylinders. If a leak occurs due to a faulty valve or piping, stop the gas flow, if it can be done safely. If not, evacuate the area, and get assistance. Other commonly used compressed gases include propane (flammable), nitrogen, ammonia, argon and acetylene.

**VEHICLE EXHAUST EMISSIONS:** Vehicle exhaust emissions consist of carbon monoxide and other gases, particulate (including lead) and aldehydes. Carbon monoxide is produced in higher concentrations from the combustion of gasoline, as compared to diesel fuel. Diesel fuel tends to produce more of the irritating particulate and gases.

The most common irritants that can be found in vehicle exhaust emissions include oxides of nitrogen and aldehydes. In high concentrations, they may irritate the nose and respiratory tract.



## EMAX ORGANIZATION & MANAGEMENT

### B-5 Health & Safety Practices

---

#### 10.0 MERCURY

Mercury, a heavy metal, has the unique property of being a liquid at room temperature. Mercury is highly toxic and exposure should be kept to a minimum. Emotional and psychic disturbances, as well as digestive disorders and liver damage are characteristic of chronic mercury poisoning. Symptoms include: headache, dizziness, Irritability, tremors of the hand, head, lips, or jaw, salivation, inflammation of the gums, nausea, vomiting and diarrhea.

Inhalation is the main route of exposure, but mercury can also be absorbed through skin contact or ingestion.

1. Good housekeeping is essential. All spills must be cleaned up immediately and thoroughly. Employees must be trained on proper spill clean-up procedures. To prevent mercury build-up in cracks and crevices due to spills, laboratory work surfaces should be smooth.
2. Mercury, including waste material, must be properly stored in airtight, nonmetallic containers.
3. Adequate laboratory ventilation will minimize exposure to mercury vapors.
4. Proper work procedures, use of personal protective equipment as needed, and good personal hygiene is very important when working with mercury.

## EMAX ORGANIZATION & MANAGEMENT

### B-5 Health & Safety Practices

---

#### 11.0 PAINTS, INKS AND DYES

HAZARD POTENTIAL is dependent upon the following:

- Method of Application:  
hand  
mechanical dipping  
spraying
- Type of Paint, Ink or Dye:  
oil base  
water base  
polyurethane  
epoxy
- Control Measures Present  
local exhaust  
personal protective equipment  
spray booths
- Type of pigment or base in the paint, ink or dye.  
lead chromate  
titanium dioxide  
Cadmium  
aniline
- Type of Solvents  
used in the paint, ink or dye  
used in the department  
Examples: xylene, toluene, and naptha

#### 11.1 Hazards

1. Dermatitis - Dermatitis may occur from either excessive skin contact with solvents or occasionally from the paint, ink or dye itself.
2. Solvent Vapor Inhalation - General symptoms include dizziness, headache, nausea, and eye and nose irritation. See the section on solvents for further information.
3. Inhalation of Paint and Ink Pigments - Some paints and inks contain toxic heavy metals such as lead, zinc chromates and cadmium. Long term health effects from overexposure may include lung damage from chromate and cadmium compounds. And possibly damage to the bloodforming, nervous and reproductive systems from lead.
4. Sensitization - Urethane and epoxy paints cause respiratory and skin sensitization; and allergic reaction. The allergy develops over a period of time of exposure to the vapors or the liquid.
5. Aniline compounds can be absorbed through the skin and overexposure

## EMAX ORGANIZATION & MANAGEMENT

### B-5 Health & Safety Practices

---

may result in cyanosis. Chronic overexposure may result in liver or kidney damage.

#### 11.2 Precautions/Control Measures

1. Wear protective clothing (i.e., gloves, barrier cream or coveralls) as required or as needed to prevent prolonged skin contact with paints. Avoid skin contact with aniline-based dyes.
2. Wear a respirator as needed. Make sure the appropriate cartridges are used; organic vapor cartridges to reduce exposure to the solvent vapors. May also be used in combination with a paint pre-filter.
3. Do not remove paint from your skin using solvents. Use a waterless skin cleaner or soap and water.
4. Good personal hygiene is very important.

## EMAX ORGANIZATION & MANAGEMENT

### B-5 Health & Safety Practices

---

#### 12.0 PARTICLES

Some chemicals are present as particles in the air or on surfaces. Particle types include: dust, fume, smoke, mist, and fog.

Dusts, fumes and smoke consists of solid particles. Dusts are produced by sanding, grinding, crushing, and handling powdered materials, etc. Fumes are produced when metals are melted during welding and foundry operations. Smoke usually is the result of heating or burning a material.

Mists and fogs consists of liquid particles. Mists are liquid droplets that are produced by breaking up a liquid such as in spraying. Fogs are formed when humid air cools and the water vapor condenses.

Particles are easily released into the air and can settle onto exposed work surfaces. If the particles remain in the air, you can inhale them. Depending on their size, they may get trapped in your nose, or if they are small enough, they can reach your lungs.

If solid particles settle out of the air, like dust in your home, they can contaminate the floor and work surfaces. If the particles are not cleaned up, they can be made airborne again. If you touch surfaces that are contaminated with toxic dusts, you could transfer the particles from your hands or clothing to your mouth.

Exposure to particles can result in a variety of symptoms ranging from irritation to lung damage; again depending on the concentration, length of exposure and the toxicity of the material.

**ASBESTOS:** Inhalation of excess asbestos fibers can result in asbestosis. Symptoms of asbestosis include chest pain, breathing difficulty, dry sound during Breathing, and weight loss. Lung cancer and mesothelioma (cancer of the chest lining) may also result from excessive asbestos inhalation. Smoking enhances the lung cancer causing properties of asbestos. Special procedures must be followed when working with asbestos to prevent inhalation of the fibers.

**BRAZING AND SOLDERING:** When brazing or soldering, the exposure depends on the base metal, the filler metal composition, the temperature and the type of flux. Thermal decomposition products from fluxes may be irritating to the eyes, nose and throat. There is also a potential for exposure to lead, silver and cadmium and other metal fumes. These fumes have the potential to cause respiratory irritation, as well as long term health effects such as lung damage or neurological disorders, with chronic overexposure. Some fluxes are also skin irritants. \*Metal Fume Fever - Overexposure to metal fumes (commonly zinc or copper) may produce this effect. The symptoms are similar to the flu and usually occur a few hours after the exposure.

**LEAD:** Sources of lead include paint pigment, automobile exhaust, gasoline additives, and welding and soldering. Lead poisoning may occur through inhalation or accidental ingestion. The symptoms of chronic overexposure include: loss of appetite, anemia, and muscle and joint pain. The liver, kidneys, and reproductive systems may also be affected.

**METAL DUST AND FUMES:** Iron oxide is the major metal fume generated from

## EMAX ORGANIZATION & MANAGEMENT

### B-5 Health & Safety Practices

---

heating mild steel. Iron/Iron oxide and Aluminum/Aluminum oxide, as well as other metal dusts, may cause respiratory irritation. Metal work on parts containing toxic metals such as Nickel, Chromium, Copper, Cadmium or Beryllium increase the health hazard potential. Follow the safety procedures established for welding or soldering. Read and follow all warning labels. Use all required protective equipment. (See section on welding, if applicable).

**NUISANCE DUST:** This includes plastic, dirt, 'house dust', etc. At high concentrations, dusts may cause respiratory irritation in some individuals. In general, nuisance dusts are so named because they do not have a toxic effect on the body.

**WOOD DUST:** At high concentrations, wood dust can act as a respiratory and eye irritant. Certain woods, including pine, beech and mahogany can cause an allergic response (asthma and dermatitis) in sensitized individuals. Chronic overexposure to certain hardwood dusts is suspected of causing nasal cancer.

## EMAX ORGANIZATION & MANAGEMENT

### B-5 Health & Safety Practices

---

#### 13.0 SOLVENTS/OILS

**SOLVENTS** are a class of liquids that are used to dissolve certain other solid materials (clean, degrease, thin). They will be found in paints, inks, dyes, thinners, cleaners, resins and adhesives. Petroleum based oils are also included in this section due to their similar characteristics. Solvents and oils used at EMAX Laboratories, Inc. include some of the following:

- a. Acetates (cellosolve acetate, butyl acetate, ethyl acetate)
- b. Alcohols (isopropyl alcohol, butyl alcohol, ethyl alcohol)
- c. Aldehydes (formaldehyde, acetaldehyde)
- d. Aliphatic hydrocarbons (hexane, nitropropane)
- e. Aromatic hydrocarbons (styrene, xylene, phenol, toluene)
- f. Chlorinated hydrocarbons (trichloroethane, trichloroethylene, methylene chloride, perchloroethylene, chloroform, carbon tetrachloride)
- g. Esters (butyl cellosolve, methyl cellosolve, ethoxy ethanol)
- h. Ethers (diethyl ether)
- i. Fluorinated hydrocarbons (freons, trichlorotrifluoromethane)
- j. Ketones (methyl ethyl ketone, methyl isobutyl ketone, acetone)
- k. Mixtures (stoddard solvent, petroleum distillates, naphtha, mineral spirits, kerosene, turpentine, gasoline, laquer thinner, oils)

Properties of Solvents:

- a. Many solvents are flammable.
- b. In general, solvents evaporate quickly.
- c. With heating, evaporation rate is quicker.
- d. Upon exposure to flames, chlorinated hydrocarbons can decompose generating hydrogen chloride and phosgene.

#### 13.1 Health Effects

1. **SKIN DISORDERS.** Repeated skin contact can cause a rash or irritation (dermatitis), as well as dry out the skin to the point of cracking and bleeding. Solvents should not be used to wash or clean the skin. Some solvents can be absorbed both through contact, as well as open skin. Particular attention should be paid to contact with these materials. This information will be noted on the Safety Data Sheet. Oils tend to block skin pores upon prolonged exposure and may cause inflammation (folliculitis).
2. **EYE INJURY:** Solvent vapors can irritate the eyes. Directly splashing the liquid into eyes may cause serious burns, and possible permanent damage.
3. **INHALATION:** Solvents act as central nervous system depressants. General symptoms include: headache, dizziness, nausea. Generally, when the exposure is stopped, the reactions will disappear. Extreme overexposure situations could lead to unconsciousness. Solvent vapors can also act as respiratory irritants. Chronic overexposure to some solvents, such as trichloroethylene and carbon tetrachloride, may cause permanent injury to the liver or kidneys, or other internal systems.

## EMAX ORGANIZATION & MANAGEMENT

### B-5 Health & Safety Practices

---

Certain 'cellosolve' products such as cellosolve acetate, cellosolve (ethoxy ethanol), and methyl cellosolve (methoxy ethanol) may cause reproductive disorders with chronic overexposure. Chloroform, carbon tetrachloride and formaldehyde are suspect carcinogens.

Inhalation of oil would occur as oil mist from splashing or as vapors/mist (similar to the above) upon heating. Oil mist/vapors can be irritating.

#### 13.2 Precautions/Control Measures

1. Wear solvent resistant gloves to prevent repeated or prolonged skin contact.
2. In operations where the liquid could splash into the eyes, chemical goggles or a face shield should be worn. In case of eye contact, flush the eyes with water for at least 15 minutes, while holding the eyelids open.
3. In operations where the liquid could splash onto the skin, appropriate protective clothing, such as a solvent-resistant apron, should be worn.
4. If extensive skin contact should occur, flush the area thoroughly for at least 15 minutes.
5. Personal hygiene is very important, Wash thoroughly. Apply hand cream as needed to prevent drying. Do not wash up with solvents, use soap and water or a waterless skin cleaner.
6. In situations where a respirator is required, be sure the proper respirator is worn. It should protect you against organic vapors for solvents, and dusts/mists for oil mist.
7. In Case of a solvent spill or leak, avoid contact with the material, wear an organic vapor respirator to prevent overexposure during cleanup operations. Attempt to stop the spread of the material. Remove all ignition sources.



## EMAX ORGANIZATION & MANAGEMENT

### B-5 Health & Safety Practices

---

#### 14.0 HEAT

Heat is another physical agent to which you can be exposed. Your body internally produces heat as a result of metabolic activity. When the body is exposed to excessive external heat, the natural response is sweating: the body's method for cooling down.

The amount of sweat loss depends on the environmental conditions, the length of exposure, and the degree of activity.

The effects of overexposure to heat (heat stress) can range from a mild reaction, such as heat exhaustion, to a very serious reaction such as heat stroke. Heat stroke is a serious medical condition that must be treated immediately and correctly, or it can result in death or permanent damage. Emergency medical assistance should be called for immediately.

##### Preventing Heat Stress at Work and at Home:

1. Gradual exposure over a period of time allows the body to get used to higher environmental temperatures. This process is called acclimatization.
2. During periods of extreme heat and humidity, adjusting the work-rest cycle may be necessary. For example, increasing the frequency of rest breaks.
3. Fans are helpful in indoor situations, except in extreme heat.
4. Drink plenty of fluids throughout the day, not just during breaks. Do not depend on thirst to signal that the body needs fluids.
5. Replace salt lost by heavy sweating by: (a) lightly salting food at meals; (b) eating a salty snack; or (c) drinking electrolyte replacement fluids (such as Gatorade) in small quantities.
6. Avoid the use of salt tablets. Too much salt without adequate water may cause nausea and vomiting.
7. The most strenuous tasks should be performed during cooler parts of the day, when possible.

##### Health Problems Associated with Excessive Heat

1. Heat Cramps are painful muscle spasms that occur when an individual sweats profusely, drinks large quantities of water, but fails to replace the body salts lost during the sweating process. The low salt concentration in the muscle results in cramps. Muscles used in performing work (in particular the arms, legs, and abdomen) are usually the most susceptible.

**Treatment:** Move victim to a cool area. Apply manual pressure to the spasm. Give salt water or other sodium replacement fluid. Caution: Persons with heart problems or those on a low sodium diet must consult a physician regarding what to do under these conditions.

2. Heat Exhaustion is caused by dehydration due to excessive sweating. It results in general weakness, dizziness, nausea, and possibly fainting. The victim continues



## EMAX ORGANIZATION & MANAGEMENT

### B-5 Health & Safety Practices

---

sweating. The skin is clammy and moist; the complexion is pale or flushed; and the body temperature remains normal. Persons who are unacclimatized, physically unfit, or obese are more prone to experience heat exhaustion.

**Treatment:** Seek medical assistance. Move victim to a cool area. Lower the head. Loosen any restrictive clothing. Give water if victim is conscious.

3. Heatstroke is the most serious health problem from exposure to excessive heat. Sweating stops, leaving the body with no means to get rid of excess heat. A heatstroke victim's skin is hot, dry, and usually red or spotted. The body temperature rises to dangerous levels of 105 degrees or higher. The person is mentally confused, irritable and may complain of feeling chilled. Heatstroke can result in convulsions, coma, and possibly death.

**Treatment:** Seek medical assistance. Move victim to a cool area. Elevate the legs. If the victim is unconscious, maintain an open airway. Remove as much clothing as possible. Soak the person with cold water. Use a fan or other method to assist in cooling down the body. Do not give anything by mouth. Prompt and Proper treatment is essential!

## EMAX ORGANIZATION & MANAGEMENT

### B-5 Health & Safety Practices

---

#### 15.0 NOISE

Noise is defined as unwanted sound. Exposure to loud noise can result in different types of hearing loss. Temporary hearing loss can result from exposure to loud noise for a short period of time. Your ears usually recover from this type of loss if given adequate time. With chronic exposure to excessive noise levels, your ears may lose their ability to recover from the hearing loss, and it gradually becomes permanent.

Safe exposure levels to noise have been established for the workplace by OSHA. Continuous exposure below 85 dBA, day after day, should not result in permanent hearing loss for the majority of people.

The OSHA Hearing Conservation Amendment requires that a hearing conservation program be initiated if the exposure levels exceed 90 dBA over 8 hours, the OSHA Noise Standard requires that engineering or administrative controls be utilized where and when feasible.

If you work in an area where the noise levels exceed those permitted by OSHA, you will be provided with hearing protection and periodic hearing tests. Signs must be posted in areas where the noise levels (employee exposure) exceed the OSHA limits, warning employees of the potential hazards, and informing them that hearing protection is required.

## EMAX ORGANIZATION & MANAGEMENT

### B-5 Health & Safety Practices

---

#### 16.0 GLOSSARY

|                              |  |
|------------------------------|--|
| <b>Action Level</b>          | The level of exposure for a hazardous substance or agent at which certain provisions of the standards or guidelines must be initiated.   |
| <b>Acute</b>                 | A toxic effect or reaction that occurs over a short period of time.  |
| <b>Breathing Zone Sample</b> | An air sample collected in the breathing area of a worker to measure his/her exposure to airborne contaminants.  |
| <b>Carcinogen</b>            | Any substance that is capable of causing the development of cancer in living tissue. Example: asbestos   |
| <b>Chronic</b>               | Describes continued and repeated exposure, generally over a long period of time, to hazardous materials or harmful physical agents and the health effects that result from this type of exposure.                            |
| <b>Combustible</b>           | Any solid that is difficult to ignite and that burns relatively slow; or liquids that have a flashpoint above 100°F. Example: wood   |
| <b>Corrosive</b>             | Any solid, liquid, or gas that burns, irritates, or destroys body tissues, usually the skin. When swallowed, the lungs and stomach will be affected. Example: strong acids (nitric acid) and strong bases (sodium hydroxide) |
| <b>Dermatitis</b>            | Inflammation of the skin.  |
| <b>Dose</b>                  | A term used to express the amount of hazardous substance or harmful physical agent absorbed by a body organ or an individual. (Concentration and duration).  |
| <b>Flammable</b>             | Any solid, liquid, vapor, or gas that ignites easily and burns rapidly; liquids that have a flashpoint below 100°F.  |
| <b>Gas</b>                   | A material that is a gas under normal pressure and room temperature. Example: chlorine   |
| <b>Latent Period</b>         | The time which elapses between exposure to a chemical or physical agent and the appearance of symptoms.  |

## EMAX ORGANIZATION & MANAGEMENT

### B-5 Health & Safety Practices

---

|                                 |   |
|---------------------------------|---|
| <b>Safety Data Sheets</b>       | Any data sheet which contains information pertaining to the physical, chemical, and hazardous properties of a substance or mixture.   |
| <b>Mg/M<sup>3</sup></b>         | Milligram (mg) of substance per cubic meter (m) of air. Unit of measurement of dusts and other particles.   |
| <b>Mutagen</b>                  | A substance capable of causing abnormal changes in living cells. All carcinogens are mutagens, but not all mutagens are carcinogens. Example: ionizing radiation.   |
| <b>NIOSH</b>                    | National Institute for Occupational Safety and Health (research)  |
| <b>OSHA</b>                     | Occupational Safety and Health Administration (research)  |
| <b>PEL</b>                      | Permissible Exposure Limit. Legally enforceable limit set by OSHA.. Safe exposure level. (See page 3 of this manual)  |
| <b>PPM</b>                      | Parts per million (ppm) of the substance per million parts of air. Unit of measurement for gases and vapors.  |
| <b>Reproductive Toxic Agent</b> | Substances which interfere with the normal production of sperm or ovum or produce abnormalities in the embryo or fetus.   |
| <b>Respirator</b>               | A device worn over the nose and mouth to filter out hazardous substances from an individual's breathing air.  |
| <b>Sensitizer</b>               | Hazardous materials that have the ability to produce an allergic reaction in exposed workers.   |
| <b>Susceptibility</b>           | The varied responses of different persons to the same hazardous material. The usual factors affecting the response include age, sex, and general health.  |
| <b>Synergistic</b>              | Occurs when the combined effect of hazardous materials acting together on the body is greater than the sum of the effect of each agent acting alone. Example: asbestos and cigarette smoking produce a synergistic effect on the lungs. |
| <b>Teratogen</b>                | A substance capable of producing a severe abnormality in an embryo or fetus. Examples: methylmercury, thalidomide.  |

## EMAX ORGANIZATION & MANAGEMENT

### B-5 Health & Safety Practices

---

|          |   |
|----------|---|
| Toxicity | The ability of a hazardous substance to produce a harmful effect on a living organism.              |
| TLV      | Threshold Limit Value. Guideline exposure limits. (See page 3 in this manual)                       |
| Vapor    | Vapors are formed by the evaporation of a substance which is normally a liquid at room temperature. |

## EMAX ORGANIZATION & MANAGEMENT

### B-5 Health & Safety Practices

---

#### 17.0 UNDERSTANDING A SAFETY DATA SHEET

The following is a description of the information contained in a Safety Data Sheet (SDS); and how to read it and use this information. SDS can be accessed by the product Trade Name which can be found on the container label.

Section 1 gives details of the company issuing the data sheet....

**SECTION I: Identification:**

Trade name: Benzene

Manufacturer/Supplier:

Alfa Aesar, A Johnson Matthey Company Johnson Matthey Catalog Company, Inc. 30 Bond Street Ward Hill, .....

.... and, often, emergency call-out information. Emergency information: During normal hours the Health, Safety and Environmental Department. After normal hours call .....

---

The second section summarizes the major hazards associated with use of the chemical. The R and S codes in this section are followed by explanatory text.

**SECTION II: Hazards identification**

Hazard description:

T Toxic F Highly flammable

Information pertaining to particular dangers for man and environment

R 45 Can cause cancer - Group I (extremely hazardous)

R 11 Highly flammable.

R 48/23/24/25 Toxic: danger of serious damage to health by prolonged exposure through inhalation, in contact with skin and if swallowed.

---

The third section identifies the material, and gives the CAS and other registry numbers.

**SECTION III: Composition, Information on Ingredients:**

Benzene (CAS# 71-43-3); 100%

Identification number(s):

EINECS Number: 200-753-7

EU Number: 601-020-00-8

---

The fourth section outlines first aid measures.

**SECTION IV: First aid measures**

After inhalation: Supply fresh air. If required, provide artificial respiration. Keep patient warm.

Seek immediate medical advice. After skin contact .....

---

Section 5 covers fire fighting and protective equipment.

**SECTION V: Fire fighting measures**

Suitable extinguishing agents Carbon dioxide, extinguishing powder or water spray. Fight larger fires .....

---

Section 6 outlines the procedures to be followed in case of accidental release of the chemical, including methods to be used to clean up spills. Note that these measures are

## EMAX ORGANIZATION & MANAGEMENT

### B-5 Health & Safety Practices

---

unlikely to be sufficiently detailed if the chemical is particularly hazardous, and local procedures should be drawn up to supplement what is given in the SDS sheet.

#### **SECTION VI: Accidental release measures**

Person-related safety precautions: Wear protective equipment.....

Measures for environmental protection..... Do not allow material to be released to the environment without proper governmental permits. Measures for cleaning/collecting: Absorb with liquid-binding material (sand, diatomite, acid binders, universal binders, sawdust).

Dispose contaminated material as waste according to item 13 .....

---

Section 7 is self-explanatory. This is an important section, sometimes overlooked by those using chemicals in the laboratory. It contains information about the possible formation of peroxides in storage, flammability, explosive risks, etc. Pay particular attention to the possible need for flammable storage cabinets, explosion-proof fridges, and also the need to avoid storage near incompatible chemicals.

#### **SECTION VII: Handling and storage**

Information for safe handling:

Keep container tightly sealed. Store in cool, dry place in tightly closed containers. Ensure good ventilation at the workplace. Information about protection against explosions and fires: Keep ignition sources away. Protect against electrostatic charges. Fumes can combine with air to form an explosive mixture.

Storage

Requirements to be met by storerooms and receptacles: Store in a cool location. Store away from oxidizing agents .....

---

Section 8 provides information on regulatory standards for exposure, in other words, the maximum permitted concentration of the material in the environment to which you are allowed to be exposed. It also usually contains information on suitable types of PPE (personal protective equipment)

#### **SECTION VIII: Exposure controls and personal protection**

Additional information about design of technical systems: Properly operating chemical fume hood designed for hazardous chemicals and having an average face velocity of at least 100 feet per minute. Components with limit values that require monitoring at the workplace:

Benzene mg/m<sup>3</sup> ml/m<sup>3</sup> ACGIH TLV short term 1.6 0.5 ACGIH TLV long term 8 2.5 B VME 1,6 0,5 .....

Personal protective equipment General protective and hygienic measures The usual precautionary measures for handling chemicals should be followed. Keep away from foodstuffs, beverages and feed. Remove all soiled and contaminated clothing immediately..... Wash hands before breaks and at the end of work. Breathing equipment:.....

Protection of hands: Impervious gloves

Eye protection: Safety glasses, Full face protection .....

---

Section 9 is self-explanatory

#### **SECTION IX: Physical and chemical properties:**

Form: Liquid

Color: Colorless

Odor: Aromatic



## EMAX ORGANIZATION & MANAGEMENT

### B-5 Health & Safety Practices

---

Change in condition  
Melting point/Melting range: 5.51 °C  
Boiling point/Boiling range: 80.1 °C  
.....

---

The next section is also largely self-explanatory.

#### **SECTION X: Stability and reactivity**

Thermal decomposition / conditions to be avoided: Decomposition will not occur if used and stored according to specifications.

Materials to be avoided: Oxidizing agents

Dangerous reactions No dangerous reactions known

Dangerous products of decomposition: Carbon monoxide and carbon dioxide

---

Section 11 outlines the risks to which you may be exposed when using the chemical. It is therefore a section of crucial importance!

#### **SECTION XI: Toxicological information**

Acute toxicity: (The acute toxicity gives an indication of the kind of quantities of the chemical which may cause immediate damage to health if swallowed, inhaled or absorbed through the skin.)

LD/Lc50 values that are relevant for classification: If you have never heard of LD50s, look in the [glossary on this site](#).

Oral: LD50: 3306 mg/kg (rat)

Dermal: LD50: 48 mg/kg (mus)

Inhalative: LC50/7H: 10.000 ppm/7H (rat)

(There follows a section which gives, often in some detail, an indication of the health effects which may be attributable to this chemical. This section should be read particularly carefully, since the range of health effects may be broad, and may include carcinogenic or sensitizer effects.)

Primary irritant effect:

on the skin: Irritant to skin and mucous membranes.

on the eye: Irritating effect.

Sensitization: No sensitizing effects known. (Chemical sensitisation, for example by platinum compounds, is a potentially debilitating problem. Pay particular attention to any information which may suggest that the chemical is a sensitiser.)

Subacute to chronic toxicity: (Here we find details of the possible long-term effects of exposure to the chemical.)

Benzene has a strong irritating effect, producing erythema and burning. Edema and blistering is possible in more severe cases. Absorption through the skin may cause the same symptoms as inhalation or ingestion. These include gastrointestinal irritation, low blood pressure, headache, blurred vision, nausea, vomiting, dizziness, loss of balance and coordination, confusion, unconsciousness, coma, respiratory failure and death. Blood, liver and kidney damage is possible. Benzene is a recognized leukemogen and an experimental mutagen and teratogen.



## EMAX ORGANIZATION & MANAGEMENT

### B-5 Health & Safety Practices

---

**Additional toxicological information:**

To the best of our knowledge the acute and chronic toxicity of this substance is not fully known. (For this chemical there now follow important comments regarding the carcinogenicity. The acronyms such as IARC refer to regulatory or health agencies.)

EPA-A: human carcinogen: sufficient evidence from epidemiologic studies to support a causal association between exposure and cancer.

IARC-2A: Probably carcinogenic to humans: limited human evidence; sufficient evidence in experimental animals

NTP-2: Reasonably anticipated to be a carcinogen: limited evidence from studies in humans or sufficient evidence from studies in experimental animals.

ACGIH A2: Suspected human carcinogen: Agent is carcinogenic in experimental animals at dose levels, by route(s) of administration, at site(s), of histologic type(s), or by mechanism(s) considered relevant to worker exposure. Available epidemiologic studies are conflicting or insufficient to confirm an increased risk of cancer in exposed humans.

---

Section 12 is largely self-explanatory

**SECTION XII: Ecological information:**

General notes: Do not allow material to be released to the environment without proper governmental permits.

---

Section 13, which deals with disposal, is often not sufficiently detailed for you to be able to undertake disposal yourself. If you need to dispose of the chemical after use, ensure that you know how to do this safely.

**SECTION XIII: Disposal considerations**

Consult state, local or national regulations for proper disposal.

---

Section 14 gives transport information, generally as a list of codes indicating the dangers associated with the chemical (flammable, radioactive, very toxic, etc) and the type of transport which may be used. There are usually UN hazard codes given in this section. A guide to these is available [here](#).

**SECTION XIV: Transport information**

DOT regulations:

Hazard class: 3 Identification number: UN1114 Packing group: II .....

---

Section 15 lists the hazard codes (see [glossary](#) if you are not familiar with these) which indicate the principle hazards associated with the chemical and the precautions which should be taken when working with it.

**SECTION XV: Regulations**

Hazard symbols:

T Toxic F Highly flammable

Risk phrases:

45 Can cause cancer - Group I (extremely hazardous)

11 Highly flammable.

48/23/24/25 Toxic: danger of serious damage to health by prolonged exposure through

## EMAX ORGANIZATION & MANAGEMENT

### B-5 Health & Safety Practices

---

inhalation, in contact with skin and if swallowed.  
A full list of these risk phrases is given [here](#).

Safety phrases:

20 When using do not eat or drink.

28 After contact with skin, wash immediately with plenty of ...

36/37/39 Wear suitable protective clothing, gloves and eye/face protection.

45 In case of accident or if you feel unwell, seek medical advice immediately.

A full list of safety phrases is available [here](#).

National regulations (This may include a variety of country-specific detail) All components of this product are listed in the U.S. Environmental Protection Agency Toxic Substances Control Act Chemical Substance Inventory .....

This product contains a chemical known to the state of California to cause cancer or reproductive toxicity.

This product contains benzene and is subject to the reporting requirements of section 313 of the Emergency Planning and Community Right to Know Act of 1986 and 40CFR372.

---

Finally, a section of an additional information, such as the name of the person preparing the data sheet, a list of references from which data have been drawn, disclaimers, etc.

#### **SECTION XVI: Other information:**

Employers should use this information only as a supplement to other information gathered by them, and should make independent judgement of suitability of this information to ensure proper use and protect the health and safety of employees .....

Contact:

## QUALITY SYSTEMS FOR CHEMICAL TESTING

---

### c) Surrogates

Recovery of surrogates on a given sample is a gauge of accuracy of target analytes detected on a given sample. Recoveries shall be evaluated against project surrogate control limits otherwise, in-house limits shall be used. When recovery exceeded surrogate control limits, project prescribed corrective action shall be applied. When re-analysis is necessary, it shall be performed unless prohibiting factors are present (e.g., re-analysis will cause damage to instrument or chromatography obviously display qualitative and quantitative quandary).

### 1.7.5. Sample Handling

#### a) Thermal Preservation

Samples are generally received on coolers cooled by ice unless thermal preservation is not required. Temperature is checked and documented in accordance to EMAX-SM02 SOP for Sample Receiving.

#### b) Chemical Preservation

Samples that are chemically preserved are also checked and documented during sample receipt with the exception of the samples that are not amenable to be opened or sub-sampled prior to analysis (e.g., samples for volatile analyses, oil and grease). Details for this procedure are also described in EMAX-SM02.

#### c) Holding Time

Sample holding time is checked against the COC sampling date and time. Maximum holding time for analyses are listed in EMAX-SM02.

For a test with recommended maximum holding time measured in hours, the holding time is tracked by the hour. For a test with recommended maximum holding time measured in days, the holding time is tracked by the day. For a test with a recommended maximum holding time measured in months, the holding time shall be tracked by the month. One month is defined as 30 days.

#### c) Start Time Determination

For extraction, the moment that extraction solvent touches the sub-sample determines the start time. For analysis, the moment that the extract (or sample) is introduced into the analytical instrument determines the start time.

---

Appendix D  
Laboratory Standard Operating  
Procedures





**LABORATORIES, INC.**  
1835 W. 205th Street  
Torrance, CA 90501  
Tel: (310) 618-8889

Page 1 of 1

ADDENDUM TO

|                  |                            |
|------------------|----------------------------|
| Document         | ALL ANALYTICAL SOPS        |
| Revision Number  | CURRENT REVISIONS          |
| Section          | 10.2 Instrument Parameters |
| Date             | 11 September 2019          |
| Reference Number | AA.7                       |

This applies to all GC/MS, GC, HPLC-MS, HPLC, ICP-MS, ICP and IC Method SOPs

Section 10.2 shall include:

**10.2. Instrument Parameters**

- 10.2.1. Instrument parameters setup stipulated in the SOPs, are instrument suggested parameters. Fine tune the instrument to obtain optimum instrument condition.
- 10.2.2. Print and staple a copy of the current instrument parameter on the instrument log for easy access when performing daily instrument routine check.
- 10.2.3. In the event that instrument parameters necessitate a change, replace the instrument parameter printout with the new parameter setup. Archive the previous instrument parameters at the back of the instrument maintenance log.

PREPARED BY:  Date: 9/11/19  
Name Farina Madamba  
Title QA / QC Coordinator

APPROVED BY:  Date: 09.11.19  
Name Kenette Pimentel  
Title QA Manager

APPROVED BY:  Date: 09-11-19  
Name Caspar Pang  
Title Laboratory Director

## STANDARD OPERATING PROCEDURES

TRACE METALS BY ICP-MS

SOP No.: EMAX-6020 Revision No. 10 Effective Date: 16-Nov-18

Prepared By: Tina Huang *[Signature]* Date: 11-15-18

Approved By: Kenette Pimentel *[Signature]* Date: 11-15-18  
QA Manager

Approved By: Caspar Pang *[Signature]* Date: 11-15-18  
Laboratory Director

**Control Number: 6020-10**

**1.0** SCOPE AND APPLICATION

- 1.1. This procedure is applicable for the determination of sub- $\mu\text{g/L}$  concentrations of a large number of elements in wastewater, groundwater, aqueous, extract, soil, sludge, and sediment samples using the Inductively Coupled Plasma-Mass Spectrometry (ICP-MS) method. All matrices require proper sample preparation prior to analysis.
- 1.2. The elements and their corresponding isotopes are listed in Table 1.
- 1.3. This SOP is an adaptation of the SW846 Method 6020A.

**2.0** SUMMARY OF METHOD

- 2.1. Metal analytes in water are acid digested from a pre-measured sample. Nitric acid and hydrochloric acid are added to the sample and heated without boiling until the volume is substantially reduced. The digestate is diluted back to its original sample volume using reagent water.
- 2.2. Metal analytes in soil are acid digested from a pre-measured sample. Nitric acid is added to the sample and heated to initialize digestion. It is further oxidized with 30% hydrogen peroxide and the acid used for final reflux is hydrochloric acid.
- 2.3. Digestates are introduced by pneumatic nebulization resulting aerosol into a high temperature argon plasma, where they are decomposed, atomized and ionized. The ions produced are extracted from the plasma via the sample and skimmer orifices in the interface region of the mass spectrometer. The extracted ions are guided by an off-axis Lens System to reduce background noise, passes through an Octopole Reaction System (ORS) where some ions require a simple reaction with  $\text{H}_2$  or He to eliminate matrix interference prior to entering the Quadrupole Mass Filter (QMF). The QMF separates ions based on their mass-to-charge ratios and ions are counted by electron multiplier detector.
- 2.4. Quantitation is accomplished by comparing the response of a major ion relative to an internal standard using a calibration curve.
- 2.5. **Interference**
  - 2.5.1. Isobaric Elemental Interference. Are caused by isotopes of different elements which form singly or doubly charge ions of the same nominal mass-to-charge ratio. The signal of an isotope of an interfering element is determined and subtracted from the analyte isotope signal.
  - 2.5.2. Isobaric Polyatomic Ion Interference. Are caused by ions consisting of more than one atom which have the same nominal mass-to-charge ratio as the isotope of interest. To correct for isobaric polyatomic ion interferences, optimize the cell gas pressure on each analyte so that when the ORS employs simple reaction gases ( $\text{H}_2$  and He) side reactions create new and unpredictable interferences. The ORS is equipped with notch filters and by using scanning voltages the created interferences are prevented from reaching the analyzer.

## STANDARD OPERATING PROCEDURES

**TRACE METALS BY ICP-MS**SOP No.: EMAX-6020 Revision No. 10 Effective Date: 16-Nov-18

- 2.5.3. **Physical Interference.** Nebulization and transport processes can be affected if a matrix component causes a change in surface tension or viscosity. An internal standard can be used to correct physical interference if carefully matched to the analyte so that the two elements are similarly affected by matrix changes. When the intensity level of the internal standard is less than 70% of the intensity of the first standard used during calibration, the sample must be diluted and re-analyzed.
- 2.5.4. **Memory Interference.** Contamination by carry-over can occur whenever high concentrations are analyzed in sequence with a low concentration sample. To reduce potential carry-over the rinse period between samples must be long enough to eliminate significant memory effect.

**3.0 DETECTION LIMITS****3.1. Detection Limit (DL), Limit of Detection (LOD) & Limit of Quantitation (LOQ)**

- 3.1.1. Refer to EMAX-QA04 for generation, validation and verification for DL, LOD and LOQ.
- 3.1.2. Established limits are shown in Table 5.

**4.0 DYNAMIC RANGE**

- 4.1. Linear Dynamic Range (LDR) is the concentration over which the instrument response remains linear.
- 4.2. Establish LDR of each analyte by determining the signal response from a minimum of three preferably five different concentration across the range. The upper limit should be within 10% ( $\pm 10\%$ ) of the true value.
- 4.3. Verify the established LDR every six months or when there is a significant change in the instrument signal, whichever comes first.

**5.0 SAMPLE HOLDING TIME AND PRESERVATION****5.1. Holding Time**

- 5.1.1. Analyze all samples within 180 days from collection date.

**5.2. Preservation**

- 5.2.1. Expected sample condition when received in the lab:
- water samples in HDPE or as specified by the project, preserved to pH < 2 with HNO<sub>3</sub>
  - soil samples in glass jar, brass tubes or as specified by the project
- 5.2.2. When water sample preservation is requested to be done in the lab, preserve the sample to pH < 2 with HNO<sub>3</sub> and observe at least 24 hours from the time preservative is added before sample digestion.
- 5.2.3. Store water samples in the same condition as received unless specified in the project requirement.
- 5.2.4. Store soil samples at  $\leq 6^{\circ}\text{C}$  without freezing.



## STANDARD OPERATING PROCEDURES

TRACE METALS BY ICP-MSSOP No.: EMAX-6020 Revision No. 10 Effective Date: 16-Nov-18

---

**6.0** ASSOCIATED SOPs

- |       |           |  |
|-------|-----------|--|
| 6.1.  | EMAX-DM01 | Data Flow and Review                             |
| 6.2.  | EMAX-QA04 | Detection Limit (DL)                             |
| 6.3.  | EMAX-QA05 | Training   |
| 6.4.  | EMAX-QA08 | Corrective Action                                |
| 6.5.  | EMAX-QC01 | Quality Control for Chemicals                    |
| 6.6.  | EMAX-QC02 | Analytical Standard Preparation                  |
| 6.7.  | EMAX-QC04 | Balance Calibration                              |
| 6.8.  | EMAX-QC05 | Calibration of Thermometers                      |
| 6.9.  | EMAX-QC06 | Volumetric Labware and Micropipette Verification |
| 6.10. | EMAX-QC07 | Glassware Cleaning                               |
| 6.11. | EMAX-SM03 | Waste Disposal                                   |
| 6.12. | EMAX-SM04 | Analytical and QC Sample Labeling                |

**7.0** SAFETY

- 7.1. Read all SDS of chemicals listed in this SOP.
- 7.2. Observe the following precautions during operation or maintenance of the instrument:
  - Close the instruments hoods and panels prior to operation.
  - Check the exhaust system for a positive extraction at the exhaust duct.
  - Handle acids properly.
  - Check the drain vessels frequently.
  - Make sure that the argon tank is chained.
  - Wait for the instrument interface region to cool down prior to instrument maintenance.
  - Observe all cautions and warnings stipulated in the Agilent 7500 ICPMS CE/CX Manuals.
- 7.3. Treat all reagents, standards, and samples as potential hazards. Observe the standard laboratory safety procedures. Wear protective gear, i.e., lab coat, safety glasses, gloves, at all times when performing this procedure. Observe all chemical hygiene procedures as mentioned in the Chemical Hygiene Plan.
- 7.4. DO NOT DISPOSE ACIDIC WASTE IN THE TRASH CAN OR IN THE SINK.
- 7.5. If for any reason, solvent and/or other reagents get in contact with the skin or any other part of the body, rinse the affected body part thoroughly with tap water. If irritations persist, inform your supervisor immediately so that proper action can be taken.

**8.0** INSTRUMENTS, CHEMICALS AND REAGENTS**8.1. Instruments and Supplies**

- 8.1.1. ICP-MS: Agilent 7500CE Octopole Reaction System : Agilent 7500CX Octopole Reaction System

## STANDARD OPERATING PROCEDURES

TRACE METALS BY ICP-MSSOP No.: EMAX-6020 Revision No. 10 Effective Date: 16-Nov-18

- 
- 8.1.2. Autosampler: CETAC ASX-520
  - 8.1.3. Computer: IBM Compatible
  - 8.1.4. RF Generator: Agilent RF Generators
  - 8.1.5. Data Acquisition: Agilent Chemstation version B.03.04 or as updated : Agilent Chemstation version B.04.00 or as updated
  - 8.1.6. Autosampler rack(s): 17 x 100 mm, 60 positions
  - 8.1.7. Culture tubes: 17 x 100 mm, polypropylene
  - 8.1.8. Volumetric Flask: 10 mL, 50 mL, 500 mL, 1000 mL
  - 8.1.9. Micropipettes: 1 mL, 0.100 mL, 5 mL
  - 8.1.10. Pipet Tips: 100 - 1000 µL
  - 8.1.11. Polyethylene bottles: 250, 500, 1000 mL
  - 8.1.12. Liquid argon
  - 8.1.13. Hydrogen, Compressed: Ultra-high purity
  - 8.1.14. Helium, compressed: Ultra-high purity
  - 8.1.15. Balance: Sartorius LC 620 S or equivalent
  - 8.1.16. Spatula: Stainless steel or equivalent
  - 8.1.17. Digestion vessel: 50 mL, 100 mL snap seal
  - 8.1.18. Digestion block: Aluminum blocks or equivalent
  - 8.1.19. Thermometer: Range 0 – 110°C
  - 8.1.20. Filter: Whatman #41 or equivalent
  - 8.1.21. Digestate Container: 50 mL polyethylene vessel, 100 mL Corning snap seal or equivalent
  - 8.1.22. Disposable watch glass
  - 8.1.23. ASX press Rapid Sample Introduction System

**8.2. Chemicals and Reagents**

- 8.2.1. DI water, ASTM Type II or equivalent
- 8.2.2. Nitric Acid, Trace high purity grade, concentrated
- 8.2.3. Hydrochloric acid, Trace high purity grade, concentrated
- 8.2.4. Hydrogen Peroxide, ACS grade (e.g., VW3690-5 from VWR) or equivalent
- 8.2.5. Matrix Acid Blank (S0) - Prepare matrix acid solution by mixing 3% by volume nitric acid and 1% by volume hydrochloric acid in DI water. Transfer into a clean HDPE bottle and identify the solution as S0. Use this solution for standards or digestate dilutions.

## STANDARD OPERATING PROCEDURES

**TRACE METALS BY ICP-MS**SOP No.: EMAX-6020 Revision No. 10 Effective Date: 16-Nov-18**9.0 STANDARDS****9.1. Internal Standard (IS)**

9.1.1. Purchase stock internal standard as certified standard at concentration listed below or equivalent.

| STANDARD | SOURCE  | ELEMENTS                        | CONC. (mg/L) | MATRIX               |
|----------|---------|---------------------------------|--------------|----------------------|
| IS       | Agilent | Li6, Sc, Ge, Rh, In, Tb, Bi, Lu | 100          | 10% HNO <sub>3</sub> |

**9.2. Tune Check Standard**

| STANDARD                    | SOURCE               | ELEMENTS          | CONC. (mg/L) | MATRIX              |
|-----------------------------|----------------------|-------------------|--------------|---------------------|
| Tuning Solution             | Agilent              | Li, Y, Ce, Tl, Co | 0.01         | 2% HNO <sub>3</sub> |
| Tuning Check Standard (TCS) | High Purity Standard | Co, In, Li, Tl    | 10           | 2% HNO <sub>3</sub> |

9.2.1. Prepare tuning check standard at concentration level suggested below.

| STANDARD                                  | TCS Aliquot (mL) | Final volume (mL) | Final Concentration (mg/L) |
|---|------------------|-------------------|----------------------------|
| Intermediate tuning check standard (ITCS) | 0.5              | 50                | 0.100                      |

**9.3. Primary Standards****9.3.1. Stock Standards**

9.3.1.1. Purchase certified stock standards as listed in the table below or equivalent.

| STOCK STANDARD | SOURCE                           | ELEMENTS   | CONC. (mg/L) | MATRIX                                |
|----------------|----------------------------------|--|--------------|---------------------------------------|
| ICAL 1         | High Purity                      | As, B, Se, Sr, Tl, Ti, V, Zn, Sb, Mo, Sn         | 10           | 2% HNO <sub>3</sub> and Trace HF Acid |
| ICAL 2         | High Purity                      | Ba, Be, Cd, Cr, Co, Cu, Pb, Li, Mn, Ni, Ag, U    | 10           | 2% HNO <sub>3</sub>                   |
| ICAL 3         | High Purity                      | Al, Fe, K, Ca, Mg, Na                            | 1000         | 4% HNO <sub>3</sub>                   |
| ICAL 4         | High Purity                      | Al, AS, B, Ba, Be, Ca, Cd, Co, Cr, Cu, Fe, Pb, K | 500          | 2% HNO <sub>3</sub>                   |
| ICAL 5         | High Purity                      | Ag, Mo, Sb, Si, Sn, Ti                           | 0.50         | 2% HNO <sub>3</sub> and Trace HF Acid |
| Phosphorus     | AccuStandard                     | P  | 100          | Water                                 |
| Silicon        | High Purity                      | Si   | 1000         | Water Trace HF                        |
| Tungsten       | AccuStandard<br>Ultra Scientific | W  | 100          | Water and trace NH <sub>4</sub> OH    |

## STANDARD OPERATING PROCEDURES

**TRACE METALS BY ICP-MS**SOP No.: EMAX-6020 Revision No. 10 Effective Date: 16-Nov-18

| STOCK STANDARD      | SOURCE       | ELEMENTS   | CONC. (mg/L) | MATRIX                |
|---------------------|--------------|--|--------------|-----------------------|
| Zinc                | High Purity  | Zn   | 1000         | 2% HNO <sub>3</sub>   |
| Zirconium           | AccuStandard | Zr   | 100          | 2-5% HNO <sub>3</sub> |
| Individual Elements | AccuStandard | As Ba Be B Cd Cr Co Cu<br>Pb Li Mn Mo Se Ag Sr Tl<br>Ti U V Zn | 1000         | 5% HNO <sub>3</sub>   |
|                     |              | Al Fe Ca Mg K Na Sn Sb   | 10000        |                       |

9.3.2. Intermediate Standard

9.3.2.1. Prepare intermediate standards using the standards as suggested below and S0. Other concentrations may also be prepared at the discretion of the analyst.

| Standard Name | Stock Standard Name | Conc. (mg/L) | Source       | Preparation  |                 |                    |
|---------------|---------------------|--------------|--------------|--------------|-----------------|--------------------|
|               |                     |              |              | Aliquot (mL) | Final vol. (mL) | Final conc. (µg/L) |
| Cation Mix    | Al                  | 10,000       | AccuStandard | 2.5          | 500             | 50000              |
|               | Ca                  | 10,000       | AccuStandard | 2.5          |                 | 50000              |
|               | Fe                  | 10,000       | AccuStandard | 2.5          |                 | 50000              |
|               | Mg                  | 10,000       | AccuStandard | 2.5          |                 | 50000              |
|               | K                   | 10,000       | AccuStandard | 2.5          |                 | 50000              |
|               | Na                  | 10,000       | AccuStandard | 1.25         |                 | 25000              |
| Trace mix     | ICAL 1              | 10           | High Purity  | 5            | 10              | 5000               |
|               | ICAL 2              | 10           | High Purity  | 5            |                 |                    |
| Mix 7A        | ICAL 1              | 10           | High Purity  | 1            | 10              | 1000               |
|               | ICAL 2              | 10           | High Purity  | 1            |                 | 1000               |
|               | ICAL 3              | 1000         | High Purity  | 1            |                 | 100000             |
| Si-10         | Si                  | 1000         | AccuStandard | 0.1          | 10              | 10000              |
| W-1           | W                   | 1000         | AccuStandard | 0.5          | 50              | 1000               |
| Zn-1          | Zn                  | 1000         | High Purity  | 0.05         | 50              | 1000               |
| Zr-1          | Zr                  | 100          | AccuStandard | 0.5          | 50              | 1000               |
| Sr-1          | Sr                  | 1000         | AccuStandard | 0.05         | 50              | 1000               |

9.3.3. Initial Calibration Standard

9.3.3.1. The initial calibration consists of a blank (S0) and four standards (S1, S2, S3 and S4). Prepare the standards as suggested in Table 2 unless otherwise specified by the project. Refer to Table 3 for final concentrations for each analyte. Additional standard points may be added at the discretion of the analyst or as required by the project.

## STANDARD OPERATING PROCEDURES

**TRACE METALS BY ICP-MS**SOP No.: EMAX-6020 Revision No. 10 Effective Date: 16-Nov-189.3.4. Continuing Calibration Verification (CCV) Standard

9.3.4.1. Prepare CCV using the stock standards and S0 as suggested in Table 2 or as required by the project. Refer to Table 3 for final concentrations for each analyte.

9.3.4.2. Prepare intermediate solution for Low Level CCV (LLCCV) using the stock standards and S0 as suggested in Table 2 or as required by the project. Refer to Table 3 for final concentrations of each analyte.

9.4. **P/A Tuning Standard (PATS)**

9.4.1. Using the calibration stock standard from 9.3.1, IS from 9.2.1 and S0, prepare a 50 µg/L and 100 µg/L mixed standard to a final volume of 100 mL.

| STANDARD   | Aliquot (mL) | CONC. (µg/L) | Aliquot (mL) | CONC. (µg/L) |
|------------|--------------|--------------|--------------|--------------|
| ICAL 1     | 0.5          | 50           | 1            | 100          |
| ICAL 2     | 0.5          |              | 1            |              |
| ICAL 3     | 0.005        |              | 0.01         |              |
| Phosphorus | 0.5          |              | 0.1          |              |
| Silicon    | 0.5          |              | 0.1          |              |
| Tungsten   | 0.5          |              | 0.1          |              |
| Zinc       | 0.05         |              | 0.1          |              |
| Zirconium  | 0.05         |              | 0.1          |              |
| IS         | 0.05         |              | 0.1          |              |

9.5. **Secondary Source Standard**9.5.1. Secondary Stock Standard

9.5.1.1. Purchase certified secondary stock standards from a different vendor that contains all analytes as listed in primary stock standards or as listed below.

| Standard            | Source             | Elements  | Conc. (mg/L) | Matrix                      |
|---------------------|--------------------|---|--------------|-----------------------------|
| EMAX Mix 2 (ICV1)   | High Purity        | As, Ba, Be, B, Cd, Cr, Co, Cu, Pb, Mn, Ni, Se, Sr, Tl, Ti, V, Zn, Ag, Sb, Mo, Li, U, Sn | 10           | 5% HNO <sub>3</sub> + Tr HF |
| EMAX Mix 3 (ICV2)   | High Purity        | Al, Fe, Ca, Mg, K, Na   | 10000        | 5% HNO <sub>3</sub>         |
| Phosphorus          | CPI                | P   | 100          | 0.05% HNO <sub>3</sub>      |
| Silicon             | High Purity        | Si  | 1000         | Water Trace HF              |
| Tungsten            | Ultra Scientific   | W   | 100          | Water                       |
| Zirconium           | CPI                | Zr  | 100          | 2% HNO <sub>3</sub>         |
| Individual Elements | CPI                | Sb As Ba Be B Cd Cr Co Cu Pb Li Mn Mo<br>Se Ag Sr Tl Sn Ti U V Zn                       | 1000         | 5% HNO <sub>3</sub>         |
|                     |                    | Al Fe Ca Mg K Na  | 10000        |                             |
| 6020ICS-0A          | Inorganic Ventures | Al, Ca, Fe, Mg, Na, P, K, S   | 1000         | 1.4% HNO <sub>3</sub>       |
|                     |                    | C   | 2000         |                             |
|                     |                    | Cl  | 10000        |                             |
|                     |                    | Mo, Ti  | 20           |                             |

## STANDARD OPERATING PROCEDURES

**TRACE METALS BY ICP-MS**SOP No.: EMAX-6020 Revision No. 10 Effective Date: 16-Nov-189.5.2. Secondary Intermediate Standard

9.5.2.1. Prepare a Cation Mix 2 using secondary source individual stock standard and S0 as suggested below to a final volume of 500 mL.

| Standard     | Element | Stock Conc. (mg/L) | Source           | Aliquot (mL) | Final Conc. (µg/L) |
|--------------|---------|--------------------|------------------|--------------|--------------------|
| Cation Mix 2 | Al      | 10,000             | CPI              | 2.5          | 50000              |
|              | Ca      | 10,000             | CPI              | 2.5          | 50000              |
|              | Fe      | 10,000             | CPI              | 2.5          | 50000              |
|              | Mg      | 10,000             | CPI              | 2.5          | 50000              |
|              | K       | 10,000             | CPI              | 2.5          | 50000              |
|              | Na      | 10,000             | CPI              | 1.25         | 25000              |
| Tungsten     | W       | 1000               | Ultra Scientific | 0.5          | 1000               |

9.6. **Initial Calibration Verification (ICV)**

9.6.1. Prepare ICV using the secondary stock standards, Cation Mix 2 and S0 as suggested in Table 2. Refer to Table 3 for final concentrations for each analyte.

9.7. **Interference Standards (ICSA/ICSAB)**

9.7.1. Prepare Intermediate ICSA and ICSAB standards at concentration levels suggested below. Refer to Table 3 final concentrations.

| Standard           | Parent Standard | Aliquot (mL) | Final Volume (mL) | Final Concentration (µg/L) |
|--------------------|-----------------|--------------|-------------------|----------------------------|
| Intermediate ICSA  | 6020ICS-0A      | 5            | 50                | Varied                     |
| Intermediate ICSAB | 6020ICS-0A      | 5            | 50                | Varied                     |
|                    | ICAL 1          | 0.10         |                   |                            |
|                    | ICAL 2          | 0.10         |                   |                            |
|                    | Zr              | 0.010        |                   |                            |
|                    | W               | 0.010        |                   |                            |

9.8. **LCS/MS Spike Standard**

9.8.1. Prepare LCS/MS standards as suggested below or as required by the project.

| STANDARD   | SOURCE        | ELEMENTS  | CONC. (mg/L) | MATRIX                      |
|------------|---------------|---|--------------|-----------------------------|
| ICV 1      | High Purity   | B, Sr, As, Ba, Be, Ag, Cd, Cr, Co, Cu, Tl, Pb, Mn, Ni, Se, V, Zn, Ti, Sb, Mo, Li, U, Sn | 10           | 5% HNO <sub>3</sub> + Tr HF |
| ICV 2      | High Purity   | Al, Fe, Ca, Mg, K, Na   | 1000         | 5% HNO <sub>3</sub>         |
| Phosphorus | CPI           | P   | 1000         | 0.05% HNO <sub>3</sub>      |
| Silicon    | High Purity   | Si  | 1000         | Water Trace HF              |
| Zirconium  | CPI           | Zr  | 100          | 2% HNO <sub>3</sub>         |
| Tungsten   | Accu Standard | W   | 100          | Water                       |

## STANDARD OPERATING PROCEDURES

**TRACE METALS BY ICP-MS**SOP No.: EMAX-6020 Revision No. 10 Effective Date: 16-Nov-18

9.9. Refer to EMAX-QC02 for detailed procedure of standard preparation and labeling.

**10.0 PROCEDURES****10.1. Sample Preparation****10.1.1. Water Samples**

- 10.1.1.1. Based from the work order, determine the samples to form a preparative batch (not to exceed 20 samples per preparative batch). Withdraw the sample(s) from the sample control room and bring them to the preparation area. Allow the samples to equilibrate at room temperature.
- 10.1.1.2. Shake the sample container. Pour a small amount of sample into the sample cap and trickle just enough to wet the pH indicator strip. Compare the color of the wet strip to the indicator chart displayed in the pH indicator box. Record the pH in the digestion log. If the pH value is  $<2$ , proceed to 10.1.3. If the pH value is  $\geq 2$ , check if special instruction is written on the analysis folder or in the COC. Otherwise, fill out an NCR and inform the supervisor immediately. DO NOT PROCEED WITH THE DIGESTION. WAIT FOR FURTHER INSTRUCTION.
- 10.1.1.3. Line up the samples chronologically under the hood. Check and record the lot number of the digestion vessels if it has been verified for accuracy. Take digestion vessels and label each one corresponding to the samples withdrawn and place them in front of each sample making sure that their labels agree. Take four more vessels and label them as preparation blank, LCS, matrix spike and matrix spike duplicate.
- 10.1.1.4. Mix the sample thoroughly to achieve homogeneity. Fill each digestion vessel up to the 50 mL mark. (The reduction of the volume is due to waste minimization).
- 10.1.1.5. Record the volume in the digestion log. Use reagent water for blank and LCS.
- 10.1.1.6. Take another digestion vessel; fill it with tap water to 50 mL mark. Put a thermometer inside and let it sit on the digestion block. Turn the thermostat to a pre-determined mark to deliver heat at 90-95°C. Record the temperature reading in the digestion log.
- 10.1.1.7. **Spike Addition**
- 10.1.1.7.1. Call for a witness for spike addition. Have the witness verify the setting of the micropipette and the expiration dates of the spike standards.
- 10.1.1.7.2. Spike LCS and MS samples with 0.15 mL of EMAX MIX 2 and 3 (see Section 9.5.1) solutions. Additional elements are listed below to be spiked only when required by the project.

| Analyte    | Concentration(mg/L) | Spike Amount(mL) |
|------------|---------------------|------------------|
| Phosphorus | 1000                | 0.015            |
| Silicon    | 1000                | 0.150            |
| Tungsten   | 1000                | 0.015            |
| Zirconium  | 1000                | 0.01             |

## STANDARD OPERATING PROCEDURES

**TRACE METALS BY ICP-MS**SOP No.: EMAX-6020 Revision No. 10 Effective Date: 16-Nov-18

---

**10.1.1.8. Acid Digestion for Dissolved Metals**

- 10.1.1.8.1. Add 0.5 mL of concentrated HNO<sub>3</sub> and 0.25 mL concentrated HCl to each of the digestion vessels.
- 10.1.1.8.2. Cap the digestion vessels with disposable watch glass.
- 10.1.1.8.3. Check that the temperature of the digestion block is 90-95°C (covered vessel) and adjust if necessary.
- 10.1.1.8.4. Place the digestion vessels on the digestion block and reduce volume of sample by continuous heating without boiling for two hours.
- 10.1.1.8.5. Reflux gently for another 15 minutes. Remove the digestion vessels from the digestion plate and allow the vessels to cool down.
- 10.1.1.8.6. Using a reagent water wash bottle, rinse the disposable watch glass collecting the rinsate on the same digestion vessel that it covered. Add 1.0 mL concentration HNO<sub>3</sub> and 0.25 mL concentration HCl for matrix matching.
- 10.1.1.8.7. Dilute the digestate with reagent water to the 50 mL mark of the digestion vessel. Seal the vessel and shake. If the digestate appears to be turbid, pass it through Whatman #41 filter and collect it in a new polyethylene container.

**10.1.1.9. Acid Digestion for Total Recoverable Metals**

- 10.1.1.9.1. Add 0.5 mL of concentrated HNO<sub>3</sub> and 0.25 mL concentrated HCl to each of the digestion vessels.
- 10.1.1.9.2. Cap the digestion vessels with disposable watch glass.
- 10.1.1.9.3. Check that the temperature of the digestion block is 90-95°C (covered vessel) and adjust if necessary.
- 10.1.1.9.4. Place the digestion vessels on the digestion block and reduce volume of sample by continuous heating without boiling for two hours.
- 10.1.1.9.5. Reflux gently for another 15 minutes. Remove the digestion vessels from the digestion block and allow the vessels to cool down.
- 10.1.1.9.6. Using a reagent water wash bottle, rinse the disposable watch glass collecting the rinsate on the same digestion vessel that it covered. Add 1.0 mL concentration HNO<sub>3</sub> and 0.25 mL concentration HCl for matrix matching.
- 10.1.1.9.7. Dilute the digestate with reagent water to the 50 mL mark of the digestion vessel. Seal the vessel and shake. If the digestate appears to be turbid, pass it through Whatman #41 filter and collect it in a new polyethylene container.

**10.1.2. Soil Samples****10.1.2.1. Sample Handling**

- 10.1.2.1.1. Based from the work order, determine the samples to form a preparative batch (not to exceed 20 field samples). Withdraw the sample(s) from the



## STANDARD OPERATING PROCEDURES

**TRACE METALS BY ICP-MS**SOP No.: EMAX-6020 Revision No. 10 Effective Date: 16-Nov-18

sample control room designated for metals analysis (passing # 10 sieve) and bring them to the weighing area. Allow the samples to equilibrate at room temperature.

*Note: Sample homogeneity is crucial in metals analysis. If sample is not solely designated for metals analysis (i.e., sample is to be used for other analysis) and it is apparent that sample particles contain > #10 sieve, inform the Supervisor for further instruction.*

- 10.1.2.1.2. Take digestion vessels and label each one corresponding to the samples withdrawn. Take four more vessels and label them as preparation blank, LCS, matrix spike and matrix spike duplicate.
- 10.1.2.1.3. Check project sub-sampling requirement. If multi-incremental sub-sampling (MIS) is required, refer to EMAX-SM01, section 5.13.2 for details. Otherwise follow the steps described in EMAX-SM01, section 5.13.1.
- 10.1.2.1.4. Scoop 1-2 g sub-sample and transfer into a properly labeled digestion vessel. Record the weight to the nearest 0.01 g.

**10.1.2.2. Pre-heating the Digestion Block**

- 10.1.2.2.1. Place a digestion vessel with reagent water and a temperature monitoring thermometer on the digestion block.
- 10.1.2.2.2. Turn the digestion block on and set the thermostat to 95°C or to a predetermined temperature to obtain 95°C(±5°C) once the digestion vessel is covered with a watch glass.
- 10.1.2.2.3. When the temperature reading is 95°C(±5°C), the digestion block is now ready for digestion.

**10.1.2.3. Spike Addition**

- 10.1.2.3.1. Call for a witness for spike addition. Have the witness verify the setting of the micropipette and the expiration dates of the spike standards.
- 10.1.2.3.2. Spike LCS and MS samples with 4 mL of EMAX MIX 2 & 3 (Sec. 9.5.1) to LCS and MS samples. Additional elements are listed below to be spiked only when required by the project.

| Analyte    | Concentration(mg/L) | Spike Amount(mL) |
|------------|---------------------|------------------|
| Phosphorus | 1000                | 0.5              |
| Tungsten   | 1000                | 0.5              |
| Zirconium  | 1000                | 0.3              |

**10.1.2.4. Acid Digestion**

- 10.1.2.4.1. Add 10 mL of reagent water and 5 mL of concentrated HCL<sup>1</sup> into each vessel, swirl the vessel to mix the acid and the sample. Add same

<sup>1</sup> Addition of 5 mL HCl is a modification from Method 3050B to enhance recovery of antimony. Refer to Appendix 3 for the comparative study done on ICP-MS.

## STANDARD OPERATING PROCEDURES

**TRACE METALS BY ICP-MS**SOP No.: EMAX-6020 Revision No. 10 Effective Date: 16-Nov-18

amount of acid into a clean and empty vessel and designate it as blank. Insert the vessels in the digestion block(s). Cap the vessels with conical watch glass.

- 10.1.2.4.2. Check the temperature of the digestion block 95°C(±5°C), adjust if necessary. If temperature happens to be ≥ 100°C, adjust the thermostat and wait until temperature falls within 95°C(±5°C). Record the temperature reading in the digestion log.
- 10.1.2.4.3. Place the digestion vessels on the digestion block and reflux for 15 minutes without boiling.
- 10.1.2.4.4. Transfer the vessels into unheated digestion block and allow the vessels to cool down for at least 5 minutes. Lift the watch glass and add 10-mL of concentrated HNO<sub>3</sub>. Place the watch glass back before working on the next vessel.
- 10.1.2.4.5. Return the vessels to the digestion block and reflux for another 15 minutes.
- 10.1.2.4.6. Transfer the vessels into unheated digestion blocks and allow the vessels to cool down for at least 5 minutes. Lift the water glass and add 10 mL 1:1 HNO<sub>3</sub>. Place the water glass back before working on the next vessel.
- 10.1.2.4.7. Return the vessels to the digestion block and reflux for another 15 minutes.
- 10.1.2.4.8. Transfer the vessels into unheated digestion blocks and allow the vessels to cool down for at least 5 minutes.
- 10.1.2.4.9. Add 2 mL of reagent water. Then add 3 mL of 30% hydrogen peroxide (H<sub>2</sub>O<sub>2</sub>) to each vessel, swirling each one of them after every addition to initiate peroxide reaction. Continue to add H<sub>2</sub>O<sub>2</sub> until the amount added reaches 10 mL.
- 10.1.2.4.10. Return the vessels to the heated digestion block. Care must be taken to ensure that losses do not occur due to excessive effervescence.
- 10.1.2.4.11. Continue to reflux the mixture at 95°C(±5°C) for 15 minutes. Remove the digestion vessels from the digestion block and allow the vessel to cool down for at least 5 mins.
- 10.1.2.4.12. Lift the watch glass, add 5 mL of concentrated HCl. Swirl the vessel until added reagents are properly mixed with the solution. Place the watch glass before working on the next vessel. Return the vessels into the heated digestion block. Reflux for additional 15 minutes. Subsequently, remove the digestion vessels from the digestion block and allow the vessels to cool down and dilute to 100 mL final volume with reagent water.
- 10.1.2.4.13. Let the digestate settle and centrifuge or filter with Whatman #41 (see 10.1.5) if necessary otherwise digestates are now ready for analysis.

**10.1.2.5. Digestate Filtration**

- 10.1.2.5.1. Place Whatman #41 filter paper into each funnel resting on holders.

## STANDARD OPERATING PROCEDURES

**TRACE METALS BY ICP-MS**SOP No.: EMAX-6020 Revision No. 10 Effective Date: 16-Nov-18

---

Rinse the filter papers with reagent water.

- 10.1.2.5.2. Place a pre-labeled digestate container under each funnel making sure that the labels are visible.
- 10.1.2.5.3. Check the labels to make sure that they agree. Pour the digestate into the filter.
- 10.1.2.5.4. Filter and collect the digestates in the labeled container. The digestates are now ready for analysis.

**10.2. Instrument Parameters**

10.2.1. Set instrument parameters as suggested below.

**10.2.2. Plasma Condition**

- RF Power: 1500 W
- RF Matching: 1.68 V
- Sample Depth: 8.0 mm
- Torch Height: -0.4 mm
- Torch Vertical: 0 mm
- Carrier Gas: 0.9 L/min
- Make-up Gas: 0.15 L/min Note: Total Carrier and Make-up gas not to exceed 1.1 L/min.
- Peristaltic pump: 0.1 rps
- Spray Chamber (S/C) Temp: 2°C

**10.2.3. Ion Lenses**

- Extract 1: 0 V
- Extract 2 : -140V
- Omega Bias-ce: -22 V
- Omega Lens-ce: -1.2 V
- Cell Entrance: -26 V
- QP Focus: 2 V
- Cell Exit: -30 V

**10.2.4. Octopole Parameters**

- Octopole RF: 150 V
- Octopole Bias: -6 V

**10.2.5. Q-Pole Parameters**

- AMU Gain: 127
- AMU Offset: 125

## STANDARD OPERATING PROCEDURES

TRACE METALS BY ICP-MSSOP No.: EMAX-6020 Revision No. 10 Effective Date: 16-Nov-18

- Axis Gain: 0.9996
- Axis Offset: 0.04
- QP Bias: -3 V

10.2.6. Detector Parameters

- Discriminator: 8 mV
- Analog HV: 1630 V
- Pulse HV: 990 V

10.2.7. Reaction Cell

- H<sub>2</sub> Gas: 3.0 mL/min
- He Gas: 4 mL/min

10.2.8. Adjust the instrument parameters to optimize the instrument performance in conformance to the tuning requirement.

10.2.9. Print the most current instrument parameters and place in the appropriate binder for easy reference. Replaced instrument parameter set-up should be archived chronologically for future reference and historical record.

10.3. **Calibration**10.3.1. Instrument Set-Up

10.3.1.1. Set up the ICP-MS with proper operating parameters. Refer to Section 10.3.

10.3.1.2. Ignite the plasma and allow the instrument to become thermally stable for at least 30 minutes.

10.3.1.3. Check the peristaltic pump to deliver a steady flow.

10.3.2. Tuning the Instrument

10.3.2.1. Tune the instrument according to Normal Mode, Hydrogen Mode and Helium Mode without the internal standard. Refer to Section 10.3 for parameters. On the ICP-MS main Menu, go to Instrument and click Tune and run the tuning solution without the internal standard. After about 60 seconds (making sure the solution is in the system) click start and evaluate the counts of the isotopes according to the table below.

| Mode     | Range             |                    |                     |
|----------|-------------------|--------------------|---------------------|
| Normal   | Li6 ≥ 6400 counts | Y89 ≥ 16000 counts | Tl205 ≥ 9600 counts |
| Hydrogen | Ar/Ar78 < 10      | Y89 ≥ 3000 counts  |                     |
| Helium   | V51/Co59 < 0.6    | Co59 ≥ 7000 counts | ArCl-75 < 10 counts |

10.3.2.2. If non-compliant, adjust parameters (e.g. Torch height, Torch vertical, Octopole Bias and QP Bias) and repeat the tune process until the required range is met.

10.3.2.3. Click Generate report for a full scan of the tune. Save all tune values to the current method.

## STANDARD OPERATING PROCEDURES

TRACE METALS BY ICP-MSSOP No.: EMAX-6020 Revision No. 10 Effective Date: 16-Nov-18

---

10.3.3. Perform a P/A Factor Evaluation

- 10.3.3.1. Analyze the 50 µg/L P/A tuning standard.
- 10.3.3.2. Under "Tune," access "P/A Factor." Select "Load masses from the acquisition method". Subsequently, highlight and delete Ca, (Cd)<sup>106</sup>, (Cd)<sup>108</sup>, (Pb)<sup>206</sup>, (Pb)<sup>207</sup> from the list of elements, then select "run."
- 10.3.3.3. Upon completion, accept the changes.
- 10.3.3.4. Accept the new P/A Factors and save file as "norm.u".
- 10.3.3.5. Similarly, analyze the 100 ug/L P/A tuning standard as described above, with the check box for "Merge current data" enabled.

10.3.4. Perform Tune Check

- 10.3.4.1. Analyze the intermediate tune check solution (9.1.1) using 4 replicates.
- 10.3.4.2. Evaluate the tune check so that the mass calibration differs no more than 0.1 AMU of the true value and the resolution to be less than 0.9 AMU full width at 10% peak height RSD should less than or equal to 5% for the 4 replicate analysis.

10.3.5. Initial Calibration (ICAL)

- 10.3.5.1. Set the instrument rinse time to 90 seconds between each standard solution.
- 10.3.5.2. Analyze a calibration blank (S0) and a multi-point calibration standard (Section 9.3.3.1).
- 10.3.5.3. Refer to Appendix 1 for ICAL acceptance criteria and /or corrective action.

10.3.6. Initial Calibration Verification (ICV)/ Instrument Calibration Blank (ICB)

- 10.3.6.1. Analyze the ICV (Section 9.5.1) from a second source to verify the concentration of the ICAL.
- 10.3.6.2. Analyze a low-level ICV (LLICV) from the same source as the calibration standard to verify the lower limit of quantitation (RL).
- 10.3.6.3. Analyze an ICB after LLICV to demonstrate absence of instrument contamination.
- 10.3.6.4. Refer to Appendix 1 for ICV, LLICV and ICB acceptance criteria and /or corrective action.

10.3.7. Continuing Calibration Verification (CCV)/ Continuing Calibration Blank (CCB)

- 10.3.7.1. Analyze CCV to check the validity of the ICAL every 10 samples and at the end of the analytical sequence.
- 10.3.7.2. Analyze low-level CCV (LLCCV) to check the system stability at low end of ICAL at the end of the analytical sequence.
- 10.3.7.3. Analyze a CCB every after LLCCV to demonstrate the absence of instrument contamination.
- 10.3.7.4. Refer to Appendix 1 for CCV, LLCCV and CCB acceptance criteria and/or corrective action.

10.3.8. ICSA and ICSAB

- 10.3.8.1. Analyze ICSA and ICSAB at the beginning of each analytical run and every 12 hours thereafter.

## STANDARD OPERATING PROCEDURES

TRACE METALS BY ICP-MSSOP No.: EMAX-6020 Revision No. 10 Effective Date: 16-Nov-18

---

10.3.9. Establishing Instrument Detection Limit (IDL)

- 10.3.9.1. Analyze a minimum of seven consecutive method blanks.
- 10.3.9.2. Repeat the process within three non-consecutive days.
- 10.3.9.3. Calculate the standard deviation of each run.
- 10.3.9.4. The average of the standard deviation of the three runs determines the IDL for each analyte.
- 10.3.9.5. Establish IDL at least every 3 months.

10.3.10. Verifying Linear Dynamic Range (LDR)

- 10.3.10.1. Verify the LDR by preparing a standard at the upper limit of the LDR. Analyze and quantitate against the normal calibration curve. Percent recovery must be within  $\pm 10\%$  of expected value. If non-complaint re-establish LDR.
- 10.3.10.2. At a minimum perform LDR verification every six months.

**10.4. Analysis**10.4.1. Analytical Sequence

- 10.4.1.1. From the main menu of the ICPMS top window, go to Sequence and create the analytical sequence by editing the sample log table. Refer to Table 4.
- 10.4.1.2. Set QC limits on QC samples for easy verification while analytical samples are running.
- 10.4.1.3. Using the sample log table, input the standards and the digestates to be analyzed. Samples are analyzed in the order they appear in the scanner.
- 10.4.1.4. Transfer about 5 mL of its content into the autosampler tubes placing them on the autosampler rack in the same order as the analytical sequence. A dilution of x10 for soil samples is required due to the high acid content of the digestate.
- 10.4.1.5. Dilution Test sample is prepared at 5 times dilution. Seal the tube with Parafilm and invert the tube several times to ensure adequate mixing.
- 10.4.1.6. Prepare a Post Digestion Spike test sample. Using the un-spiked sample digestate (preferably the QC sample), add MS standard to maintain the same spike level as the MS sample digestate.
- 10.4.1.7. A 100  $\mu\text{g/L}$  internal standard shall be spiked into each sample.
- 10.4.1.8. Set the prepared analytical samples into the auto-sampler and start the analytical run.

10.4.2. Sample Result Evaluation

- 10.4.2.1. Check QC parameters as soon as the data is available.
  - Check the initial calibration verification (ICV, LLICV and ICB) against Appendix 1.
  - Check MB, LCS against Appendix 1. Perform specified corrective action if necessary.
  - Check the MS, duplicate sample, serial dilution and post digestion spike results. If matrix interference is indicated, dilute the sample and re-analyzed.
  - Check intensity of internal standard on each sample.

## STANDARD OPERATING PROCEDURES

TRACE METALS BY ICP-MSSOP No.: EMAX-6020 Revision No. 10 Effective Date: 16-Nov-18

- If any of the above checkpoints is non-compliant, perform the specified corrective action in Appendix 1. If results indicate digestion problem, order re-digestion for affected samples. If unresolved, consult the Supervisor for further action.

10.4.2.2. Check the sample rack to ensure that the Autosampler did not skip any sample.

10.4.2.3. Check concentration of target analytes. If the response exceeds LDR, dilute and reanalyze the sample at a concentration within the LDR.

10.4.2.4. Check other QC requirements like ICSA, ICSAB, CCV, LLCCV, CCB against Appendix 1.

**10.5. Calculations**

10.5.1. The computer software is designed to calculate the concentration in the digestate, based on the assumption that the initial calibration is linear through the origin. Thus, for aqueous samples, the computer-generated result represent the concentration of the sample.

10.5.2. For water samples

$$C_s = C_i \left( \frac{ExpAmt}{Aliquot} \right) \left( \frac{V_d}{ExpVd} \right) DF \quad \text{Eq.-10.5.2}$$

where:

$C_s$  – Concentration in the sample, µg/L

$C_i$  – Concentration in the digestate, (based on rawdata), µg/L

$V_d$  – Digestion volume, mL

$ExpVd$  – Expected digestion volume, mL

$DF$  – Dilution factor

$ExpAmt$  – Expected amount for digestion, mL

$Aliquot$  – Amount digested, mL

10.5.3. For solids, use the following equation to calculate the concentration

$$C_s = C_i \left( \frac{ExpAmt}{Aliquot} \right) \left( \frac{V_d}{ExpVd} \right) \left( \frac{100}{100 - \%H_2O} \right) \times DF \times 0.1 \quad \text{Eq.-10.5.3}$$

where:

$C_s$  – Concentration in the sample, mg/Kg

$C_i$  – Concentration in the digestate (based on rawdata), µg/L

$V_d$  – Digestion volume, mL

$ExpVd$  – Expected digestion volume, mL

$ExpAmt$  – Expected amount for digestion, g

$Aliquot$  – Amount digested, g

## STANDARD OPERATING PROCEDURES

TRACE METALS BY ICP-MSSOP No.: EMAX-6020 Revision No. 10 Effective Date: 16-Nov-18 $\% H_2O$  – Percent moisture of the sample $DF$  – Dilution factor $0.1$  – Conversion factor10.5.4. Calculate the percent recovery (%R)

$$\% Recovery = \frac{C_f - C}{C_s} * 100 \quad \text{Eq.-10.5.4}$$

where:

 $C_f$  – Concentration found,  $\mu\text{g/L}$  $C$  – Concentration of sample,  $\mu\text{g/L}$  $C_s$  – Concentration of spike,  $\mu\text{g/L}$ 10.5.5. Relative Percent Difference (%RPD)

$$RPD = \frac{|C_1 - C_2|}{\left(\frac{C_1 + C_2}{2}\right)} \times 100 \quad \text{Eq.-10.5.5}$$

where:

 $RPD$  – Relative Percent Difference $C_1$  – Measured concentration of the first sample aliquot $C_2$  – Measured concentration of the second sample aliquot10.6. **Data Reduction**

- 10.6.1. Make a copy of the analytical run log and sample preparation log.
- 10.6.2. Highlight the data to be reported.
- 10.6.3. Print a copy of the raw data and the QC report.
- 10.6.4. Keep all other data generated with the analytical folder marked with "For record only" for traceability purpose.

10.7. **Report Generation**

- 10.7.1. Print the summary of the analytical run, perform a data transfer into a disk, and convert the instrument electronic output file into a CSV file format.
- 10.7.2. Run the ICPCHK.exe program for calibration check.
- 10.7.3. Identify samples that need to be re-analyzed, if any, and report all samples that met the analytical requirements.



## STANDARD OPERATING PROCEDURES

**TRACE METALS BY ICP-MS**SOP No.: EMAX-6020 Revision No. 10 Effective Date: 16-Nov-18

## 10.7.4. Generate the report using the following reporting program:

| Executable Files | Required Support Files   | Output   |
|------------------|--|--|
| ICPMS00.exe      | Login File (requires network)<br>Project support files (.met, .QC, .CRF, .DL, .pln, F:\ST\ProjectCode.txt)<br>ICP-MS raw data output (e.g., IF6A023.CSV)<br>Digestion log (e.g., IMA027.CSV) | [Analytical Sequence].CAL – this file summarizes ICV, ICSA and ICSAB results.<br>[Analytical Sequence].CCB – this file summarizes calibration blanks (ICB and CCBs relevant to reported SDG).<br>[Analytical Sequence].CCV – this file summarizes CCVs relevant to reported SDG.<br>Limits.CSV – this file contains target analytes and its LOQ, LOD and DL<br>SQ.CSV – this file contains the samples analyzed for the SDG being processed.<br>ARAW.CSV – this file contains the raw data of samples analyzed for the SDG being processed<br>Method.txt [this file integrates the login sample information and the analytical sample information] |
| MET1F3.exe       | Limits.CSV, SQ.CSV and ARAW.CSV  | Sample Results (Form1)<br>LCS Summary Forms (Form 3)<br>MS Summary Forms (Form 3)<br>Analytical Spike Summary Forms<br>Serial Dilution Summary Forms   |
| METF1C.exe       | Form 1   | [SampleID].TxC – Combines sample results with multiple dilutions.  |
| LABCHRNX.exe     | method.txt   | Lab Chronicle  |
| CN2.exe          | Login File, method.txt, Form 1, Form 3   | Case Narrative   |

10.8. **Data Review**

## 10.8.1. Arrange the analysis package in sequence as detailed below.

- Case Narrative

## STANDARD OPERATING PROCEDURES

TRACE METALS BY ICP-MSSOP No.: EMAX-6020 Revision No. 10 Effective Date: 16-Nov-18

- Lab Chronicle
  - Sample Results
  - LCS/LCSD Summary
  - MS/MSD Summary
  - Sample Duplicate Summary
  - Analytical Run Log
  - ICAL Summary
  - ICV Summary
  - CCV Summary
  - Sample Preparation Log
  - Non-Conformance Report (if any)
- 10.8.2. Perform a 100% data review in accordance to EMAX-DM01 and the PSR.
- Check Project Specific Requirement (PSR) or Appendix 1 for acceptance criteria.
  - Check frequency of calibration verification. Verify results to be within acceptance limits.
  - Check of target analytes concentration to be within linear range.
  - Verify interference check results to be within acceptance limits.
- 10.8.3. If any of the above checkpoints is non-compliant, re-analysis is required.
- 10.8.4. Review the attached logs that they are properly filled.
- 10.8.5. Check the generated reports against the raw data. Check that the analytical data generated indicating positive results are qualitatively and quantitatively correct.
- 10.8.6. Review the case narrative and check that it accurately describes what transpired in the analytical process. Edit as necessary to reflect essential issues not captured by the case narrative generator program.
- 10.8.7. Submit the analytical folder for secondary review.

**10.9. Preventive Maintenance**

- 10.9.1. Instruments shall receive routine preventive maintenance that is properly recorded in the instrument-specific maintenance logs. The list of maintenance is summarized in Form 6020FM. The practice ensures optimum operating condition of the equipment thus reducing the possibility of frequent instrument malfunction.

| Maintenance Activity | Description   | Frequency               |
|----------------------|---|-------------------------|
| Verification         | Verify instrument parameters to ensure normal operating conditions.<br>Change tubings as necessary.<br>Perform system tune check.<br>Check instrument performance (e.g., ICV/ICB) | Daily prior to analysis |

## STANDARD OPERATING PROCEDURES

**TRACE METALS BY ICP-MS**SOP No.: EMAX-6020 Revision No. 10 Effective Date: 16-Nov-18

| <b>Maintenance Activity</b> | <b>Description</b>   | <b>Frequency</b>               |
|-----------------------------|--|--------------------------------|
| Vacuum System Maintenance   | Inspect vacuum hoses and exhaust tubes for possible problems. Check pump for evidence of leakage | Daily prior to analysis        |
| Documentation               | Record all instrument maintenance performed in the instrument maintenance log.                   | Daily prior to analysis        |
| Ion Lens Cleaning           | Remove and clean surfaces of the ion lens. Sonicate ion lens parts                               | As necessary                   |
| System Cleaning             | Remove covers and clean dust from fans and vent covers   | Every 6 months or as necessary |
| Pump Maintenance            | Replace oil mist filter, drain and replace mechanical pump oil. Verify proper pump operation     | Every 6 months                 |
| Inspection                  | Perform general inspection of the complete system  | Once a year                    |

**11.0 QUALITY CONTROL****11.1. Sample Preparation QC**

- 11.1.1. All labwares used in the sample preparation shall be properly treated as specified in EMAX-QC07.
- 11.1.2. A preparative batch consists of 20 or fewer samples of the same matrix that are prepared for analysis simultaneously or sequentially, using the same lots of all reagents.
- 11.1.3. Every preparative batch shall have at least one method blank, one LCS and a set of MS/MSD unless otherwise specified by the project. These QC samples shall be digested together with the field samples.
- 11.1.4. All reagents shall be subjected to QC check prior to its use. Refer to EMAX-QC01 for details.

**11.2. Sample Analysis QC**

- 11.2.1. Perform a tune check before every analytical run, an initial calibration and initial calibration verification (ICV / LLICV). Obtain the ICV standard from a different source from that of the initial calibration and LLICV from the same source as the ICAL. Analyze an instrument calibration blank (ICB) after the LLICV. No further analysis shall be valid unless acceptance criteria are met.
- 11.2.2. Monitor the intensities of all internal standards for every analysis. Refer to Appendix 1 for acceptance criteria.
- 11.2.3. Verify inter-element and background correction factors with ICSA and ICSAB standards after ICB every 12 hours.
- 11.2.4. Verify calibration with continuing calibration verification (CCV) standard and continuing calibration blank (CCB) after every ten samples and at the end of the analytical run. Also verify LLCCV at the end of the analytical run.
- 11.2.5. Evaluate results of MS/MSD to document matrix interference.

## STANDARD OPERATING PROCEDURES

TRACE METALS BY ICP-MSSOP No.: EMAX-6020 Revision No. 10 Effective Date: 16-Nov-18

- 11.2.6. Perform Post Digestion Spike whenever recoveries for MS/MSD failed.
- 11.2.7. Evaluate Dilution Test result if post digestion spike result failed to meet the acceptance criteria. Failure typically happens when analyte concentrations are high.
- 11.2.8. Refer to Appendix 1 for acceptance criteria.

**11.3. Method QC**

- 11.3.1. A valid DL and LOD must exist prior to sample analysis. Refer to EMAX-QA04 for details.
- 11.3.2. Perform dynamic range study at least every six months or whenever there is a significant change in instrument response unless otherwise specified by the project.
- 11.3.3. All analysts conducting this analysis must have an established Demonstration of Capability (DOC) as described in EMAX-QA05.

**12.0 CORRECTIVE ACTION**

- 12.1. Quality control procedures and corresponding corrective actions are summarized in Appendix 1.
- 12.2. If tune is non-compliant, consider the following suggestions to correct the problem:
  - Check the instrument settings and make sure that the instrument parameters are properly set up.
  - Check argon gas flow.
  - Perform auto tune or visual optimization
  - If the problem persists, inform the Supervisor.
- 12.3. If correlation coefficient (R) of ICAL is non-compliant, consider the following suggestions to help you correct the problem:
  - Check the calibration points for possible presence of out-lier. If out-lier is present, prepare a fresh standard and repeat the calibration.
  - Check the connections and make sure that they are air-tight. Perform maintenance as needed.
    - Presence of bubbles is indicative of poor connection between the sipper and the nebulizer.
    - Poor precision to inability to light the plasma is a symptom of a poor drain tube connection
    - Poor precision and carry-over problems are indicative of a dirty spray chamber.
    - Relative increase in the sensitivity ratio of the higher: lower atomic number elements are indicative of stretched pump tubing. The sample flow rate decreases as the tubing stretches.
  - Check the argon gas flow. Loss of signal is indicative of low or no argon gas flow.
  - Poor precision and a gradual loss of signal is indicative of “salting-out” in the nebulizer and/or spray chamber due to samples with high dissolved or suspended solids. This problem will necessitate nebulizer and spray chamber cleaning.
  - If the problem persists, inform the Supervisor.
- 12.4. If ICV is non-compliant, consider the following suggestions to help you correct the problem:
  - If the RSD is high it is indicative that the carry-over might be present in the spray chamber.

## STANDARD OPERATING PROCEDURES

TRACE METALS BY ICP-MSSOP No.: EMAX-6020 Revision No. 10 Effective Date: 16-Nov-18

- 
- If result is bias high, prepare a fresh standards and repeat calibration.
  - If the problem persists, inform the Supervisor.
- 12.5. If ICB/CCB is non-compliant, consider the following suggestions to correct the problem:
- Prepare a fresh calibration blank solution. Perform instrument rinsing and repeat the ICB/CCB prior to re-analysis of associated sample(s).
  - Carry-over problem is indicative of dirty spray chamber, nebulizer and/or torch. Perform instrument maintenance and repeat the calibration.
  - If the problem persists, inform the Supervisor.
- 12.6. If CCV or LLICV or LLCCV is non-compliant, consider the following suggestions to correct the problem:
- Check the connections prior to re-running the ICAL. Refer to Section 12.3.
  - Prepare a new standard and repeat the ICAL.
- 12.7. If the intensity of the Internal Standard is non-compliant, consider the following suggestions to correct the problem:
- Check for drift occurrence by observing the internal standard intensities in the calibration blank.
  - If drift has occurred, terminate the analysis, recalibrate, verify the new calibration and reanalyze the affected samples.
  - If drift has not occurred, dilute affected samples five fold and reanalyze with the addition of appropriate amounts of internal standards.
- 12.8. If Method Blank is non-compliant, consider the following suggestions to correct the problem:
- Rule-out instrument contamination by checking the CCBs. Refer to Section 12.5.
  - Rule-out reagent contamination by testing each reagent as described in EMAX-QC01.
  - Rule-out digestate vessel contamination by adding verified reagents heating the vessels prior to testing.
    - Common environmental contaminants – Ca, Si, Fe, Na, Mg, K, Ti, Cu, Mn, can be minimized by maintaining the lab clean.
  - Other sources of contamination:
    - Sweat contains Ca, Mg, Pb, K,  $\text{NH}_4^+$ ,  $\text{SO}_4^{2-}$ ,  $\text{PO}_4^{3-}$ , and Cd (for those who smoke).
    - Cosmetics can contain high concentrations of Al, Be, Ca, Cu, Cr, K, Fe, Mn, Ti, and Zn.
    - Some hair dyes contain  $\text{Pb}(\text{OAC})_2$ .
    - Dandruff shampoo can contain significant levels of Se.
    - Eye make-up may contain Hg as a preservative.
    - Calamine lotion is almost pure ZnO.
    - Watches and jewelry contain an assortment of elements and should not be worn in the laboratory.
  - Re-digest MB and the associated samples with reagents free of contamination or with newly opened reagents.
  - If the problem persists, inform the Supervisor.

## STANDARD OPERATING PROCEDURES

**TRACE METALS BY ICP-MS**SOP No.: EMAX-6020 Revision No. 10 Effective Date: 16-Nov-18

---

12.9. If LCS is non-compliant, consider the following suggestions to correct the problem:

- If result is bias-high, check the LCS standard by analyzing at the spike level.  
If the LCS check is within 80-120 % of the expected value, check the calibration of the micropipette use for spiking. Re-digest and re-analyze the LCS and the associated samples.  
If the LCS check is not within 80-120%, prepare a fresh LCS standard, re-digest and re-analyze LCS and the associated samples.
- Common Problems with Ag, As, Ba, Pb, and Cr, indicating stock standard degradation, are as follows:  
Low Silver (Ag) recovery is indicative of Chloride contamination causing AgCl precipitation  
Low Arsenic (As) recovery is indicative of loss during sample preparation as volatile oxides (AsO<sub>3</sub>) or precipitation as AsCl<sub>3</sub>  
Low Barium (Ba) recovery is indicative of SO<sub>4</sub> or CrO<sub>4</sub> contamination. Barium will form precipitates with HF and H<sub>2</sub>SO<sub>4</sub>.  
High Lead (Pb) recovery is indicative of environmental contamination.

12.10. A Non-Conformance Report (NCR) is required when the following circumstances occur:

- Anomalies other than those specified in Appendix 1 are observed.
- Sample is out of technical holding time.

12.10.1. Refer to EMAX-QA08 for NCR details.

**13.0 POLLUTION PREVENTION**

13.1. Observe all necessary precautions to avoid spillage of solvent that may go to wastewater drains.

13.2. Prepare all standards in fume hoods.

**14.0 WASTE MANAGEMENT**

14.1. No sample may be dumped in the laboratory sink.

14.2. Separate and properly identify all unused and expired analytical standards for proper disposal.

14.3. Place all waste generated during the analytical process in properly labeled satellite waste containers for proper collection.

14.4. Dispose all unused samples, digestates, expired analytical standards and other waste generated during the analytical process in accordance to EMAX-SM03.

**15.0 SUPPLEMENTARY NOTES****15.1. Definition of Terms**

15.1.1. **Batch** – is a group of samples that are prepared and/or analyzed at the same time using the same lot of reagents.

15.1.1.1 **Preparation Batch** - is composed of one to 20 samples of the same matrix, a method blank, a lab control sample and matrix spike/matrix spike duplicate.

## STANDARD OPERATING PROCEDURES

TRACE METALS BY ICP-MSSOP No.: EMAX-6020 Revision No. 10 Effective Date: 16-Nov-18

- 15.1.1.1 **Analytical batch** - is composed of prepared samples (extracts, digestates, or concentrates), which are analyzed together as a group using an instrument in conformance to the analytical requirement. An analytical batch can include samples originating from various matrices, preparation batches, and can exceed 20 samples.
- 15.1.2. Detection Limit (DL) – The lowest concentration or amount of the target analyte that can be identified, measured and reported with confidence that the analyte concentration is not a false positive.
- 15.1.3. Limit of Detection (LOD) – An estimate of the minimum amount of substance that an analytical process can reliably detect.
- 15.1.4. Limit of Quantitation (LOQ) – The minimum levels, concentrations or quantities of target variable (e.g., target analyte) that can be reported with a specified degree of confidence.
- 15.1.5. Safety Data Sheet (SDS) – is where the physical data, toxicology and safety precaution of a certain substance is listed.
- 15.1.6. Calibration – is a determinant measured from a standard to obtain the correct value of an instrument output.
- 15.1.7. Instrument Method – is a file generated to contain the instrument calibration and instrument parameter settings for a particular analysis.
- 15.1.8. Instrument Blank – is a target-analyte-free solvent subjected to the entire analytical process to establish zero baseline or background value.
- 15.1.9. Method Blank – is a target-analyte-free sample subjected to the entire sample preparation and/or analytical procedure to monitor contamination.
- 15.1.10. Lab Control Sample (LCS) – is a target-analyte-free sample spiked with a verified known amount of target analyte(s) or a reference material with a certified known value subjected to the entire sample preparation and/or analytical process. LCS is analyzed to monitor the accuracy of the analytical system.
- 15.1.11. Lab Control Sample Duplicate (LCSD) – is a replicate of LCS analyzed to monitor precision in the absence of MS/MSD sample.
- 15.1.12. Sample – is a specimen received in the laboratory bearing a sample label traceable to the accompanying COC. Samples collected in different containers having the same field sample ID are considered the same and therefore labeled with the same lab sample ID unless otherwise specified by the project.
- 15.1.13. Sub-sample – is an aliquot taken from a sample for analysis. Each sub-sample is uniquely identified by the sample preparation ID.
- 15.1.14. Sample Duplicate – is a replicate of a sub-sample taken from one sample, prepared and analyzed within the same preparation batch.
- 15.1.15. Matrix – is a physical state of a sample. Most of environmental samples are classified as water, soil or air.
- 15.1.16. Matrix Spike (MS) – is a sample spiked with a verified known amount of target analyte(s) subjected to the entire sample preparation and/or analytical process. MS is analyzed to monitor matrix effect on a method's recovery efficiency.
- 15.1.17. Matrix Spike Duplicate (MSD) – is a replicate of MS analyzed to monitor precision or recovery.

## STANDARD OPERATING PROCEDURES

**TRACE METALS BY ICP-MS**

SOP No.: EMAX-6020 Revision No. 10 Effective Date: 16-Nov-18

---

15.1.18. Reagent Water – is purified water free from any target analyte or any other substances that may interfere with the analytical process.

15.1.19. Reagent Soil – organic-free Ottawa sand or equivalent.

**15.2. Application of EMAX QC Procedures**

15.2.1. The procedures and QC criteria summarized in this SOP shall be applied to all projects when performing metals analysis. In instances where there is a project or program QAPP, the requirements given in the project shall take precedence over this SOP.

**15.3. Department of Defense (DoD) and Department of Energy (DOE) Projects**

15.3.1. Samples from DoD and/or DOE sponsored projects follows the Quality Assurance Project Plan (QAPP), Statement of Work (SOW) and/or client's quality control directive. In the absence of QAPP, the DoD and DOE Consolidated Quality Systems Manual (QSM), latest update, is applied.

**16.0 REFERENCES**

- 16.1. "Test Methods for Evaluating Solid Waste, Physical / Chemical Methods", EPA Publication SW-846 Update IV, Method 6020A.
- 16.2. Determination of Trace Elements in Waters and Wastes by Inductively Coupled Plasma-Mass Spectrometry, Method 200.8 Rev. 5.4, 1994.
- 16.3. USEPA SW846, Method 3050B, Revision 2, December 1996.
- 16.4. Title 40 Code of Federal Regulations, Part 136 – Guidelines Establishing Test Procedures for the Analysis of Pollutants, latest edition.
- 16.5. EMAX Quality Systems Manual, as updated.

**17.0 APPENDICES**

**17.1. Tables**

- 17.1.1. Table 1 ICP-MS Elements & Isotopes
- 17.1.2. Table 2 Calibration Standard and Verification Preparation
- 17.1.3. Table 3 Calibration Standards Concentration and Reporting Limit
- 17.1.4. Table 4 ICP-MS Analytical Sequence
- 17.1.5. Table 5 DL, LOD, LOQ and Linear Range Concentration Levels

**17.2. Figures**

- 17.2.1. Figure 1 Typical Sample Report
- 17.2.2. Figure 2 Typical LCS/LCD Summary
- 17.2.3. Figure 3 Typical MS/MSD Summary
- 17.2.4. Figure 4 Typical Case Narrative



## STANDARD OPERATING PROCEDURES

TRACE METALS BY ICP-MSSOP No.: EMAX-6020 Revision No. 10 Effective Date: 16-Nov-18

---

**17.3. Appendices**

17.3.1. Appendix 1 Summary of Quality Control Procedures

17.3.2. Appendix 2 Demonstration of Capability

17.3.3. Appendix 3 Comparative Study of Modified 3050B

**17.4. Forms**

17.4.1. 6020FS Sample Preparation Log

17.4.2. 6020FA Analytical Run Log

17.4.3. 6020FM Instrument Maintenance Log

**Table 1: ICP-MS ELEMENTS & ISOTOPES**

| ELEMENT    | SYMBOL | MASS | Tune Mode | Internal Standard |
|------------|--------|------|-----------|-------------------|
| Aluminum   | Al     | 27   | 3         | Sc45              |
| Antimony   | Sb     | 121  | 3         | In115             |
| Arsenic    | As     | 75   | 2         | Ge72              |
| Barium     | Ba     | 137  | 3         | In115             |
| Beryllium  | Be     | 9    | 3         | Li6               |
| Boron      | B      | 11   | 3         | Li6               |
| Cadmium    | Cd     | 111  | 3         | In115             |
| Calcium    | Ca     | 43   | 1         | Sc45              |
| Chromium   | Cr     | 53   | 2         | Sc45              |
| Cobalt     | Co     | 59   | 3         | Sc45              |
| Copper     | Cu     | 63   | 2         | Sc45              |
| Iron       | Fe     | 57   | 1         | Sc45              |
| Lead       | Pb     | 208  | 3         | Tb159             |
| Lithium    | Li     | 7    | 3         | Li6               |
| Magnesium  | Mg     | 24   | 3         | Sc45              |
| Manganese  | Mn     | 55   | 3         | Sc45              |
| Molybdenum | Mo     | 95   | 3         | In115             |
| Nickel     | Ni     | 60   | 2         | Sc45              |
| Phosphorus | P      | 31   | 3         | Sc45              |
| Potassium  | K      | 39   | 3         | Sc45              |
| Selenium   | Se     | 78   | 1         | Ge72              |
| Silicon    | Si     | 28   | 1         | Sc 45             |
| Silver     | Ag     | 107  | 3         | In115             |
| Sodium     | Na     | 23   | 1         | Sc45              |
| Strontium  | Sr     | 88   | 3         | Y89               |
| Thallium   | Tl     | 205  | 3         | Tb159             |
| Tin        | Sn     | 118  | 3         | In115             |
| Titanium   | Ti     | 47   | 3         | Sc45              |
| Tungsten   | W      | 182  | 3         | Tb159             |
| Uranium    | U      | 238  | 3         | Tb159             |
| Vanadium   | V      | 50   | 2         | Sc45              |
| Zinc       | Zn     | 66   | 3         | Ge72              |
| Zirconium  | Zr     | 90   | 3         | Ge72              |

Tune Mode: 1=Reaction H<sub>2</sub> Mode; 2=Collision He Mode; 3= Normal Mode

**Table 2 : CALIBRATION AND VERIFICATION STANDARDS**

| Standard                  | Source   |                      | Preparation (Final Vol. (500 mL)) |                    |
|---------------------------|--|----------------------|-----------------------------------|--------------------|
|                           | Mixed Std. Name  | Concentration (mg/L) | Aliquot (mL)                      | Final Conc. (µg/L) |
| S1                        | ICAL 1, 2  | 10, 10               | 0.025, 0.025                      | 0.5                |
|                           | ICAL 3   | 1000                 | 0.025                             | 50                 |
|                           | Silicon  | 1000                 | 0.05                              | 100                |
|                           | Zn-1   | 1                    | 0.25                              | 0.5                |
|                           | W-1  | 1                    | 0.25                              | 0.5                |
|                           | Phosphorus   | 100                  | 0.125                             | 25                 |
|                           | Zr   | 100                  | 0.025                             | 5                  |
| S2                        | ICAL 4   | MIXED                | 5.0                               | MIXED              |
|                           | ICAL 5   | MIXED                | 5.0                               | MIXED              |
|                           | W  | 100                  | 0.025                             | 5                  |
|                           | Zr   | 100                  | 0.05                              | 10                 |
| S3                        | ICAL 4   | MIXED                | 25                                | MIXED              |
|                           | ICAL 5   | MIXED                | 25                                | MIXED              |
|                           | W  | 100                  | 0.125                             | 25                 |
|                           | Zr   | 100                  | 0.125                             | 25                 |
| S4                        | ICAL 4   | MIXED                | 50                                | MIXED              |
|                           | ICAL 5   | MIXED                | 50                                | MIXED              |
|                           | W  | 100                  | 250                               | 50                 |
|                           | Zr   | 100                  | 250                               | 50                 |
| ICV<br>(Individual Spike) | Fe, Al, Ca, K, Mg, Na  | 10000                | 1.5                               | 30                 |
|                           | Tl, V, Cr, Ni, Co, Cu,<br>Zn, As, Se, Sr, Mo, Cd,<br>Sn, Ba, Pb, U | 1000                 | 0.15                              | 0.3                |
|                           | Mn   | 1000                 | 1.0                               | 2                  |
|                           | Sb   | 1000                 | 0.03                              | 0.06               |
|                           | Li, Be, B, Ag, W   | 1000                 | 0.015                             | 0.03               |
|                           | Zr   | 100                  | 0.15                              | 0.03               |
|                           | P  | 1000                 | 0.15                              | 0.3                |
|                           | Si   | 1000                 | 1.5                               | 3.0                |
| CCV                       | ICAL 4   | MIXED                | 25                                | MIXED              |
|                           | ICAL 5   | MIXED                | 25                                | MIXED              |
|                           | W  | 100                  | 0.125                             | 25                 |
|                           | Zr   | 100                  | 0.125                             | 25                 |
| LLICV / LLCCV<br>(water)  | ICAL 1, 2  | 10, 10               | 0.1, 0.1                          | 0.001, 0.001       |
|                           | ICAL 3   | 1000                 | 0.1                               | 0.1                |
|                           | Zn   | 1000                 | 0.009                             | 0.01               |
|                           | B  | 1000                 | 0.009                             | 0.01               |
|                           | Sr   | 1.0                  | 1.0                               | 0.002              |
|                           | P  | 100                  | 0.5                               | 0.05               |
|                           | Zr   | 100                  | 0.05                              | 0.005              |
|                           | W  | 100                  | 0.02                              | 0.002              |
|                           | Si   | 1000                 | 0.100                             | 0.1                |
| LLICV / LLCCV<br>(soil)   | ICAL 1   | 10                   | 0.05                              | 0.0005             |
|                           | ICAL 2   | 10                   | 0.05                              | 0.0005             |
|                           | ICAL 3   | 1000                 | 0.05                              | 0.05               |
|                           | Zn   | 1.0                  | 4.0                               | 0.004              |

**Table 3: CALIBRATION STANDARDS CONCENTRATION AND REPORTING LIMIT**

| ELEMENT    | ICAL (µg/L) |      |       |       | ICV (µg/L) | CCV (µg/L) | ICSA (µg/L) | ICSAB (µg/L) |
|------------|-------------|------|-------|-------|------------|------------|-------------|--------------|
|            | S1          | S2   | S3    | S4    |            |            |             |              |
| Aluminum   | 50          | 5000 | 25000 | 50000 | 30000      | 25000      | 100000      | 100000       |
| Antimony   | 0.5         | 10   | 50    | 100   | 60         | 50         | 0           | 20           |
| Arsenic    | 0.5         | 50   | 250   | 500   | 300        | 250        | 0           | 20           |
| Barium     | 0.5         | 100  | 500   | 1000  | 300        | 500        | 0           | 20           |
| Beryllium  | 0.5         | 5    | 25    | 50    | 30         | 25         | 0           | 20           |
| Boron      | 0.5         | 10   | 50    | 100   | 30         | 50         | 0           | 20           |
| Cadmium    | 0.5         | 50   | 250   | 500   | 300        | 250        | 0           | 20           |
| Calcium    | 50          | 5000 | 25000 | 50000 | 30000      | 25000      | 100000      | 100000       |
| Chromium   | 0.5         | 50   | 250   | 500   | 300        | 250        | 0           | 20           |
| Cobalt     | 0.5         | 50   | 250   | 500   | 300        | 250        | 0           | 20           |
| Copper     | 0.5         | 50   | 250   | 500   | 300        | 250        | 0           | 20           |
| Iron       | 50          | 5000 | 25000 | 50000 | 30000      | 25000      | 100000      | 100000       |
| Lead       | 0.5         | 50   | 250   | 500   | 300        | 250        | 0           | 20           |
| Lithium    | 0.5         | 5    | 25    | 50    | 30         | 25         | 0           | 20           |
| Magnesium  | 50          | 5000 | 25000 | 50000 | 30000      | 25000      | 100000      | 100000       |
| Manganese  | 0.5         | 300  | 1500  | 3000  | 2000       | 1500       | 0           | 20           |
| Molybdenum | 0.5         | 50   | 250   | 500   | 300        | 250        | 2000        | 2000         |
| Nickel     | 0.5         | 50   | 250   | 500   | 300        | 250        | 0           | 20           |
| Phosphorus | 25          | 50   | 250   | 500   | 300        | 250        | 100000      | 100000       |
| Potassium  | 50          | 5000 | 25000 | 50000 | 30000      | 25000      | 100000      | 100000       |
| Selenium   | 0.5         | 50   | 250   | 500   | 300        | 250        | 0           | 20           |
| Silver     | 0.5         | 5    | 25    | 50    | 30         | 25         | 0           | 20           |
| Silicon    | 100         | 500  | 2500  | 5000  | 3000       | 2500       | 0           | 200          |
| Sodium     | 25          | 5000 | 25000 | 50000 | 30000      | 25000      | 100000      | 100000       |
| Strontium  | 0.5         | 50   | 250   | 500   | 300        | 250        | 0           | 20           |
| Thallium   | 0.5         | 50   | 250   | 500   | 300        | 250        | 0           | 20           |
| Tin        | 0.5         | 50   | 250   | 500   | 300        | 250        | 0           | 20           |
| Titanium   | 0.5         | 50   | 250   | 500   | 300        | 250        | 2000        | 2000         |
| Tungsten   | 0.5         | 5    | 25    | 50    | 30         | 25         | 0           | 20           |
| Uranium    | 0.5         | 50   | 250   | 500   | 300        | 250        | 0           | 20           |
| Vanadium   | 0.5         | 50   | 250   | 500   | 300        | 250        | 0           | 20           |
| Zinc       | 1           | 50   | 250   | 500   | 300        | 250        | 0           | 20           |
| Zirconium  | 5           | 10   | 25    | 50    | 30         | 25         | 0           | 20           |

**Table 4: ICP-MS ANALYTICAL SEQUENCE**

| RUN ID LABEL         | SAMPLE DESCRIPTION   | SOLUTION ID LABEL |
|----------------------|--|-------------------|
| S0                   | Calibration Standard 1 (blank)                               | S0                |
| S3, S4, S5           | ICAL Standards   | S3, S4, S5        |
| ICV                  | Initial Calibration Verification                             | ICV               |
| LLICV                | Low Level Initial Calibration Verification                   | LLICV             |
| ICB                  | Initial Calibration Blank                                    | ICB               |
| ICSA                 | Initial Interference Solution A                              | ICSA              |
| ICSAB                | Initial Interference Solution A and B                        | ICSAB             |
| CCV1                 | Continuing Calibration Verification #1                       | CCV               |
| CCB1                 | Continuing Calibration Blank #1                              | S0                |
| IMSSSSB <sup>2</sup> | Preparation Blank  |                   |
| IMSSSSL/C            | Lab Control Sample   |                   |
| Sample 1             | Sample 1   |                   |
| Sample 1M            | Sample 1 Matrix Spike  |                   |
| Sample 1S            | Sample 1 Matrix Spike Duplicate                              |                   |
| Sample 1J            | Sample 1 Serial Dilution(5x dilution sample 1)               |                   |
| Sample 1A            | Sample 1 Post Digestion spike                                |                   |
| Samples 2 to 4       | Sample 2 to Sample 5   |                   |
| CCV2                 | Continuing Calibration Verification #2                       | CCV               |
| CCB2                 | Continuing Calibration Blank #2                              | S0                |
| Samples 5 to 14      | Maximum of 10 Samples  |                   |
| CCV3                 | Continuing Calibration Verification #3                       | CCV               |
| CCB3                 | Continuing Calibration Blank #3                              | S0                |
| Samples 15 to 20     | Sample 15 to 20 or a maximum of 10 samples (sample 15 to 24) |                   |
| ICSA                 | Initial Interference Solution A                              | ICSA              |
| ICSAB                | Initial Interference Solution B                              | ICSAB             |
| CCV4                 | Continuing Calibration Verification #4                       | CCV               |
| LLCCV                | Low Level Continuing Calibration Verification                | LLCCV             |
| CCB4                 | Continuing Calibration Blank #4                              | S0                |

<sup>2</sup> where IMSSSS is the digestion batch reference.

**Table 5: DL, LOD, LOQ AND LINEAR RANGE CONCENTRATION LEVELS**

| ELEMENT    | WATER (µg/L) |     |     | SOIL (mg/kg) |      |     | LINEAR RANGE<br>µg/L |
|------------|--------------|-----|-----|--------------|------|-----|----------------------|
|            | DL           | LOD | LOQ | DL           | LOD  | LOQ |                      |
| Aluminum   | 10           | 20  | 100 | 5            | 10   | 100 | 50000                |
| Antimony   | 0.25         | 0.5 | 1   | 0.1          | 0.2  | 0.5 | 100                  |
| Arsenic    | 0.1          | 0.2 | 1   | 0.05         | 0.1  | 0.5 | 500                  |
| Barium     | 0.25         | 0.5 | 1   | 0.072        | 0.1  | 0.5 | 1000                 |
| Beryllium  | 0.05         | 0.1 | 1   | 0.05         | 0.1  | 0.5 | 50                   |
| Boron      | 2.5          | 5   | 10  | 2.5          | 5    | 10  | 100                  |
| Cadmium    | 0.1          | 0.2 | 1   | 0.057        | 0.1  | 0.5 | 500                  |
| Calcium    | 13           | 25  | 100 | 17           | 20   | 100 | 50000                |
| Chromium   | 0.1          | 0.2 | 1   | 0.05         | 0.1  | 0.5 | 500                  |
| Cobalt     | 0.1          | 0.2 | 1   | 0.05         | 0.1  | 0.5 | 500                  |
| Copper     | 0.25         | 0.5 | 1   | 0.1          | 0.2  | 0.5 | 500                  |
| Iron       | 5            | 10  | 100 | 5            | 10   | 100 | 50000                |
| Lead       | 0.05         | 0.1 | 1   | 0.05         | 0.1  | 0.5 | 500                  |
| Lithium    | 0.25         | 0.5 | 2   | 0.139        | 0.2  | 0.5 | 50                   |
| Magnesium  | 5            | 10  | 100 | 10           | 20   | 100 | 50000                |
| Manganese  | 0.1          | 0.2 | 1   | 0.153        | 0.2  | 0.5 | 3000                 |
| Molybdenum | 0.25         | 0.5 | 2   | 0.1          | 0.2  | 0.5 | 500                  |
| Nickel     | 0.1          | 0.2 | 1   | 0.063        | 0.1  | 0.5 | 500                  |
| Phosphorus | 12.5         | 25  | 50  | 12.5         | 25   | 50  | 500                  |
| Potassium  | 10           | 20  | 100 | 10           | 20   | 100 | 50000                |
| Selenium   | 0.15         | 0.3 | 1   | 0.05         | 0.1  | 0.5 | 500                  |
| Silicon    | 10           | 20  | 50  |              |      |     | 5000                 |
| Silver     | 0.1          | 0.2 | 1   | 0.05         | 0.1  | 0.5 | 50                   |
| Sodium     | 25           | 50  | 100 | 10           | 20   | 100 | 50000                |
| Strontium  | 0.5          | 1   | 2   | 0.05         | 0.1  | 0.5 | 500                  |
| Thallium   | 0.1          | 0.2 | 1   | 0.05         | 0.1  | 0.5 | 500                  |
| Tin        | 0.1          | 0.2 | 1   | 5            | 10   | 20  | 500                  |
| Titanium   | 0.25         | 0.5 | 2   | 0.125        | 0.25 | 0.5 | 500                  |
| Tungsten   | 0.5          | 1   | 2   | 0.5          | 1    | 2   | 50                   |
| Uranium    | 0.05         | 0.1 | 1   | 0.05         | 0.1  | 0.5 | 500                  |
| Vanadium   | 0.25         | 0.5 | 1   | 0.19         | 0.3  | 0.5 | 500                  |
| Zinc       | 5            | 10  | 20  | 0.683        | 1    | 2   | 500                  |
| Zirconium  | 1            | 2   | 5   | 1            | 2    | 5   | 50                   |

**Figure 1: TYPICAL SAMPLE REPORT**

METHOD SW6020A  
 METALS BY ICP-MS

```

=====
Client       : XYZ, INC.                Date Collected: MM/DD/YY HH:HH
Project      : CLEAN PROJECT           Date Received:  MM/DD/YY
SDG NO.     : YYMXXX                   Date Extracted: MM/DD/YY HH:HH
Sample ID   : ABCDEF-02                Date Analyzed:  MM/DD/YY HH:HH
Lab Samp ID : MXXX-02                  Dilution Factor: 1
Lab File ID : F6M15094                 Matrix: WATER
Ext Btch ID : IMM006W                  % Moisture: NA
Calib. Ref.: F6M15085                 Instrument ID: F6
=====
  
```

| PARAMETERS | Result<br>(ug/L) | LOQ<br>(ug/L) | DL<br>(ug/L) | LOD<br>(ug/L) |
|------------|------------------|---------------|--------------|---------------|
| Aluminum   | ND               | 100           | 10.0         | 20.0          |
| Antimony   | ND               | 1.00          | 0.250        | 0.500         |
| Arsenic    | ND               | 1.00          | 0.100        | 0.200         |
| Barium     | ND               | 1.00          | 0.250        | 0.500         |
| Beryllium  | ND               | 1.00          | 0.0500       | 0.100         |
| Cadmium    | ND               | 1.00          | 0.100        | 0.200         |
| Calcium    | 61.8J            | 100           | 13.0         | 26.0          |
| Chromium   | 0.140J           | 1.00          | 0.100        | 0.200         |
| Cobalt     | ND               | 1.00          | 0.100        | 0.200         |
| Copper     | ND               | 1.00          | 0.250        | 0.500         |
| Iron       | 5.88J            | 100           | 5.00         | 10.0          |
| Lead       | ND               | 1.00          | 0.0500       | 0.100         |
| Magnesium  | 9.54J            | 100           | 5.00         | 10.0          |
| Manganese  | 0.194J           | 1.00          | 0.100        | 0.200         |
| Nickel     | ND               | 1.00          | 0.100        | 0.200         |
| Potassium  | ND               | 100           | 10.0         | 20.0          |
| Selenium   | ND               | 1.00          | 0.150        | 0.300         |
| Silver     | ND               | 1.00          | 0.100        | 0.200         |
| Sodium     | 171              | 100           | 25.0         | 50.0          |
| Thallium   | ND               | 1.00          | 0.100        | 0.200         |
| Vanadium   | ND               | 1.00          | 0.250        | 0.500         |
| Zinc       | ND               | 20.0          | 5.00         | 10.0          |

```

=====
Note: Detection limits are reported relative to sample result significant figures.
Sample Amount   : 50ml                Final Volume:50ml
Prepared by    : MCande/LVicto       Analyzed by:SKao\LVicto
=====
  
```

Figure 2:

TYPICAL LCS/LCD SUMMARY

EMAX QUALITY CONTROL DATA  
 LAB CONTROL SAMPLE ANALYSIS

CLIENT : XYZ, INC.  
 PROJECT : CLEAN PROJECT  
 BATCH NO. : YYMXXX  
 METHOD : SW6020A

```

=====
MATRIX : WATER % MOISTURE:NA
DILUTION FACTOR: 1.00 1.00 1.00
SAMPLE ID : MBLK1W LCS1W LCD1W
LAB SAMPLE ID : IMM006WB IMM006WL IMM006WC
LAB FILE ID : F6M15087 F6M15088 F6M15089
DATE PREPARED : MM/DD/YY HH:MM MM/DD/YY HH:MM MM/DD/YY HH:MM
DATE ANALYZED : MM/DD/YY HH:MM MM/DD/YY HH:MM MM/DD/YY HH:MM
PREP BATCH : IMM006W IMM006W IMM006W
CALIBRATION REF: F6M15085 F6M15085 F6M15085
  
```

ACCESSION:

| PARAMETERS | MBResult<br>(ug/L) | SpikeAmt<br>(ug/L) | LCSResult<br>(ug/L) | LCSRec<br>(%) | SpikeAmt<br>(ug/L) | LCDResult<br>(ug/L) | LCDRec<br>(%) | RPD<br>(%) | QCLimit<br>(%) | MaxRPD<br>(%) |
|------------|--------------------|--------------------|---------------------|---------------|--------------------|---------------------|---------------|------------|----------------|---------------|
| Aluminum   | ND                 | 3000               | 3060                | 102           | 3000               | 3170                | 106           | 4          | 84-117         | 20            |
| Antimony   | ND                 | 30                 | 30.2                | 101           | 30                 | 30.3                | 101           | 0          | 85-117         | 20            |
| Arsenic    | ND                 | 30                 | 29.0                | 97            | 30                 | 28.4                | 95            | 2          | 84-116         | 20            |
| Barium     | ND                 | 30                 | 30.3                | 101           | 30                 | 30.4                | 101           | 0          | 86-114         | 20            |
| Beryllium  | ND                 | 30                 | 28.7                | 96            | 30                 | 28.1                | 94            | 2          | 83-121         | 20            |
| Cadmium    | ND                 | 30                 | 30.4                | 101           | 30                 | 30.2                | 101           | 1          | 87-115         | 20            |
| Calcium    | 75.7JE             | 3000               | 3150E               | 105           | 3000               | 3140E               | 105           | 0          | 87-118         | 20            |
| Chromium   | ND                 | 30                 | 29.6                | 99            | 30                 | 29.4                | 98            | 1          | 85-116         | 20            |
| Cobalt     | ND                 | 30                 | 30.7                | 102           | 30                 | 30.5                | 102           | 1          | 86-115         | 20            |
| Copper     | ND                 | 30                 | 29.6                | 99            | 30                 | 29.5                | 98            | 0          | 85-118         | 20            |
| Iron       | 7.20J              | 3000               | 3090                | 103           | 3000               | 3090                | 103           | 0          | 87-118         | 20            |
| Lead       | ND                 | 30                 | 33.6                | 112           | 30                 | 32.5                | 108           | 3          | 88-115         | 20            |
| Magnesium  | 6.53J              | 3000               | 3180                | 106           | 3000               | 3270                | 109           | 3          | 83-118         | 20            |
| Manganese  | 0.147J             | 30                 | 31.5                | 105           | 30                 | 30.9                | 103           | 2          | 87-115         | 20            |
| Nickel     | ND                 | 30                 | 29.3                | 98            | 30                 | 29.2                | 97            | 0          | 85-117         | 20            |
| Potassium  | ND                 | 3000               | 3150                | 105           | 3000               | 3140                | 105           | 0          | 87-115         | 20            |
| Selenium   | ND                 | 30                 | 30.4                | 101           | 30                 | 29.8                | 99            | 2          | 80-120         | 20            |
| Silver     | ND                 | 30                 | 26.9                | 90            | 30                 | 27.4                | 91            | 2          | 85-116         | 20            |
| Sodium     | 30.1J              | 3000               | 3320                | 111           | 3000               | 3300                | 110           | 1          | 85-117         | 20            |
| Thallium   | ND                 | 30                 | 33.2                | 111           | 30                 | 32.2                | 107           | 3          | 82-116         | 20            |
| Vanadium   | ND                 | 30                 | 29.0                | 97            | 30                 | 29.0                | 97            | 0          | 86-115         | 20            |
| Zinc       | ND                 | 60                 | 64.5                | 108           | 60                 | 62.2                | 104           | 4          | 83-119         | 20            |



Figure 3:

TYPICAL MS/MSD SUMMARY

EMAX QUALITY CONTROL DATA  
 MS/MSD ANALYSIS

CLIENT : XYZ, INC.  
 PROJECT : CLEAN PROJECT  
 BATCH NO. : YYMXXX  
 METHOD : SW6020A

|                                |                |                |
|--------------------------------|----------------|----------------|
| MATRIX : WATER                 |                | % MOISTURE: NA |
| DILUTION FACTOR: 1             | 1              | 1              |
| SAMPLE ID : ABCDEF-02          | ABCDEF-02MS    | ABCDEF-02MSD   |
| LAB SAMPLE ID : MXXX-02        | MXXX-02M       | MXXX-02S       |
| LAB FILE ID : F6M15094         | F6M15091       | F6M15092       |
| DATE PREPARED : MM/DD/YY HH:MM | MM/DD/YY HH:MM | MM/DD/YY HH:MM |
| DATE ANALYZED : MM/DD/YY HH:MM | MM/DD/YY HH:MM | MM/DD/YY HH:MM |
| PREP BATCH : IMM006W           | IMM006W        | IMM006W        |
| CALIBRATION REF: F6M15085      | F6M15085       | F6M15085       |

ACCESSION:

| PARAMETERS | PSResult<br>(ug/L) | SpikeAmt<br>(ug/L) | MSResult<br>(ug/L) | MSRec<br>(%) | SpikeAmt<br>(ug/L) | MSDResult<br>(ug/L) | MSDRec<br>(%) | RPD<br>(%) | QCLimit<br>(%) | MaxRPD<br>(%) |
|------------|--------------------|--------------------|--------------------|--------------|--------------------|---------------------|---------------|------------|----------------|---------------|
| Aluminum   | ND                 | 3000               | 3000               | 100          | 3000               | 3030                | 101           | 1          | 84-117         | 20            |
| Antimony   | ND                 | 30                 | 28.5               | 95.0         | 30                 | 29.9                | 99.7          | 5          | 85-117         | 20            |
| Arsenic    | ND                 | 30                 | 27.1               | 90.3         | 30                 | 28.5                | 95.0          | 5          | 84-116         | 20            |
| Barium     | ND                 | 30                 | 28.9               | 96.3         | 30                 | 30.2                | 101           | 4          | 86-114         | 20            |
| Beryllium  | ND                 | 30                 | 27.2               | 90.7         | 30                 | 28.3                | 94.3          | 4          | 83-121         | 20            |
| Cadmium    | ND                 | 30                 | 28.7               | 95.7         | 30                 | 30.1                | 100           | 5          | 87-115         | 20            |
| Calcium    | 61.8J              | 3000               | 3220               | 105          | 3000               | 3120                | 102           | 3          | 87-118         | 20            |
| Chromium   | 0.140J             | 30                 | 28.4               | 94.2         | 30                 | 29.3                | 97.2          | 3          | 85-116         | 20            |
| Cobalt     | ND                 | 30                 | 29.3               | 97.7         | 30                 | 30.2                | 101           | 3          | 86-115         | 20            |
| Copper     | ND                 | 30                 | 28.3               | 94.3         | 30                 | 29.0                | 96.7          | 2          | 85-118         | 20            |
| Iron       | 5.88J              | 3000               | 2970               | 98.8         | 3000               | 3030                | 101           | 2          | 87-118         | 20            |
| Lead       | ND                 | 30                 | 32.1               | 107          | 30                 | 32.6                | 109           | 2          | 88-115         | 20            |
| Magnesium  | 9.54J              | 3000               | 3110               | 103          | 3000               | 3150                | 105           | 1          | 83-118         | 20            |
| Manganese  | 0.194J             | 30                 | 30.2               | 100          | 30                 | 30.6                | 101           | 1          | 87-115         | 20            |
| Nickel     | ND                 | 30                 | 28.1               | 93.7         | 30                 | 28.8                | 96.0          | 2          | 85-117         | 20            |
| Potassium  | ND                 | 3000               | 3060               | 102          | 3000               | 3080                | 103           | 1          | 87-115         | 20            |
| Selenium   | ND                 | 30                 | 29.0               | 96.7         | 30                 | 29.5                | 98.3          | 2          | 80-120         | 20            |
| Silver     | ND                 | 30                 | 25.4               | 84.7*        | 30                 | 27.2                | 90.7          | 7          | 85-116         | 20            |
| Sodium     | 171                | 3000               | 3310               | 105          | 3000               | 3360                | 106           | 1          | 85-117         | 20            |
| Thallium   | ND                 | 30                 | 31.8               | 106          | 30                 | 32.5                | 108           | 2          | 82-116         | 20            |
| Vanadium   | ND                 | 30                 | 27.9               | 93.0         | 30                 | 28.6                | 95.3          | 2          | 86-115         | 20            |
| Zinc       | ND                 | 60                 | 62.8               | 105          | 60                 | 63.0                | 105           | 0          | 83-119         | 20            |

PSResult - Parent Sample Result  
 \* Out of QC limit

## Figure 4: TYPICAL CASE NARRATIVE

---

### CASE NARRATIVE

Client : XYZ, INC.

Project: CLEAN PROJECT

SDG : YYMXXX

### METHOD SW6020A METALS BY ICP-MS

A total of five (5) water samples were received on MM/DD/YY to be analyzed for Metals by ICP-MS in accordance with Method SW6020A and project specific requirements.

#### Holding Time

Samples were digested and analyzed within the prescribed holding time.

#### Calibration

Initial Calibration was established as prescribed by the method and was verified using a secondary source (ICV). Interference checks were performed and results were within required limits. Continuing calibration verifications and continuing calibration blanks were carried out at the frequency specified by the project. All calibration requirements were satisfied. MRL was analyzed as required by the project.

#### Method Blank

Method blank was prepared and analyzed at the frequency required by the project. For this SDG, one (1) method blanks were analyzed. Iron(7.20J <1/2 LOQ), Magnesium(6.53J <1/2 LOQ), Manganese(0.147J <1/2 LOQ) and Sodium(30.1J <1/2 LOQ) were detected at trace level in IMM006WB. Refer to sample result summary forms for details.

#### Lab Control Sample

Lab control sample was prepared and analyzed at a frequency required by the project. For this SDG, one (1) set of LCS/LCD was analyzed. All analytes were within LCS QC limits in IMM006WL/IMM006WC Refer to LCS summary forms for details.

#### Matrix QC Sample

Matrix spike sample was prepared and analyzed at a frequency required by the project. For this SDG, one (1) set of MS/MSD was analyzed and the following was noted: MXXX-02M/S - Percent recovery for Silver was not within QC limits in MS but was within QC limits in MSD. The rest of the analytes were in control. Analytical spike was analyzed and evaluated as appropriate. Results were within expected values. Refer to Matrix QC summary form for details.

#### Sample Analysis

Samples were analyzed according to prescribed analytical procedures. Results were evaluated in accordance to project requirements. For this SDG, all quality control requirements were met with the exception of those that were discussed within the associated QC parameter.

Appendix 1:

SUMMARY OF QUALITY CONTROL PROCEDURES

| QC PROCEDURES  | FREQUENCY   | ACCEPTANCE CRITERIA  | CORRECTIVE ACTION   | 1 <sup>st</sup> Rvw | 2 <sup>nd</sup> Rvw |
|--|---|--|---|---------------------|---------------------|
| Tune Check (Mass calibration and resolution check)       | Daily before ICAL.  | ±0.10 AMU (Mass of Isotope)<br><0.9 AMU full width resolution<br>RSD of 4 replicates : <5% | Correct problem and repeat tune check.  |                     |                     |
| Initial Calibration (multi-point)                        | Daily initial calibration prior to sample analysis.   | r ≥ 0.998  | Correct the problem and repeat the initial calibration.   |                     |                     |
| Initial Calibration Verifications (ICV)<br>Second Source | Daily after the initial calibration.  | All analytes within ±10% of expected value<br>RSD of Replicate integrations: < 5%          | Correct the problem and repeat the initial calibration.   |                     |                     |
| Low Level Calibration Verification (LLICV / LLCCV)       | LLICV: Daily after initial calibration.<br>LLCCV: At the end of the analysis sequence               | All analytes with ± 30% of expected value.   | Correct the problem and repeat the initial calibration.   |                     |                     |
| Calibration Verifications (CCV)                          | Daily before sample analysis, after every 10 samples and at the end of the analysis sequence.       | All analytes within ±10% of expected value.<br>RSD of replicate integrations < 5%.         | Repeat calibration and reanalyze all samples since last successful calibration.   |                     |                     |
| Calibration Blanks (ICB/CCB)                             | After every calibration verification  | All target analytes < ½ LOQ.   | Correct problem then reanalyze calibration blank and previous samples.  |                     |                     |
| Interference Check Sample (ICSA/ICSAB)                   | Analyze at the beginning of each analytical run or once every 12 hours, whichever is more frequent. | Within ±20% of expected value  | Terminate analysis, correct the problem, reanalyze ICS, and reanalyze all affected samples  |                     |                     |
| Internal Standard (IS)                                   | ICV, LLICV, CCV, LLCCV, CCBs, MB, LCS, every sample   | IS Intensities > 70% from Initial Calibration Blank IS Intensity                           | Correct problem then re-analyze   |                     |                     |
| Method Blank   | One per preparation batch   | All target analytes < ½ LOQ.   | Re-digest and reanalyze method blank and all samples processed with the contaminated blank.   |                     |                     |
| Laboratory Control Sample (LCS)                          | One per preparation batch   | % Recovery: 80% - 120%   | Re-digest and reanalyze LCS and all associated samples  |                     |                     |
| Matrix Spikes (MS/MSD)                                   | One MS/MSD every 20 project samples per matrix  | % Recovery: 75% - 125%<br>RPD ≤20%   | Evaluate post spike and dilution test:<br><ul style="list-style-type: none"> <li>If parent sample result is "ND", evaluate post spike.</li> <li>If parent sample result is high (i.e., 4x of spike concentration) and post spike failed, evaluate dilution test.</li> </ul> |                     |                     |
| Post Digestion Spike Addition                            | When MS fails.  | Recovery within 80-120% of expected value  | Correct the problem then reanalyze post digestion spike addition  |                     |                     |
| Dilution Test (5X)                                       | When MS fails.  | 1:5 dilution must agree within ±10% of the original determination                          | Evaluate. Discuss in case narrative.  |                     |                     |
| Instrument Detection Limit (IDL)                         | Every three months  |  | Correct the problem and repeat the IDL determination.   |                     |                     |
| Comments: Refer to PSR for flagging criteria.            |   |  |   | Reviewed By:        |                     |
|  |   |  |   | Date:               |                     |

Revision approved by: Caspar Pang, Laboratory Director (Sign/Date) 06-06-19

Kenette Pimentel, QA Manager (Sign/Date) 06/06/19

## Appendix 2: DEMONSTRATION OF CAPABILITY

MATRIX: WATER

| PARAMETER   | 18F6J16019 | 18F6J16020 | 18F6J16023 | 18F6J16024 | TV   | Ave. Conc. | Ave. %Rec | SD    | RSD (%) | Accuracy Acceptance Limits (% Rec) | RSD (%) Criteria | COMMENTS |
|-------------|------------|------------|------------|------------|------|------------|-----------|-------|---------|------------------------------------|------------------|----------|
|             | IMJ017WL   | IMJ017WC   | IMJ017WX   | IMJ017WY   |      |            |           |       |         |                                    |                  |          |
| Aluminum    | 3164       | 3137       | 3258       | 3033       | 3000 | 3148       | 105       | 92.6  | 3       | 80 - 120                           | ≤ 20             | Passed   |
| Antimony    | 31.1       | 30.1       | 32.0       | 30.1       | 30   | 30.8       | 103       | 0.890 | 3       | 80 - 120                           | ≤ 20             | Passed   |
| Arsenic     | 31.2       | 30.5       | 32.2       | 30.4       | 30   | 31.1       | 104       | 0.845 | 3       | 80 - 120                           | ≤ 20             | Passed   |
| Barium      | 31.3       | 30.5       | 32.1       | 30.3       | 30   | 31.0       | 103       | 0.812 | 3       | 80 - 120                           | ≤ 20             | Passed   |
| Beryllium   | 32.6       | 31.6       | 34.6       | 32.0       | 30   | 32.7       | 109       | 1.318 | 4       | 80 - 120                           | ≤ 20             | Passed   |
| Boron       | 32.3       | 31.8       | 34.1       | 31.5       | 30   | 32.4       | 108       | 1.166 | 4       | 80 - 120                           | ≤ 20             | Passed   |
| Cadmium     | 31.9       | 30.8       | 32.6       | 30.7       | 30   | 31.5       | 105       | 0.939 | 3       | 80 - 120                           | ≤ 20             | Passed   |
| Calcium     | 3193       | 3144       | 3353       | 3115       | 3000 | 3201       | 107       | 106.2 | 3       | 80 - 120                           | ≤ 20             | Passed   |
| Chromium    | 32.8       | 32.1       | 33.9       | 31.9       | 30   | 32.7       | 109       | 0.924 | 3       | 80 - 120                           | ≤ 20             | Passed   |
| Cobalt      | 33.1       | 33.3       | 34.6       | 32.3       | 30   | 33.3       | 111       | 0.940 | 3       | 80 - 120                           | ≤ 20             | Passed   |
| Copper      | 32.9       | 32.3       | 34.0       | 32.0       | 30   | 32.8       | 109       | 0.904 | 3       | 80 - 120                           | ≤ 20             | Passed   |
| Iron        | 3180       | 3096       | 3301       | 3075       | 3000 | 3163       | 105       | 102.6 | 3       | 80 - 120                           | ≤ 20             | Passed   |
| Lead        | 33.7       | 32.2       | 34.5       | 32.4       | 30   | 33.2       | 111       | 1.079 | 3       | 80 - 120                           | ≤ 20             | Passed   |
| Lithium     | 31.9       | 30.5       | 33.4       | 31.0       | 30   | 31.7       | 106       | 1.248 | 4       | 80 - 120                           | ≤ 20             | Passed   |
| Magnesium   | 3133       | 3104       | 3253       | 3007       | 3000 | 3124       | 104       | 101.3 | 3       | 80 - 120                           | ≤ 20             | Passed   |
| Manganese   | 33.5       | 33.6       | 35.0       | 32.6       | 30   | 33.7       | 112       | 0.981 | 3       | 80 - 120                           | ≤ 20             | Passed   |
| Molybdenum  | 30.5       | 29.3       | 30.9       | 29.1       | 30   | 29.9       | 100       | 0.899 | 3       | 80 - 120                           | ≤ 20             | Passed   |
| Nickel      | 32.9       | 32.4       | 34.2       | 32.3       | 30   | 32.9       | 110       | 0.904 | 3       | 80 - 120                           | ≤ 20             | Passed   |
| Phosphorous | 282        | 280        | 292        | 272        | 300  | 281        | 94        | 7.97  | 3       | 80 - 120                           | ≤ 20             | Passed   |
| Potassium   | 3249       | 3156       | 3305       | 3128       | 3000 | 3210       | 107       | 82.0  | 3       | 80 - 120                           | ≤ 20             | Passed   |
| Selenium    | 31.9       | 31.0       | 33.2       | 31.3       | 30   | 31.8       | 106       | 0.994 | 3       | 80 - 120                           | ≤ 20             | Passed   |
| Silicon     | 3012       | 3023       | 3161       | 3022       | 3000 | 3055       | 102       | 71.2  | 2       | 80 - 120                           | ≤ 20             | Passed   |
| Silver      | 32.2       | 31.1       | 32.6       | 31.1       | 30   | 31.7       | 106       | 0.753 | 2       | 80 - 120                           | ≤ 20             | Passed   |
| Sodium      | 3087       | 3031       | 3224       | 3002       | 3000 | 3086       | 103       | 98.5  | 3       | 80 - 120                           | ≤ 20             | Passed   |
| Strontium   | 33.3       | 31.9       | 33.6       | 32.2       | 30   | 32.8       | 109       | 0.842 | 3       | 80 - 120                           | ≤ 20             | Passed   |
| Thallium    | 33.8       | 32.3       | 34.3       | 32.5       | 30   | 33.2       | 111       | 0.956 | 3       | 80 - 120                           | ≤ 20             | Passed   |
| Tin         | 31.7       | 30.4       | 32.3       | 30.5       | 30   | 31.2       | 104       | 0.926 | 3       | 80 - 120                           | ≤ 20             | Passed   |
| Titanium    | 32.2       | 31.9       | 33.3       | 31.5       | 30   | 32.2       | 107       | 0.767 | 2       | 80 - 120                           | ≤ 20             | Passed   |
| Tungsten    | 26.4       | 25.6       | 27.2       | 25.8       | 30   | 26.2       | 87        | 0.708 | 3       | 80 - 120                           | ≤ 20             | Passed   |
| Uranium     | 32.7       | 31.4       | 33.0       | 31.5       | 30   | 32.2       | 107       | 0.829 | 3       | 80 - 120                           | ≤ 20             | Passed   |
| Vanadium    | 31.3       | 30.6       | 32.5       | 30.7       | 30   | 31.3       | 104       | 0.881 | 3       | 80 - 120                           | ≤ 20             | Passed   |
| Zinc        | 68.7       | 67.3       | 71.3       | 65.5       | 60   | 68.2       | 114       | 2.443 | 4       | 80 - 120                           | ≤ 20             | Passed   |
| Zirconium   | 29.5       | 29.1       | 30.6       | 28.7       | 30   | 29.5       | 98        | 0.830 | 3       | 80 - 120                           | ≤ 20             | Passed   |

**Appendix 2 (Cont.): DEMONSTRATION OF CAPABILITY**

MATRIX: SOIL

| PARAMETER   | 18F6J09022 | 18F6J09023 | 18F6J09024 | 18F6J09025 | TV   | Ave. Conc. | Ave. %Rec | SD    | RSD (%) | Accuracy Acceptance Limits (% Rec) | RSD (%) Criteria | COMMENTS |
|-------------|------------|------------|------------|------------|------|------------|-----------|-------|---------|------------------------------------|------------------|----------|
|             | IMJ014SL   | IMJ014SC   | IMJ014SX   | IMJ014SY   |      |            |           |       |         |                                    |                  |          |
| Aluminum    | 1924       | 1983       | 1952       | 1938       | 2000 | 1949       | 97        | 25.2  | 1       | 80 - 120                           | ≤ 20             | Passed   |
| Antimony    | 19.3       | 19.7       | 19.6       | 19.5       | 20   | 19.5       | 97        | 0.178 | 1       | 80 - 120                           | ≤ 20             | Passed   |
| Arsenic     | 19.1       | 19.7       | 19.3       | 19.1       | 20   | 19.3       | 97        | 0.308 | 2       | 80 - 120                           | ≤ 20             | Passed   |
| Barium      | 19.7       | 20.3       | 20.0       | 20.0       | 20   | 20.0       | 100       | 0.226 | 1       | 80 - 120                           | ≤ 20             | Passed   |
| Beryllium   | 20.3       | 20.9       | 20.7       | 20.3       | 20   | 20.5       | 103       | 0.268 | 1       | 80 - 120                           | ≤ 20             | Passed   |
| Boron       | 20.7       | 21.5       | 21.3       | 21.0       | 20   | 21.1       | 106       | 0.335 | 1.6     | 80 - 120                           | ≤ 20             | Passed   |
| Cadmium     | 19.8       | 20.1       | 20.0       | 20.0       | 20   | 20.0       | 100       | 0.145 | 1       | 80 - 120                           | ≤ 20             | Passed   |
| Calcium     | 2031       | 2086       | 2048       | 2053       | 2000 | 2054       | 103       | 23.0  | 1       | 80 - 120                           | ≤ 20             | Passed   |
| Chromium    | 20.2       | 20.8       | 20.3       | 21.2       | 20   | 20.6       | 103       | 0.463 | 2       | 80 - 120                           | ≤ 20             | Passed   |
| Cobalt      | 20.9       | 21.6       | 21.1       | 21.1       | 20   | 21.2       | 106       | 0.263 | 1       | 80 - 120                           | ≤ 20             | Passed   |
| Copper      | 22.0       | 22.4       | 22.0       | 21.9       | 20   | 22.1       | 110       | 0.221 | 1       | 80 - 120                           | ≤ 20             | Passed   |
| Iron        | 2032       | 2090       | 2074       | 2071       | 2000 | 2067       | 103       | 24.83 | 1       | 80 - 120                           | ≤ 20             | Passed   |
| Lead        | 20.2       | 20.8       | 20.4       | 20.2       | 20   | 20.4       | 102       | 0.284 | 1       | 80 - 120                           | ≤ 20             | Passed   |
| Lithium     | 20.4       | 21.1       | 20.6       | 20.3       | 20   | 20.6       | 103       | 0.349 | 2       | 80 - 120                           | ≤ 20             | Passed   |
| Magnesium   | 1924       | 1990       | 1940       | 1938       | 2000 | 1948       | 97        | 28.6  | 1       | 80 - 120                           | ≤ 20             | Passed   |
| Manganese   | 21.3       | 21.7       | 21.4       | 21.9       | 20   | 21.6       | 108       | 0.282 | 1       | 80 - 120                           | ≤ 20             | Passed   |
| Molybdenum  | 19.1       | 19.6       | 19.4       | 19.3       | 20   | 19.3       | 97        | 0.205 | 1       | 80 - 120                           | ≤ 20             | Passed   |
| Nickel      | 20.5       | 20.9       | 20.6       | 21.9       | 20   | 21.0       | 105       | 0.655 | 3       | 80 - 120                           | ≤ 20             | Passed   |
| Phosphorous | 202        | 209        | 206        | 207        | 200  | 206        | 103       | 2.90  | 1       | 80 - 120                           | ≤ 20             | Passed   |
| Potassium   | 2049       | 2113       | 2068       | 2096       | 2000 | 2082       | 104       | 28.5  | 1       | 80 - 120                           | ≤ 20             | Passed   |
| Selenium    | 19.3       | 20.0       | 19.5       | 19.6       | 20   | 19.6       | 98        | 0.293 | 1       | 80 - 120                           | ≤ 20             | Passed   |
| Silver      | 21.0       | 21.5       | 21.2       | 21.2       | 20   | 21.2       | 106       | 0.202 | 1       | 80 - 120                           | ≤ 20             | Passed   |
| Sodium      | 2018       | 2091       | 2069       | 2061       | 2000 | 2060       | 103       | 30.8  | 1       | 80 - 120                           | ≤ 20             | Passed   |
| Strontium   | 20.5       | 21.1       | 20.6       | 20.5       | 20   | 20.7       | 103       | 0.308 | 1       | 80 - 120                           | ≤ 20             | Passed   |
| Thallium    | 20.4       | 20.9       | 20.8       | 20.6       | 20   | 20.7       | 103       | 0.205 | 1       | 80 - 120                           | ≤ 20             | Passed   |
| Tin         | 21.8       | 22.6       | 22.2       | 22.1       | 20   | 22.2       | 111       | 0.309 | 1       | 80 - 120                           | ≤ 20             | Passed   |
| Titanium    | 20.1       | 20.6       | 20.3       | 20.3       | 20   | 20.3       | 102       | 0.179 | 1       | 80 - 120                           | ≤ 20             | Passed   |
| Tungsten    | 18.9       | 19.9       | 19.9       | 19.7       | 20   | 19.6       | 98        | 0.461 | 2.3     | 80 - 120                           | ≤ 20             | Passed   |
| Uranium     | 20.4       | 21.0       | 20.8       | 20.4       | 20   | 20.6       | 103       | 0.270 | 1       | 80 - 120                           | ≤ 20             | Passed   |
| Vanadium    | 19.7       | 20.3       | 19.8       | 19.9       | 20   | 19.9       | 100       | 0.264 | 1       | 80 - 120                           | ≤ 20             | Passed   |
| Zinc        | 40.0       | 41.8       | 40.8       | 40.5       | 40   | 41         | 102       | 0.745 | 2       | 80 - 120                           | ≤ 20             | Passed   |
| Zirconium   | 14.3       | 14.9       | 14.6       | 14.7       | 15   | 14.6       | 97        | 0.250 | 2       | 80 - 120                           | ≤ 20             | Passed   |

**Appendix 3:**

**COMPARATIVE STUDY OF MODIFIED 3050B**

ANALYTICAL METHOD: SW 6020A  
 PREPARATION BATCH: IMG031S - Modified Method 3050B  
 IMG032S - Reference Method 3050B  
 ANALYTICAL BATCH: I98H01  
 QC STANDARD: 09G281-02

Preparation Date: 7/27/2010  
 Extracted by: M. Mendoza  
 Analytical Run Date: 8/3/2010  
 Analyzed by: C. Capulong

| COMPOUND   | TRUE VALUES (mg/Kg) | ACCEPTANCE LIMITS (mg/Kg) | RECOVERY LIMITS (%) | REFERENCE METHOD 3050B |                   |                  |                   | MODIFIED METHOD 3050B |                   |                  |                   |
|------------|---------------------|---------------------------|---------------------|------------------------|-------------------|------------------|-------------------|-----------------------|-------------------|------------------|-------------------|
|            |                     |                           |                     | Concentration (mg/Kg)  |                   | Recovery         |                   | Concentration (mg/Kg) |                   | Recovery         |                   |
|            |                     |                           |                     | 98H01041 G281-02       | 98H01043 G281-02D | 98H01041 G281-02 | 98H01043 G281-02D | 98H01030 G281-02      | 98H01032 G281-02D | 98H01030 G281-02 | 98H01032 G281-02D |
| Aluminum   | 7320                | 4940 - 16400              | 67 - 224            | 10900                  | 10700             | 149%             | 146%              | 10700                 | 10700             | 146%             | 146%              |
| Antimony   | 110                 | 11.0 - 121                | 10 - 110            | 20.0                   | 19                | 18%              | 17%               | 61.4                  | 66.6              | 56%              | 61%               |
| Arsenic    | 84.2                | 42.8 - 92.7               | 51 - 110            | 61.2                   | 61.7              | 73%              | 73%               | 63.6                  | 65.3              | 76%              | 78%               |
| Barium     | 247                 | 186 - 318                 | 75 - 129            | 255                    | 260               | 103%             | 105%              | 275                   | 273               | 111%             | 111%              |
| Beryllium  | 49.0                | 29.0 - 53.9               | 59 - 110            | 39.7                   | 39.6              | 81%              | 81%               | 42                    | 41.7              | 86%              | 85%               |
| Boron      | 130                 | 61.8 - 149                | 48 - 115            | 104                    | 104               | 80%              | 80%               | 126                   | 126               | 97%              | 97%               |
| Cadmium    | 76.5                | 48.7 - 84.4               | 64 - 110            | 65.3                   | 66.7              | 85%              | 87%               | 69.9                  | 69.8              | 91%              | 91%               |
| Calcium    | 10200               | 7860 - 12900              | 77 - 126            | 9360                   | 10700             | 92%              | 105%              | 10200                 | 10300             | 100%             | 101%              |
| Chromium   | 116                 | 74.8 - 140                | 64 - 121            | 99.5                   | 98.4              | 86%              | 85%               | 107                   | 110               | 92%              | 95%               |
| Cobalt     | 64.6                | 47.2 - 79.7               | 73 - 123            | 62.1                   | 61.3              | 96%              | 95%               | 63.8                  | 64                | 99%              | 99%               |
| Copper     | 143                 | 99.7 - 166                | 70 - 116            | 116                    | 115               | 81%              | 80%               | 127                   | 126               | 89%              | 88%               |
| Iron       | 23300               | 11500 - 36200             | 49 - 155            | 23900                  | 23700             | 103%             | 102%              | 24800                 | 24800             | 106%             | 106%              |
| Lead       | 82.0                | 41.9 - 90.2               | 51 - 110            | 63.3                   | 64.9              | 77%              | 79%               | 67.5                  | 67.6              | 82%              | 82%               |
| Magnesium  | 7400                | 5300 - 9060               | 72 - 122            | 6770                   | 6760              | 91%              | 91%               | 6930                  | 7100              | 94%              | 96%               |
| Manganese  | 475                 | 428 - 724                 | 90 - 152            | 546                    | 562               | 115%             | 118%              | 584                   | 571               | 123%             | 120%              |
| Molybdenum | 66.1                | 36.0 - 72.7               | 54 - 110            | 54.9                   | 53.5              | 83%              | 81%               | 60.1                  | 59.4              | 91%              | 90%               |
| Nickel     | 144                 | 88.8 - 158                | 62 - 110            | 112                    | 113               | 78%              | 78%               | 122                   | 122               | 85%              | 85%               |
| Potassium  | 3740                | 2360 - 4990               | 63 - 133            | 3620                   | 3600              | 97%              | 96%               | 3690                  | 3560              | 99%              | 95%               |
| Selenium   | 189                 | 97.2 - 208                | 51 - 110            | 142                    | 148               | 75%              | 78%               | 154                   | 157               | 81%              | 83%               |
| Silver     | 40.6                | 21.2 - 44.6               | 52 - 110            | 30.9                   | 32.7              | 76%              | 81%               | 34.2                  | 34.9              | 84%              | 86%               |
| Sodium     | 200                 | 31.4 - 324                | 16 - 162            | 292                    | 197               | 146%             | 99%               | 192                   | 200               | 96%              | 100%              |
| Strontium  | 135                 | 88.1 - 162                | 65 - 120            | 123                    | 121               | 91%              | 90%               | 129                   | 128               | 96%              | 95%               |
| Thallium   | 127                 | 73.2 - 144                | 58 - 113            | 110                    | 114               | 87%              | 90%               | 117                   | 112               | 92%              | 88%               |
| Tin        | 250                 | 39.5 - 275                | 16 - 110            | 71.2                   | 73.2              | 28%              | 29%               | 84.7                  | 85.2              | 34%              | 34%               |
| Titanium   | 609                 | 426 - 792                 | 70 - 130            | 737                    | 744               | 121%             | 122%              | 772                   | 760               | 127%             | 125%              |
| Uranium    | 1.12                | 0.784 - 1.46              | 70 - 130            | 0.93                   | 1.1               | 83%              | 98%               | 1.03                  | 1.01              | 92%              | 90%               |
| Vanadium   | 61.8                | 55.6 - 123                | 90 - 199            | 90.2                   | 89.7              | 146%             | 145%              | 92.8                  | 93.1              | 150%             | 151%              |
| Zinc       | 208                 | 145 - 270                 | 70 - 130            | 208                    | 207               | 100%             | 100%              | 225                   | 214               | 108%             | 103%              |

\* Note: Modified 3050B procedure is specified in EMAX-3050 Rev. 4











**LABORATORIES, INC.**  
1835 W. 205th Street  
Torrance, CA 90501  
Tel: (310) 618-8889

Page 1 of 1

ADDENDUM TO

|                  |                            |
|------------------|----------------------------|
| Document         | ALL ANALYTICAL SOPS        |
| Revision Number  | CURRENT REVISIONS          |
| Section          | 10.2 Instrument Parameters |
| Date             | 11 September 2019          |
| Reference Number | AA.7                       |

This applies to all GC/MS, GC, HPLC-MS, HPLC, ICP-MS, ICP and IC Method SOPs

Section 10.2 shall include:

**10.2. Instrument Parameters**

- 10.2.1. Instrument parameters setup stipulated in the SOPs, are instrument suggested parameters. Fine tune the instrument to obtain optimum instrument condition.
- 10.2.2. Print and staple a copy of the current instrument parameter on the instrument log for easy access when performing daily instrument routine check.
- 10.2.3. In the event that instrument parameters necessitate a change, replace the instrument parameter printout with the new parameter setup. Archive the previous instrument parameters at the back of the instrument maintenance log.

PREPARED BY:  Date: 9/11/19  
Name Farina Madamba  
Title QA / QC Coordinator

APPROVED BY:  Date: 09.11.19  
Name Kenette Pimentel  
Title QA Manager

APPROVED BY:  Date: 09-11-19  
Name Caspar Pang  
Title Laboratory Director

## STANDARD OPERATING PROCEDURES

**MERCURY IN LIQUID WASTE**

SOP No.: EMAX-7470 Revision No. 8 Effective Date: 13-Jul-16  
 Prepared By: Mary Jane Mendoza *[Signature]* Date: 07.12.16  
 Approved By: Kenette Pimentel *[Signature]* Date: 07-12-16  
 QA Manager  
 Approved By: Caspar Pang *[Signature]* Date: 07-12-16  
 Laboratory Director

Control Number: 7470-08-

**1.0 SCOPE AND APPLICATION**

- 1.1. This procedure applies to the measurement of Mercury in aqueous wastes, leachates, and wastewater samples by Cold Vapor Absorption Technique.
- 1.2. This SOP is an adaptation of SW846 Methods 7470A.

**2.0 SUMMARY OF METHOD**

- 2.1. A representative amount of sample is digested in nitric and sulfuric acids, followed by oxidation with potassium permanganate and potassium persulfate.
- 2.2. Organic mercurial are broken down and converted into mercuric ions in order to respond to the cold vapor atomic absorption technique. Persulfate oxidation step, followed by addition of permanganate ensures that organo-mercury compounds are oxidized.
- 2.3. Absorption of radiation by mercury vapor at 253.7 nm is then measured in the digested samples.
- 2.4. **Interferences**
  - 2.4.1. Sulfides, as sodium sulfide, Copper and Chloride at high concentrations are known to interfere with the recovery of mercury. Samples containing such interference may require additional permanganate (about 12.5 ml).
  - 2.4.2. Care must be taken to ensure that free chlorine is absent before the mercury is swept into the cell. This may be accomplished by using an excess of hydroxylamine hydrochloride reagent.
  - 2.4.3. Certain volatile organic materials that absorb at this wavelength may also cause interference. A preliminary run without reagents should determine if this type of interference is present.

**3.0 DETECTION LIMITS**

- 3.1. **Detection Limit (DL), Limit of Detection (LOD) and Limit of Quantitation (LOQ)**
  - 3.1.1. Refer to EMAX-QA04 for generation, validation and verification of DL, LOD and LOQ.
- 3.2. **Established DL, LOD & LOQ**

| PARAMETER | DL    | LOD | LOQ  | Unit |
|-----------|-------|-----|------|------|
| Water     | 0.054 | 0.1 | 0.50 | µg/L |

## STANDARD OPERATING PROCEDURES

**MERCURY IN LIQUID WASTE**

SOP No.: EMAX-7470 Revision No. 8 Effective Date: 13-Jul-16

---

**4.0 DYNAMIC RANGE**

- 4.1. The highest quantifiable range requiring no dilution is equal to the concentration of the highest calibration point (see Section 9.6). All samples analyzed above this range are considered “over-range” and requires dilution to properly quantitate.
- 4.2. The lowest quantifiable range of diluted samples is equal to the concentration of the lowest calibration point. All diluted samples analyzed below this range are considered as “under-range” and requires lower dilution factor to properly quantitate.

**5.0 SAMPLE HOLDING TIME AND PRESERVATION****5.1. Sample Preservation**

- 5.1.1. Samples are expected to be contained in HDPE pre-cleaned containers and preserved with HNO<sub>3</sub> to pH < 2.

**5.2. Holding Time**

- 5.2.1. Samples must be analyzed within 28 days from date of collection.

**6.0 ASSOCIATED SOPs**

- 6.1. EMAX-DM01 Data Flow and Review
- 6.2. EMAX-QA04 Detection Limit (DL)
- 6.3. EMAX-QA05 Training
- 6.4. EMAX-QA08 Corrective Action
- 6.5. EMAX-QC01 Quality Control of Chemicals
- 6.6. EMAX-QC02 Analytical Standard Preparation
- 6.7. EMAX-QC06 Volumetric Labware and Micropipette Verification
- 6.8. EMAX-QC07 Glassware Cleaning
- 6.9. EMAX-SM03 Waste Disposal
- 6.10. EMAX-SM04 Analytical and QC Sample Labeling

**7.0 SAFETY**

- 7.1. Read all SDS of chemicals listed in this SOP.
- 7.2. Treat reagents, standards, and samples as potential hazards. Observe the standard laboratory safety procedures. Wear protective gear, i.e., lab coat, safety glasses, and gloves at all times when performing this procedure. Perform preparation and analysis of mercury in a fume hood equipped with an exhaust fan or blower.

## STANDARD OPERATING PROCEDURES

**MERCURY IN LIQUID WASTE**

SOP No.: EMAX-7470 Revision No. 8 Effective Date: 13-Jul-16

---

- 7.3. If for any reason, sample and/or other reagents get in contact with your skin or any other part of your body, rinse the affected body part thoroughly with copious amounts of water. If irritations persist inform your supervisor immediately so that proper action can be taken.
- 7.4. Do not look directly at the Mercury Lamp while lit. The radiation may cause damage to your eyes.
- 7.5. Perform all reagent additions under a fume hood.
- 7.6. Mercury Analyzers are to be used by trained personnel only.

**8.0 INSTRUMENTS, CHEMICALS AND REAGENTS****8.1. Instruments and Supplies**

## 8.1.1. Mercury Analyzers

8.1.1.1. Leeman PS-200 Automated Mercury Analyzer with Autosampler, Computer, Printer and PS 200 Software, Win Hg Runner 1.3

8.1.1.2. Leeman Hydra AA Automated Analyzer with Autosampler, Computer, Printer and PS200 Software, Win Hg Runner 1.3

8.1.2. 100 ml Digestion vessel

8.1.3. Digestion block or equivalent

8.1.4. Micropipettes and tips

8.1.5. Thermometer

**8.2. Chemicals and Reagents**

8.2.1. Where available, purchase reagent grade chemicals and reagents

8.2.2. Sulfuric Acid, concentrated

8.2.3. Nitric Acid, concentrated

8.2.4. Sodium chloride - hydroxylamine hydrochloride solution: Dissolve 120 g of sodium chloride and 120 g of hydroxylamine hydrochloride in reagent water and dilute to 1 L. (*Note: Hydroxylamine sulfate may be used in place of hydroxylamine hydrochloride.*)

8.2.5. Potassium Permanganate, 5% solution: Dissolve 50 g of potassium permanganate in 1 L reagent water.

8.2.6. Potassium Persulfate, 5% solution: Dissolve 50 g of potassium persulfate in 1 L reagent water.

8.2.7. Stannous Chloride – 10% solution: Dissolve 200 g of SnCl<sub>2</sub> in reagent water, add 200 ml HCl and volume to 2 L.

8.2.8. Reagent water – Mercury-free water

**9.0 STANDARDS**

9.1. Refer to EMAX-QC02 for proper analytical standard preparations.

9.2. Other concentration levels may be prepared to meet the data quality objective of a project.

## STANDARD OPERATING PROCEDURES

**MERCURY IN LIQUID WASTE**SOP No.: EMAX-7470 Revision No. 8 Effective Date: 13-Jul-16**9.3. Stock Standard**

- 9.3.1. Purchase stock standards as certified solutions from two different vendors. Use one as primary standard and the other as secondary standard.

| Stock Std | Name    | Source                     | Conc.     | Used for   |
|-----------|---------|----------------------------|-----------|------------|
| Primary   | Mercury | ERA or equivalent          | 1000 mg/L | ICAL, CCV  |
| Secondary | Mercury | AccuStandard or equivalent | 1000 mg/L | ICV/LCS/MS |

- 9.3.2. Transfer standards on a properly labeled inert vial with minimal headspace and store it at -10°C to -20°C.

**9.4. Intermediate Standard Solution**

- 9.4.1. Primary Intermediate Standard, 10.0 mg/L: Dilute 1.0 mL of 1000 mg/L Hg primary stock standard to 100 mL using reagent water. Transfer the standard in a clean and properly labeled container.
- 9.4.2. Secondary Intermediate Standard, 10.0 mg/L: Dilute 1.0 mL of 1000 mg/L Hg secondary stock standard to 100 mL using reagent water. Transfer the standard in a clean and properly labeled container.
- 9.4.3. Post Spike Standard, 100 µg/L: Dilute 1.0 mL of 10 mg/L Hg primary intermediate standard to 100 mL using reagent water. Digest prior to use.

**9.5. Working Standard**

- 9.5.1. Primary Working Standard, 50 µg/L: Dilute 0.50 mL of 10 mg/L primary intermediate standard to 100 mL using reagent water. Transfer the standard in a clean and properly labeled container.
- 9.5.2. Secondary Working Standard, 50 µg/L: Dilute 0.50 mL of 10 mg/L secondary intermediate standard to 100 mL using reagent water. Transfer the standard in a clean and properly labeled container.

**9.6. Initial Calibration Standards**

- 9.6.1. Initial calibration consists of five standards and a reagent water blank. Using the primary working standard, prepare the ICAL points in reagent water, as follows:

| Level | Primary Working Standard, 100 µg/L Aliquot (ml) | Final Volume (mL) | Concentration (µg/L) |
|-------|---|-------------------|----------------------|
| S0    | 0   | 50                | 0                    |
| S1    | 0.2   | 50                | 0.2                  |
| S2    | 0.5   | 50                | 0.5                  |
| S3    | 1.0   | 50                | 1.0                  |
| S4    | 2.0   | 50                | 2.0                  |
| S5    | 5.0   | 50                | 5.0                  |

**Note: Other concentration levels may be prepared as appropriate to meet project quality objectives.**

**9.7. Initial Calibration Verification Standard (ICV)**

## STANDARD OPERATING PROCEDURES

**MERCURY IN LIQUID WASTE**

SOP No.: EMAX-7470 Revision No. 8 Effective Date: 13-Jul-16

9.7.1. Prepare ICV at 2 µg/L by diluting 2mL of secondary working standard (50 µg/L) to final volume of 50 mL using reagent water

9.8. **Continuing Calibration Verification Standard (CCV)**

9.8.1. Prepare CCV at 2 µg/L by diluting 2 mL of primary working standard (50 µg/L) to final volume of 50 mL using reagent water.

9.9. **Laboratory Control Standard (LCS) / Matrix Spike (MS) Standard**

9.9.1. Spike 2.5mL of secondary working standard (50 µg/L) to 50 mL reagent water (for LCS) or designated sample (for MS).

**10.0 PROCEDURES**

10.1. **Sample Preparation**

10.1.1. Transfer 50 mL of sample into 100 ml digestion vessel. Use reagent water for method blank, LCS, and calibration standards. For STLC and TCLP extracts, use 5 ml sample volume diluted with reagent water to 50 ml. (The reduction of the volume is due to waste minimization.)

10.1.2. Prepare LCS/MS (Sec. 9.9.1). Spike appropriate standards for ICAL standards (Sec. 9.6.1), ICV (Sec. 9.7.1) and CCV (Sec. 9.8.1).

10.1.2.1. **Spike Addition.** Call a witness. Have the witness verify the setting of the micropipette and the expiration date of the spike standard.

10.1.3. Add 2.5 mL of concentrated H<sub>2</sub>SO<sub>4</sub> and 1.25 mL concentrated HNO<sub>3</sub> with mixing after each addition.

10.1.4. Add 7.5 mL of 5% KMnO<sub>4</sub> solution to each vessel.

10.1.5. Swirl each vessel to mix and let it stand by for 15 min. Check each vessel if purple color persist. If not, add permanganate solution at 2.5 mL increments (maximum total amount of 12.5 mL) swirling the Digestion vessel at every addition, until purple color persists.

*Add the same amount of permanganate solution added to a sample, to the method blank, LCS, calibration standards and calibration verification standards.*

10.1.6. Add 4 mL of 5% potassium persulfate. Heat for 2 hours in hot block maintained at 95 ± 3°C.

10.1.7. Allow the samples to cool.

10.1.8. Add 3 mL NaCl-hydroxylamine hydrochloride solution and wait for the sample to decolorize. Additional NaCl-hydroxylamine hydrochloride solution may be added to reduce excess permanganate in 1 mL increments up to a maximum total amount of 5 mL.

*Add the same amount of NaCl-hydroxylamine hypochloride solution added to the method blank, LCS, calibration standards and calibration verification standards.*

10.1.9. Upon decolorization, dilute to 80 mL final volume using reagent water.

10.1.10. Properly fill up the sample preparation log.

10.2. **Instrument Parameters**

10.2.1. PROTOCOL

## STANDARD OPERATING PROCEDURES

**MERCURY IN LIQUID WASTE**SOP No.: EMAX-7470 Revision No. 8 Effective Date: 13-Jul-16

## 10.2.1.1. Set Values

|                       |                      |                      |
|-----------------------|----------------------|----------------------|
| Instrument ID:        | PS200                | HYDRA AA             |
| Number of Integration | 1                    |                      |
| Uptake time           | 20 sec.              | 18 sec.              |
| Weight                | N                    | N                    |
| Dilution              | N                    | N                    |
| On/Off, times, gains  |                      |                      |
| On                    | Y                    | Y                    |
| Time                  | 10                   | 10                   |
| Gas                   | 0.35 LPM             | 0.15 LPM             |
| Pump Rate             | 5 ml/min             | 7 ml/min             |
| AUTOSAMPLER – Setup   |                      |                      |
| Station 1 (rack1)     | From cup 1 to cup 44 | From cup 1 to cup 44 |
| Station 2 (rack 2)    | From cup 1 to cup 44 | From cup 1 to cup 44 |
| Rinse time            | 50 sec.              | 60 sec.              |

|                        |                              |                              |
|------------------------|------------------------------|------------------------------|
| CALIBRATION            | Concentration, µg/L          | Concentration, µg/L          |
| S0, S1, S2, S3, S4, S5 | 0 0,,20, 0.50, 1.0, 2.0, 5.0 | 0 0,,20, 0.50, 1.0, 2.0, 5.0 |

## 10.2.2. DATA OUTPUT – Specify Report

| Data Output   | Real Time | Post Run |
|---|-----------|----------|
| Samples   | Y         | Y        |
| Standards   | Y         | Y        |
| Updates   | Y         | Y        |
| Peaks   | N         | N        |
| IEC Stds.   | N         | N        |
| Check Stds.   | Y         | Y        |
| Dups and % Diff.                                    | Y         | Y        |
| Wavelength  | N         | N        |
| Rel. Absorbances                                    | N         | N        |
| % RSD   | Y         | Y        |
| Scans to PRN  |           | N        |
| Detail  |           | Y        |
| Summary   |           | N        |
| Post Run Copies                                     |           | 1        |
| Post Run Report Order<br>[ 1-sorted; 2- sequential] | 2         |          |



## STANDARD OPERATING PROCEDURES

**MERCURY IN LIQUID WASTE**

SOP No.: EMAX-7470 Revision No. 8 Effective Date: 13-Jul-16

---

**10.3. Calibration****10.3.1. Instrument Set-up**

10.3.1.1. Set up PS200 or Hydra AA to proper operating parameters. Refer to Sec. 10.2.1.

*New pump tubing, must be ran with rinse for 45 minutes to break in the tubing.*

10.3.1.2. Turn on the lamp and allow to warm up for at least 5 minutes.

10.3.1.3. Check the peristaltic pump to deliver a steady flow.

10.3.1.4. Check that the reductant solution, 10% SnCl<sub>2</sub>, is sufficient. If not, prepare solution as described in Section 8.2.7.

**10.3.2. Initial Calibration (ICAL)**

10.3.2.1. Prepare initial calibration solution as described in Sec. 9.6.1.

10.3.2.2. Digest the ICAL standards as described in Sec. 10.1.

10.3.2.3. Analyze them as described in Sec. 10.4.

10.3.2.4. Refer to Sec. 10.5 for calculation.

10.3.2.5. Initiate initial calibration as described in the instrument operations manual. After calibration is completed, acquire the calibration data and review.

10.3.2.6. Refer to Appendix 1 for acceptance criteria.

10.3.2.7. Verify the initial calibration by a secondary source standard (ICV).

**10.3.3. Initial Calibration Verification (ICV)**

10.3.3.1. Prepare ICV as described in Sec. 9.7.1. Prepare ICB using reagent water.

10.3.3.2. Digest ICV and ICB as described in Sec. 10.1.

10.3.3.3. Analyze the ICV sample to verify the concentration of the ICAL. Analyze the ICB after the ICV.

10.3.3.4. Refer to Appendix 1 for acceptance criteria.

**10.3.4. Continuing Calibration Verification (CCV)**

10.3.4.1. Prepare CCV as described in Sec. 9.8.1. Prepare CCB using reagent water.

10.3.4.2. Digest the CCV and CCB as described in Sec. 10.1.

10.3.4.3. Analyze CCV sample to verify the validity of ICAL. Analyze the CCB after the CCV.

10.3.4.4. Refer to Appendix 1 for acceptance criteria.

**10.4. Analysis****10.4.1. Calibration**

10.4.1.1. Refer to the instrument operations manual for proper calibration and analytical sequence setup (autosampler setup).

10.4.1.2. Analytical batch ID naming convention: MIIMSSS

where:

## STANDARD OPERATING PROCEDURES

**MERCURY IN LIQUID WASTE**SOP No.: EMAX-7470 Revision No. 8 Effective Date: 13-Jul-16

“M” – is for Mercury and is always the first character

II – is the instrument number

M – is the month code (A for January, B for February, and so on)

SSS – is a sequential number (resets to 001 for the first folder created each month)

**10.4.1.3. Typical Calibration Sequence**

|    |         |
|----|---------|
| S0 | 0.00000 |
| S1 | 0.20000 |
| S2 | 0.50000 |
| S3 | 1.00000 |
| S4 | 2.00000 |
| S5 | 5.00000 |
| S6 | 10.0000 |

**10.4.2. Analytical Sequence**

10.4.2.1. ICV

10.4.2.2. ICB

10.4.2.3. CCV1

10.4.2.4. CCB1

10.4.2.5. Method Blank (MB)

10.4.2.6. Lab Control Sample (LCS)

10.4.2.7. Lab Control Sample Duplicate (LCSD)

10.4.2.8. Post Digestion Spike (Sec. 10.4.4)

10.4.2.9. Parent Sample

10.4.2.10. Serial Dilution (Sec. 10.4.5)

10.4.2.11. Matrix Spike (MS)

10.4.2.12. Matrix Spike Duplicate (MSD)

10.4.2.13. Maximum of 2 samples

10.4.2.14. CCV2

10.4.2.15. CCB2

10.4.2.16. Maximum of 10 samples

10.4.2.17. CCV3

10.4.2.18. CCB3

10.4.3. Using the analytical sequence, arrange the digested standards and samples to be analyzed chronologically.

## STANDARD OPERATING PROCEDURES

**MERCURY IN LIQUID WASTE**

SOP No.: EMAX-7470 Revision No. 8 Effective Date: 13-Jul-16

---

- 10.4.4. Transfer about 6 ml of the digestates into the autosampler tubes placing them on the autosampler rack in the same order as the analytical sequence.
- 10.4.5. Prepare a Dilution Test sample at 5x dilution. Pipette 2 mL of sample, add 8 mL of S0 into a sample tube. Seal the tube with parafilm and invert the tube several times to ensure adequate mixing.
- 10.4.6. Prepare a Post Digestion Spike test sample. Using 10 mL unspiked sample digestate (preferably the QC sample), add 0.3 mL Post Spike standard (Sec. 9.4.3).
- 10.4.7. Set the prepared samples into the autosampler and start the analytical run.
- 10.4.8. Sample Result Evaluation
- 10.4.8.1. Check the QC data as soon as available.
- ✓ Check the ICAL and ICV prior to sample analysis.
  - ✓ Check the method blank and LCS against project specific requirements.
  - ✓ Check the matrix QC sample that it meets the acceptance criteria or note possible matrix interference in the run log.
  - ✓ Check that all samples are analyzed within the calibration range. Dilute the samples that measured over the absorbance of the highest calibration point.
  - ✓ Check that the analytical data generated indicating positive results are qualitatively and quantitatively correct.
  - ✓ Check the calibration checks to make sure that the instrument is functioning properly.
- 10.4.8.2. Refer to Sec. 11 for quality control and Sec. 12 for corrective action.
- 10.4.8.3. Refer to Appendix 1 for acceptance criteria. If any of the acceptance criteria is not met, perform the necessary corrective action. If problem persists, inform the Supervisor for further action.
- 10.4.8.4. Properly fill up the analytical run log.
- 10.4.8.5. Upload the electronic data to the network.
- 10.4.9. Dealing with Carryover
- 10.4.9.1. Check the sample analyzed preceded by another sample found to have target analyte concentrations exceeding the calibration range.
- 10.4.9.2. If the target analyte is not detected, as found in the preceding high concentration sample, proceed with data reduction.
- 10.4.9.3. If the target analyte is detected, as found in the preceding high concentration sample, re-analyze the sample to rule-out carryover. If carryover is confirmed, proceed with data reduction and report the data from re-analysis.
- 10.4.10. Method of Standard Addition (MSA)
- 10.4.10.1. Perform MSA for all EP extracts, samples for de-listing petition, whenever a new matrix is encountered and/or as indicated above.

## STANDARD OPERATING PROCEDURES

**MERCURY IN LIQUID WASTE**SOP No.: EMAX-7470 Revision No. 8 Effective Date: 13-Jul-16

10.4.10.2. Prepare three sample solutions (Ms1, Ms2, Ms3) to objectively produce equal increments of concentration in the final solution without diluting the sample more than 50% of its original volume and expected concentrations falls within the linear range.

*Example: Sample concentration is tentatively determined at 2 µg/L.*

*Ms1 – take 10 ml of digestate and add 0.2 ml of 100 µg/L spike standard (≈ 6 µg/L)*

*Ms2 – take 10 ml of digestate and add 0.4 ml of 100 µg/L spike standard (≈ 7 µg/L)*

*Ms3 – take 10 ml of digestate and add 0.6 ml of 100 µg/L spike standard (≈ 8 µg/L)*

10.4.10.3. Analyze Ms1, Ms2 and Ms3 and calculate the results using Eq.-10.5.5.

**10.5. Calculations****10.5.1. Calibration Factor**

Plot the absorbance (y-axis) versus the known concentration of the calibration standards (x-axis) using Excel spreadsheet or equivalent. The reciprocal of the slope shall be the calibration factor.

**10.5.2. Calculate for Mercury Concentration**

$$C = [(A + CF) - Y] * DF \quad \text{Eq.-10.5.2}$$

where:

- $C$  – Concentration of Mercury, µg/L
- $A$  – Absorbance
- $CF$  – Calibration Factor = 1/slope
- $Y$  – Y-intercept / slope
- $DF$  – Dilution Factor

**10.5.3. Calculate for Percent Recovery**

$$\% \text{ Recovery} = \frac{(C_f - C)}{C_s} \times 100 \quad \text{Eq.-10.5.3}$$

where:

- $C_f$  – Concentration found
- $C$  – Concentration of the sample (use 0 for LCS)
- $C_s$  – Concentration of spike

**10.5.4. Calculate for Relative Percent Difference**

$$RPD = \frac{|C_1 - C_2|}{\left(\frac{C_1 + C_2}{2}\right)} \times 100 \quad \text{Eq.-10.5.4}$$

where:

- $RPD$  – Relative Percent Difference
- $C_1$  – Measured concentration of the first sample aliquot
- $C_2$  – Measured concentration of the second sample aliquot

## STANDARD OPERATING PROCEDURES

**MERCURY IN LIQUID WASTE**

SOP No.: EMAX-7470 Revision No. 8 Effective Date: 13-Jul-16

---

10.5.5. Calculation for MSA

$$C_x = \frac{(S_2)(V_s)(C_s)}{(S_2 - S_1)V_x} \quad \text{Eq.-10.5.5}$$

where:

- $C_x$  – Concentration of the sample
- $C_s$  – Concentration of spike
- $S_1$  – Analytical signal of MS1
- $S_2$  – Analytical signal of MS2
- $V_x$  – Volume of sample aliquot
- $V_s$  – Volume of spike or reagent water

10.6. **Data Reduction**

- 10.6.1. Make a copy of the analytical run and sample preparation log.
- 10.6.2. Print a copy of raw data and the QC report.
- 10.6.3. Highlight the data to be reported.
- 10.6.4. Collate the reportable data separating the QC results from the sample results.
- 10.6.5. Keep all other data generated with the analytical folder marked with “For record only”.

10.7. **Report Generation**

- 10.7.1. Generate the method.txt file and sample results using HGF1.exe.
- 10.7.2. Generate the QC summaries using HGF3.exe.
- 10.7.3. Generate the case narrative using CN00.exe.
- 10.7.4. Arrange the analysis package in sequence as detailed below.
  - 10.7.4.1. Case Narrative
  - 10.7.4.2. Lab Chronicle
  - 10.7.4.3. Sample Results
  - 10.7.4.4. LCS/LCSD Summary
  - 10.7.4.5. MS/MSD Summary
  - 10.7.4.6. Post Digestion Spike Summary
  - 10.7.4.7. Dilution Test Result Summary
  - 10.7.4.8. Analytical Run Log
  - 10.7.4.9. Raw Data
  - 10.7.4.10. Sample Preparation Log
  - 10.7.4.11. Non-Conformance Report (if any)

10.8. **Data Review**

## STANDARD OPERATING PROCEDURES

**MERCURY IN LIQUID WASTE**

SOP No.: EMAX-7470 Revision No. 8 Effective Date: 13-Jul-16

---

10.8.1. Perform a 100% data review in accordance to EMAX-DM01 and the PSR.

- ✓ Check method blank is compliant to Project Specific Requirements (PSR) criteria.
- ✓ Check LCS/LCSD, MS/MSD and Dilution test against QC limits.
- ✓ Check analytical spike test if dilution test failed.
- ✓ Check for possible carry-over and if confirmation is performed.
- ✓ Review the attached logs that they are properly filled.
- ✓ Check the generated reports against the raw data, analytical run log and sample preparation log. Check that the analytical data generated indicating positive results are qualitatively and quantitatively correct.
- ✓ Review the case narrative and check that it accurately describes what transpired in the analytical process. Edit as necessary to reflect essential issues not captured by the case narrative generator program.

10.8.2. Submit the analytical folder for secondary review

10.9. **Preventive Maintenance**

10.9.1. Daily routine maintenance must be observed religiously. Observe manufacturer's notes regarding DOs and DON'Ts:

- System preparation is a **MUST** before instrument startup.
- Make certain that drying tube has been packed loosely. If drying tube is blocked, liquid may backflow into the optical cell; this will require disassembly and leaning.
- Do not shutdown the instrument when operational, abort the run first if interruption is needed.

10.9.2. Daily routine maintenance including checking of reductant solution, 10% SnCl<sub>2</sub>, troubleshooting and major repairs must be recorded in the maintenance log. Refer to Form 7470FM.

10.9.3. Maintain the instrument clean at all times.

10.9.4. For troubleshooting, consult the Operations Manual, Section 4.

11.0 **QUALITY CONTROL**

11.1. **Sample Preparation QC**

11.1.1. Pipettes must be calibrated prior to its use. Refer to EMAX-QC06.

11.1.2. Reagents are subjected to QC check prior to its use. Refer to EMAX-QC01.

11.1.3. Properly treat all lab wares used in the sample preparations as specified in EMAX-QC07.

11.1.4. A preparative batch consists of 20 or fewer samples of the same matrix, that are prepared for analysis simultaneously or sequentially, using the same lots of all reagents.

11.1.5. Every preparative batch must have at least one method blank, one LCS and a set of MS/MSD unless otherwise specified by the project. Digest QC samples together with the field samples.

11.2. **Sample Analysis QC**

## STANDARD OPERATING PROCEDURES

**MERCURY IN LIQUID WASTE**

SOP No.: EMAX-7470 Revision No. 8 Effective Date: 13-Jul-16

---

- 11.2.1. Every analytical run is preceded by an Initial Calibration (ICAL) and Initial Calibration Verification. The ICV standard should be obtained from a different source from that of the initial calibration. Analyze an instrument calibration blank (ICB) after the ICV. No further analysis is valid unless acceptance criteria are met.
- 11.2.2. Verify calibration with Continuing Calibration Verification (CCV) standard and Continuing Calibration Blank (CCB) after every ten samples and at the end of the analytical run.
- 11.2.3. Evaluate MS/MSD to document matrix interference.
- 11.2.4. Dilution Test shall be performed whenever a new or unusual sample matrix is encountered.
- 11.2.5. Perform Post Digestion Spike result if the recoveries of MS/MSD fail and if dilution test failed.
- 11.2.6. Use Method of Standard Addition (MSA) technique for analysis of all EP extracts and whenever a new sample matrix is being analyzed.
- 11.2.7. Refer to Appendix 1 for acceptance criteria.

**11.3. Method QC**

- 11.3.1. Detection Limit study must be established before the analytical procedure can be used. Quarterly verification must be performed. Refer to EMAX-QA04.
- 11.3.2. All analysts conducting this analysis must have an established Demonstration of Capability (DOC) as described in EMAX-QA05.

**12.0 CORRECTIVE ACTION**

12.1. Corrective actions for each Quality Control Procedure is summarized in Appendix 1.

**12.2. Calibration**

- 12.2.1. Initial Calibration (ICAL) - if ICAL is non-compliant, consider the following suggestions to correct the problem:
  - Replace the sample tubing, prepare fresh rinsate and re-prepare fresh SnCl<sub>2</sub>. Rinse the system for at least 15 minutes prior to calibration.
  - If problem persist, run the latest calibration standard that passed to check for possible instrumentation problem. If it passes, this is an indication that no instrumentation problem exist, re-digest the calibration standards. If it failed, clean the lamp, prior to re-calibration.
  - If problem persist, inform the supervisor for further action
- 12.2.2. Initial Calibration Verification (ICV) - if the ICV is non-compliant, consider the following suggestions to correct the problem:
  - Run the latest ICV standard that passed to check for possible standards preparation error. If it passes, this is an indication of standards preparation error. Re-digest the ICV and re-analyze. If it fails, refer to Sec. 12.1.1 prior to re-calibration.
- 12.2.3. Continuing Calibration Verification (CCV) - If CCV is non-compliant, consider the following suggestion to correct the problem:

## STANDARD OPERATING PROCEDURES

**MERCURY IN LIQUID WASTE**

SOP No.: EMAX-7470 Revision No. 8 Effective Date: 13-Jul-16

---

- Run the latest CCV standard that passed to check for possible standards preparation error. If it passes, this is an indication of standards preparation error. Re-digest the CCV and re-analyze. If it fails, refer to Sec. 12.1.1 prior to re-calibration.

**12.3. Sample Prep QC**

12.3.1. For insufficient amount of sample(s), inform the supervisor immediately for further action.

12.3.2. Method Blank (MB) - if MB is non-compliant, consider the following suggestion to correct the problem:

- Check the sample results. If sample results are non-detected, you may report the result upon concurring with the PM, otherwise perform the corrective action as specified in the PSR.

**12.4. Sample Analysis QC**

12.4.1. Lab Control Sample (LCS) - If LCS is non-compliant, consider the following suggestions to correct the problem:

- Check for errors in calculation and concentration of the analyte solution.
- Check instrument performance to determine if it is within acceptable guidelines.
- Re-calculate the data and/or re-analyze the extract if any of the above checks reveals a problem.
- If re-analysis results are the same as the initial result, consult the Supervisor for further action. If results indicate digestion problem, fill-up an NCR and order re-digestion to include the associated sample(s).

12.4.2. Matrix Spike / Matrix Spike Duplicate (MS/MSD) - If MS is non-compliant, consider the following suggestions to correct the problem:

- If recovery failed to meet the acceptance criteria and sample result is > 5X the LOQ and the spike amount is > 4X the parent sample concentration, evaluate the post digestion spike sample result. Refer to Appendix 1 for acceptance criteria. If it fails to meet the acceptance criteria, perform MSA.
- If recovery failed to meet the acceptance criteria and sample result is ~ 5X the LOQ and the spike amount is > 4X of the parent sample concentration, evaluate the serial dilution sample result. Refer to Appendix 1 for acceptance criteria. If it fails to meet the acceptance criteria, perform MSA.

12.5. A Non-Conformance Report (NCR) is required when the following circumstances occur:

- Anomalies other than specified in Appendix 1 is observed.
- Sample is out of technical holding time.

12.5.1. Refer to EMAX-QA08.

**13.0 POLLUTION PREVENTION**

13.1. Mercury is a very volatile element, dangerous levels are readily attained in air. Mercury vapour should not exceed 0.1 mg/m<sup>-3</sup> in air. Air saturated with the vapor at 20°C contains mercury in a concentration far greater than that limit. The danger increases at higher temperatures. It is therefore important that



## STANDARD OPERATING PROCEDURES

**MERCURY IN LIQUID WASTE**

SOP No.: EMAX-7470 Revision No. 8 Effective Date: 13-Jul-16

---

mercury be handled with care. Containers of mercury must be securely covered and spillage must be avoided. Mercury must only be handled under in a well-ventilated area. Prepare all standards in the fume hoods.

- 13.2. Because of the toxic nature of mercury vapor, precaution must be taken to avoid its inhalation. A bypass must be included on the system to vent the mercury vapor into an exhaust hood.
- 13.3. Small amounts of mercury spillage can be cleaned up by addition of sulphur powder. The resulting mixture must be properly labeled and turned over to the waste disposal unit for proper disposal.
- 13.4. Observe all necessary precautions to avoid spillage of solvent that may go to wastewater drains.
- 13.5. To prevent internal pollution, the entire sample preparation process and analytical standard preparation must be conducted in a properly functioning fume hood.

**14.0 WASTE MANAGEMENT**

- 14.1. No samples may be dumped on the laboratory sink.
- 14.2. Separate and properly identify all unused and expired analytical standards for proper disposal.
- 14.3. Place all wastes generated during analytical process in properly labeled satellite waste containers for proper collection.
- 14.4. Dispose all unused samples, expired analytical standards and other waste generated during the analytical process in accordance to EMAX-SM03.

**15.0 SUPPLEMENTARY NOTES****15.1. Definition of Terms**

- 15.1.1. **Mercury** – is also known as quicksilver, is a chemical (element) that occurs naturally in the environment in several forms. One form of mercury is used in thermometers. This form is called “metallic mercury”. Mercury is also used in barometers and other common consumer products. Mercury can also be combined with other chemicals, such as chlorine, carbon or oxygen to form either “inorganic” or “organic” mercury compounds.
- 15.1.2. **Analyte** – The specific chemicals or components for which a sample is analyzed; may be a group of chemicals that belong to the same chemical family, and which are analyzed together.
- 15.1.3. **Batch** – is a group of samples that are prepared and/or analyzed at the same time using the same lot of reagents.
  - 15.1.3.1. **Preparation Batch** – is composed of one to 20 samples of the same matrix, a method blank, a lab control sample and matrix spike/matrix spike duplicate.
  - 15.1.3.2. **Analytical Batch** – is composed of prepared samples (extracts, digestates, or concentrates), which are analyzed together as a group using an instrument in conformance to the analytical requirement. An analytical batch can include samples originating from various matrices, preparation batches, and can exceed 20 samples.
- 15.1.4. **Detection Limit (DL)** – is defined as the smallest analyte concentration that can be demonstrated to be different from zero or a blank concentration at the 99% level of confidence. At the DL, the false positive rate (Type I error) is 1%.

## STANDARD OPERATING PROCEDURES

**MERCURY IN LIQUID WASTE**

SOP No.: EMAX-7470 Revision No. 8 Effective Date: 13-Jul-16

---

- 15.1.5. Limit of Detection (LOD) – is defined as the smallest amount or concentration of a substance that must be present in a sample in order to be detected at a high level of confidence (99%). At the LOD, the false negative rate (Type II error) is 1%.
- 15.1.6. Limit of Quantitation (LOQ) – is at the lowest concentration that produces a quantitative result within specified limits of precision and bias. For DoD projects, the LOQ shall be set at or above the concentration of the lowest initial calibration standard.
- 15.1.7. Safety Data Sheet (SDS) – is a written information concerning a chemical physical properties, toxicity, health standards, fire hazard and reactivity data including storage, spill and handling precautions.
- 15.1.8. Calibration – is a determinant measured from a standard to obtain the correct value of an instrument output.
- 15.1.9. Calibration Blank – is a target-analyte-free solvent subjected to the entire analytical process to establish zero baseline or background value.
- 15.1.10. Instrument Method – is a file generated to contain the instrument calibration and instrument parameter settings for a particular analysis.
- 15.1.11. Method Blank – is a target-analyte-free sample subjected to the entire sample preparation and/or analytical to monitor contamination.
- 15.1.12. Lab Control Sample (LCS) – is a target-analyte-free sample spiked with a verified known amount of target analyte(s) or a reference material with a certified known value subjected to the entire sample preparation and/or analytical process. LCS is analyze to monitor the accuracy of the analytical system.
- 15.1.13. Lab Control Sample Duplicate (LCSD) – is a replicate of LCS analyzed to monitor precision in the absence of MS/MSD sample.
- 15.1.14. Sample – is a specimen received in the laboratory bearing a sample label traceable to the accompanying COC. Samples collected in different containers having the same field sample ID are considered the same and therefore labeled with the same lab sample ID unless otherwise specified by the project.
- 15.1.15. Sample Duplicate – is a replicate of a sub-sample taken from one sample, prepared and analyzed within the same preparation batch.
- 15.1.16. Sub-sample – is an aliquot taken from a sample for analysis. Each sub-sample is uniquely identified by the sample preparation ID.
- 15.1.17. Matrix – is a component or form of sample.
- 15.1.18. Matrix Spike (MS) – is a sample spiked with a verified known amount of target analyte(s) subjected to the entire sample preparation and/or analytical process. MS is analyzed to monitor matrix effect on a method's recovery efficiency.
- 15.1.19. Matrix Spike Duplicate (MSD) – is a replicate of MS analyzed to monitor precision or recovery.
- 15.1.20. Reagent Water – Purified water free from any target analyte or any other substances that may interfere with the analytical process.
- 15.2. **Application of EMAX QC Procedures**

## STANDARD OPERATING PROCEDURES

**MERCURY IN LIQUID WASTE**

SOP No.: EMAX-7470 Revision No. 8 Effective Date: 13-Jul-16

---

15.2.1. The procedures and QC criteria summarized in this SOP applies to all projects when performing Mercury analysis by Cold Vapor Absorption Technique. In instances where there is a project or program QAPP, the requirements given in the project takes precedence over this SOP.

**15.3. Department of Defense (DoD) and Department of Energy (DOE) Projects**

15.3.1. Samples from DoD sponsored projects follows the Quality Assurance Project Plan (QAPP), Statement of Work (SOW) and/or client's quality control directive. In the absence of QAPP, the DoD ELAP Quality Systems Manual (QSM), latest update, is applied.

**16.0 REFERENCES**

- 16.1. Method 7470A, Test Methods for Evaluating Solid Wastes, USEPA SW-846, 1992.
- 16.2. EMAX Quality Systems Manual, as updated.

**17.0 APPENDICES****17.1. Figures**

- 17.1.1. Figure 1 Autosampler Layout
- 17.1.2. Figure 2 Typical Calibration Curve
- 17.1.3. Figure 3 Typical Sample Result Summary
- 17.1.4. Figure 4 Typical LCS/LCSD Summary
- 17.1.5. Figure 5 Typical MS/MSD Summary
- 17.1.6. Figure 6 Typical Analytical Spike Summary
- 17.1.7. Figure 7 Typical Dilution Test Summary
- 17.1.8. Figure 6 Typical Case Narrative

**17.2. Appendices**

- 17.2.1. Appendix 1 Summary of Quality Control Procedures
- 17.2.2. Appendix 2 Demonstration of Capability

**17.3. Forms**

- 17.3.1. 7470FS Sample Preparation Log
- 17.3.2. 7470FA Analytical Run Log
- 17.3.3. 7470FM Instrument Maintenance Log

Figure 1: AUTOSAMPLER LAYOUT

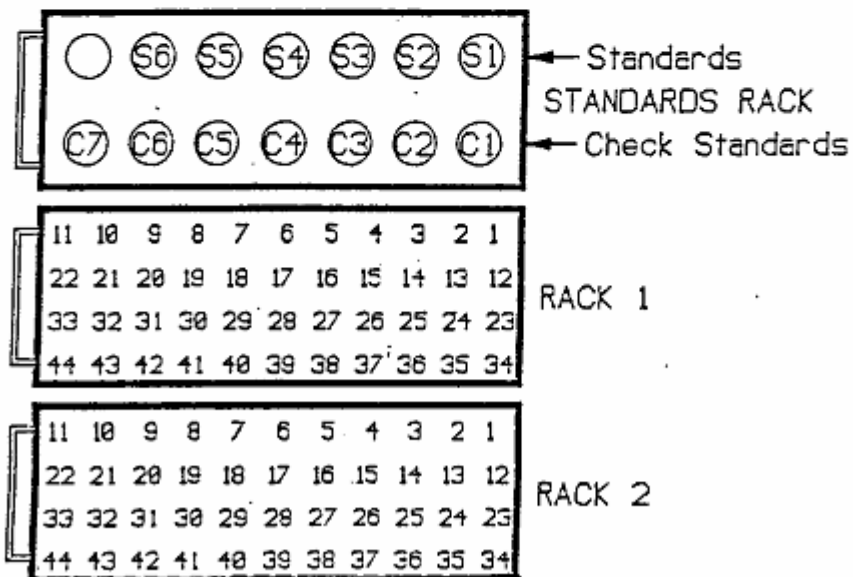
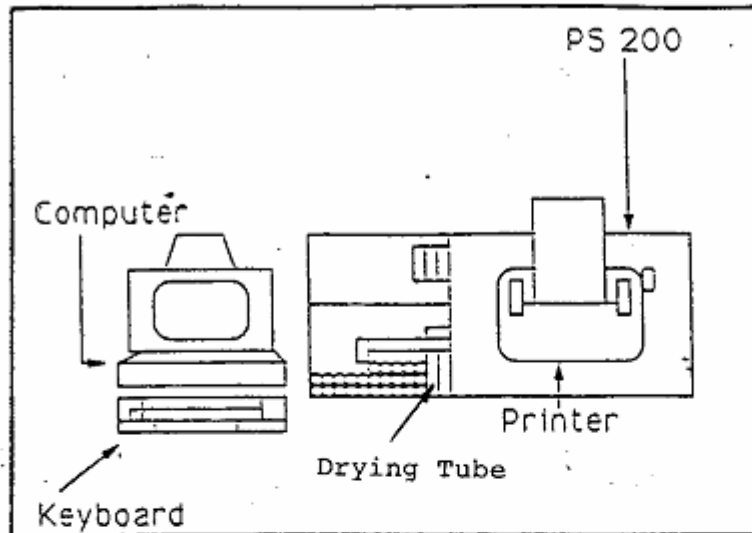

Autosampler layout

**Figure 2: TYPICAL CALIBRATION CURVE**

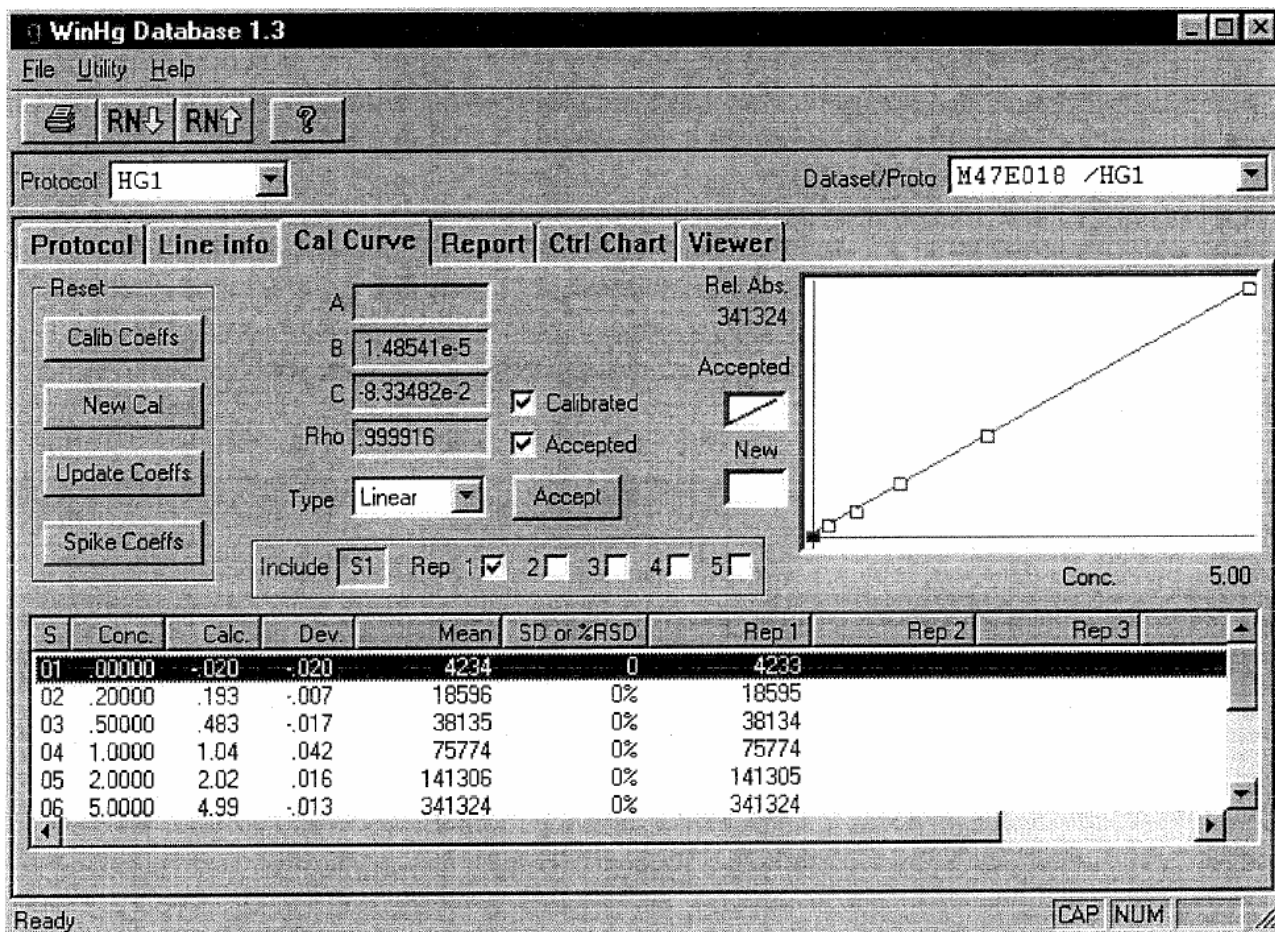

**Figure 3: TYPICAL SAMPLE RESULT SUMMARY**

METHOD SW7470A  
 MERCURY BY COLD VAPOR

|           |               |              |         |
|-----------|---------------|--------------|---------|
| Client    | : XYZ, INC.   | Matrix       | : WATER |
| Project   | : CLEAN WATER | InstrumentID | : 47    |
| Batch No. | : 16E175      |              |         |

| CLIENT<br>SAMPLE ID | EMAX<br>SAMPLE ID | RESULTS<br>(ug/L) | DIL 'N<br>FACTOR | MOIST<br>(%) | LOQ<br>(ug/L) | DL<br>(ug/L) | LOD<br>(ug/L) | ANALYSIS<br>DATETIME | PREPARATION<br>DATETIME | DATA<br>FILE ID | CAL<br>REF | PREP<br>BATCH | COLLECTION<br>DATETIME | RECEIVED<br>DATETIME |
|---------------------|-------------------|-------------------|------------------|--------------|---------------|--------------|---------------|----------------------|-------------------------|-----------------|------------|---------------|------------------------|----------------------|
| MBLK1W              | HGE027WB          | ND                | 1                | NA           | 0.50          | 0.054        | 0.10          | 05/31/1620:45        | 05/31/1614:00           | M47E018043      | M47E018    | HGE027W       | NA                     | NA                   |
| LCS1W               | HGE027WL          | 2.48              | 1                | NA           | 0.50          | 0.054        | 0.10          | 05/31/1620:47        | 05/31/1614:00           | M47E018044      | M47E018    | HGE027W       | NA                     | NA                   |
| LCD1W               | HGE027WC          | 2.46              | 1                | NA           | 0.50          | 0.054        | 0.10          | 05/31/1620:54        | 05/31/1614:00           | M47E018047      | M47E018    | HGE027W       | NA                     | NA                   |
| 03M08-2016S         | E175-08           | ND                | 1                | NA           | 0.50          | 0.054        | 0.10          | 05/31/1620:58        | 05/31/1614:00           | M47E018049      | M47E018    | HGE027W       | 05/18/1614:28          | 05/20/16             |
| 03M08-2016SMS       | E175-08M          | 2.59              | 1                | NA           | 0.50          | 0.054        | 0.10          | 05/31/1621:03        | 05/31/1614:00           | M47E018051      | M47E018    | HGE027W       | 05/18/1614:28          | 05/20/16             |
| 03M08-2016MSD       | E175-08S          | 2.59              | 1                | NA           | 0.50          | 0.054        | 0.10          | 05/31/1621:05        | 05/31/1614:00           | M47E018052      | M47E018    | HGE027W       | 05/18/1614:28          | 05/20/16             |
| 03M12B-2016S        | E175-01           | ND                | 1                | NA           | 0.50          | 0.054        | 0.10          | 05/31/1621:07        | 05/31/1614:00           | M47E018053      | M47E018    | HGE027W       | 05/18/1611:16          | 05/20/16             |
| 03M12B-2016S-9      | E175-02           | ND                | 1                | NA           | 0.50          | 0.054        | 0.10          | 05/31/1621:10        | 05/31/1614:00           | M47E018054      | M47E018    | HGE027W       | 05/18/1611:16          | 05/20/16             |
| 03M04B-2016S        | E175-03           | ND                | 1                | NA           | 0.50          | 0.054        | 0.10          | 05/31/1621:12        | 05/31/1614:00           | M47E018055      | M47E018    | HGE027W       | 05/18/1612:56          | 05/20/16             |
| 03M11B-2016S        | E175-04           | ND                | 1                | NA           | 0.50          | 0.054        | 0.10          | 05/31/1621:14        | 05/31/1614:00           | M47E018056      | M47E018    | HGE027W       | 05/18/1614:42          | 05/20/16             |
| 03M10-2016S         | E175-05           | ND                | 1                | NA           | 0.50          | 0.054        | 0.10          | 05/31/1621:21        | 05/31/1614:00           | M47E018059      | M47E018    | HGE027W       | 05/18/1616:22          | 05/20/16             |
| 03Mw20-2016S        | E175-06           | ND                | 1                | NA           | 0.50          | 0.054        | 0.10          | 05/31/1621:23        | 05/31/1614:00           | M47E018060      | M47E018    | HGE027W       | 05/18/1611:28          | 05/20/16             |
| 03M18-2016S         | E175-07           | ND                | 1                | NA           | 0.50          | 0.054        | 0.10          | 05/31/1621:25        | 05/31/1614:00           | M47E018061      | M47E018    | HGE027W       | 05/18/1611:35          | 05/20/16             |
| 03M19-2016S         | E175-09           | ND                | 1                | NA           | 0.50          | 0.054        | 0.10          | 05/31/1621:27        | 05/31/1614:00           | M47E018062      | M47E018    | HGE027W       | 05/19/1611:17          | 05/20/16             |

Figure 4:

TYPICAL LCS/LCSD SUMMARY

EMAX QUALITY CONTROL DATA  
 LAB CONTROL SAMPLE ANALYSIS

CLIENT : XYZ, INC.  
 PROJECT : CLEAN WATER  
 BATCH NO. : 16E175  
 METHOD : SW7470A

MATRIX : WATER % MOISTURE: N/A  
 DILUTION FACTOR: 1 1 1  
 SAMPLE ID : MBLK1W LCS1W LCD1W  
 LAB SAMPLE ID : HGE027WB HGE027WL HGE027WC  
 LAB FILE ID : M47E018043 M47E018044 M47E018047  
 DATE PREPARED : 05/31/1614:00 05/31/1614:00 05/31/1614:00  
 DATE ANALYZED : 05/31/1620:45 05/31/1620:47 05/31/1620:54  
 PREP BATCH : HGE027W HGE027W HGE027W  
 CALIBRATION REF: M47E018 M47E018 M47E018

ACCESSION:

| PARAMETER | MB RESULT<br>(ug/L) | SPIKE AMT<br>(ug/L) | BS RESULT<br>(ug/L) | BS REC<br>(%) | SPIKE AMT<br>(ug/L) | BSD RESULT<br>(ug/L) | BSD REC<br>(%) | RPD<br>(%) | QC LIMIT<br>(%) | MAX RPD<br>(%) |
|-----------|---------------------|---------------------|---------------------|---------------|---------------------|----------------------|----------------|------------|-----------------|----------------|
| Mercury   | ND                  | 2.50                | 2.48                | 99            | 2.50                | 2.46                 | 98             | 1          | 80-120          | 20             |

**Figure 5: TYPICAL MS/MSD SUMMARY**

EMAX QUALITY CONTROL DATA  
 MS/MSD ANALYSIS

CLIENT : XYZ, INC.  
 PROJECT : CLEAN WATER  
 BATCH NO. : 16E175  
 METHOD : SW7470A

MATRIX : WATER  
 DILUTION FACTOR: 1  
 SAMPLE ID : 03M08-2016S  
 LAB SAMPLE ID : E175-08  
 LAB FILE ID : M47E018049  
 DATE PREPARED : 05/31/1614:00  
 DATE ANALYZED : 05/31/1620:58  
 PREP BATCH : HGE027W  
 CALIBRATION REF: M47E018

1  
 03M08-2016SMS  
 E175-08M  
 M47E018051  
 05/31/1614:00  
 05/31/1621:03  
 HGE027W  
 M47E018

% MOISTURE: NA  
 1  
 03M08-2016SMSD  
 E175-08S  
 M47E018052  
 05/31/1614:00  
 05/31/1621:05  
 HGE027W  
 M47E018

ACCESSION:

| PARAMETER | PARENT RESULT<br>(ug/L) | SPIKE AMT<br>(ug/L) | MS RESULT<br>(ug/L) | MS REC<br>(%) | SPIKE AMT<br>(ug/L) | MSD RESULT<br>(ug/L) | MSD REC<br>(%) | RPD<br>(%) | QC LIMIT<br>(%) | MAX RPD<br>(%) |
|-----------|-------------------------|---------------------|---------------------|---------------|---------------------|----------------------|----------------|------------|-----------------|----------------|
| Mercury   | ND                      | 2.50                | 2.59                | 104           | 2.50                | 2.59                 | 104            | 0          | 80-120          | 20             |



**Figure 6: TYPICAL ANALYTICAL SPIKE SUMMARY**

EMAX QUALITY CONTROL DATA  
 ANALYTICAL SPIKE ANALYSIS

CLIENT : XYZ, INC.  
 PROJECT : CLEAN WATER  
 BATCH NO. : 16E175  
 METHOD : SW7470A

MATRIX : WATER % MOISTURE: NA  
 DILUTION FACTOR: 1 1  
 SAMPLE ID : 03M08-2016S 03M08-2016SMS  
 LAB SAMPLE ID : E175-08 E175-08A  
 LAB FILE ID : M47E018049 M47E018048  
 DATE PREPARED : 05/31/1614:00 05/31/1614:00  
 DATE ANALYZED : 05/31/1620:58 05/31/1621:03  
 PREP BATCH : HGE027W HGE027W  
 CALIBRATION REF: M47E018 M47E018

ACCESSION:

| PARAMETER | SMPL RESULT<br>(ug/L) | SPIKE AMT<br>(ug/L) | AS RSLT<br>(ug/L) | MS REC<br>(%) | QC LIMIT<br>(%) |
|-----------|-----------------------|---------------------|-------------------|---------------|-----------------|
| Mercury   | ND                    | 2.50                | 2.58              | 103           | 85-115          |

**Figure 7: TYPICAL DILUTION TEST SUMMARY**

EMAX QUALITY CONTROL DATA  
 SERIAL DILUTION ANALYSIS

CLIENT : XYZ, INC.  
 PROJECT : CLEAN WATER  
 BATCH NO. : 16E175  
 METHOD : SW7470A

MATRIX : WATER % MOISTURE: NA  
 DILUTION FACTOR: 1 1  
 SAMPLE ID : 03M08-2016S 03M08-2016SMS  
 LAB SAMPLE ID : E175-08 E175-08J  
 LAB FILE ID : M47E018049 M47E018050  
 DATE PREPARED : 05/31/1614:00 05/31/1614:00  
 DATE ANALYZED : 05/31/1620:58 05/31/1621:01  
 PREP BATCH : HGE027w HGE027w  
 CALIBRATION REF: M47E018 M47E018

ACCESSION:

| PARAMETER | SMPL RESULT<br>(ug/L) | SERIAL DIL RSLT<br>(ug/L) | DIL RST<br>(%) | QC LIMIT<br>(%) |
|-----------|-----------------------|---------------------------|----------------|-----------------|
| Mercury   | ND                    | ND                        | 0              | 10              |

**Figure 8: TYPICAL CASE NARRATIVE**

---

CASE NARRATIVE

Client : XYZ, INC.

Project: CLEAN WATER

SDG : 16E175

METHOD SW7470A  
MERCURY BY COLD VAPOR

A total of nine (9) water samples were received on 05/20/16 to be analyzed for Mercury by Cold Vapor in accordance with Method SW7470A and project specific requirements.

Holding Time

Samples were digested and analyzed within the prescribed holding time.

Calibration

Multi-calibration points were generated to establish initial calibration (ICAL). ICAL was verified using a secondary source (ICV). Continuing calibration (CCV) verifications were carried on a frequency specified by the project. All calibration requirements were within acceptance criteria.

Method Blank

Method blank was prepared and analyzed at the frequency required by the project. For this SDG, one (1) method blank was analyzed. Mercury was not detected in HGE027WB. Refer to sample result summary form for details.

Lab Control Sample

Lab control sample was prepared and analyzed at a frequency required by the project. For this SDG, one (1) set of LCS/LCD was analyzed. HGE027WL/HGE027WC was within LCS limits. Refer to LCS summary form for details.

Matrix QC Sample

Matrix spike sample was prepared and analyzed at a frequency required by the project. For this SDG, one (1) set of MS/MSD was analyzed. Mercury was within MS QC limits in E175-08M/S. Refer to Matrix QC summary form for details. Analytical spike and serial dilution were analyzed for matrix interference evaluation. Results were within method acceptance criteria.

Sample Analysis

Samples were analyzed according to prescribed analytical procedures. Results were evaluated in accordance to project requirements. For this SDG, all quality control requirements were met.

**Appendix 1:**

**SUMMARY OF QUALITY CONTROL PROCEDURES**

| PARAMETER  | FREQUENCY  | ACCEPTANCE CRITERIA  | CORRECTIVE ACTION   | 1 <sup>st</sup><br>Rvw | 2 <sup>nd</sup><br>Rvw |
|--|--|--|---|------------------------|------------------------|
| Initial multipoint calibration   | Daily initial calibration prior to sample analysis   | Correlation coefficient $r \geq 0.995$ for linear regression | Correct the problem then repeat initial calibration   |                        |                        |
| Initial calibration verification (second source)                               | Daily after initial calibration  | Analyte within $\pm 10\%$ of expected value                  | Correct the problem then repeat initial calibration   |                        |                        |
| Calibration verification (CCV)   | Daily, before sample analysis, every 10 samples and at the end of analysis sequence                                | Analyte within $\pm 10\%$ of expected value                  | Repeat calibration and re-analyze all samples since last successful calibration   |                        |                        |
| Calibration blank (CCB)  | After every calibration verification   | No analyte detected $> LOD$                                  | Correct the problem then re-analyze calibration blank and previous samples  |                        |                        |
| Method blank (MB)  | One per preparation batch  | No analyte detected $> \frac{1}{2} LOQ$                      | Re-prep and re-analyze method blank and all samples processed with the contaminated blank                                       |                        |                        |
| Lab Control Sample (LCS)   | One LCS per preparation batch  | %Rec.: 80-120%   | Re-prep and re-analyze the LCS and all associated samples   |                        |                        |
| MS/MSD or MS/Dup   | One set MS/MSD or MS/Dup in every preparatory batch  | %Rec. 80-120%, RPD $\leq 20\%$                               | Perform Post-Digestion Spike.   |                        |                        |
| Post-Digestion Spike   | When MS/MSD or MS/Dup fails  | %Rec. 85-115%  | Perform dilution test if analyte concentration is sufficiently high ( $\sim 5x$ the LOQ after dilution), otherwise perform MSA. |                        |                        |
| Dilution Test  | When Post-Digestion Spike fails and analyte concentration is sufficiently high ( $\sim 5x$ the LOQ after dilution) | Within $\pm 10\%$ of the parent sample result                | Perform MSA.  |                        |                        |
| Comments: Refer to PSR for flagging criteria<br>LOQ = lowest calibration point |  |  |   | Reviewed By:           |                        |
|  |  |  |   | Date:                  |                        |

**Appendix 2:**

**DEMONSTRATION OF CAPABILITY**

**DEMONSTRATION OF CAPABILITY  
 MERCURY  
 EPA 7470A**

EMAX-7470 Rev. 7  
 Conc Unit: mg/L  
 Sample Amount(mL): 50

Extraction dates: 1/11/2016  
 Analysis dates: 1/11/2016  
 Extracted and Analyzed by: N. Tan

| PARAMETER | HGA006WL   | HGA006WC   | HGA007WL   | HGA007WC   | TV  | Ave.<br>Conc. | Ave.<br>%Rec | SD    | RSD<br>(%) | QC Criteria | COMMENTS |
|-----------|------------|------------|------------|------------|-----|---------------|--------------|-------|------------|-------------|----------|
|           | M47A004012 | M47A004013 | M47A004043 | M47A004044 |     |               |              |       |            |             |          |
| Mercury   | 2.56       | 2.56       | 2.47       | 2.51       | 2.5 | 2.53          | 101          | 0.044 | 2          | 80 - 120    | PASSED   |









## STANDARD OPERATING PROCEDURES

**DIESEL RANGE ORGANICS**

SOP No.: EMAX-8015D Revision No. 7 Effective Date: 20-Sep-17  
 Prepared By: Larisa Ermolova *L. Ermolova* Date: 9/20/17  
 Approved By: Kenette Pimentel *K. Pimentel* Date: 09-20-17  
 QA Manager  
 Approved By: Caspar Pang *C. Pang* Date: 09-20-17  
 Laboratory Director

Control Number: 8015D-07-

**1.0 SCOPE AND APPLICATION**

- 1.1 This method is used to analyze extractable fuel hydrocarbons in water, soil and other sediment samples. In the vast field of petroleum hydrocarbons, this method is limited to provide semi-quantitative results on those extractable hydrocarbons with a comparable aliphatic hydrocarbon range from C<sub>10</sub> to C<sub>34</sub>.
- 1.2 This SOP is an adaptation of SW846 Method 8015C. This SOP is also applicable to SW846 Method 8015B and Method 8015D.

**2.0 SUMMARY OF METHOD**

- 2.1 Petroleum hydrocarbons are extracted in methylene chloride, analyzed by flame ionization detector (FID) in gas chromatograph and quantified as diesel fuel at C<sub>10</sub> to C<sub>28</sub> range. The hydrocarbons that fall in this range are defined as Diesel Range Organics (DRO).
- 2.2 Other fuel standards that fall in the range of C<sub>10</sub> to C<sub>34</sub> can also be quantitated by this method.
- 2.3 **Interference**
- 2.3.1 Glassware can be a potential source of contamination. They must be scrupulously cleaned prior to its use.
- 2.3.2 Carry-over from a highly concentrated sample can be potential source of contamination. Instrument performance must be observed keenly for possible carry-over. If this is apparent, inject solvent blank until no trace of carry-over is observed.
- 2.3.3 Deposits may adhere in the injection port/glass liner over a period of time and can cause interference. The injection port and glass liner must be routinely cleaned.

**3.0 DETECTION LIMITS**

- 3.1 **Detection Limit (DL), Limit of Detection (LOD) and Limit of Quantitation (LOQ)**
- 3.1.1 Refer to EMAX-QA04 for generation, validation and verification for DL, LOD and LOQ.
- 3.1.2 Refer to Table 1 for established limits.

**4.0 DYNAMIC RANGE**

## STANDARD OPERATING PROCEDURES

**DIESEL RANGE ORGANICS**SOP No.: EMAX-8015D Revision No. 7 Effective Date: 20-Sep-17

---

- 4.1 The highest quantifiable range requiring no dilution is equal to the concentration of the highest calibration point (refer to Section 9.5.1). Dilute and re-analyze all samples having results above this range to properly quantitate.
- 4.2 The lowest quantifiable range of diluted samples is equal to the lowest calibration point (refer to Section 9.5.1). Lower the dilution factor and re-analyze all diluted samples analyzed below this range to properly quantitate.

**5.0 SAMPLE HOLDING TIME & PRESERVATION****5.1 Sample Collection**

- 5.1.1 Water samples received in the lab are expected to be contained in an amber bottle with Teflon-lined cap and cooled to  $\leq 6^{\circ}\text{C}$  without freezing.
- 5.1.2 Soil samples received in the lab are expected to be contained in a jar or Shelby tube and cooled to  $\leq 6^{\circ}\text{C}$  without freezing.

**5.2 Holding Time**

- 5.2.1 Water samples must be extracted within 7 days from sampling date.
- 5.2.2 Soil samples must be extracted within 14 days from sampling date.
- 5.2.3 All extracts must be analyzed within 40 days from extraction.

**5.3 Preservation**

- 5.3.1 Store water samples at  $\leq 6^{\circ}\text{C}$  without freezing, store in dark.
- 5.3.2 Store soil samples and extracts at  $\leq 6^{\circ}\text{C}$  without freezing.

**6.0 ASSOCIATED SOPs**

- 6.1 EMAX-3520 Extraction, Continuous Liquid/Liquid
- 6.2 EMAX-3540 Extraction, Soxhlet
- 6.3 EMAX-3550 Extraction, Pulse Sonication
- 6.4 EMAX-3580 Waste Dilution
- 6.5 EMAX-DM01 Data Flow & Review
- 6.6 EMAX-QA04 Detection Limit (DL)
- 6.7 EMAX-QA05 Training
- 6.8 EMAX-QA08 Corrective Action
- 6.9 EMAX-QC01 Quality Control for Chemicals
- 6.10 EMAX-QC02 Analytical Standard Preparation
- 6.11 EMAX-QC07 Glassware Cleaning
- 6.12 EMAX-SM01 Sample Management

## STANDARD OPERATING PROCEDURES

**DIESEL RANGE ORGANICS**SOP No.: EMAX-8015D Revision No. 7 Effective Date: 20-Sep-17

- 6.13 EMAX-SM03 Waste Disposal
- 6.14 EMAX-SM04 Analytical and QC Sample Labeling

**7.0 SAFETY**

- 7.1 Read all SDS for chemicals listed in this SOP.
- 7.2 Treat reagents, standards and samples as potential hazard. Observe the standard laboratory safety procedures. Wear protective gear, i.e., lab coat, safety glasses, gloves, at all times when performing this procedure. Perform all sample and standard handling in the fume hood.
- 7.3 If for any reason, solvent and/or other reagents get in contact with your skin or any other part of your body, rinse the affected body part thoroughly with copious amounts of water. If irritations persist, inform your supervisor immediately so that proper action can be taken.

**8.0 INSTRUMENT, CHEMICALS & REAGENTS****8.1 Instruments and Supplies****8.1.1 Gas Chromatography**

| Instrument ID                      | Inst. D5                            | Inst. F2                       |
|------------------------------------|-------------------------------------|--------------------------------|
| Gas Chromatography and Autosampler | Agilent 6890 with 7683B autosampler | Perkin Elmer Clarus 680        |
| Detector                           | FID                                 | FID                            |
| Column                             | HP-5 30m x 0.32 x 0.25 $\mu$ m      | HP-5 30m x 0.32 x 0.25 $\mu$ m |
| Data Acquisition                   | EZChrom Elite 3.3.1                 | EZChrom Elite 3.3.2            |

8.1.2 Syringes: 10, 50, 100, 250, 500, 1000  $\mu$ l microsyringe

8.1.3 Volumetric Flask: 10, 50, 100 and 1000 ml

8.1.4 Vials: 2, 10 and 40 ml, amber

8.1.5 Bottle: 125, 250 ml (amber)

**8.2 Chemicals and Reagents**

8.2.1 Where available, purchase reagent-grade chemicals and reagents.

8.2.2 Methylene Chloride

8.2.3 Acetone, Methanol

8.2.4 High purity He, H<sub>2</sub>, Air, N<sub>2</sub>

**9.0 STANDARDS****9.1 Standard Preparation**

9.1.1 Refer to EMAX-QC02 for proper analytical standard preparation.

## STANDARD OPERATING PROCEDURES

**DIESEL RANGE ORGANICS**SOP No.: EMAX-8015D Revision No. 7 Effective Date: 20-Sep-17

9.1.2 Other concentration levels may be prepared as long as it complies with the method and project requirements.

9.2 **Stock Standard**

9.2.1 Diesel

Purchase stock standards as certified solutions from certified vendors as suggested below or equivalent:

| Standard Name  | Source | Concentration (mg/L) | Solvent                          | Intended Use          |
|--|--------|----------------------|----------------------------------|-----------------------|
| Diesel   | Restek | 50,000               | MeCl <sub>2</sub>                | ICAL, DCC             |
| Diesel   | CPI    | 50,000               | Acetone                          | ICV, LCS/LCSD, MS/MSD |
| Bromobenzene (C <sub>6</sub> H <sub>5</sub> Br)<br>Hexacosane (C <sub>26</sub> H <sub>54</sub> ) | CPI    | 2000<br>500          | Acetone/MeCl <sub>2</sub><br>1:1 | Surrogates            |

9.2.2 JP5 and Motor Oil

Purchase stock standards as certified solutions from certified vendors as suggested below or equivalent:

| Standard Name      | Source       | Concentration (mg/L) | Solvent           | Intended Use          |
|--------------------|--------------|----------------------|-------------------|-----------------------|
| JP-5 Military Fuel | Supelco      | 10,000               | MeCl <sub>2</sub> | ICAL, DCC             |
| JP-5               | AccuStandard | 20,000               | Methanol          | ICV, LCS/LCSD, MS/MSD |
| Motor Oil 5W30     | Restek       | 50,000               | MeCl <sub>2</sub> | ICAL, DCC             |
| SAE 5W30 Motor Oil | AccuStandard | Neat                 | NA                | ICV, LCS/LCSD, MS/MSD |

9.3 **Intermediate Standard**

9.3.1 Prepare SAE 5W30 Motor Oil Standard with Methylene Chloride as suggested below:

| Standard Name      | Concentration | Amount | Final Conc.  | Solvent           | Final Volume |
|--------------------|---------------|--------|--------------|-------------------|--------------|
| SAE 5W30 Motor Oil | Neat          | 1.0 g  | 100,000 mg/L | MeCl <sub>2</sub> | 10 ml        |

9.3.2 Prepare Motor Oil working standard as suggested below:

| Standard Name   | Concentration | Amount | Final Conc. | Solvent | Final Volume |
|-----------------|---------------|--------|-------------|---------|--------------|
| Motor Oil Spike | 100,000 mg/L  | 5.0 ml | 5,000 mg/L  | Acetone | 100 ml       |

9.4 **Calibration Standard**

9.4.1 Initial Calibration Standard

9.4.1.1 **Diesel**

Prepare a minimum of 5-point calibration standard (ideally 6-point) from the primary stock standard in MeCl<sub>2</sub> and store in Teflon-sealed vial with minimal headspace; suggested concentration and injection volume are as follows:

## STANDARD OPERATING PROCEDURES

**DIESEL RANGE ORGANICS**SOP No.: EMAX-8015D Revision No. 7 Effective Date: 20-Sep-17

| ICAL Pt. | Diesel<br>(50,000 mg/L)<br>Aliquot ( $\mu$ l) | Bromobenzene/<br>Hexacosane<br>(2000/500 mg/L)<br>Aliquot ( $\mu$ l) | Final<br>Volume<br>(ml) | Final Concentration (mg/L) |              |            |
|----------|---|--|-------------------------|----------------------------|--------------|------------|
|          |   |  |                         | Diesel                     | Bromobenzene | Hexacosane |
| 1        | 0.1   | 0  | 1                       | 5                          | 0            | 0          |
| 2        | 0.4   | 10   | 1                       | 20                         | 20           | 5          |
| 3        | 1   | 20   | 1                       | 50                         | 40           | 10         |
| 4        | 10  | 40   | 1                       | 500                        | 80           | 20         |
| 5        | 20  | 50   | 1                       | 1000                       | 100          | 25         |
| 6        | 40  | 60   | 1                       | 2000                       | 120          | 30         |
| 7        | 60  | 110  | 1                       | 3000                       | 220          | 55         |

## 9.4.1.2 JP5

Prepare a minimum of 5-point calibration standard (ideally 6-point) from the primary stock standard in MeCl<sub>2</sub> and store in Teflon-sealed vial with minimal headspace

| ICAL Pt. | Stock Standard<br>(10,000 mg/L)<br>Aliquot ( $\mu$ l) | Final Volume<br>(ml) | Final Concentration<br>(mg/L) |
|----------|---|----------------------|-------------------------------|
| 1        | 1   | 1                    | 10                            |
| 2        | 5   | 1                    | 50                            |
| 3        | 10  | 1                    | 100                           |
| 4        | 50  | 1                    | 500                           |
| 5        | 150   | 1                    | 1500                          |
| 6        | 300   | 1                    | 3000                          |

## 9.4.1.3 Motor Oil

Prepare a minimum of 5-point calibration standard (ideally 6-point) from the primary stock standard in MeCl<sub>2</sub> and store in Teflon-sealed vial with minimal headspace

| ICAL Pt. | Stock Standard<br>(50,000 mg/L)<br>Aliquot ( $\mu$ l) | Final Volume<br>(ml) | Final Concentration<br>(mg/L) |
|----------|---|----------------------|-------------------------------|
| 1        | 0.2   | 1                    | 10                            |
| 2        | 1   | 1                    | 50                            |
| 3        | 2   | 1                    | 100                           |
| 4        | 10  | 1                    | 500                           |
| 5        | 30  | 1                    | 1500                          |

## STANDARD OPERATING PROCEDURES

**DIESEL RANGE ORGANICS**SOP No.: EMAX-8015D Revision No. 7 Effective Date: 20-Sep-17

| ICAL Pt. | Stock Standard<br>(50,000 mg/L)<br>Aliquot (µl) | Final Volume<br>(ml) | Final Concentration<br>(mg/L) |
|----------|---|----------------------|-------------------------------|
| 6        | 60  | 1                    | 3000                          |

9.4.2 Initial Calibration Verification Standard

## 9.4.2.1 Diesel

Prepare initial calibration verifications standard using secondary source standard in MeCl<sub>2</sub>.

| Diesel Std.<br>(50,000 mg/L)<br>Aliquot (µl) | Bromobenzene /<br>Hexacosane<br>(2000 / 500 mg/L)<br>Aliquot (µl) | Final Volume<br>(ml) | Final Conc.<br>Analyte/Surrogates<br>(mg/L) |
|--|---|----------------------|---|
| 10   | 40  | 1                    | 500 / 80 / 20                               |

## 9.4.2.2 JP5/Motor Oil

Prepare initial calibration verifications standard using secondary source standard in MeCl<sub>2</sub>.

| JP5 Std.<br>(20,000 mg/L)<br>Aliquot (µl) | Motor Oil Std.<br>(Intermediate Std.)<br>(5,000 mg/L)<br>Aliquot (µl) | Final Volume<br>(ml) | Final Conc.<br>JP5/Motor Oil<br>(mg/L) |
|---|---|----------------------|--|
| 25  | 100   | 1                    | 500 / 500                              |

9.4.3 Continuing Calibration Standard

## 9.4.3.1 Diesel

Prepare daily calibration standards using primary-source standards in MeCl<sub>2</sub>.

| Diesel Std.<br>(50,000 mg/L)<br>Aliquot (µl) | (2000 / 500 mg/L)<br>Aliquot (µl) | Final Volume<br>(ml) | Final Conc.<br>Diesel/Surrogates<br>(mg/L) |
|--|-----------------------------------|----------------------|--|
| 100  | 400                               | 10                   | 500 / 80/20                                |

## 9.4.3.2 JP5/Motor Oil

Prepare daily calibration standards using primary-source standards in MeCl<sub>2</sub>.

| JP5 Std.<br>(10,000 mg/L)<br>Aliquot (µl) | Motor Oil Std.<br>(50,000 mg/L)<br>Aliquot (µl) | Final Volume<br>(ml) | Final Conc.<br>JP5/Motor<br>Oil/Surrogates<br>(mg/L) |
|---|---|----------------------|--|
| 500                                       | 100   | 10                   | 500 / 500  |

## STANDARD OPERATING PROCEDURES

**DIESEL RANGE ORGANICS**SOP No.: EMAX-8015D Revision No. 7 Effective Date: 20-Sep-17**9.5 LCS/MS Spike Standard**

9.5.1 Use secondary source standards or primary source standards for laboratory control standard (LCS) and matrix spike (MS) standards.

**9.6 Retention Time Window Standard**

9.6.1 Purchase stock n-alkane standards as suggested below or equivalent.

| Standard Name   | Source       | Concentration | Solvent    |
|---|--------------|---------------|------------|
| Calibration Window Defining Hydrocarbon (C <sub>8</sub> – C <sub>40</sub> ) | AccuStandard | 1000          | Chloroform |
| Hydrocarbon Window Defining Standard (C <sub>9</sub> – C <sub>39</sub> )    | AccuStandard | 500           | Hexane     |

9.6.2 Prepare working n-alkane standards with MeCl<sub>2</sub> as follows:

| Standard Name                            | Concentration | Amount | Final Volume | Final Concentration |
|--|---------------|--------|--------------|---------------------|
| C <sub>8</sub> -C <sub>40</sub> RTW Std. | 1000 mg/L     | 0.2 ml | 10 ml        | 20 mg/L             |
| C <sub>9</sub> -C <sub>39</sub> RTW Std. | 500 mg/L      | 0.4 ml |              | 20 mg/L             |

**10.0 PROCEDURES****10.1 Sample Preparation****10.1.1 Aqueous Samples**

10.1.1.1 Prepare aqueous samples in accordance with EMAX-3520, unless otherwise specified by the project.

**10.1.2 Soil Samples**

10.1.2.1 Prepare soil samples in accordance with any of the following extraction procedures: EMAX-3540, EMAX-3550 or EMAX-3580 as specified by the project. Where project does not specify extraction procedure, default to EMAX-3550.

**10.2 Instrument Parameters**

10.2.1 Fine tune the instrument guided by parameter conditions as listed below:

Injector Temperature – 280°C

Detector Temperature – 320°C

Head Pressure – 21 psi

Temperature Program

| Instrument          | D5                     | F2                     |
|---------------------|------------------------|------------------------|
| Initial Temperature | 55°C, hold for 0.5 min | 60°C, hold for 0.5 min |
| Temperature 1       | 320°C, hold for 5 min  | 310°C, hold for 4 min  |

## STANDARD OPERATING PROCEDURES

**DIESEL RANGE ORGANICS**SOP No.: EMAX-8015D Revision No. 7 Effective Date: 20-Sep-17

|                |           |                       |
|----------------|-----------|-----------------------|
| Rate 1         | 60°C /min | 55°C /min             |
| Temperature 2  | -         | 320°C, hold for 2 min |
| Rate 2         | -         | 60°C /min             |
| Total Run Time | 10 min    | 12 min                |

**10.3 Calibration****10.3.1 Initial Calibration**

10.3.1.1 Analyze the initial calibration standards prepared. Sum the area of all peaks eluting between C<sub>10</sub> to C<sub>28</sub> for each of the calibration point. Generate this area by rejoining a horizontal baseline between the retention time of C<sub>10</sub> to C<sub>28</sub>. Check that the highest point does not have saturated peak(s).

*Note: The lowest calibration determines the limit of quantitation (LOQ). Therefore, check that the LOQ is in conformance to the current projects where the ICAL will be used.*

**10.3.2 Initial Calibration Verification (ICV)**

10.3.2.1 After establishing ICAL, analyze the ICV standard (Refer to Section 9.4.2) to verify the validity of the ICAL. Refer to Appendix 1 for acceptance criteria. If non-compliant, refer to Section 12 for corrective action.

**10.3.3 Retention Time Window Check (RTW)**

10.3.3.1 Analyze the RTW standard after every ICAL to set carbon cut-off ranges (e.g., C<sub>10</sub>-C<sub>24</sub>, C<sub>10</sub>-C<sub>28</sub>). Refer to Section 9.6.

**10.3.4 Daily Continuing Calibration (DCC)**

10.3.4.1 Analyze a continuing calibration (Refer to 9.4.3) at the beginning of a 12-hour shift or as specified by the project.

10.3.4.2 Refer to Appendix 1 for acceptance criteria and corrective action.

**10.4 Analysis****10.4.1 Extract Preparation**

10.4.1.1 Allow the extracts to equilibrate to room temperature.

10.4.1.2 Transfer about 1 ml of extracts into autosampler vials.

**10.4.2 Analytical Sequence**

10.4.2.1 Analyze instrument blank to ensure that the instrument is free from contamination.

10.4.2.2 Analyze DCC to check ICAL validity.

10.4.2.3 Analyze Method Blank to check for preparation batch contamination.

10.4.2.4 Analyze Lab Control Sample to check accuracy.

10.4.2.5 Analyze Lab Control Sample Duplicate (if required by the project).

10.4.2.6 Analyze samples to a maximum of 12-hour runs or as specified by the project.



## STANDARD OPERATING PROCEDURES

**DIESEL RANGE ORGANICS**

SOP No.: EMAX-8015D Revision No. 7 Effective Date: 20-Sep-17

---

10.4.2.7 Analyze matrix spikes (MS/MSD) per project requirement.

10.4.2.8 Record the analytical sequence in the Analytical Run Log.

10.4.2.9 Print instrument sequence before and after the analysis run and attach to the analytical run. Document any changes that occurred during the process.

10.4.3 **Identification and Quantitation**

10.4.3.1 Identification is based on pattern recognition. Hence, compare sample chromatograms to reference hydrocarbons standard chromatograms for their response hydrocarbon range and peak distribution to determine the most probable petroleum product.

10.4.3.2 All peaks eluting within the established RT window identifies the DRO, JP5 and Motor Oil.

10.4.3.3 When the elution profile of a sample does not match that of diesel standard, JP5 or motor oil, but falls within the retention time window, quantitate results as diesel range organics (DRO) and denote the observed deviation in case narrative.

10.4.3.4 Quantitation is achieved by the summation of all peaks in the chromatogram minus the solvent peak, and the sample result is calculated using Eq.-10.5.3.

10.4.3.5 Integrate the total peak area response and quantitate the total area by using the ACF of Diesel, JP5 or Motor Oil (refer to Eq.-10.5.1.2).

10.4.3.6 When manual integration is necessary follow the procedures described in EMAX-DM01 (Section for manual integration).

10.4.4 **Retention Time Window (RTW)**

10.4.4.1 **Establishing RTW**

10.4.4.1.1 Run RTW standard over a period of 72 hours.

10.4.4.1.2 Calculate the Standard Deviation (SD) of absolute retention time obtained for each analyte (use Eq.-10.5.1.3).

10.4.4.1.3 The width of RTW is defined by  $\pm 3XSD$ .

10.4.4.2 **Evaluating RTW**

10.4.4.2.1 If the SD is equal to 0.00, default to the previous study until historical data is obtained to define the RTW for the current instrument.

10.4.4.2.2 For new instruments, use the established retention time from another instrument having the same instrument parameters (e.g. detector, temperature program and column). If there are no instruments with the same instrument parameter, use 0.03 minutes as the default RTW until historical data is obtained to define the RTW for the current instrument parameters condition.

10.4.4.3 **Application of RTW**

10.4.4.3.1 Establish the center of absolute retention time for each analyte to include the surrogate(s) from the daily calibration check at the beginning of the analytical shift then apply the established RTW.

## STANDARD OPERATING PROCEDURES

**DIESEL RANGE ORGANICS**SOP No.: EMAX-8015D Revision No. 7 Effective Date: 20-Sep-17

10.4.4.3.2 Whenever the observed retention is outside the established RTW, the analyst is advised to determine the cause and perform necessary corrective action before continuing analyses.

**10.4.4.4 Updating RTW**

10.4.4.4.1 Re-establish the RTW as described in Section 10.4.4.1 when any of the following conditions occur.

- Yearly RTW update
- Significant shifting is observed (e.g. succeeding calibration checks or LCS are out of the RTW)
- Major instrument maintenance (e.g. replacement of detector).

10.4.4.4.2 If the calculated new RTW is significantly narrower than the previously established RTW, default to the previously established RTW.

**10.4.5 Sample Result Evaluation**

10.4.5.1 Check QC Criteria as soon as available.

- Check LCS, MS surrogate recoveries against Project Specific Requirement (PSR). In the absence of PSR, default to in-house QC limits. Refer to Appendix 1.

**10.4.5.2 Qualitative Identification**

- Compare the sample chromatogram to the pattern established by the calibration standard.
- When peaks other than diesel pattern are detected within the DRO, take note of it and discuss in the case narrative.

**10.4.5.3 Quantitation**

- Assign the appropriate hydrocarbon range for quantitation (e.g. C<sub>10</sub> – C<sub>28</sub>; C<sub>18</sub> – C<sub>34</sub>; C<sub>8</sub>-C<sub>18</sub>; etc.).
- Integrate all peaks bracketed by the hydrocarbon range baseline to the baseline. Set the integration range at least 95% within of the total spectrum of the expected DRO range.
- Calculate the result as specified in Figure 2 based on the appropriate fuel standard (e.g. Diesel: C<sub>10</sub> – C<sub>28</sub>; Motor Oil: C<sub>18</sub> – C<sub>34</sub>; JP5 C<sub>8</sub>-C<sub>18</sub>). In the absence of alkane range specification for the project, request for directive from the PM.
- Check that all positively identified target analytes are quantitated within the calibration range.
- Dilute and re-analyze all positively identified target analytes exceeding calibration range.
- When peaks other than diesel pattern are detected within the DRO range, quantitate using the DRO calibration factor and discuss it in the case narrative (e.g. peaks within the DRO range does not resemble diesel pattern or motor oil pattern).

## STANDARD OPERATING PROCEDURES

**DIESEL RANGE ORGANICS**SOP No.: EMAX-8015D Revision No. 7 Effective Date: 20-Sep-17

When saturated peaks are present, dilute the extract appropriately until peaks are eluted properly.

**10.5 Calculations****10.5.1 Initial Calibration****10.5.1.1 Calculate for Calibration Factor (CF)**

$$CF = \frac{R_t}{C_v} \quad \text{Eq.10.5.1.1}$$

where:

- $R_t$  – Total response of the integrated peaks  
 $C_v$  – Known value of the standard concentration, mg/L

**10.5.1.2 Calculate for the Average Calibration Factor (ACF)**

$$ACF = \frac{\sum CF}{n} \quad \text{Eq.-10.5.1.2}$$

where:

- $\sum CF$  – Summation of Calibration Factors  
 $n$  – Number of measurements

**10.5.1.3 Calculate for Standard Deviation (SD)**

$$SD = \sqrt{\frac{\sum_{i=1}^n (x_i - \bar{x})^2}{n-1}} \quad \text{Eq.-10.5.1.3}$$

where:

- $X_i$  – Result at the  $i^{\text{th}}$  measurement  
 $\bar{x}$  – Mean  
 $n$  – Number of measurements

**10.5.1.4 Calculate for Percent Relative Standard Deviation (%RSD)**

$$\%RSD = \frac{SD}{ACF} \times 100 \quad \text{Eq.-10.5.1.4}$$

where:

- $SD$  – Standard deviation  
 $ACF$  – Average Calibration Factor

**10.5.2 Calculate the Percent Difference of DCC from ACF**

## STANDARD OPERATING PROCEDURES

**DIESEL RANGE ORGANICS**SOP No.: EMAX-8015D Revision No. 7 Effective Date: 20-Sep-17

$$\%D = \frac{C_f - C_k}{C_k} * 100 \quad \text{Eq.-10.5.2}$$

where:

- $\%D$  – Percent Difference DCC from known concentration
- $C_k$  – Known concentration of the analyte, in mg/L
- $C_f$  – Found concentration, in mg/L

**10.5.3 Calculate for Sample Concentration****10.5.3.1 Water Samples**

$$C = \frac{(R_t)(V_e)(DF)}{(ACF)(A_s)} \quad \text{Eq.-10.5.3.1}$$

where:

- $C$  – Concentration of the sample, mg/L
- $R_t$  – Total response of the integrated peaks
- $V_e$  – Volume of Extract, ml
- $A_s$  – Sample amount, ml
- $DF$  – Dilution Factor
- $ACF$  – Average Calibration Factor

**10.5.3.2 Soil Samples**

$$C = \frac{(R_t)(V_e)(DF)}{(ACF)(A_s)(\%S)} \quad \text{Eq.-10.5.3.2}$$

where:

- $C$  – Concentration of the sample, mg/Kg
- $R_t$  – Total response of the integrated peaks
- $V_e$  – Volume of Extract, ml
- $A_s$  – Sample amount, g
- $DF$  – Dilution Factor
- $ACF$  – Average Calibration Factor
- $\%S$  – Percent solids (%S of water = 1)

**10.5.4 Percent Recovery**

$$\% \text{ Recovery} = \frac{(C_f - C)}{C_s} \times 100 \quad \text{Eq.-10.5.4}$$

## STANDARD OPERATING PROCEDURES

**DIESEL RANGE ORGANICS**SOP No.: EMAX-8015D Revision No. 7 Effective Date: 20-Sep-17

where:

- $C_f$  - Concentration found  
 $C$  - Concentration of the sample (use 0 for LCS)  
 $C_s$  - Concentration of spike

10.5.5 Relative Percent Difference (RPD)

$$RPD = \frac{|C_1 - C_2|}{\left(\frac{C_1 + C_2}{2}\right)} \times 100 \quad \text{Eq.-10.5.5}$$

where:

- $C_1$  - Measured concentration of the first sample aliquot  
 $C_2$  - Measured concentration of the second sample aliquot

10.6 **Data Reduction**

- 10.6.1 Make a copy of the analytical run log.  
 10.6.2 Print a copy of the raw data and the QC report.  
 10.6.3 Highlight the data to be reported.  
 10.6.4 Collate the reportable data separating the QC results from the sample results.  
 10.6.5 Keep all other data generated with the analytical folder marked with "For record only".

10.7 **Report Generation**

- 10.7.1 Generate the method.txt file using WDBX<sup>1</sup>CN.exe.  
 10.7.2 Generate the sample results using F1NVX<sup>1</sup>C.exe or F1NVX<sup>1</sup>C4.exe.  
 10.7.3 Generate the QC summary using QCVX<sup>1</sup>CN.exe or QCVX<sup>1</sup>CN4.exe.  
 10.7.4 Generate the Lab Chronicle using LABCHRN1.exe.  
 10.7.5 Generate the Case Narrative using CN00.exe.

10.8 **Data Review**

- 10.8.1 Arrange the analysis package in sequence as detailed below using section separators. Attach all raw data to every form generated, to include manual integration(s) and re-analysis.
- 10.8.1.1 Case Narrative
  - 10.8.1.2 Lab Chronicle
  - 10.8.1.3 Sample Results
  - 10.8.1.4 Method Blank Results
  - 10.8.1.5 LCS/LCSD Summary

<sup>1</sup> X – version number

## STANDARD OPERATING PROCEDURES

**DIESEL RANGE ORGANICS**

SOP No.: EMAX-8015D Revision No. 7 Effective Date: 20-Sep-17

---

- 10.8.1.6 MS/MSD Summary
- 10.8.1.7 ICAL Summary
- 10.8.1.8 ICV Summary
- 10.8.1.9 DCC Summary
- 10.8.1.10 Analytical Run Log
- 10.8.1.11 Sample Preparation Log
- 10.8.1.12 Non-Conformance Report (if any)
- 10.8.2 Perform a 100% data review in accordance to EMAX-DM01 and the PSR.
  - 10.8.2.1 If any of the checkpoints below indicate a problem, re-analysis is required.
    - ✓ Check that qualitative identification is done properly.
    - ✓ Check surrogate recoveries against Project Specific Requirements (PSR). In the absence of PSR, default to in-house QC limits.
    - ✓ Check that all samples results are integrated properly and results over calibration range are diluted and re-analyzed within the calibration range.
    - ✓ Where manual integration was performed, check that it was done properly and documentation was retained in accordance to EMAX-DM01 (Section for manual integration).
    - ✓ Check that saturated peak(s) are diluted and quantitated properly.
    - ✓ Check that suspected carry-overs are re-analyzed and results are reported accordingly.
    - ✓ Check that discrete peaks (other than column bleeds) are reported according to project requirement.
  - 10.8.2.2 Review the attached logs that they are properly filled.
  - 10.8.2.3 Check the generated reports against the raw data. Check that the analytical data generated indicating positive results are qualitatively and quantitatively correct.
  - 10.8.2.4 Review the case narrative and check that it accurately describes what transpired in the analytical process. Edit as necessary to reflect essential issues not captured by the case narrative generator program.
- 10.8.3 Submit the analytical folder for secondary review.

## 10.9 Preventive Maintenance

- 10.9.1 Perform daily routine check and record it in the instrument maintenance log. Initial the column corresponding to the date when the instrument was back in control. Refer to Form 8015DFM for daily routine maintenance check points. Routine maintenance ensures that all equipment is operating under optimum conditions, thus reducing the possibility of instrument malfunction that may affect data quality.
- 10.9.2 The table below is a list of preventive maintenance activities that are essential to consider in performing this SOP.

## STANDARD OPERATING PROCEDURES

**DIESEL RANGE ORGANICS**SOP No.: EMAX-8015D Revision No. 7 Effective Date: 20-Sep-17

| <b>Maintenance Activity</b> | <b>Description</b>  | <b>Frequency</b>               |
|-----------------------------|---|--------------------------------|
| Autosampler                 | Inspect and clean syringe. Check autosampler response.  | Daily prior to analysis        |
| Verification                | Check instrument parameters to ensure normal operating conditions.<br>Change liner as necessary.<br>Check instrument performance (e.g., Daily calibration check, instrument blank). | Daily prior to analysis        |
| Documentation               | Record all instrument maintenance performed in the instrument maintenance log.  | Daily prior to analysis        |
| System Cleaning             | Remove dust from fans and vent covers, inspect and clean inlet and detector. Check septa and replace as necessary.  | Every 6 months or as necessary |
| Complete Inspection         | Perform general inspection of the complete system<br>Inspect autosampler cabling and configuration setting. Inspect column, change if necessary (6 mo. or as needed)                | Once a year                    |

10.9.3 Maintain an inventory of instrument parts and supplies for routine maintenance.

**11.0 QUALITY CONTROL****11.1 Analytical Batch QC**

- 11.1.1 Initial Calibration must be established and verified by daily continuing calibration as described in Appendix 1.
- 11.1.2 Analytical batch must consist of a valid ICAL, QC Samples and field samples bracketed with opening and closing DCC every 12-hour analytical sequence, unless other frequency is prescribed by the project.
- 11.1.3 A record must be established that the analytical instrument is free from contamination prior to any analysis. This can be achieved by analyzing a solvent blank and identifying its result as instrument blank.

**11.2 Preparation Batch QC**

- 11.2.1 A preparation batch consists of a MB, LCS, MS/MSD and  $\leq 20$  field samples.
- 11.2.2 For water samples, use organic-free water for MB and LCS.

## STANDARD OPERATING PROCEDURES

**DIESEL RANGE ORGANICS**

SOP No.: EMAX-8015D Revision No. 7 Effective Date: 20-Sep-17

---

- 11.2.3 For soil samples, use organic-free sand for MB and LCS.
- 11.2.4 Prepare, analyze and control QC samples as required by the project. In the absence of PSR, refer to Appendix 1 for Quality Control Procedures.
- 11.2.5 Surrogate standard must be added to all samples, including quality control samples (e.g., method blank, LCS and MS). Check the PSR for QC control Limits. In the absence of PSR default to EMAX-QC Limits.
- 11.2.6 Solvents and reagents must undergo quality control check prior to use. Refer to EMAX-QC01 for details.
- 11.2.7 Properly treat all lab wares used in the sample preparation as specified in EMAX-QC07.

**11.3 Method QC**

- 11.3.1 All analytes reported must have a valid DL, LOD and LOQ as described in EMAX-QA04.
  - 11.3.2 Instrument performance must be checked prior to analysis.
  - 11.3.3 Retention Time Window must be established and updated as prescribed.
  - 11.3.4 All analysts conducting this analysis must demonstrate capability (IDOC/DOC) as described in EMAX-QA05.
- 11.4 Refer to Appendix 1 for all related Quality Control parameters, frequency and acceptance criteria.

**12.0 CORRECTIVE ACTION**

12.1 Corrective action for each Quality Control procedure is summarized in Appendix 1.

**12.2 Calibration**

- 12.2.1 If initial calibration is non-compliant, consider the following suggestions:
  - 12.2.1.1 If RSD > 20%, check each calibration point. If an outlier exists, re-analyze that calibration point.
  - 12.2.1.2 If ICV is not within the expected recovery range, review the chromatogram.
    - Bias low results are indicative of bad injection or standard degradation.
    - Bias high is indicative of inaccurate standard injection of instrument or contamination.
    - Consider preparing a fresh ICV standard and re-analyze the ICV.
  - 12.2.1.3 If problem persists, inform the Supervisor.
- 12.2.2 If the continuing calibration is non-compliant, consider the suggestions described in correcting the ICV. Consider also the following suggestions to correct the problem:
  - Change the liner
  - Clean the injection port
  - Cut or replace the column
  - Clean the detector



## STANDARD OPERATING PROCEDURES

**DIESEL RANGE ORGANICS**SOP No.: EMAX-8015D Revision No. 7 Effective Date: 20-Sep-17

---

- Rule-out leaks by checking all connections
- If continuing calibration is still non-compliant, prepare a new standard and repeat the ICAL

12.2.3 If the instrument blank is non-compliant, consider the following suggestions to correct the problem:

12.2.3.1 Check the solvent blank source, e.g. check if same source was used by a similar analysis on a different instrument to rule out solvent contamination.

12.2.3.2 Bake the GC column for at least 15 min.

12.2.3.3 Re-calculate the data and/or re-analyze the extract, if any of the above checks reveal a problem.

12.2.3.4 If problem persists, inform the Supervisor prior to re-analysis.

### 12.3 Surrogates

12.3.1 If surrogates are non-compliant, and are not due to matrix effects, consider the following suggestions to correct the problem:

12.3.1.1 Check that the surrogate peak is properly integrated.

12.3.1.2 Check for calculation errors and that the concentrations of the surrogate solutions are correct.

- High recoveries may be due to co-eluting matrix interference, examine the sample chromatogram.
- Low recoveries may be due to bad injection during preparation process and/or analytical process.

12.3.1.3 Check instrument performance to determine if it is within acceptable guidelines.

### 12.4 Preparation Batch QC

12.4.1 For insufficient amount of sample(s), inform the supervisor immediately for further action.

12.4.2 if method blank is non-compliant, consider the following suggestion to possibly correct the problem:

- Check the sample results. If sample results are non-detected, you may report the result upon concurring with the PM.
- If sample results are not reportable, determine the source of contamination and correct the problem. Re-analyze method blank and all samples processed with the contaminated blank.

12.4.3 If LCS is non-compliant, consider the following suggestions to possibly correct the problem:

- Check the results, if standard degradation is apparent, prepare a fresh standard and perform the corrective action as described in Appendix 1.
- If the LCS result is bias high, the solvent of the standard may have evaporated. Prepare a fresh standard and perform the corrective action as described in Appendix 1.
- Check instrument performance to determine if it is within acceptable guidelines.
- Re-analyze the extract if any of the above checks a reveal a problem.

## STANDARD OPERATING PROCEDURES

**DIESEL RANGE ORGANICS**

SOP No.: EMAX-8015D Revision No. 7 Effective Date: 20-Sep-17

---

- Otherwise, re-extract all samples associated with the non-compliant LCS with a new set of QC samples.

12.5 A Non-Conformance Report (NCR) is required when any of the following circumstances occur.

- Anomalies, other than specified in Appendix 1, are observed.
- Sample is out of technical holding time.

12.5.1 Refer to EMAX-QA08 for NCR details.

**13.0 POLLUTION PREVENTION**

13.1 Observe all necessary precautions to avoid spillage of solvent that may go to wastewater drains.

13.2 Prepare all standards in fume hoods.

**14.0 WASTE MANAGEMENT**

14.1 No samples may be dumped on the laboratory sink.

14.2 Separate and properly identify all unused expired analytical standards for proper disposal.

14.3 Place all wastes generated during analytical process in properly labeled satellite waste containers for proper collection.

14.4 Dispose all unused samples, expired analytical standards and other waste generated during the analytical process in accordance to EMAX-SM03.

**15.0 SUPPLEMENTARY NOTES****15.1 Definition of Terms**

15.1.1 Analyte – The specific chemicals or components for which a sample is analyzed; may be a group of chemicals that belongs to the same chemical family, and which are analyzed together.

15.1.2 Batch – is a group of samples that are prepared and/or analyzed at the same time using the same lot of reagents.

15.1.2.1 **Preparation Batch** – is composed of one to 20 samples of the same matrix, a method blank, a lab control sample and matrix spike/matrix spike duplicate.

15.1.2.2 **Analytical Batch** – is composed of prepared samples (extracts, digestates, or concentrates), which are analyzed together as a group using an instrument in conformance to the analytical requirement. An analytical batch can include samples originating from various matrices, preparation batches, and can exceed 20 samples.

15.1.3 Detection Limit (DL) – is defined as the smallest analyte concentration that can be demonstrated to be different from zero or a blank concentration at the 99% level of confidence. At the DL, the false positive rate (Type I error) is 1%.

## STANDARD OPERATING PROCEDURES

**DIESEL RANGE ORGANICS**

SOP No.: EMAX-8015D Revision No. 7 Effective Date: 20-Sep-17

---

- 15.1.4 Limit of Detection (LOD) – is defined as the smallest amount or concentration of a substance that must be present in a sample in order to be detected at a high level of confidence (99%). At the LOD, the false negative rate (Type II error) is 1%.
- 15.1.5 Limit of Quantitation (LOQ) – is at the lowest concentration that produces a quantitative result within specified limits of precision and bias. For DoD projects, the LOQ shall be set at or above the concentration of the lowest initial calibration standard.
- 15.1.6 Safety Data Sheet (SDS) – is a written information concerning a chemical physical properties, toxicity, health hazards, fire hazard and reactivity data including storage, spill and handling precautions.
- 15.1.7 Calibration – is a determinant measured from a standard to obtain the correct value of an instrument output.
- 15.1.8 Calibration Blank – is a target-analyte-free solvent subjected to the entire analytical process to establish zero baseline or background value.
- 15.1.9 Instrument Method – is a file generated to contain the instrument calibration and instrument parameter settings for a particular analysis.
- 15.1.10 Method Blank – is a target-analyte-free sample subjected to the entire sample preparation and/or analytical to monitor contamination.
- 15.1.11 Lab Control Sample (LCS) – is a target-analyte-free sample spiked with a verified known amount of target analyte(s) or a reference material with a certified known value subjected to the entire sample preparation and/or analytical process. LCS is analyzed to monitor the accuracy of the analytical system.
- 15.1.12 Lab Control Sample Duplicate (LCSD) – is a replicate of LCS analyzed to monitor precision in the absence of MS/MSD sample.
- 15.1.13 Sample – is a specimen received in the laboratory bearing a sample label traceable to the accompanying COC. Samples collected in different containers having the same field sample ID are considered the same and therefore labeled with the same lab sample ID unless otherwise specified by the project.
- 15.1.14 Sample Duplicate – is a replicate of a sub-sample taken from one sample, prepared and analyzed within the same preparation batch.
- 15.1.15 Sub-sample – is an aliquot taken from a sample for analysis. Each sub-sample is uniquely identified by the sample preparation ID.
- 15.1.16 Matrix – is a component or form of a sample.
- 15.1.17 Matrix Spike (MS) – is a sample spiked with a verified known amount of target analyte(s) subjected to the entire sample preparation and/or analytical process. MS is analyzed to monitor matrix effect on a method's recovery efficiency.
- 15.1.18 Matrix Spike Duplicate (MSD) – is a replicate of MS analyzed to monitor precision or recovery.
- 15.1.19 Surrogate – are compounds added to every blank, sample, matrix spike, matrix spike duplicate and standard; used to evaluate analytical efficiency by measuring recovery. Compounds not expected to be detected in environmental media.

## STANDARD OPERATING PROCEDURES

**DIESEL RANGE ORGANICS**

SOP No.: EMAX-8015D Revision No. 7 Effective Date: 20-Sep-17

---

15.1.20 Reagent Water – is purified water free from any target analyte or any other substance that may interfere with the analytical process.

15.2 **Application of EMAX QC Procedures**

15.2.1 The procedures and QC criteria summarized in this SOP applies to all projects when performing Diesel Range Organics Analysis by GC. In instances where there is a project or program QAPP, the requirements given in the project takes precedence over this SOP.

15.3 **Department of Defense (DoD) Projects**

15.3.1 Samples from DoD sponsored projects follows the Quality Assurance Project Plan (QAPP), Statement of Work (SOW) and/or client's quality control directive. In the absence of QAPP, the DoD Quality Systems Manual (QSM), latest update, is applied.

15.4 **Department of Energy (DoE) Projects**

15.4.1 Samples from DoE sponsored projects follows the Quality Assurance Project Plan (QAPP), Statement of Work (SOW) and/or client's quality control directive. In the absence of QAPP, the DoE Quality Systems for Analytical Services (QSAS), latest update, is applied.

**16.0 REFERENCES**

- 16.1 US EPA Method 8015C, Revision 3, February 2007
- 16.2 US EPA Method 8015D, Revision 4, June 2003
- 16.3 US EPA Method 8015B, Revision 2, December 1996
- 16.4 US EPA Method 8000B, Revision 2, December 1996
- 16.5 EMAX Quality Systems Manual, as updated

**17.0 APPENDICES**

17.1 **Tables**

- 17.1.1 Table 1 Established DL, LOD and LOQ

17.2 **Figures**

- 17.2.1 Figure 1 Peak Evaluation Technique
- 17.2.2 Figure 2A Typical DRO Chromatogram
- 17.2.3 Figure 2B Typical JP5 & Motor Oil Chromatogram
- 17.2.4 Figure 2C Typical n-Alkane Chromatogram
- 17.2.5 Figure 3A Typical Diesel Initial Calibration Summary
- 17.2.6 Figure 3B Typical JP5 & Motor Oil Initial Calibration Summary
- 17.2.7 Figure 4A Typical Diesel Continuing Calibration Summary
- 17.2.8 Figure 4B Typical JP5 & Motor Oil Continuing Calibration Summary

## STANDARD OPERATING PROCEDURES

**DIESEL RANGE ORGANICS**

SOP No.: EMAX-8015D Revision No. 7 Effective Date: 20-Sep-17

---

- 17.2.9 Figure 5 Typical Raw Data
- 17.2.10 Figure 6 Typical Sample Result Summary
- 17.2.11 Figure 7 Typical LCS/LCSD Summary
- 17.2.12 Figure 8 Typical MS/MSD Summary
- 17.2.13 Figure 9 Typical Case Narrative
- 17.3 **Appendices**
  - 17.3.1 Appendix 1 Summary of Quality Control Procedures
  - 17.3.2 Appendix 2 Demonstration of Capability
- 17.4 **Forms**
  - 17.4.1 8015DFS Sample Preparation Log
  - 17.4.2 8015DFA Analytical Run Log
  - 17.4.3 8015DFM Instrument Maintenance Log

**Table 1: ESTABLISHED DL, LOD AND LOQ**

| Parameter        | Water<br>(mg/L) |       |      | Soil<br>(mg/Kg) |     |     |
|------------------|-----------------|-------|------|-----------------|-----|-----|
|                  | DL              | LOD   | LOQ  | DL              | LOD | LOQ |
| Diesel (Total)   | 0.025           | 0.05  | 0.1  | 2.5             | 5   | 10  |
| Diesel (C10-C24) | 0.025           | 0.05  | 0.1  | 2.5             | 5   | 10  |
| Diesel (C10-C25) | 0.025           | 0.05  | 0.1  | 2.5             | 5   | 10  |
| Diesel (C10-C28) | 0.025           | 0.05  | 0.1  | 2.5             | 5   | 10  |
| JP5              | 0.025           | 0.05  | 0.1  | 2.8             | 5   | 10  |
| 5W30             | 0.025           | 0.05  | 0.1  | 2.5             | 5   | 10  |
| 10W30            | 0.025           | 0.05  | 0.1  | -               | -   | -   |
| Bromobenzene     | 0.05            | 0.1   | 0.2  | 5.0             | 10  | 20  |
| Hexacosane       | 0.0125          | 0.025 | 0.05 | 1.25            | 2.5 | 5   |

**Figure 1:**

**PEAK EVALUATION TECHNIQUE**

---

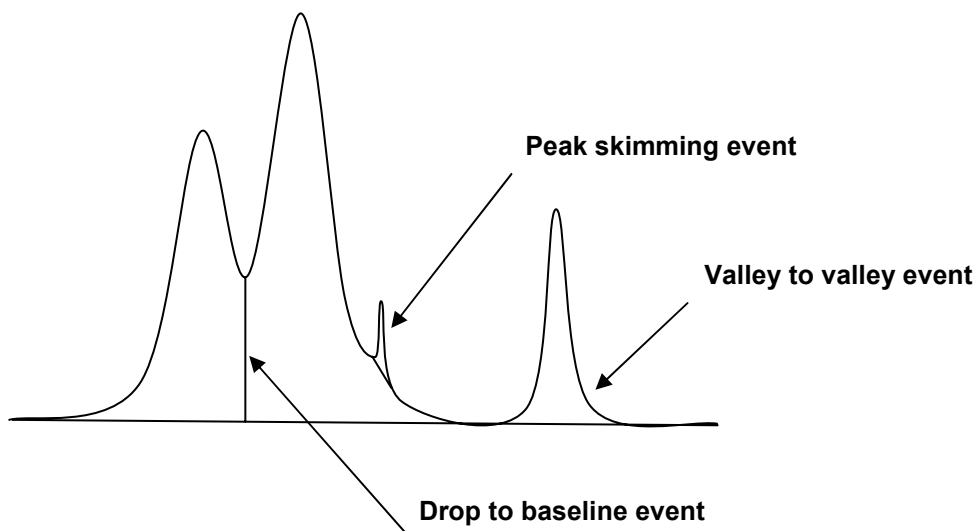

**Figure 2A: TYPICAL DRO CHROMATOGRAM**

METHOD 8015 by GC/FID  
 EMAX Laboratories, Inc.

Inst. Name: : D5 (Offline)  
 File : D:\Projects\EZC331\Data\LC28\LC28011.dat  
 Method : D:\Projects\EZC331\Method\2017 METHODS\DSD5C28.met  
 Sequence: : D:\Projects\EZC331\Sequence\LC28.seq  
 Sample ID : IDSD5C28001 DSL 500/80/20PPM  
 Acquired : 03/29/17 21:11:22  
 Printed : 06/19/17 15:17:28  
 User : CZhao

| FID Results<br>Name | Retention Time | Area     | Average RF  | ESTD conc.<br>[ ppm ] |
|---------------------|----------------|----------|-------------|-----------------------|
| BROMOBENZENE        | 1.745          | 1550952  | 19006.39231 | 81.602                |
| HEXACOSANE          | 4.911          | 496166   | 22321.13616 | 22.229                |
| DIESEL(TOTAL)       |                | 14542060 | 26778.65690 | 543.047               |
| DIESEL(C10-C24)     |                | 13913905 | 25127.20014 | 553.739               |
| DIESEL(C10-C28)     |                | 14024454 | 25377.61786 | 552.631               |
| DIESEL(C10-C25)     |                | 13958042 | 25248.85905 | 552.819               |
| DIESEL(C9-C24)      |                | 14132869 | 26015.56633 | 543.247               |
| DIESEL(C9-C25)      |                | 14177006 | 26137.22524 | 542.407               |
| DIESEL(C10-C36)     |                | 14134943 | 25410.79243 | 556.257               |
| DIESEL(C10-C40)     |                | 14134943 | 25410.79243 | 556.257               |

|        |  |           |  |          |
|--------|--|-----------|--|----------|
| Totals |  | 115065340 |  | 4504.233 |
|--------|--|-----------|--|----------|

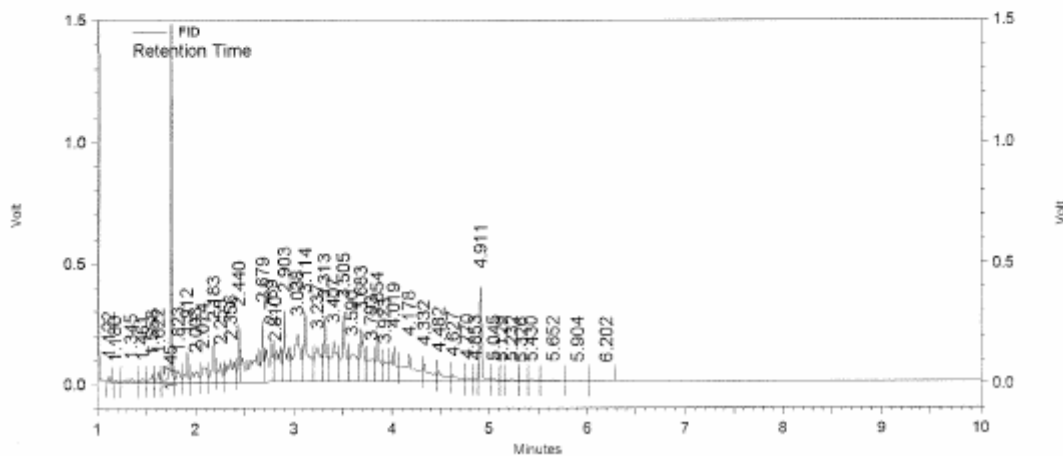

Software Version: Version 3.3.1

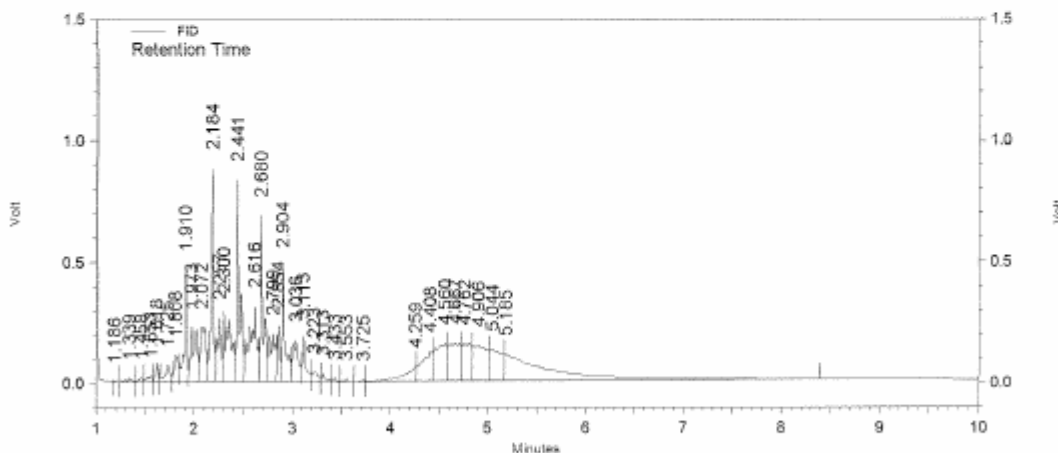

**Figure 2B: TYPICAL JP5 & MOTOR OIL CHROMATOGRAM**

METHOD 8015 by GC/FID  
 EMAX Laboratories, Inc.

Inst. Name: : D5 (Offline)  
 File : D:\Projects\EZC331\Data\LC28\LC28020.dat  
 Method : D:\Projects\EZC331\Method\2017 METHODS\DSD5C28.met  
 Sequence: : D:\Projects\EZC331\Sequence\LC28.seq  
 Sample ID : IDSD5C28003 JP5/5W30 500/500PPM  
 Acquired : 03/29/17 23:42:06  
 Printed : 06/19/17 15:18:11  
 User : CZhao

| FID Results    |                |          |             |                       |
|----------------|----------------|----------|-------------|-----------------------|
| Name           | Retention Time | Area     | Average RF  | ESTD conc.<br>[ ppm ] |
| JP5(C8-C18)    |                | 14662745 | 33414.61889 | 438.812               |
| M.OIL(C18-C36) |                | 10941015 | 23856.69344 | 458.614               |
| M.OIL(C24-C36) |                | 8321980  | 20641.25678 | 403.172               |
| M.OIL(C24-C40) |                | 8321980  | 20641.25678 | 403.172               |
| Totals         |                | 42247720 |             | 1703.771              |



**Figure 2C: TYPICAL n-ALKANE CHROMATOGRAM**

METHOD 8015 by GC/FID  
 EMAX Laboratories, Inc.

Inst. Name: : D5 (Offline)  
 File : D:\Projects\EZC331\Data\LC28\LC28003.dat  
 Method : D:\Projects\EZC331\Method\2017 METHODS\DSD5C28.met  
 Sequence: : D:\Projects\EZC331\Sequence\LC28.seq  
 Sample ID : DRO-01  
 Acquired : 03/29/17 18:57:32  
 Printed : 06/19/17 15:18:26  
 User : CZhao

| FID Results Name | Retention Time | Area     | Average RF  | ESTD conc. [ ppm ] |
|------------------|----------------|----------|-------------|--------------------|
| BROMOBENZENE     |                |          |             | 0.000 BDL          |
| HEXACOSANE       | 4.921          | 424588   | 22321.13616 | 19.022             |
| DIESEL(TOTAL)    |                | 15467068 | 26778.65690 | 577.589            |
| DIESEL(C10-C24)  |                | 9016646  | 25127.20014 | 358.840            |
| DIESEL(C10-C28)  |                | 10257523 | 25377.61786 | 404.196            |
| DIESEL(C10-C25)  |                | 9016646  | 25248.85905 | 357.111            |
| DIESEL(C9-C24)   |                | 9020885  | 26015.56633 | 346.750            |
| DIESEL(C9-C25)   |                | 9020885  | 26137.22524 | 345.136            |
| DIESEL(C10-C36)  |                | 12767078 | 25410.79243 | 502.427            |
| DIESEL(C10-C40)  |                | 13988721 | 25410.79243 | 550.503            |

| Totals | Area     | ESTD conc. |
|--------|----------|------------|
|        | 88980040 | 3461.573   |

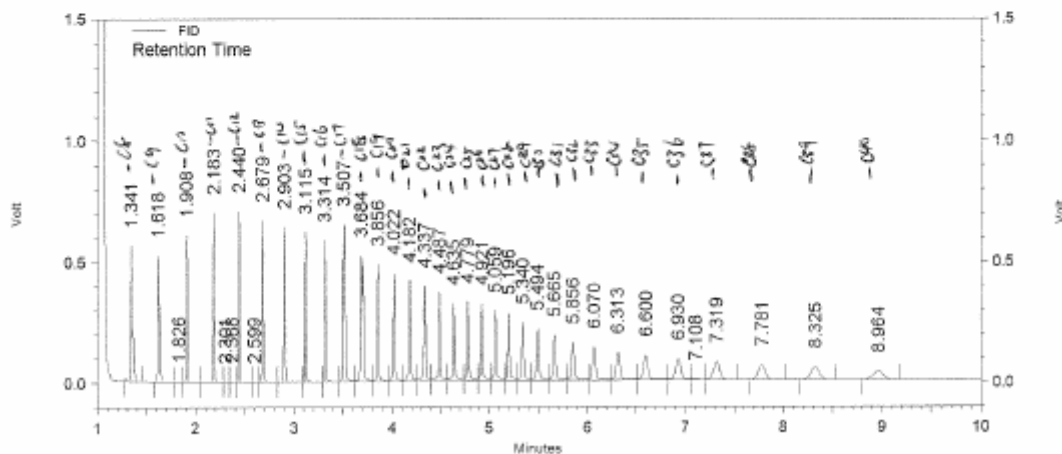

Software Version: Version 3.3.1

**Figure 3A: TYPICAL DIESEL INITIAL CALIBRATION SUMMARY**

INITIAL CALIBRATION  
 METHOD M8015

Lab Name : EMAX Inc  
 Instrument ID : D5  
 GC Column : HP5  
 Column size ID : 30MX0.32MM 0.25UM  
 LFID & Datetime: LC28004A 03/29/17 19:14  
 LFID & Datetime: LC28005A 03/29/17 19:30  
 LFID & Datetime: LC28006A 03/29/17 19:47  
 LFID & Datetime: LC28007A 03/29/17 20:04  
 LFID & Datetime: LC28008A 03/29/17 20:21  
 LFID & Datetime: LC28009A 03/29/17 20:37  
 LFID & Datetime: LC28010A 03/29/17 20:54  
 CONC UNIT: ppm

| COMPOUND        | CONC<br>X | CALIBRATION FACTORS |       |        |        |         |         | (AREA)/UNIT |         | MEAN | %RSD |
|-----------------|-----------|---------------------|-------|--------|--------|---------|---------|-------------|---------|------|------|
|                 |           | 1.00X               | 2.00X | 10.00X | 20.00X | 100.00X | 300.00X | 600.00X     |         |      |      |
| DIESEL(TOTAL)   | 5.00      | 24541               | 22722 | 22488  | 25778  | 30053   | 30402   | 31466       | 26778.7 | 14.2 |      |
| DIESEL(C10-C24) | 5.00      | 22416               | 21360 | 21504  | 24511  | 28250   | 28432   | 29417       | 25127.2 | 14.0 |      |
| DIESEL(C10-C28) | 5.00      | 23159               | 21722 | 21578  | 24538  | 28379   | 28631   | 29636       | 25377.6 | 13.6 |      |
| DIESEL(C10-C25) | 5.00      | 22753               | 21501 | 21542  | 24521  | 28322   | 28552   | 29550       | 25248.9 | 13.9 |      |
| DIESEL(C9-C24)  | 5.00      | 23365               | 22195 | 22149  | 25234  | 29254   | 29449   | 30463       | 26015.6 | 14.0 |      |
| DIESEL(C9-C25)  | 5.00      | 23702               | 22336 | 22187  | 25244  | 29327   | 29569   | 30596       | 26137.2 | 13.8 |      |
| DIESEL(C10-C36) | 5.00      | 23159               | 21722 | 21578  | 24538  | 28415   | 28726   | 29737       | 25410.8 | 13.7 |      |
| DIESEL(C10-C40) | 5.00      | 23159               | 21722 | 21578  | 24538  | 28415   | 28726   | 29737       | 25410.8 | 13.7 |      |
| SURROGATE       | X         | 0.00X               | 1.00X | 2.00X  | 3.00X  | 4.00X   | 5.00X   | 11.00X      | MEAN    | %RSD |      |
| BROMOBENZENE    | 20.00     | 0                   | 18130 | 17939  | 18670  | 20717   | 19114   | 19469       | 19006.4 | 5.4  |      |
| HEXACOSANE      | 5.00      | 0                   | 21767 | 20750  | 22349  | 24398   | 21621   | 23042       | 22321.1 | 5.7  |      |

DSD5C28.MET

**Figure 3B: TYPICAL JP5 & MOTOR OIL INITIAL CALIBRATION SUMMARY**

INITIAL CALIBRATION  
 METHOD M8015

Lab Name : EMAX Inc  
 Instrument ID : D5  
 GC Column : HP5  
 Column size ID : 30MX0.32MM 0.25UM  
 LFID & Datetime: LC28013A 03/29/17 21:44  
 LFID & Datetime: LC28014A 03/29/17 22:01  
 LFID & Datetime: LC28015A 03/29/17 22:18  
 LFID & Datetime: LC28016A 03/29/17 22:35  
 LFID & Datetime: LC28017A 03/29/17 22:51  
 LFID & Datetime: LC28018A 03/29/17 23:08  
 CONC UNIT: ppm

| COMPOUND       | CONC<br>X | CALIBRATION FACTORS |        |        |         |         | (AREA)/UNIT |         | MEAN | %RSD |
|----------------|-----------|---------------------|--------|--------|---------|---------|-------------|---------|------|------|
|                |           | 2.00X               | 10.00X | 20.00X | 100.00X | 200.00X | 300.00X     |         |      |      |
| JP5(C8-C18)    | 5.00      | 36729               | 31862  | 32627  | 33929   | 33996   | 31345       | 33414.6 | 5.8  |      |
| M.OIL(C18-C36) | 5.00      | 26134               | 24905  | 22519  | 23869   | 23691   | 22023       | 23856.7 | 6.3  |      |
| M.OIL(C24-C36) | 5.00      | 23315               | 21831  | 19343  | 20291   | 20233   | 18835       | 20641.3 | 8.0  |      |
| M.OIL(C24-C40) | 5.00      | 23315               | 21831  | 19343  | 20291   | 20233   | 18835       | 20641.3 | 8.0  |      |

DSD5C28.MET

**Figure 4A: TYPICAL DIESEL CONTINUING CALIBRATION SUMMARY**

CONTINUE CALIBRATION  
 METHOD M8015

Lab Name : EMAX Inc  
 Instrument ID : D5  
 GC Column : HP5  
 Column size ID : 30MX0.32MM 0.25UM  
 Mid Conc Init LFID & Datetime: LC28007A 03/29/2017 20:04  
 Conc Cont LFID & Datetime: LC28046A 03/30/2017 06:59  
 CONC UNIT : ppm

| COMPOUND        | RT MINUTES | RT WINDOW |       | TRUE CONC | AVERAGE CF | RESULT   |        |    | QL | %D LIMITS |
|-----------------|------------|-----------|-------|-----------|------------|----------|--------|----|----|-----------|
|                 |            | FROM      | TO    |           |            | AREA     | CONC   | %D |    |           |
| DIESEL(TOTAL)   | NA         | NA        | NA    | 500.0     | 26778.7    | 14051854 | 524.74 | 5  |    | 20        |
| DIESEL(C10-C24) | NA         | NA        | NA    | 500.0     | 25127.2    | 13195089 | 525.13 | 5  |    | 20        |
| DIESEL(C10-C28) | NA         | NA        | NA    | 500.0     | 25377.6    | 13300006 | 524.08 | 5  |    | 20        |
| DIESEL(C10-C25) | NA         | NA        | NA    | 500.0     | 25248.9    | 13268804 | 525.52 | 5  |    | 20        |
| DIESEL(C9-C24)  | NA         | NA        | NA    | 500.0     | 26015.6    | 13618860 | 523.49 | 5  |    | 20        |
| DIESEL(C9-C25)  | NA         | NA        | NA    | 500.0     | 26137.2    | 13692575 | 523.87 | 5  |    | 20        |
| DIESEL(C10-C36) | NA         | NA        | NA    | 500.0     | 25410.8    | 13312960 | 523.91 | 5  |    | 20        |
| DIESEL(C10-C40) | NA         | NA        | NA    | 500.0     | 25410.8    | 13312960 | 523.91 | 5  |    | 20        |
| SURROGATE       | MINUTES    | FROM      | TO    | TRUECONC  | CF         | AREA     | CONC   | %D | QL | LIMITS    |
| BROMOBENZENE    | 1.745      | 1.735     | 1.755 | 80.0      | 19006.4    | 1627262  | 85.62  | 7  |    | 20        |
| HEXACOSANE      | 4.963      | 4.769     | 5.157 | 20.0      | 22321.1    | 454848   | 20.38  | 2  |    | 20        |

**Figure 4B: TYPICAL JP5 & MOTOR OIL CONTINUING CALIBRATION SUMMARY**

CONTINUE CALIBRATION  
 METHOD M8015

Lab Name : EMAX Inc  
 Instrument ID : D5  
 GC Column : HP5  
 Column size ID : 30MX0.32MM 0.25UM  
 Mid Conc Init LFID & Datetime: LC28016A 03/29/2017 22:35  
 Conc Cont LFID & Datetime: LC28047A 03/30/2017 07:16  
 CONC UNIT : ppm

| COMPOUND       | RT MINUTES | RT WINDOW |    | TRUE CONC | AVERAGE CF | RESULT   |        |    | QL | %D LIMITS |
|----------------|------------|-----------|----|-----------|------------|----------|--------|----|----|-----------|
|                |            | FROM      | TO |           |            | AREA     | CONC   | %D |    |           |
| JP5(C8-C18)    | NA         | NA        | NA | 500.0     | 33414.6    | 15383110 | 460.37 | -8 |    | 20        |
| M.OIL(C18-C36) | NA         | NA        | NA | 500.0     | 23856.7    | 10916024 | 457.57 | -8 |    | 20        |
| M.OIL(C24-C36) | NA         | NA        | NA | 500.0     | 20641.3    | 9346513  | 452.81 | -9 |    | 20        |
| M.OIL(C24-C40) | NA         | NA        | NA | 500.0     | 20641.3    | 9346513  | 452.81 | -9 |    | 20        |

**Figure 5: TYPICAL RAW DATA**

Page 1 of 1

METHOD 8015 by GC/FID  
 EMAX Laboratories, Inc.

Inst. Name: : D5 (Offline)  
 File : D:\Projects\EZC331\Data\LC28\LC28043.dat  
 Method : D:\Projects\EZC331\Method\2017 METHODS\DSD5C28M.met  
 Sequence: : D:\Projects\EZC331\Sequence\LC28.seq  
 Sample ID : 17C173-03  
 Acquired : 03/30/17 06:09:05  
 Printed : 06/30/17 11:17:41  
 User : CZhao

**FID Results**

| Name            | Retention Time | Area    | Average RF  | ESTD conc.<br>[ ppm ] |
|-----------------|----------------|---------|-------------|-----------------------|
| BROMOBENZENE    | 1.743          | 1461045 | 19006.39231 | 76.871                |
| HEXACOSANE      | 4.968          | 493024  | 22321.13616 | 22.088                |
| DIESEL(TOTAL)   |                | 1113398 | 26778.65690 | 41.578                |
| DIESEL(C13-C22) |                | 620701  | 25127.20014 | 24.702                |
| M.OIL(C23-C32)  |                | 178785  | 20641.25678 | 8.662                 |

|        |  |         |  |         |
|--------|--|---------|--|---------|
| Totals |  | 3866953 |  | 173.901 |
|--------|--|---------|--|---------|

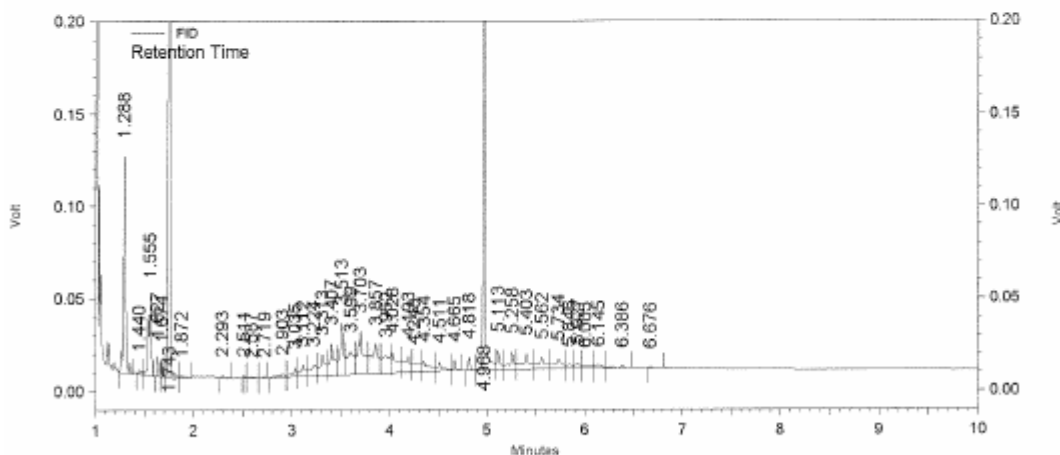

Software Version: Version 3.3.1

**Figure 6: TYPICAL SAMPLE RESULT SUMMARY**

METHOD 3550B/8015B  
 PETROLEUM HYDROCARBONS BY EXTRACTION

```

=====
Client       : XYZ, INC.                Date Collected: 03/23/17
Project      : CLEAN PROJECT           Date Received: 03/25/17
Batch No.    : YYMXXX                  Date Extracted: 03/28/17 10:02
Sample ID    : ABCD-03                 Date Analyzed: 03/30/17 06:09
Lab Samp ID  : MXXX-03                 Dilution Factor: 1
Lab File ID  : LC28043A                Matrix          : SOIL
Ext Btch ID  : DSC041S                 % Moisture      : 3.3
Calib. Ref.  : LC28034A                Instrument ID   : D5
=====
  
```

| PARAMETERS | RESULTS<br>(mg/kg) | LOQ<br>(mg/kg) | DL<br>(mg/kg) | LOD<br>(mg/kg) |
|------------|--------------------|----------------|---------------|----------------|
| DIESEL     | 26                 | 10             | 2.6           | 5.2            |
| MOTOR OIL  | 9.0J               | 21             | 2.6           | 5.2            |

| SURROGATE PARAMETERS | RESULTS | SPK_AMT | % RECOVERY | QC LIMIT |
|----------------------|---------|---------|------------|----------|
| BROMOBENZENE         | 79.5    | 103.4   | 76.9       | 50-130   |
| HEXACOSANE           | 22.8    | 25.85   | 88.4       | 40-160   |

| Parameter | H-C Range" |
|-----------|------------|
| Diesel    | C13-C22    |
| Motor Oil | C23-C32    |

Figure 7:

TYPICAL LCS/LCSD SUMMARY

EMAX QUALITY CONTROL DATA  
 LCS/LCD ANALYSIS

CLIENT: XYZ, INC.  
 PROJECT: CLEAN PROJECT  
 BATCH NO.: YYMXXX  
 METHOD: METHOD 3550B/8015B

=====

MATRIX: SOIL % MOISTURE: NA  
 DILUTION FACTOR: 1 1 1  
 SAMPLE ID: MBLK1S  
 LAB SAMP ID: DSC041SB DSC041SL DSC041SC  
 LAB FILE ID: LC28036A LC28037A LC28038A  
 DATE EXTRACTED: 03/28/1710:02 03/28/1710:02 03/28/1710:02 DATE COLLECTED: NA  
 DATE ANALYZED: 03/30/1704:11 03/30/1704:27 03/30/1704:44 DATE RECEIVED: 03/28/17  
 PREP. BATCH: DSC041S DSC041S DSC041S  
 CALIB. REF: LC28034A LC28034A LC28034A

ACCESSION:

| PARAMETER | BLNK RSLT<br>(mg/kg) | SPIKE AMT<br>(mg/kg) | BS RSLT<br>(mg/kg) | BS<br>% REC | SPIKE AMT<br>(mg/kg) | BSD RSLT<br>(mg/kg) | BSD<br>% REC | RPD<br>(%) | QC LIMIT<br>(%) | MAX RPD<br>(%) |
|-----------|----------------------|----------------------|--------------------|-------------|----------------------|---------------------|--------------|------------|-----------------|----------------|
| Diesel    | ND                   | 500                  | 467                | 93          | 500                  | 465                 | 93           | 1          | 38-132          | 30             |

=====

| SURROGATE PARAMETER | SPIKE AMT<br>(mg/kg) | BS RSLT<br>(mg/kg) | BS<br>% REC | SPIKE AMT<br>(mg/kg) | BSD RSLT<br>(mg/kg) | BSD<br>% REC | QC LIMIT<br>(%) |
|---------------------|----------------------|--------------------|-------------|----------------------|---------------------|--------------|-----------------|
| Bromobenzene        | 100                  | 85.0               | 85          | 100                  | 83.1                | 83           | 50-130          |
| Hexacosane          | 25.0                 | 23.4               | 93          | 25.0                 | 22.6                | 90           | 60-130          |



Figure 8:

TYPICAL MS/MSD SUMMARY

EMAX QUALITY CONTROL DATA  
 MS/MSD ANALYSIS

CLIENT: XYZ, INC.  
 PROJECT: CLEAN PROJECT  
 BATCH NO.: YYMXXX  
 METHOD: METHOD 3550B/8015B

=====

MATRIX: SOIL % MOISTURE: 18.2  
 DILUTION FACTOR: 1 1 1  
 SAMPLE ID: ABCD-01  
 LAB SAMP ID: MXXX-12 MXXX-12M MXXX-12S  
 LAB FILE ID: LC28049A LC28050A LC28051A  
 DATE EXTRACTED: 03/28/1710:02 03/28/1710:02 03/28/1710:02 DATE COLLECTED: 03/24/17  
 DATE ANALYZED: 03/30/1707:50 03/30/1708:07 03/30/1708:24 DATE RECEIVED: 03/25/17  
 PREP. BATCH: DSC041S DSC041S DSC041S  
 CALIB. REF: LC28046A LC28046A LC28046A

ACCESSION:

| PARAMETER | SMPL RSLT<br>(mg/kg) | SPIKE AMT<br>(mg/kg) | MS RSLT<br>(mg/kg) | MS<br>% REC | SPIKE AMT<br>(mg/kg) | MSD RSLT<br>(mg/kg) | MSD<br>% REC | RPD<br>( % ) | QC LIMIT<br>( % ) | MAX RPD<br>( % ) |
|-----------|----------------------|----------------------|--------------------|-------------|----------------------|---------------------|--------------|--------------|-------------------|------------------|
| Diesel    | ND                   | 611                  | 472                | 77          | 611                  | 542                 | 89           | 14           | 38-132            | 30               |

=====

| SURROGATE PARAMETER | SPIKE AMT<br>(mg/kg) | MS RSLT<br>(mg/kg) | MS<br>% REC | SPIKE AMT<br>(mg/kg) | MSD RSLT<br>(mg/kg) | MSD<br>% REC | QC LIMIT<br>( % ) |
|---------------------|----------------------|--------------------|-------------|----------------------|---------------------|--------------|-------------------|
| Bromobenzene        | 122                  | 95.8               | 78          | 122                  | 99.4                | 81           | 50-130            |
| Hexacosane          | 30.6                 | 27.1               | 89          | 30.6                 | 28.4                | 93           | 40-160            |

**Figure 9: TYPICAL CASE NARRATIVE**

---

CASE NARRATIVE

Client : XYZ, INC.

Project: CLEAN PROJECT

SDG : YYMXXX

METHOD 3550B/8015B  
PETROLEUM HYDROCARBONS BY EXTRACTION

A total of eight (8) soil samples were received on 03/25/17 to be analyzed for Petroleum Hydrocarbons by Extraction in accordance with Method 3550B/8015B and project specific requirements.

Holding Time

Samples were analyzed within the prescribed holding time.

Calibration

Multi-calibration points were generated to establish initial calibration (ICAL). ICAL was verified using a secondary source (ICV). Continuing calibration (CCV) verifications were carried out on a frequency specified by the project. All calibration requirements were within acceptance criteria. Refer to calibration summary forms of ICAL, ICV and CCV for details.

Method Blank

Method blank was prepared and analyzed at the frequency required by the project. For this SDG, one (1) method blank was analyzed. DSC041SB - result was compliant to project requirement. Refer to sample result summary form for details.

Lab Control Sample

Lab control sample was prepared and analyzed at a frequency required by the project. For this SDG, one (1) set of LCS/LCD was analyzed. DSC041SL/DSC041SC were within LCS limits. Refer to LCS summary form for details.

Matrix QC Sample

Matrix spike sample was prepared and analyzed at a frequency required by the project. For this SDG, one (1) set of MS/MSD was analyzed. Diesel was within MS QC limits in MXXX-12M/S. Refer to Matrix QC summary form for details.

Surrogate

Surrogates were added on QC and field samples. All surrogate recoveries were within QC limits. Refer to sample result summary forms for details.

Sample Analysis

Samples were analyzed according to prescribed analytical procedures. Results were evaluated in accordance to project requirements. For this SDG, all quality control requirements were met.

Samples MXXX-02, -03 and -05 displayed heavier fuel pattern.

**Appendix 1:**

**SUMMARY OF QUALITY CONTROL PROCEDURES**

| QC Procedure   | Frequency   | Acceptance Criteria                                  | Corrective Action   | 1 <sup>st</sup><br>Rvw | 2 <sup>nd</sup><br>Rvw |
|--|---|--|---|------------------------|------------------------|
| Minimum five-point initial calibration               | Initially; as needed  | Linear - mean RSD ≤ 20%                              | Correct the problem then repeat initial calibration   |                        |                        |
| Second-source calibration verification               | After initial calibration   | Within ± 25% of expected value                       | Correct the problem then repeat initial calibration   |                        |                        |
| Initial calibration verification                     | Daily, before sample analysis                                       | Within ± 20% of expected value                       | Correct the problem then repeat initial calibration   |                        |                        |
| Calibration verification                             | Every 12 hours of analysis time and at the end of analysis sequence | Within ± 20% of expected value                       | Correct the problem then repeat initial calibration verification and re-analyze all samples since last successful calibration verification  |                        |                        |
| Method Blank (MB)                                    | One MB per preparation batch  | No analyte detected > ½ LOQ                          | Re-prep and re-analyze method blank and all samples processed with the contaminated blank   |                        |                        |
| Lab Control Sample (LCS)                             | One LCS per preparation batch                                       | Within EMAX QC Limits                                | Re-prep and re-analyze the LCS and all associated samples   |                        |                        |
| Surrogate spike                                      | Every sample, spiked sample, standard, and method blank             | Within EMAX QC Limits                                | Correct the problem then re-extract and re-analyze sample   |                        |                        |
| Matrix Spike/Matrix Spike Duplicate (MS/MSD)         | One MS/MSD per every 20 project samples per matrix                  | Refer to EMAX QC Limits                              | None  |                        |                        |
| Chromatogram   | All sample results  | Within calibration range<br><br>NO SATURATED PEAK(s) | Dilute and re-analyze all samples over the calibration range<br><br>Diluted and re-analyzed all samples demonstrating saturated peak(s) even if the total integrated peaks do not exceed the calibration range. |                        |                        |
| <b>Comments:</b> Refer to PSR for flagging criteria. |   |  | Reviewed By:  |                        |                        |
|  |   |  | Date:   |                        |                        |

Appendix 2:

DEMONSTRATION OF CAPABILITY

DEMONSTRATION OF CAPABILITY  
DIESEL  
METHOD: EPA 8015B

MATRIX: SOIL

Analytical SOP: EMAX-8015D Rev. 6  
 Sample Preparation SOP: EMAX-3550 Rev. 5  
 Conc Unit: mg/Kg  
 Sample Amount (g): 10  
 Volume Extracted (ml): 10  
 Date Extracted: 01/16/17  
 Extracted by: J. Villena  
 Date Analyzed: 01/18/17  
 Analyzed by: W. Zhao

| PARAMETER       | LA18007A | LA18008A | LA18009A | LA18010A | TV  | Ave. Conc | Ave. %Rec | SD    | RSD | QC Criteria | Comments |
|-----------------|----------|----------|----------|----------|-----|-----------|-----------|-------|-----|-------------|----------|
|                 | DSA009SL | DSA009SC | DSA009SX | DSA009SY |     |           |           |       |     |             |          |
| DIESEL(TOTAL)   | 507      | 503      | 485      | 485      | 500 | 495       | 99        | 11.8  | 2   | 20 - 160    | Passed   |
| DIESEL(C10-C24) | 502      | 502      | 484      | 485      | 500 | 493       | 99        | 10.5  | 2   | 20 - 160    | Passed   |
| DIESEL(C10-C28) | 503      | 503      | 484      | 485      | 500 | 494       | 99        | 10.5  | 2   | 20 - 160    | Passed   |
| DIESEL(C10-C25) | 503.7    | 503.4    | 485.0    | 485.5    | 500 | 494.4     | 99        | 10.5  | 2   | 20 - 160    | Passed   |
| BROMOBENZENE    | 86       | 88       | 86       | 89       | 100 | 87        | 87        | 1.4   | 2   | 60 - 130    | Passed   |
| HEXACOSANE      | 21.5     | 22.3     | 21.7     | 22.8     | 25  | 22.1      | 88        | 0.6   | 3   | 60 - 140    | Passed   |
| PARAMETER       | LA18011A | LA18012A | LA18013A | LA18014A | TV  | Ave. Conc | Ave. %Rec | SD    | RSD | QC Criteria | Comments |
|                 | J5A009SL | J5A009SC | J5A009SX | J5A009SY |     |           |           |       |     |             |          |
| JP5             | 444.63   | 454.83   | 446.34   | 477.02   | 500 | 455.70    | 91        | 14.90 | 3   | 30 - 160    | Passed   |
| 5W30            | 436.98   | 452.77   | 437.68   | 451.82   | 500 | 444.81    | 89        | 8.66  | 2   | 30 - 160    | Passed   |











## STANDARD OPERATING PROCEDURES

**GASOLINE RANGE ORGANICS**

SOP No.: EMAX-8015G Revision No. 5 Effective Date: 24-Jan-14

Prepared By: Lucita Arzadon *L.A. Arzadon* Date: 01-24-14

Approved By: Kenette Pimentel *K. Pimentel* Date: 01-24-14  
QA Manager

Approved By: Caspar Pang *C. Pang* Date: 01-24-14  
Laboratory Director

Control Number: 8015G-05-

**1.0 SCOPE AND APPLICATION**

- 1.1. This method is applicable for analyzing purgeable petroleum hydrocarbons bracketed by the range of alkanes from C<sub>6</sub> to C<sub>10</sub> as gasoline range organics (GRO) in samples of various matrices (i.e. soils, water, sludge). Other range of alkanes may be applied (e.g., C<sub>5</sub> to C<sub>10</sub>, C<sub>6</sub> to C<sub>12</sub>, etc.) or other purgeable fuel patterns such as JP4 and Stoddard may be analyzed provided that qualitative identification and quantitative determination is properly established.
- 1.2. This SOP is an adaptation of SW846 Method 8015C. This SOP is also applicable to SW846 Method 8015B and Method 8015D.

**2.0 SUMMARY OF METHOD**

- 2.1. A known amount of sample is purged by inert gas into a trap and retains the purgeable organic compounds. The trap is back flushed into the GC system equipped with flame ionization detector (FID). The instrument is calibrated with a gasoline standard. Hydrocarbon markers (C<sub>5</sub> to C<sub>12</sub>) are analyzed to determine elution time. Quantitation of typical GRO is based on C<sub>6</sub> to C<sub>10</sub> alkane range.
- 2.2. **Interferences**
- 2.2.1. Glassware can be a potential source of contamination. They must be scrupulously cleaned prior to use.
- 2.2.2. Carry-over from a highly concentrated sample can be a potential source of contamination. Instrument performance must be observed keenly for possible carry-over. If this is apparent, inject solvent blank until no trace of carry-over is observed.

**3.0 DETECTION LIMITS****3.1. Detection Limit (DL), Limit of Detection (LOD) & Limit of Quantitation (LOQ)**

- 3.1.1. Refer to EMAX-QA04 for generation, validation and verification for DL, LOD and LOQ.
- 3.1.2. Established DL, LOD and LOQ are as follows:

| Analyte  | Water<br>(µg/L) |     |     | Soil 1 gm to 5 mL<br>(µg/Kg) |     |     | Soil 5 gm to 5<br>mLMeOH (µg/Kg) |     |      |
|----------|-----------------|-----|-----|------------------------------|-----|-----|----------------------------------|-----|------|
|          | DL              | LOD | LOQ | DL                           | LOD | LOQ | DL                               | LOD | LOQ  |
| Gasoline | 5               | 10  | 20  | 20                           | 40  | 100 | 350                              | 500 | 1000 |
| JP4      | 8.4             | 10  | 20  | -                            | -   | -   | 250                              | 500 | 1000 |

## STANDARD OPERATING PROCEDURES

**GASOLINE RANGE ORGANICS**SOP No.: EMAX-8015G Revision No. 5 Effective Date: 24-Jan-14

| Analyte                | Water (µg/L) |     |     | Soil 1 gm to 5 mL (µg/Kg) |     |     | Soil 5 gm to 5 mL MeOH (µg/Kg) |     |      |
|------------------------|--------------|-----|-----|---------------------------|-----|-----|--------------------------------|-----|------|
|                        | DL           | LOD | LOQ | DL                        | LOD | LOQ | DL                             | LOD | LOQ  |
| Stoddard               | 10           | 20  | 50  | -                         | -   | -   | 250                            | 500 | 1000 |
| Bromofluorobenzene     | 2.5          | 5   | 20  | 10                        | 20  | 100 | 50                             | 100 | 1000 |
| 1,1,1-Trifluorotoluene | 2.5          | 5   | 20  | 10                        | 20  | 100 | 50                             | 100 | 1000 |

**4.0 DYNAMIC RANGE**

- 4.1. The highest quantifiable range requiring no dilution is equal to the concentration of the highest calibration point (See Section 9.3.1). Dilute and re-analyze all samples having results above this range for proper quantitation.
- 4.2. The lowest quantifiable range of diluted samples is equal to the lowest calibration point (See Section 9.3.1). Lower the dilution factor and re-analyze all diluted samples analyzed below this range for proper quantitation.

**5.0 SAMPLE HOLDING TIME & PRESERVATION****5.1. Holding Time****5.1.1. Aqueous Samples**

- 5.1.1.1. Analyze preserved samples within 14 days from sampling date.
- 5.1.1.2. If pH > 2, analyze samples within 7 days from sampling date.

**5.1.2. Soil Samples**

- 5.1.2.1. Samples received in encores are extracted with methanol within 48 hours from sampling time and analyzed within 14 days from sampling date unless otherwise specified by the project.
- 5.1.2.2. Sample received in jars are extracted with methanol and analyzed within 14 days from sampling date.
- 5.1.2.3. Analyze soil samples (1gram direct purge) within 14 days from sampling date.

**5.2. Preservation**

- 5.2.1. Water samples received are expected to be contained in 40 ml vial with teflon-lined septa preserved at pH < 2 with HCl with zero head space.
- Note: The size of any bubble caused by degassing upon cooling the sample should not exceed 6 mm.<sup>1</sup>
- 5.2.2. Store samples and extracts at ≤ 6°C.

<sup>1</sup> Referenced from SW846 Method 5030C, Section 8.1.

## STANDARD OPERATING PROCEDURES

**GASOLINE RANGE ORGANICS**SOP No.: EMAX-8015G Revision No. 5 Effective Date: 24-Jan-14**6.0 ASSOCIATED SOPs**

- 6.1. EMAX-5030 Purge and Trap
- 6.2. EMAX-5035 Purge and Trap, Closed System
- 6.3. EMAX-DM01 Data Flow and Review
- 6.4. EMAX-QA04 Detection Limit
- 6.5. EMAX-QA05 Training
- 6.6. EMAX-QA08 Corrective Action
- 6.7. EMAX-QC01 Quality Control of Chemicals
- 6.8. EMAX-QC02 Analytical Standard Preparation
- 6.9. EMAX-QC07 Glassware Cleaning
- 6.10. EMAX-SM03 Waste Disposal
- 6.11. EMAX-SM04 Analytical and QC Sample Labeling

**7.0 SAFETY**

- 7.1. Read all SDS of chemicals listed in this SOP.
- 7.2. Treat all reagents, standards, and samples as potential hazards. Observe the standard laboratory safety procedures. Wear protective gear, i.e., lab coat, safety glasses, gloves, at all times when performing this procedure. Perform all sample and standard handling in the fume hood.
- 7.3. If for any reason, solvent and/or other reagents get in contact with your skin or any other part of your body, rinse the affected body part thoroughly with copious amounts of water. If irritations persist, inform your supervisor immediately so that proper action can be taken.

**8.0 INSTRUMENTS, CHEMICALS & REAGENTS****8.1. Instruments and Supplies**

|                                      |   |
|--------------------------------------|---|
| Purge and Trap System (Concentrator) | LSC 2000 Tekmar (GC39)/OI4560 or equivalent (GC55)  |
| Autosampler                          | Archon or equivalent  |
| Gas Chromatography                   | HP 5890 Series II, GC with FID  |
| Column                               | DB5 – 30m x .53 mm, 1.5 µm thickness, or equivalent   |
| Gas                                  | ultra-high purity helium, ultra-high purity hydrogen, hydrogen generator unit, compressed air |
| Syringes                             | 5 ml Luerlok hypodermic gas-tight   |
| Microsyringes                        | Hamilton or equivalent  |
| Data System                          | EZ-Chrom  |

## STANDARD OPERATING PROCEDURES

**GASOLINE RANGE ORGANICS**SOP No.: EMAX-8015G Revision No. 5 Effective Date: 24-Jan-14

|            |                                 |
|------------|---------------------------------|
| Purge Trap | Supelco, Trap "G" or equivalent |
|------------|---------------------------------|

**8.2. Chemicals and Reagents**

- 8.2.1. Methanol, purge and trap
- 8.2.2. Organic-free Reagent Water
- 8.2.3. Organic-free Ottawa Sand

**9.0 STANDARDS****9.1. Stock Standard**

9.1.1. Purchase stock standards or equivalent as certified solutions traceable to NIST standards.

| Name                        | Source       | Solvent  | Conc. (µg/mL) | Intended Use |
|-----------------------------|--------------|----------|---------------|--------------|
| Unleaded Gas Comp. Standard | Restek       | Methanol | 2,500         | Calibration  |
| Stoddard Solvent Standard   | Restek       | Methanol | 10,000        | Calibration  |
| JP4 Standard                | Restek       | Methanol | 50,000        | Calibration  |
| Cert. BTEX Unleaded Gas     | AccuStandard | Methanol | 5,000         | ICV/LCS/MS   |
| Stoddard Solvent            | AccuStandard | Methanol | 20,000        | ICV/LCS/MS   |
| JP4 Jet Fuel                | AccuStandard | Methanol | 20,000        | ICV/LCS/MS   |

**9.2. Intermediate Standards**

- 9.2.1. Intermediate and working standards are prepared according to EMAX-QC02.
- 9.2.2. All standards should be transferred in inert vials labeled with ID from standard preparation logbook, date of expiration, concentration, and stored with minimal headspace at -10°C to -20°C.
- 9.2.3. Intermediate standards are prepared only for Stoddard and JP4 as follows:

| Stock Standard                            |               |              | Solvent  | Intermediate Standard |                    |
|---|---------------|--------------|----------|-----------------------|--------------------|
| Standard Name                             | Conc. (µg/ml) | Aliquot (µl) |          | Final Vol. (ml)       | Final Conc. (mg/L) |
| Stoddard Solvent (1 <sup>st</sup> source) | 10,000        | 500          | Methanol | 2                     | 2,500              |
| Stoddard Solvent (2 <sup>nd</sup> source) | 20,000        | 250          | Methanol | 2                     | 2,500              |
| JP4 Standard (1 <sup>st</sup> source)     | 50,000        | 100          | Methanol | 2                     | 2,500              |
| JP4 Standard (2 <sup>nd</sup> source)     | 20,000        | 250          | Methanol | 2                     | 2,500              |

**9.3. Calibration Standards**

- 9.3.1. Initial Calibration Standards
  - 9.3.1.1. Gasoline

## STANDARD OPERATING PROCEDURES

**GASOLINE RANGE ORGANICS**SOP No.: EMAX-8015G Revision No. 5 Effective Date: 24-Jan-14

Prepare initial calibration standards in 5 ml organic- free water with concentrations as suggested below:

| ICAL Standard | Aliquot ( $\mu$ l)            |                                 | Final Conc. ( $\mu$ g/L)<br>Gasoline /Surrogate |
|---------------|-------------------------------|---------------------------------|---|
|               | Gasoline Std.<br>(2,500 mg/L) | Surrogate BFB/TFT<br>(100 mg/L) |   |
| 1             | 0.04                          | 0.5                             | 20/10   |
| 2             | 0.1                           | 1                               | 50/20   |
| 3             | 0.2                           | 1.5                             | 100/30  |
| 4             | 1                             | 2                               | 500/40  |
| 5             | 2                             | 2.5                             | 1000/50   |
| 6             | 4                             | 3.75                            | 2000/75   |
| 7             | 5 $\mu$ l                     | 5                               | 2500/100  |

9.3.1.2. Stoddard

Prepare initial calibration standards in 5 ml organic- free water with concentrations as suggested below:

| ICAL Standard | Aliquot ( $\mu$ L)            |                                 | Final Conc. ( $\mu$ g/L)<br>Stoddard / Surrogate |
|---------------|-------------------------------|---------------------------------|--|
|               | Stoddard Std.<br>(2,500 mg/L) | Surrogate BFB/TFT<br>(100 mg/L) |  |
| 1             | 0.04                          | 0.5                             | 20/10  |
| 2             | 0.1                           | 1                               | 50/20  |
| 3             | 0.2                           | 1.5                             | 100/30   |
| 4             | 1                             | 2                               | 500/40   |
| 5             | 2                             | 2.5                             | 1000/50  |
| 6             | 3                             | 3                               | 1500/60  |

9.3.1.3. JP4

Prepare initial calibration standards in 5 ml organic- free water with concentrations as suggested below:

| ICAL Standard | Aliquot ( $\mu$ L)       |                                 | Final Conc. ( $\mu$ g/L)<br>JP4/ Surrogate |
|---------------|--------------------------|---------------------------------|--|
|               | JP4 Std.<br>(2,500 mg/L) | Surrogate BFB/TFT<br>(100 mg/L) |  |
| 1             | 0.04                     | 0.5                             | 20/10                                      |
| 2             | 0.1                      | 1                               | 50/20                                      |
| 3             | 0.2                      | 1.5                             | 100/30                                     |

## STANDARD OPERATING PROCEDURES

**GASOLINE RANGE ORGANICS**SOP No.: EMAX-8015G Revision No. 5 Effective Date: 24-Jan-14

| ICAL Standard | Aliquot (µL)             |                                 | Final Conc. (µg/L)<br>JP4/ Surrogate |
|---------------|--------------------------|---------------------------------|--------------------------------------|
|               | JP4 Std.<br>(2,500 mg/L) | Surrogate BFB/TFT<br>(100 mg/L) |                                      |
| 4             | 1                        | 2                               | 500/40                               |
| 5             | 2                        | 2.5                             | 1000/50                              |
| 6             | 4                        | 3.75                            | 2000/75                              |
| 7             | 5                        | 5                               | 2500/100                             |

9.3.2. Initial Calibration Verification Standards

Prepare initial calibration verifications standards (using second-source standards) in 5 ml organic-free water with concentrations as suggested below:

| ICV Standard | Intermediate Std. (2 <sup>nd</sup> source) |                 | Surrogate BFB/TFT<br>(100 mg/L)<br>Aliquot in µL | Final Conc. (µg/L)<br>Analyte /<br>Surrogate |
|--------------|--|-----------------|--|--|
|              | Concentration<br>(mg/L)                    | Aliquot<br>(µL) |  |  |
| Gasoline     | 5000                                       | 1               | 2.5  | 1000/50                                      |
| Stoddard     | 2500                                       | 2               | 2.5  | 1000/50                                      |
| JP4          | 2500                                       | 2               | 2.5  | 1000/50                                      |

9.3.3. Continuing Calibration Standard

Using intermediate standards, prepare daily calibration standards in a syringe with 5 ml of organic-free water as suggested below:

| DCC Standard | Intermediate Std. (1 <sup>st</sup> source) |                 | Surrogate BFB/TFT<br>(100 mg/L)<br>Aliquot in µL | Final Conc. (µg/L)<br>Analyte /<br>Surrogate |
|--------------|--|-----------------|--|--|
|              | Concentration<br>(mg/L)                    | Aliquot<br>(µL) |  |  |
| Gasoline     | 2500                                       | 2               | 2.5  | 1000/50                                      |
| Stoddard     | 2500                                       | 2               | 2.5  | 1000/50                                      |
| JP4          | 2500                                       | 2               | 2.5  | 1000/50                                      |

9.4. **LCS/Matrix Spike Standard**

9.4.1. Use second-source intermediate standards for laboratory control standard (LCS) and matrix spike (MS) standards. Refer to Section 9.2.3 for Stoddard and JP4. Use Gasoline standard from AccuStandard (5,000 mg/L) for gasoline spike.

9.5. **Surrogate Standards**

9.5.1. Purchase stock standards or equivalent as certified solutions traceable to NIST standards.

## STANDARD OPERATING PROCEDURES

**GASOLINE RANGE ORGANICS**SOP No.: EMAX-8015G Revision No. 5 Effective Date: 24-Jan-14

| Name                     | Source           | Solvent  | Conc. ( $\mu\text{g}/\text{mL}$ ) |
|--------------------------|------------------|----------|-----------------------------------|
| Bromofluorobenzene / TFT | Ultra Scientific | Methanol | 2000                              |

9.5.2. Prepare intermediate surrogate standard as follows:

| Stock Standard           |                                   |                           | Solvent  | Intermediate Standard |                    |
|--------------------------|-----------------------------------|---------------------------|----------|-----------------------|--------------------|
| Standard Name            | Conc. ( $\mu\text{g}/\text{mL}$ ) | Aliquot ( $\mu\text{L}$ ) |          | Final Vol. (ml)       | Final Conc. (mg/L) |
| Bromofluorobenzene / TFT | 2000                              | 100                       | Methanol | 2                     | 100                |

9.6. **Retention Time Window Standard**

9.6.1. Purchase the following standards or equivalent.

| Name                   | Source           | Conc. (mg/L) |
|------------------------|------------------|--------------|
| GRO                    | AccuStandard     | 2000         |
| 2-Methylpentane        | Supelco          | 2000         |
| 1,2,4-Trimethylbenzene | Ultra Scientific | 5000 *       |
| DRO                    | AccuStandard     | 2000         |

\* Dilute to 2000 mg/L before use for retention time analysis.

9.7. Other concentration levels may be used as appropriate.

**10.0 PROCEDURES****10.1. Sample Preparation**

- 10.1.1. Prepare aqueous samples in accordance with EMAX-5030. Add surrogates to all samples to yield 40 $\mu\text{g}/\text{L}$  prior to purging unless otherwise specified by the project.
- 10.1.2. Prepare soil samples in accordance with EMAX-5035. Add surrogates to all samples to yield 40 $\mu\text{g}/\text{Kg}$  prior to purging unless otherwise specified by the project.
- 10.1.3. Prepare LCS/LCD by spiking a reagent blank to yield 500  $\mu\text{g}/\text{L}$  spike standard unless otherwise specified by the project. Add surrogate at the same level as the samples.
- 10.1.4. Prepare MS/MSD sample using the assigned matrix QC sample similarly as the LCS sample.

**10.2. Instrument Parameters**

10.2.1. Initially, set the instrument parameters as suggested in the table below.

10.2.2. Gas Chromatographic Condition

|                                     |              |
|-------------------------------------|--------------|
| Carrier gas flow (column)<br>helium | 9-10 ml/min  |
| Make up gas (He)                    | 20-21 ml/min |

## STANDARD OPERATING PROCEDURES

**GASOLINE RANGE ORGANICS**SOP No.: EMAX-8015G Revision No. 5 Effective Date: 24-Jan-14

|          |        |
|----------|--------|
| Air      | 60 psi |
| Helium   | 80 psi |
| Hydrogen | 50 psi |

| <b>Temperature Settings:</b> |               |              |                              |               |              |
|------------------------------|---------------|--------------|------------------------------|---------------|--------------|
| <b>Inst. GC 39</b>           |               |              | <b>Inst. GC 55</b>           |               |              |
| Injector Temperature: OFF    |               |              | Injector Temperature: 150 °C |               |              |
| Detector Temperature: 235 °C |               |              | Detector Temperature: 235 °C |               |              |
| Temp °C                      | Hold Time,min | Rate, °C/min | Temp °C                      | Hold Time,min | Rate, °C/min |
| 35                           | 6             | 0            | 35                           | 6             | 0            |
| 70                           | 0             | 8            | 70                           | 0             | 8            |
| 120                          | 3             | 5            | 120                          | 3             | 5            |
| 245                          | 4             | 30           | 245                          | 3             | 30           |

10.2.3. Purge and Trap Condition

|                            | <b>Inst. GC 39</b> | <b>Inst. GC 55</b> |
|----------------------------|--------------------|--------------------|
| Purge                      | 10 mins at 40 °C   | 15 mins at 30 °C   |
| Dry Purge / Desorb Preheat | 3 mins at 170 °C   | 1 min at 180 °C    |
| Desorb                     | 2 mins at 180 °C   | 2 mins at 180 °C   |
| Bake                       | 14 mins at 185 °C  | 10 mins at 220 °C  |

10.2.4. Optimize the instrument for its intended use.

10.2.5. Record the instrument operating condition on the instrument maintenance log and post the latest instrument parameter setup in front of the instrument for ease when performing the instrument routine check.

10.2.6. When instrument parameter setup requires change due to instrument optimization document the change as described in Section 10.2.5.

10.3. **Calibration**10.3.1. Initial Calibration (ICAL)

10.3.1.1. Analyze initial calibration standards (Refer to Section 9.3.1 for standard preparation) as described in Section 10.4.

10.3.1.2. Refer to Section 10.5 for calculation.

10.3.1.3. Acceptance criteria are specified in Appendix 1.

10.3.2. Initial Calibration Verification (ICV)



## STANDARD OPERATING PROCEDURES

**GASOLINE RANGE ORGANICS**

SOP No.: EMAX-8015G Revision No. 5 Effective Date: 24-Jan-14

---

10.3.2.1. After establishing ICAL, analyze the ICV standard (Refer to Section 9.3.2 for standard preparation) to verify the validity of the ICAL. Refer Appendix 1 for acceptance criteria. If non-compliant refer to Section 12 for corrective action.

10.3.3. Retention Time Window Check (RTW)

10.3.3.1. Spike 5 ml water reagent with 0.5 µL of 2000 mg/L RTW standard.

10.3.3.2. Analyze the RTW standard after every ICAL to set carbon cut-off ranges (e.g, C<sub>6</sub> - C<sub>10</sub>, C<sub>5</sub> - C<sub>12</sub>). Refer to Section 10.4.3.

10.3.4. Continuing Calibration (DCC)

10.3.4.1. Analyze the DCC standard (Refer to Section 9.3.3 for standard preparation) to verify the validity of the ICAL. Refer to Appendix 1 for acceptance criteria. If non-compliant refer to Section 12 for corrective action.

**10.4. Analysis**

10.4.1. Analytical Sequence

10.4.1.1. Analyze instrument blank to ensure that the instrument is free from contamination.

10.4.1.2. Analyze DCC to check ICAL validity.

10.4.1.3. Analyze Method Blank to check for preparation batch contamination.

10.4.1.4. Analyze Lab Control Sample to check accuracy.

10.4.1.5. Analyze Lab Control Sample Duplicate (if required by the project).

10.4.1.6. Analyze samples to a maximum number of 12-hour runs or as specified by the project.

10.4.1.7. Analyze matrix spikes (MS/MSD) per project requirement.

10.4.1.8. Record the analytical sequence in the Analytical Run Log.

10.4.1.9. Print instrument sequence before and after the analysis run and attach to the analytical run. Document any changes that occurred during the process.

10.4.2. Identification and Quantitation

10.4.2.1. Identification is based on pattern recognition. Hence, compare sample chromatograms to reference hydrocarbons standard chromatograms for their response hydrocarbon range and peak distribution to determine the most probable petroleum product.

10.4.2.2. All peaks eluting within the established RT window identifies the GRO, JP4 and Stoddard.

10.4.2.3. When the elution profile of a sample does not match that of gasoline standard, JP4 or Stoddard, but falls within the retention time window, quantitate results as gasoline range organics (GRO) and denote the observed deviation in case narrative.

10.4.2.4. Quantitation is achieved by the summation of all peaks in the chromatogram minus the solvent peak, and the sample result is calculated using Equation 10.5.3.

10.4.2.5. Integrate the total peak area response and quantitate the total area by using the ACF of Gasoline, JP4 or Stoddard (see section 10.5.1).

## STANDARD OPERATING PROCEDURES

**GASOLINE RANGE ORGANICS**SOP No.: EMAX-8015G Revision No. 5 Effective Date: 24-Jan-14

---

10.4.2.6. When manual integration is necessary follow the procedures described in EMAX-DM01 Section 4.4.3.

10.4.3 Retention Time Windows (RTW)

10.4.3.1 Establishing RTW

10.4.3.1.1 Run RTW standard over a period of 72 hours.

10.4.3.1.2 Calculate the Standard Deviation (SD) of absolute retention time obtained for each analyte (Use Equation 10.5.1.2).

10.4.3.1.3 The width of RTW is defined by  $\pm 3XSD$  obtained from Section 10.4.3.1.2.

10.4.3.2 Evaluating RTW

10.4.3.2.1 If the SD is equal to 0.00, default to the previous study until historical data is obtained to define the RTW for the current instrument.

10.4.3.2.2 For new instruments, use the established retention time from another instrument having the same instrument parameters (e.g. detector, temperature program and column.) If there are no instruments with the same instrument parameter, use 0.03 minutes as the default RTW until historical data is obtained to define the RTW for the current instrument parameters condition.

10.4.3.3 Application of RTW

10.4.3.3.1 Establish the center of absolute retention time for each analyte to include the surrogate(s) from the daily calibration check at the beginning of the analytical shift then apply the established RTW.

10.4.3.3.2 Whenever the observed retention time is outside the established RTW, the analyst is advised to determine the cause and perform necessary corrective action before continuing analyses.

10.4.3.4 Updating RTW

10.4.3.4.1 Re-establish the RTW as described in Section 10.4.3.1 when any of the following conditions occur.

- Yearly RTW update
- Significant shifting is observed (e.g. succeeding calibration checks or LCS are out of the RTW)
- Major instrument maintenance (e.g. replacements of detector or column, temperature program change, etc.)

10.4.3.4.2 If the calculated new RTW is significantly narrower than the previously established RTW, default to the previously established RTW.

10.4.4 Sample Result Evaluation

10.4.4.1 Check surrogate recoveries against project specific requirement (PSR). In the absence of PSR, default to in-house QC procedures described in Appendix 1.

## STANDARD OPERATING PROCEDURES

**GASOLINE RANGE ORGANICS**SOP No.: EMAX-8015G Revision No. 5 Effective Date: 24-Jan-14

- 10.4.4.2 Dilute and re-analyze samples having concentrations greater than the highest calibration range.
- 10.4.4.3 Dilute and re-analyze samples having saturated peak(s) within C<sub>6</sub> – C<sub>10</sub>. See Figure 1 for typical saturated peak.
- 10.4.4.4 Re-analyze samples suspected of carry-over from a proceeding sample that has high concentration.
- 10.4.4.5 Report discrete peak(s) observed as required by the project. Column bleed subtraction is not generally required in GRO analysis.

**10.5 Calculations****10.5.1 Initial Calibration****10.5.1.1 Calculate the Calibration Factor (CF)**

$$CF = \frac{R_a}{C_k} \quad \text{Eq.-10.5.1.1}$$

*where:**CF* - is the calibration factor*R<sub>a</sub>* - is the analyte response measured in peak area*C<sub>k</sub>* - is the known concentration of the analyte in µg/L (water); µg/Kg (soil)**10.5.1.1 Calculate the Standard Deviation**

$$SD = \sqrt{\frac{\sum_{i=1}^N (x_i - \bar{x})^2}{N - 1}} \quad \text{Eq.-10.5.1.2}$$

*where:**SD* - is the standard deviation*x<sub>i</sub>* - is the result at the *i*<sup>th</sup> measurement *$\bar{x}$*  - is the mean*N* - is the number of measurements**10.5.1.1 Calculate the Percent Relative Standard Deviation (%RSD)**

$$\%RSD = \left[ \frac{SD}{ACF} \right] 100 \quad \text{Eq.-10.5.1.3}$$

*where:**%RSD* - is the percent relative standard deviation*SD* - is the standard deviation*ACF* - is the average calibration factor

## STANDARD OPERATING PROCEDURES

**GASOLINE RANGE ORGANICS**SOP No.: EMAX-8015G Revision No. 5 Effective Date: 24-Jan-14**10.5.1.1 Calculate the Average Calibration Factor (ACF)**

$$ACF = \frac{\sum CF}{N} \quad \text{Eq.-10.5.1.4}$$

*where:**ACF - is the average calibration factor* *$\sum CF$  - is the summation of the calibration factors**N - is the number of calibration points***10.5.2 Calculate the Percent Difference for DCC from ACF**

$$\%D = \frac{|C_k - C_f|}{C_k} * 100 \quad \text{Eq.-10.5.2}$$

*where:**%D - is the percent difference DCC from the ACF**C<sub>k</sub> - is the known concentration of analyte, in µg/L**C<sub>f</sub> - is the concentration found, in µg/L***10.5.3 Calculate Sample Results****10.5.3.1 Water Samples**

$$C = \left[ \frac{R_a}{ACF} \right] \left[ \frac{V_e}{S_a} \right] DF \quad \text{Eq.-10.5.3.1}$$

**10.5.3.1 Soil Samples**

$$C = \left[ \frac{R_a}{ACF} \right] \left[ \frac{V_e}{(S_a)(\%S)} \right] DF \quad \text{Eq.-10.5.3.2}$$

*where:**C - is the concentration of analyte in µg/L (water), µg/Kg (soil)**R<sub>a</sub> - is the analyte response measured in peak area**ACF - is the average calibration factor from initial standard calibration**V<sub>e</sub> - is the purgeable volume in ml**S<sub>a</sub> - is the sample amount in ml (water); g (soil)**DF - is the dilution factor**%S - is the percent solid of the sample***10.5.4 Accuracy and Precision****10.5.4.1 Percent Recovery**

## STANDARD OPERATING PROCEDURES

**GASOLINE RANGE ORGANICS**SOP No.: EMAX-8015G Revision No. 5 Effective Date: 24-Jan-14

$$\% R = \left[ \frac{(C_f - C_s)}{C_o} \right] 100 \quad \text{Eq.-10.5.4.1}$$

where:

% - is the percent recovery

$C_f$  - is the concentration found, in  $\mu\text{g/L}$

$C_s$  - is the concentration of the sample in  $\mu\text{g/L}$  (water); in  $\mu\text{g/Kg}$  (soil). For LCS,  $C_s=0$

$C_o$  - is the known concentration of spiked solution

#### 10.5.4.1 Relative Percent Difference

$$\% RPD = \frac{|C_1 - C_2|}{\left( \frac{C_1 + C_2}{2} \right)} \times 100 \quad \text{Eq.-10.5.4.2}$$

where:

RPD - is the relative percent difference

$C_1$  - is the measured concentration of the first sample aliquot

$C_2$  - is the measured concentration of the second sample aliquot

### 10.6 Data Reduction

- 10.6.1 Make a copy of the analytical run log and sample preparation log.
- 10.6.2 Print a copy of the raw data and the QC report.
- 10.6.3 Highlight the data to be reported.
- 10.6.4 Collate the reportable raw data separating the QC results from the sample results.
- 10.6.5 Keep all other data generated with the analytical folder marked with "For record only".

### 10.7 Report Generation

- 10.7.1 Generate the method.txt file using WDBX<sup>2</sup>.exe.
- 10.7.2 Generate the sample results using F1NVX<sup>2</sup>.exe
- 10.7.3 Generate the QC summary using QCVX<sup>2</sup>.exe
- 10.7.4 Generate Lab Chronicle using LABCHRNX<sup>2</sup>.exe
- 10.7.5 Generate the Case Narrative using CN1.exe

### 10.8 Data Review

<sup>2</sup> X – version number of the program.

## STANDARD OPERATING PROCEDURES

**GASOLINE RANGE ORGANICS**

SOP No.: EMAX-8015G Revision No. 5 Effective Date: 24-Jan-14

---

- 10.8.1 Arrange the analysis package in sequence as detailed below using section separators. Attach all raw data to every form generated, to include manual integration(s) and re-analyses.
- Case Narrative
  - Lab Chronicle
  - Sample Results
  - LCS/LCSD Summary
  - MS/MSD Summary
  - ICAL Summary
  - ICV Summary
  - DCC Summary
  - Analytical Log
  - Sample Preparation Log
  - Non-Conformance Report (if any)
- 10.8.2 Perform a 100% data review in accordance to EMAX-DM01 and the PSR.
- ✓ Check that qualitative identification is done properly.
  - ✓ Check that surrogate recoveries against Project Specific Requirement (PSR). In the absence of PSR, default to in-house QC limits.
  - ✓ Check that sample results are integrated properly and results over calibration range are diluted and re-analyzed within the calibration range.
  - ✓ Where manual integration was performed, check that it was done properly and documentation was retained in accordance to EMAX-DM01 Section 4.4.3.
  - ✓ Check that presence of saturated peak(s) are diluted, and quantitated properly.
  - ✓ Check that suspected carry-overs are re-analyzed and results are reported accordingly.
  - ✓ Check that discrete peaks [other than column bleeds] are reported according to project requirement.
  - ✓ If any of the above checkpoints indicate a problem, re-analysis is required.
- 10.8.3 Review the attached logs that they are properly filled.
- 10.8.4 Check the generated reports against the raw data. Check that the analytical data generated indicating positive results are qualitatively and quantitatively correct.
- 10.8.5 Review the case narrative and check that it accurately describes what transpired in the analytical process. Edit as necessary to reflect essential issues not captured by the case narrative generator program.
- 10.8.6 Submit the analytical folder for secondary review.

**10.9 Preventive Maintenance**

## STANDARD OPERATING PROCEDURES

**GASOLINE RANGE ORGANICS**SOP No.: EMAX-8015G Revision No. 5 Effective Date: 24-Jan-14

- 10.9.1 On a daily basis, perform the checks listed in the instrument maintenance log prior to sample analysis. Refer to Form 8015GFM – Instrument Maintenance Log.
- 10.9.2 Conduct routine preventive instrument maintenance and document the activity in the instrument-specific maintenance log. Routine maintenance ensures that all equipment are operating under optimum conditions, thus reducing the possibility of instrument malfunction, and consequently affecting sample results. Routine maintenance activities are suggested below:

| Maintenance Activity       | Description  | Frequency                      |
|----------------------------|--|--------------------------------|
| Autosampler                | Inspect autosampler needle and check response.   | Daily prior to analysis.       |
| Verification               | Check gas pressure<br>Check instrument parameters to ensure normal operating conditions.<br>Check instrument performance (e.g., Daily calibration check, instrument blank) | Daily prior to analysis.       |
| Documentation              | Record all instrument maintenance performed in the instrument maintenance log.   | Daily prior to analysis        |
| System Cleaning            | Remove dust from fans and vent covers.<br>Lubricate mechanical parts.  | Every 6 months or as necessary |
| Check Flow Path Components | Change the carrier gas trap(s) and purifier  | Once a year or as necessary    |
| Complete Inspection        | Perform general inspection of the complete system. Inspect autosampler cabling and configuration setting.<br>Replace column if necessary.<br>Replace worn out parts.       | Once a year                    |

- 10.9.3 Maintain an inventory of instrument parts and supplies for routine maintenance.

**11.0 QUALITY CONTROL****11.1. Sample Preparation**

- 11.1.1. A preparation batch shall consist of a MB, LCS, MS/MSD and  $\leq 20$  field samples.
- 11.1.2. Decontaminate volumetric flasks used for standard preparation with methanol.
- 11.1.3. All solvents and reagents shall undergo quality control check in the stationary laboratory prior to its use in accordance to EMAX-QC01.

**11.2. Analytical Batch**

## STANDARD OPERATING PROCEDURES

**GASOLINE RANGE ORGANICS**SOP No.: EMAX-8015G Revision No. 5 Effective Date: 24-Jan-14

- 
- 11.2.1. Initial Calibration must be established and verified by daily continuing calibration as described in Appendix 1.
  - 11.2.2. Analytical batch shall consist of a valid ICAL, QC samples and field samples bracketed with DCC every 12-hour analytical sequence, unless other frequency is prescribed by the project.
  - 11.2.3. A record must be established that the analytical instrument is free from contamination prior to any analysis. This can be achieved by analyzing a solvent blank and identifying its result as instrument blank.
  - 11.2.4. Organic-free water shall be used for method blank and LCS for water matrix.
  - 11.2.5. Organic-free sand shall be used for method blank and LCS for soil matrix.

**11.3. Method QC**

- 11.3.1. LOD and LOQ must be established before the analytical procedure can be used and verified according to EMAX-QA04.
- 11.3.2. Retention Time Window must be established and updated as prescribed.
- 11.3.3. Demonstration of capability must be established before the analytical procedure can be used.
- 11.3.4. All analysts conducting this analysis must have established demonstration of capability.

**12.0 CORRECTIVE ACTION**

12.1. Corrective actions associated with this analytical procedure are described in the Summary of Quality Control Procedures (Refer to Appendix 1).

**12.2. Calibration**

- 12.2.1. If initial calibration is non-compliant, consider the following suggestions to correct the problem:
  - 12.2.1.1. If RSD > 20%, check each calibration point. If an outlier exists, re-analyze that calibration point.
  - 12.2.1.2. If ICV not within the expected recovery range, review the chromatogram.
    - Bias low results are indicative of poor purging or standard degradation.
    - Bias high is indicative of inaccurate standard injection of instrument or contamination.
    - Consider preparing a fresh ICV standard and re-analyze the ICV.
  - 12.2.1.3. If problem persists, inform the Supervisor prior to re-calibration
- 12.2.2. If the continuing calibration is non-compliant, consider the suggestions described in correcting ICV.
- 12.2.3. If instrument blank/reagent blank is non-compliant, consider the following suggestions to correct the problem:
  - 12.2.3.1. Check the reagent water source, e.g. check if same source was used by a similar analysis on a different instrument to rule out reagent contamination.
  - 12.2.3.2. Bake the sample concentrator and/or GC column for at least 15 min.



## STANDARD OPERATING PROCEDURES

**GASOLINE RANGE ORGANICS**

SOP No.: EMAX-8015G Revision No. 5 Effective Date: 24-Jan-14

---

12.2.3.3. Re-calculate the data and/or re-analyze the extract, if any of the above checks reveal a problem.

12.2.3.4. If problem persists, inform the Supervisor prior to re-analysis.

**12.3. Surrogates**

12.3.1. If surrogates are non-compliant, but is not due to matrix effects, consider the following suggestions to correct the problem:

12.3.1.1. Check that the surrogate peak is properly integrated.

12.3.1.2. Check for calculation errors and that the concentrations of the surrogate solutions are correct.

- High recoveries may be due to co-eluting matrix interference, examine the sample chromatogram.
- Low recoveries may be due to a poor purge, check the purge tube with a blank before re-analyzing the sample.

12.3.1.3. Check instrument performance to determine if it is within acceptable guidelines.

**12.4. Sample Preparation QCs**

12.4.1. If method blank is non-compliant, consider the following suggestions to correct the problem:

- Check the sample results. If sample results are non-detect, you may report the result upon concurring with the PM.
- If sample results are not reportable, determine the source of contamination and correct the problem. Reanalyze method blank and all samples processed with the contaminated blank.

12.4.2. If LCS is non-compliant, consider the following suggestions to correct the problem:

- Check for standard degradation. Prepare a new LCS standard.
- Check instrument performance to determine if it is within acceptable guidelines.
- Reanalyze the extract if any of the above checks reveal a problem.
- Otherwise, re-extract all samples associated with the non-compliant LCS with a new set of QC samples.

12.5. A Non-Conformance Report (NCR) is required when any of the following circumstances occur:

- Anomalies, other than specified in Appendix 1, are observed.
- Sample is out of technical holding time.

12.5.1. Refer to EMAX-QA08 for NCR details.

**13.0 POLLUTION PREVENTION**

13.1. Observe all necessary precautions to avoid spillage of solvent that may go to wastewater drains.

13.2. Prepare all standards in fume hoods.

## STANDARD OPERATING PROCEDURES

**GASOLINE RANGE ORGANICS**

SOP No.: EMAX-8015G Revision No. 5 Effective Date: 24-Jan-14

---

**14.0 WASTE MANAGEMENT**

- 14.1. No samples may be dumped on the laboratory sink.
- 14.2. Separate and properly identify all unused expired analytical standards for proper disposal.
- 14.3. Place all wastes generated during analytical process in properly labeled satellite waste containers for proper collection.
- 14.4. Dispose all unused samples, expired analytical standards and other waste generated during the analytical process in accordance to EMAX-SM03.

**15.0 SUPPLEMENTARY NOTES****15.1. Definition of Terms**

- 15.1.1. Batch – is a group of samples that are prepared and/or analyzed at the same time using the same lot of reagents. Preparation batch is composed of one to 20 samples of the same matrix, a method blank, a lab control sample and matrix spike/matrix spike duplicate. Analytical batch is composed of prepared samples (extracts, digestates, or concentrates), which are analyzed together as a group using an instrument in conformance to the analytical requirement. An analytical batch can include samples originating from various matrices, preparation batches, and can exceed 20 samples.
- 15.1.2. Calibration – is a determinant measured from a standard to obtain the correct value of an instrument output.
- 15.1.3. Duplicate Sample – is a replicate of a sub-sample taken from one sample, prepared and analyzed within the same preparation batch.
- 15.1.4. Instrument Method – is a file generated to contain the instrument calibration and instrument parameter settings for a particular analysis.
- 15.1.5. Instrument Blank – is a target-analyte-free solvent subjected to the entire analytical process to establish zero baseline or background value.
- 15.1.6. Lab Control Sample (LCS) – is a target-analyte-free sample spiked with a verified known amount of target analyte(s) or a reference material with a certified known value subjected to the entire sample preparation and/or analytical process. LCS is analyzed to monitor the accuracy of the analytical system.
- 15.1.7. Matrix – is a component or form of a sample.
- 15.1.8. Matrix Spike (MS) – is a sample spiked with a verified known amount of target analyte(s) subjected to the entire sample preparation and/or analytical process. MS is analyzed to monitor matrix effect on a method's recovery efficiency.
- 15.1.9. Matrix Spike Duplicate (MSD) – is a replicate of MS analyzed to monitor precision or recovery.
- 15.1.10. Method Blank – is a target-analyte-free sample subjected to the entire sample preparation and/or analytical to monitor contamination.

## STANDARD OPERATING PROCEDURES

**GASOLINE RANGE ORGANICS**

SOP No.: EMAX-8015G Revision No. 5 Effective Date: 24-Jan-14

---

15.1.11. Sample – is a specimen received in the laboratory bearing a sample label traceable to the accompanying COC. Samples collected in different containers having the same field sample ID are considered the same and therefore labeled with the same lab sample ID unless otherwise specified by the project.

15.1.12. Sub-sample – is an aliquot taken from a sample for analysis. Each sub-sample is uniquely identified by the sample preparation ID.

**15.2. Application of EMAX QC Procedures**

15.2.1. The procedures and QC criteria summarized in this SOP shall be applied to all projects when performing gasoline range organics unless otherwise other directive is specified by the project requirements.

**15.3. Department of Defense (DoD) and Department of Energy (DOE) Projects**

15.3.1. Samples from DoD and DOE sponsored projects shall follow the Quality Assurance Project Plan (QAPP), Statement of Work (SOW) and/or client's quality control directive. In the absence of QAPP, the DoD Quality Systems Manual (QSM), latest update, shall be applied

**16.0 REFERENCES**

- 16.1. US EPA SW846 Method 8015C, Revision 3, February 2007.
- 16.2. US EPA SW846 Method 8015D, Revision 4, June 2003.
- 16.3. US EPA SW846 Method 8015B, Revision 2, December 1996.
- 16.4. US EPA SW846 Method 8000B, Revision 2, December 1996.
- 16.5. EMAX Quality Systems Manual, as updated.

**17.0 APPENDICES****17.1. Figures**

- |          |           |  |
|----------|-----------|--|
| 17.1.1.  | Figure 1  | Typical Peak Evaluation                  |
| 17.1.2.  | Figure 2  | Typical GRO Chromatogram                 |
| 17.1.3.  | Figure 3  | Typical Hydrocarbon Marker Chromatograms |
| 17.1.4.  | Figure 4  | Typical ICAL Summary                     |
| 17.1.5.  | Figure 5  | Typical Continuing Calibration Summary   |
| 17.1.6.  | Figure 6  | Typical Raw Data                         |
| 17.1.7.  | Figure 7  | Typical Sample Result Summary            |
| 17.1.8.  | Figure 8  | Typical LCS/LCSD Summary                 |
| 17.1.9.  | Figure 9  | Typical MS/MSD Summary                   |
| 17.1.10. | Figure 10 | Typical Case Narrative                   |

**17.2. Appendices**

- |         |            |                                       |
|---------|------------|---------------------------------------|
| 17.2.1. | Appendix 1 | Summary of Quality Control Procedures |
|---------|------------|---------------------------------------|

## STANDARD OPERATING PROCEDURES

**GASOLINE RANGE ORGANICS**

SOP No.: EMAX-8015G Revision No. 5 Effective Date: 24-Jan-14

---

17.2.2. Appendix 2 Demonstration of Capability

**17.3 Forms**

17.3.1 8015GFS Sample Preparation Log

17.3.1 8015GFA Analytical Run Log

17.3.2 8015GFM Instrument Maintenance Log

**Figure 1:** **TYPICAL PEAK EVALUATION**

---

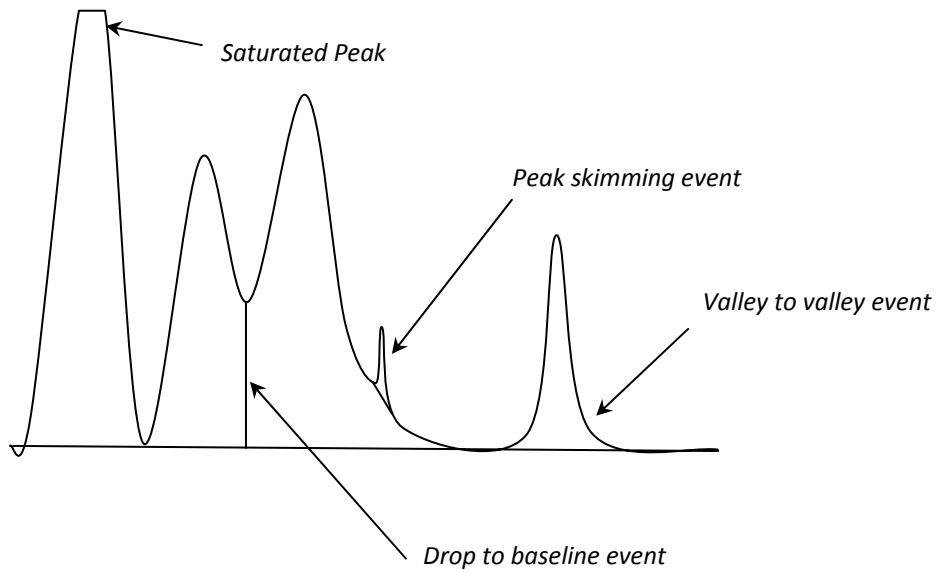

**Figure 2: TYPICAL CHROMATOGRAM**

EPA METHOD 8015 by FID  
 EMAx Analytical Laboratories, Inc.

File : c:\ezchrom\chrom\ea03\ea03.010  
 Method : c:\ezchrom\methods\vg39a03.met  
 Sample ID : IVG39A0302 500/40  
 Acquired : Jan 03, 2014 21:37:01  
 Printed : Jan 06, 2014 12:19:37  
 User : SERGIO

Channel A Results

| #  | Peak Name          | Ret. Time (Min) | Area       | Ave. CF | ESTD Conc. (PPB) |
|----|--------------------|-----------------|------------|---------|------------------|
| 15 | 1,1,1-TFT          | 3.125           | 984381.0   | 22722.0 | 43.32            |
| 41 | Bromofluorobenzene | 10.675          | 788502.0   | 17848.0 | 44.18            |
| G1 | GASOLINE (TOTAL)   |                 | 14063293.0 | 27233.2 | 516.40           |
| G2 | GRO (C6-C10)       |                 | 9336308.0  | 20606.5 | 453.08           |
| G3 | GRO (2MP-124TMB)   |                 | 9284983.0  | 20571.2 | 451.36           |
| G4 | GRO (C5-C12)       |                 | 13063346.0 | 26615.6 | 490.81           |
| G5 | GRO (C6-C12)       |                 | 13013487.0 | 26585.6 | 489.49           |
| G6 | GRO (C5-C10)       |                 | 9386167.0  | 20636.5 | 454.83           |

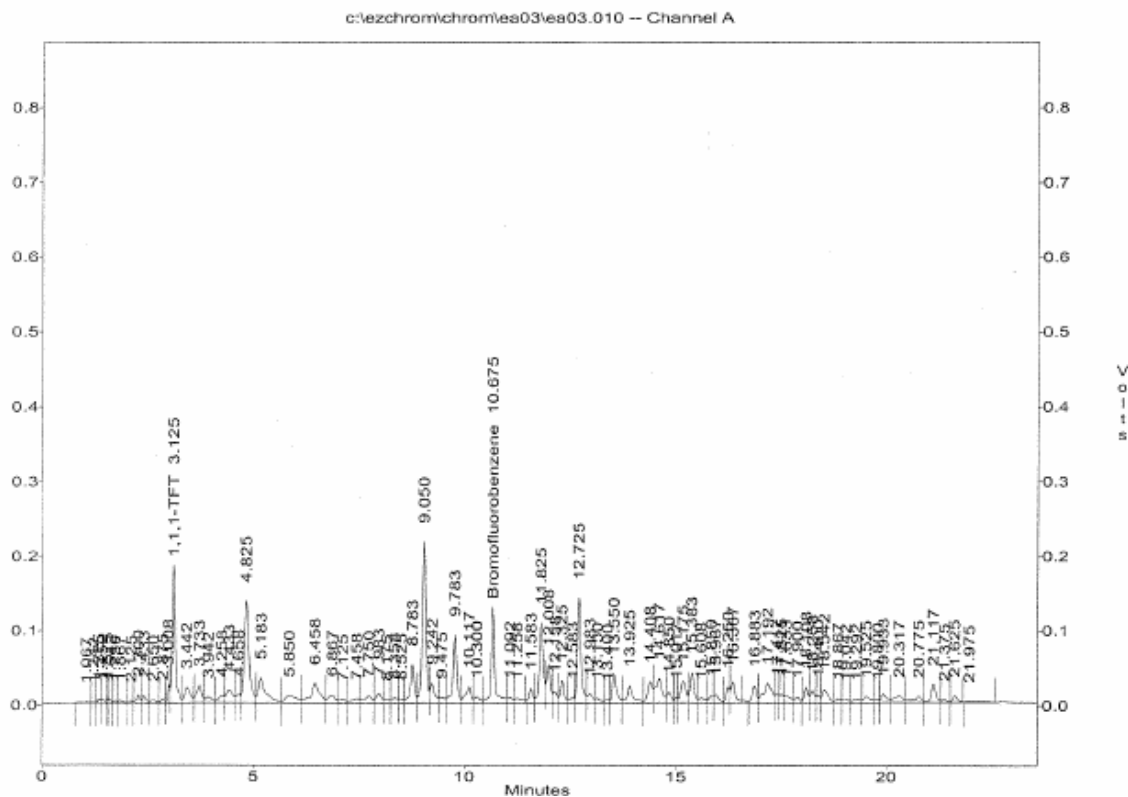

### Figure 3: TYPICAL HYDROCARBON MARKER CHROMATOGRAMS

Page 1 of 1

EPA METHOD 8015 by FID  
EMAX Analytical Laboratories, Inc.

File : c:\ezchrom\chrom\ea03\ea03.013  
Method : c:\ezchrom\methods\vg39a03.met  
Sample ID : GRO 1UL  
Acquired : Jan 03, 2014 23:32:32  
Printed : Jan 06, 2014 12:23:28  
User : SERGIO

#### Channel A Results

| #  | Peak Name          | Ret.Time (Min) | Area       | Ave. CF | ESTD Conc. (PPB) |
|----|--------------------|----------------|------------|---------|------------------|
| -- | 1,1,1-TFT          | 3.150          | 0.0        | 0.0     | 0.00             |
| -- | Bromofluorobenzene | 10.700         | 0.0        | 0.0     | 0.00             |
| G1 | GASOLINE (TOTAL)   |                | 29925396.0 | 27233.2 | 1098.86          |
| G2 | GRO (C6-C10)       |                | 21311152.0 | 20606.5 | 1034.20          |
| G3 | GRO (2MP-124TMB)   |                | 21311152.0 | 20571.2 | 1035.97          |
| G4 | GRO (C5-C12)       |                | 29925396.0 | 26615.6 | 1124.35          |
| G5 | GRO (C6-C12)       |                | 29925396.0 | 26585.6 | 1125.62          |
| G6 | GRO (C5-C10)       |                | 21311152.0 | 20636.5 | 1032.69          |

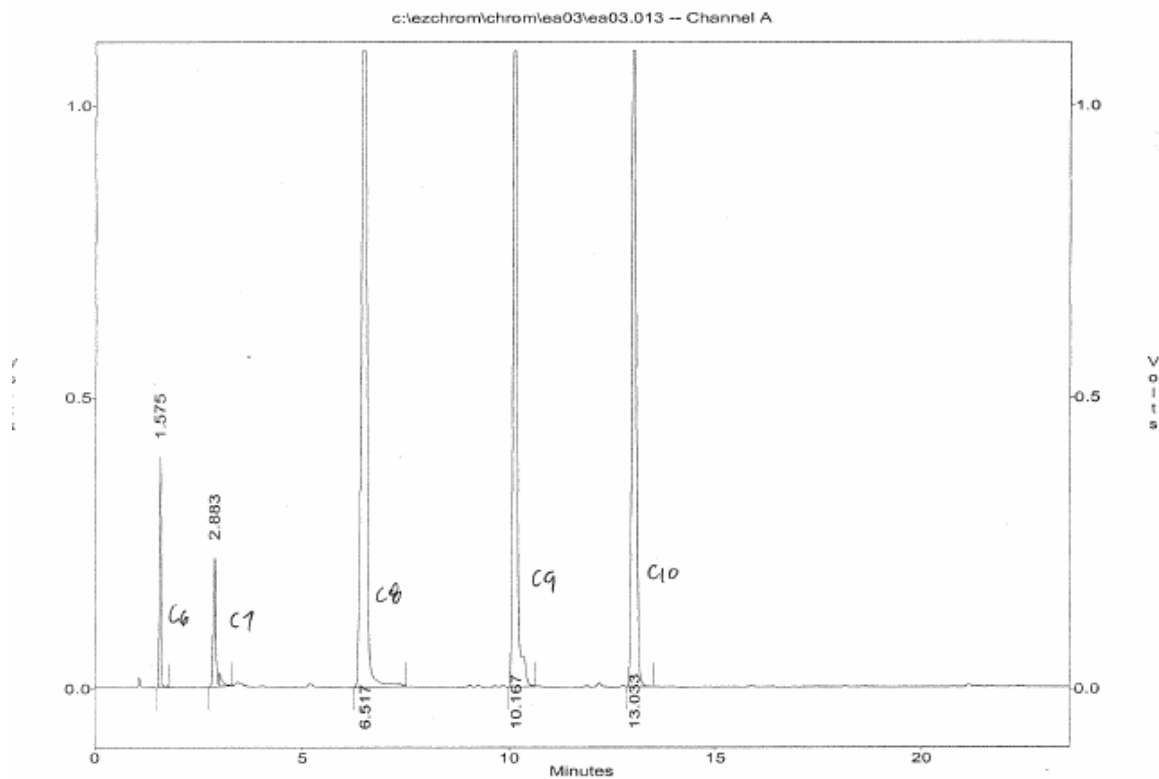

**Figure 3: TYPICAL HYDROCARBON MARKER CHROMATOGRAMS (continuation)**

Page 1 of 1

EPA METHOD 8015 by FID  
 EMAX Analytical Laboratories, Inc.

File : c:\ezchrom\chrom\ea03\ea03.014  
 Method : c:\ezchrom\methods\vg39a03.met  
 Sample ID : 2MP/1,2,4-TMB  
 Acquired : Jan 04, 2014 00:11:01  
 Printed : Jan 06, 2014 12:22:38  
 User : SERGIO

Channel A Results

| #  | Peak Name          | Ret. Time (Min) | Area       | Ave. CF | ESTD Conc. (PPB) |
|----|--------------------|-----------------|------------|---------|------------------|
| -- | 1,1,1-TFT          | 3.150           | 0.0        | 0.0     | 0.00             |
| -- | Bromofluorobenzene | 10.700          | 0.0        | 0.0     | 0.00             |
| G1 | GASOLINE (TOTAL)   |                 | 14307337.0 | 27233.2 | 525.36           |
| G2 | GRO (C6-C10)       |                 | 9312826.0  | 20606.5 | 451.94           |
| G3 | GRO (2MP-124TMB)   |                 | 0.0        | 20571.2 | 0.00             |
| G4 | GRO (C5-C12)       |                 | 14304282.0 | 26615.6 | 537.44           |
| G5 | GRO (C6-C12)       |                 | 9312826.0  | 26585.6 | 350.30           |
| G6 | GRO (C5-C10)       |                 | 14304282.0 | 20636.5 | 693.15           |

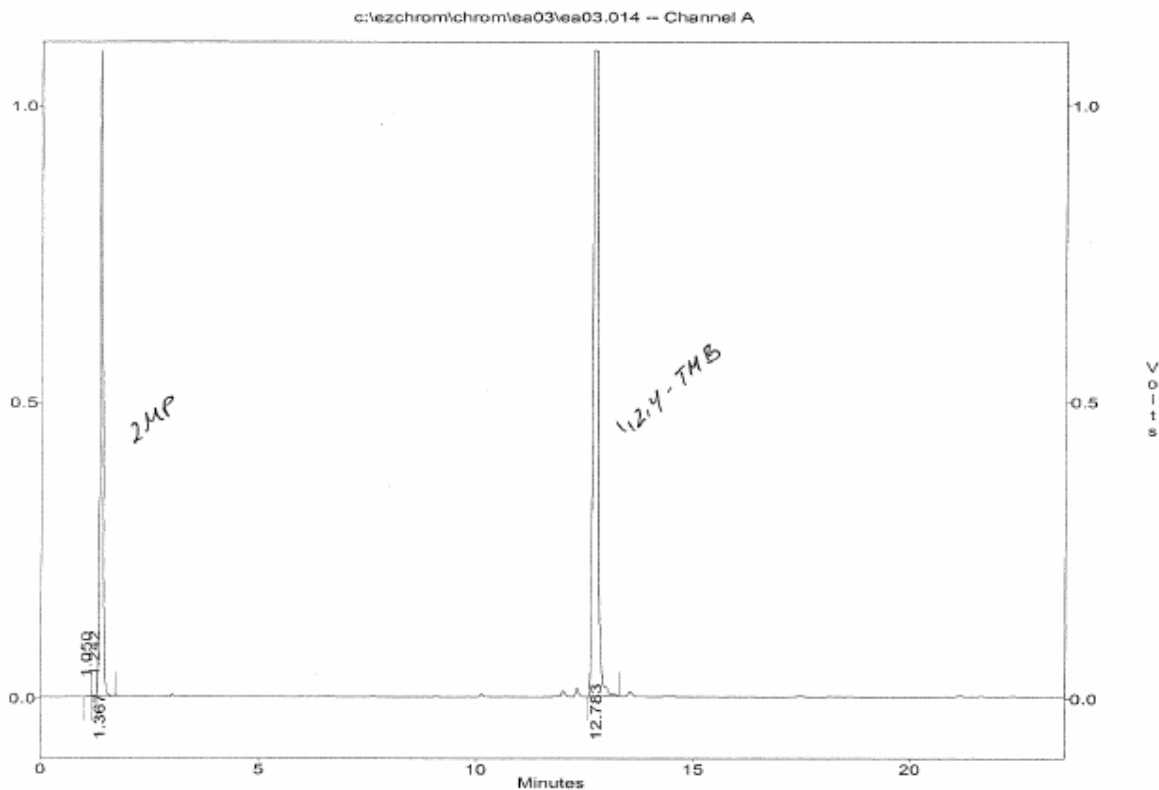



**Figure 3: TYPICAL HYDROCARBON MARKER CHROMATOGRAMS (continuation)**

Page 1 of 1

EPA METHOD 8015 by FID  
 EMAX Analytical Laboratories, Inc.

File : c:\ezchrom\chrom\ea03\ea03.015  
 Method : c:\ezchrom\methods\vg39a03.met  
 Sample ID : PENTANE/NAPHTHALENE  
 Acquired : Jan 04, 2014 00:49:28  
 Printed : Jan 06, 2014 12:22:47  
 User : SERGIO

Channel A Results

| #  | Peak Name          | Ret.Time (Min) | Area       | Ave. CF | ESTD Conc. (PPB) |
|----|--------------------|----------------|------------|---------|------------------|
| -- | 1,1,1-TFT          | 3.150          | 0.0        | 0.0     | 0.00             |
| -- | Bromofluorobenzene | 10.700         | 0.0        | 0.0     | 0.00             |
| G1 | GASOLINE (TOTAL)   |                | 17371524.0 | 27233.2 | 637.88           |
| G2 | GRO (C6-C10)       |                | 0.0        | 20606.5 | 0.00             |
| G3 | GRO (2MP-124TMB)   |                | 0.0        | 20571.2 | 0.00             |
| G4 | GRO (C5-C12)       |                | 17347616.0 | 26615.6 | 651.78           |
| G5 | GRO (C6-C12)       |                | 7450149.0  | 26585.6 | 280.23           |
| G6 | GRO (C5-C10)       |                | 9897466.0  | 20636.5 | 479.61           |

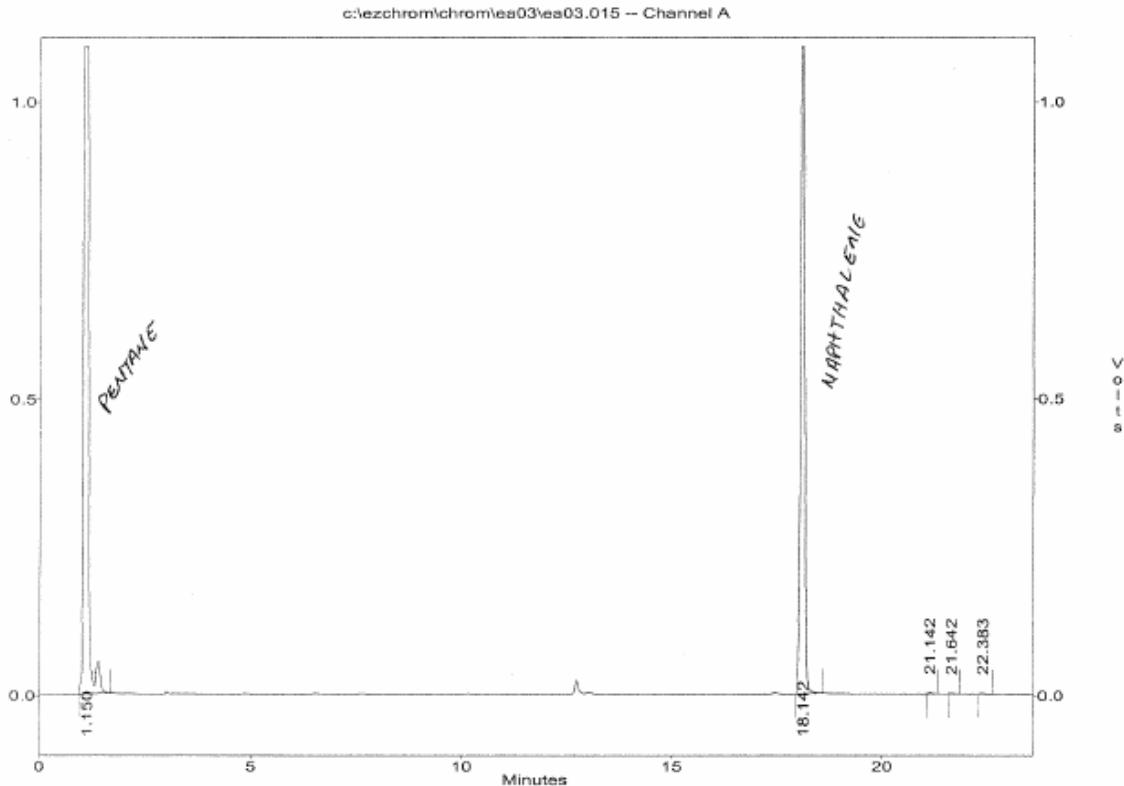

**Figure 3: TYPICAL HYDROCARBON MARKER CHROMATOGRAMS (continuation)**

Page 1 of 1

EPA METHOD 8015 by FID  
 EMAX Analytical Laboratories, Inc.

File : c:\ezchrom\chrom\ea03\ea03.016  
 Method : c:\ezchrom\methods\vg39a03.met  
 Sample ID : UNDECANE/DODECANE  
 Acquired : Jan 04, 2014 01:27:55  
 Printed : Jan 06, 2014 12:23:00  
 User : SERGIO

Channel A Results

| #  | Peak Name          | Ret.Time (Min) | Area      | Ave. CF | ESTD Conc. (PPB) |
|----|--------------------|----------------|-----------|---------|------------------|
| -- | 1,1,1-TFT          | 3.150          | 0.0       | 0.0     | 0.00             |
| -- | Bromofluorobenzene | 10.700         | 0.0       | 0.0     | 0.00             |
| G1 | GASOLINE (TOTAL)   |                | 7098382.0 | 27233.2 | 260.65           |
| G2 | GRO (C6-C10)       |                | 0.0       | 20606.5 | 0.00             |
| G3 | GRO (2MP-124TMB)   |                | 0.0       | 20571.2 | 0.00             |
| G4 | GRO (C5-C12)       |                | 6837192.0 | 26615.6 | 256.89           |
| G5 | GRO (C6-C12)       |                | 6837192.0 | 26585.6 | 257.18           |
| G6 | GRO (C5-C10)       |                | 0.0       | 20636.5 | 0.00             |

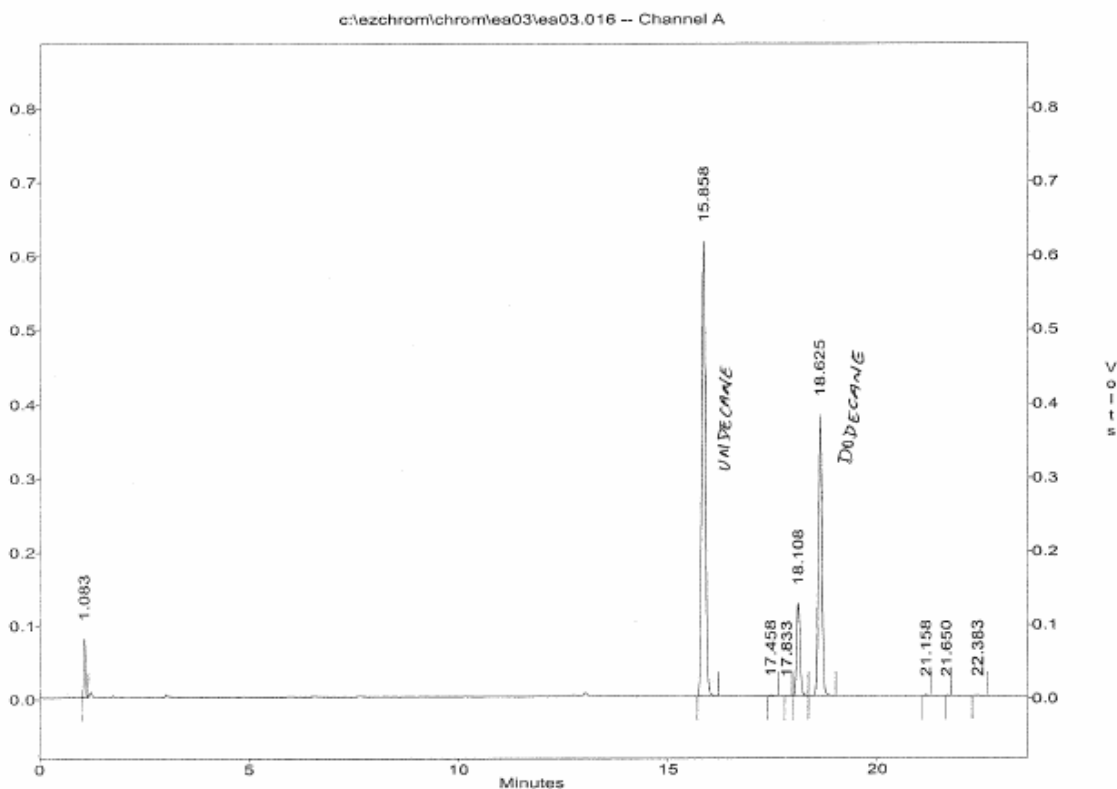

**Figure 4: TYPICAL ICAL SUMMARY**

INITIAL CALIBRATION  
5030B/M8015

Lab Name : EMAX Inc  
Instrument ID : GCT39  
GC Column : DB-5  
Column size ID : 30MX.53MM  
LFID & Datetime: EA03003A 01/03/14 17:08  
LFID & Datetime: EA03004A 01/03/14 17:46  
LFID & Datetime: EA03005A 01/03/14 18:25  
LFID & Datetime: EA03006A 01/03/14 19:03  
LFID & Datetime: EA03007A 01/03/14 19:41  
LFID & Datetime: EA03008A 01/03/14 20:20  
CONC UNIT: ppb

| COMPOUND               | CONC<br>X | CALIBRATION FACTORS |       |       |        |        | (AREA)/UNIT |         | MEAN | %RSD |
|------------------------|-----------|---------------------|-------|-------|--------|--------|-------------|---------|------|------|
|                        |           | 1.00X               | 2.50X | 5.00X | 25.00X | 50.00X | 75.00X      |         |      |      |
| Gasoline(TOTAL)        | 20.00     | 24652               | 27578 | 27219 | 29767  | 26888  | 27295       | 27233.2 | 6.0  |      |
| GRO(C6-C10)            | 20.00     | 18461               | 21683 | 20770 | 21960  | 20286  | 20480       | 20606.5 | 6.0  |      |
| GRO(2MP-124TMB)        | 20.00     | 18461               | 21683 | 20770 | 21865  | 20227  | 20422       | 20571.2 | 6.0  |      |
| GRO(C5-C12)            | 20.00     | 23119               | 27187 | 26894 | 29198  | 26465  | 26832       | 26615.6 | 7.4  |      |
| GRO(C6-C12)            | 20.00     | 23022               | 27147 | 26869 | 29193  | 26457  | 26826       | 26585.6 | 7.5  |      |
| GRO(C5-C10)            | 20.00     | 18558               | 21723 | 20794 | 21964  | 20294  | 20486       | 20636.5 | 5.9  |      |
| SURROGATE              | X         | 1.00X               | 2.00X | 3.00X | 4.00X  | 5.00X  | 6.00X       | MEAN    | %RSD |      |
| Bromofluorobenzene     | 10.00     | 15758               | 16495 | 16129 | 20469  | 18793  | 19444       | 17848.0 | 11.1 |      |
| 1,1,1-Trifluorotoluene | 10.00     | 22945               | 22299 | 21809 | 22278  | 23050  | 23951       | 22722.0 | 3.3  |      |

VG39A03.MET

INITIAL CALIBRATION  
5030B/M8015

Lab Name : EMAX Inc  
Instrument ID : GCT39  
GC Column : DB-5  
Column size ID : 30MX.53MM  
LFID & Datetime: EA03003A 01/03/14 17:08  
LFID & Datetime: EA03004A 01/03/14 17:46  
LFID & Datetime: EA03005A 01/03/14 18:25  
LFID & Datetime: EA03006A 01/03/14 19:03  
LFID & Datetime: EA03007A 01/03/14 19:41  
LFID & Datetime: EA03008A 01/03/14 20:20

| COMPOUND               | RT OF STANDARDS (MIN) |        |        |        |        |        | MEAN<br>RT | RT WINDOW |        | RTWINDOW<br>WIDTH |
|------------------------|-----------------------|--------|--------|--------|--------|--------|------------|-----------|--------|-------------------|
|                        | 1.0X                  | 2.5X   | 5.0X   | 25.0X  | 50.0X  | 75.0X  |            | FROM      | TO     |                   |
| Gasoline(TOTAL)        | NA                    | NA     | NA     | NA     | NA     | NA     | NA         | NA        | NA     | NA                |
| GRO(C6-C10)            | NA                    | NA     | NA     | NA     | NA     | NA     | NA         | NA        | NA     | NA                |
| GRO(2MP-124TMB)        | NA                    | NA     | NA     | NA     | NA     | NA     | NA         | NA        | NA     | NA                |
| GRO(C5-C12)            | NA                    | NA     | NA     | NA     | NA     | NA     | NA         | NA        | NA     | NA                |
| GRO(C6-C12)            | NA                    | NA     | NA     | NA     | NA     | NA     | NA         | NA        | NA     | NA                |
| GRO(C5-C10)            | NA                    | NA     | NA     | NA     | NA     | NA     | NA         | NA        | NA     | NA                |
| SURROGATE              | 1.0X                  | 2.0X   | 3.0X   | 4.0X   | 5.0X   | 6.0X   | RT         | FROM      | TO     | WIDTH             |
| Bromofluorobenzene     | 10.700                | 10.683 | 10.683 | 10.675 | 10.675 | 10.675 | 10.682     | 10.639    | 10.725 | 0.043             |
| 1,1,1-Trifluorotoluene | 3.192                 | 3.158  | 3.167  | 3.117  | 3.125  | 3.125  | 3.147      | 3.023     | 3.271  | 0.124             |

VG39A03.MET

**Figure 5: TYPICAL CONTINUING CALIBRATION SUMMARY**

CONTINUE CALIBRATION  
 5030B/M8015

Lab Name : EMAX Inc  
 Instrument ID : GCT39  
 GC Column : DB-5  
 Column size ID : 30MX.53MM  
 Mid Conc Init LFID & Datetime: EA03006A 01/03/2014 19:03  
 Conc Cont LFID & Datetime: EA09003A 01/09/2014 13:25  
 CONC UNIT : ppb

| COMPOUND               | RT<br>MINUTES | RT WINDOW |        | TRUE<br>CONC | AVERAGE<br>CF | RESULT   |        |    | QL | %D<br>LIMITS |
|------------------------|---------------|-----------|--------|--------------|---------------|----------|--------|----|----|--------------|
|                        |               | FROM      | TO     |              |               | AREA     | CONC   | %D |    |              |
| Gasoline(TOTAL)        | NA            | NA        | NA     | 500.0        | 27233.2       | 13446054 | 493.74 | -1 |    | 20           |
| GRO(C6-C10)            | NA            | NA        | NA     | 500.0        | 20606.5       | 10381184 | 503.78 | 1  |    | 20           |
| GRO(2MP-124TMB)        | NA            | NA        | NA     | 500.0        | 20571.2       | 10231844 | 497.39 | -1 |    | 20           |
| GRO(C5-C12)            | NA            | NA        | NA     | 500.0        | 26615.6       | 13343700 | 501.35 | 0  |    | 20           |
| GRO(C6-C12)            | NA            | NA        | NA     | 500.0        | 26585.6       | 13342070 | 501.85 | 0  |    | 20           |
| GRO(C5-C10)            | NA            | NA        | NA     | 500.0        | 20636.5       | 10382814 | 503.13 | 1  |    | 20           |
| SURROGATE              | MINUTES       | FROM      | TO     | TRUECON      | CF            | AREA     | CONC   | %D | QL | LIMITS       |
| Bromofluorobenzene     | 10.700        | 10.657    | 10.743 | 40.0         | 17848.0       | 731282   | 40.97  | 2  |    | 20           |
| 1,1,1-Trifluorotoluene | 3.192         | 3.068     | 3.316  | 40.0         | 22722.0       | 921311   | 40.55  | 1  |    | 20           |

### Figure 6: TYPICAL RAW DATA

Page 1 of 1

EPA METHOD 8015 by FID  
EMAX Analytical Laboratories, Inc.

File : c:\ezchrom\chrom\ea09\ea09.009  
Method : c:\ezchrom\methods\vg39a03.met  
Sample ID : 14A018-03 5.0ML W  
Acquired : Jan 09, 2014 17:21:15  
Printed : Jan 24, 2014 11:58:54  
User : SERGIO

#### Channel A Results

| #  | Peak Name          | Ret. Time (Min) | Area     | Ave. CF | ESTD Conc. (PPB) |
|----|--------------------|-----------------|----------|---------|------------------|
| 5  | 1,1,1-TFT          | 3.192           | 908699.0 | 22722.0 | 39.99            |
| 7  | Bromofluorobenzene | 10.700          | 638363.0 | 17848.0 | 35.77            |
| G1 | GASOLINE (TOTAL)   |                 | 221859.0 | 27233.2 | 8.15             |
| G2 | GRO (C6-C10)       |                 | 137610.0 | 20606.5 | 6.68             |
| G3 | GRO (2MP-124TMB)   |                 | 137610.0 | 20571.2 | 6.69             |
| G4 | GRO (C5-C12)       |                 | 212863.0 | 26615.6 | 8.00             |
| G5 | GRO (C6-C12)       |                 | 209157.0 | 26585.6 | 7.87             |
| G6 | GRO (C5-C10)       |                 | 141316.0 | 20636.5 | 6.85             |

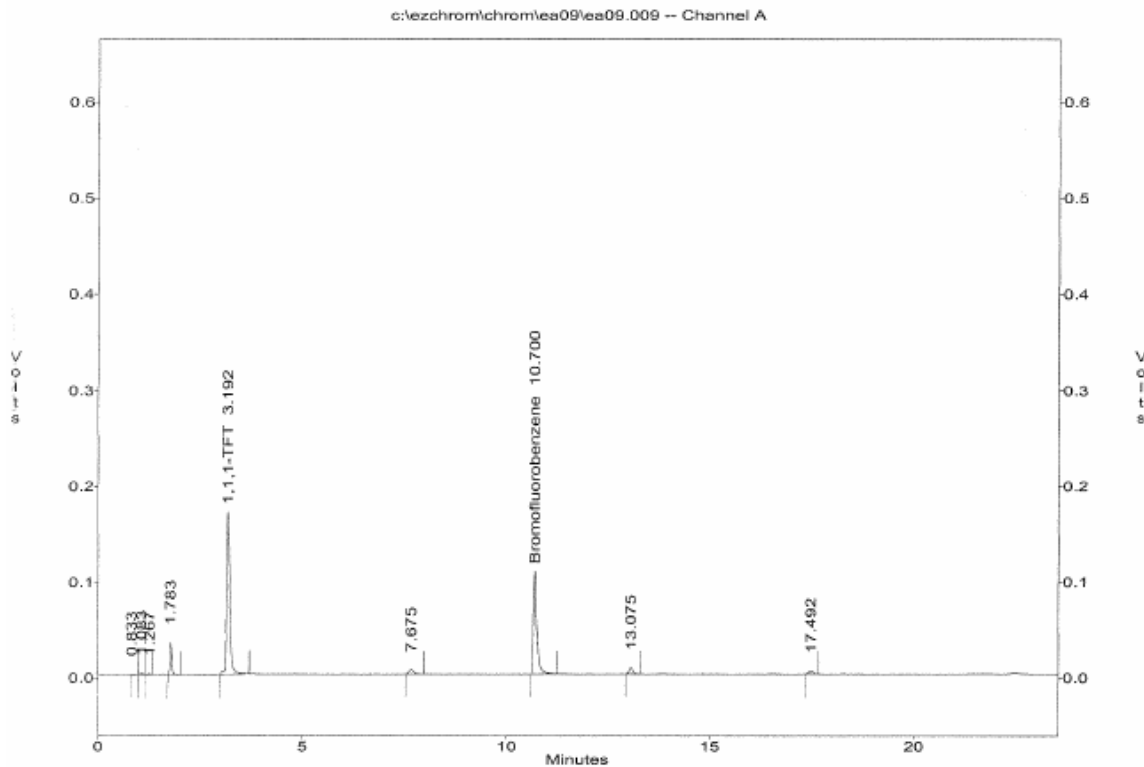

**Figure 7: TYPICAL SAMPLE RESULT SUMMARY**

METHOD 5030B/8015C  
 TOTAL PETROLEUM HYDROCARBONS BY PURGE AND TRAP

```

=====
Client       : XYZ, INC.                Date Collected: 01/07/14
Project      : CLEAN WATER              Date Received: 01/08/14
Batch No.    : 14A018                   Date Extracted: 01/09/14 17:21
Sample ID    : A5-Mw15-010714          Date Analyzed: 01/09/14 17:21
Lab Samp ID  : A018-03                   Dilution Factor: 1
Lab File ID  : EA09009A                  Matrix          : WATER
Ext Btch ID  : VG39A06                   % Moisture      : NA
Calib. Ref.  : EA09003A                  Instrument ID   : GCT039
=====
  
```

| PARAMETERS           | RESULTS<br>(mg/L) | LOQ<br>(mg/L) | DL<br>(mg/L) | LOD<br>(mg/L) |
|----------------------|-------------------|---------------|--------------|---------------|
| GASOLINE             | 0.0067J           | 0.020         | 0.0050       | 0.010         |
| SURROGATE PARAMETERS | RESULTS           | SPK_AMT       | % RECOVERY   | QC LIMIT      |
| BROMOFLUOROBENZENE   | 0.0358            | 0.04000       | 89.4         | 60-140        |

Parameter      H-C Range  
 Gasoline        C6-C10

Figure 8:

TYPICAL LCS/LCSD SUMMARY

EMAX QUALITY CONTROL DATA  
 LCS/LCD ANALYSIS

CLIENT: XYZ, INC.  
 PROJECT: CLEAN WATER  
 BATCH NO.: 14A018  
 METHOD: METHOD 5030B/8015C

=====

MATRIX: WATER % MOISTURE: NA  
 DILUTION FACTOR: 1 1 1  
 SAMPLE ID: MBLK1w  
 LAB SAMP ID: VG39A06B VG39A06L VG39A06C  
 LAB FILE ID: EA09006A EA09004A EA09005A  
 DATE EXTRACTED: 01/09/1415:23 01/09/1414:03 01/09/1414:42 DATE COLLECTED: NA  
 DATE ANALYZED: 01/09/1415:23 01/09/1414:03 01/09/1414:42 DATE RECEIVED: 01/09/14  
 PREP. BATCH: VG39A06 VG39A06 VG39A06  
 CALIB. REF: EA09003A EA09003A EA09003A

ACCESSION:

| PARAMETER | BLNK RSLT (mg/L) | SPIKE AMT (mg/L) | BS RSLT (mg/L) | BS % REC | SPIKE AMT (mg/L) | BSD RSLT (mg/L) | BSD % REC | RPD ( % ) | QC LIMIT ( % ) | MAX RPD ( % ) |
|-----------|------------------|------------------|----------------|----------|------------------|-----------------|-----------|-----------|----------------|---------------|
| Gasoline  | ND               | 0.500            | 0.477          | 95       | 0.500            | 0.459           | 92        | 4         | 60-130         | 30            |

=====

| SURROGATE PARAMETER | SPIKE AMT (mg/L) | BS RSLT (mg/L) | BS % REC | SPIKE AMT (mg/L) | BSD RSLT (mg/L) | BSD % REC | QC LIMIT ( % ) |
|---------------------|------------------|----------------|----------|------------------|-----------------|-----------|----------------|
| Bromofluorobenzene  | 0.0400           | 0.0395         | 99       | 0.0400           | 0.0390          | 97        | 70-130         |

Figure 9:

TYPICAL MS/MSD SUMMARY

EMAX QUALITY CONTROL DATA  
 MS/MSD ANALYSIS

CLIENT: XYZ, INC.  
 PROJECT: CLEAN WATER  
 BATCH NO.: 14A018  
 METHOD: METHOD 5030B/8015C

MATRIX: WATER % MOISTURE: NA  
 DILUTION FACTOR: 1 1 1  
 SAMPLE ID: A5-MW15-010714  
 LAB SAMP ID: A018-03 A018-03M A018-03S  
 LAB FILE ID: EA09009A EA09010A EA09011A  
 DATE EXTRACTED: 01/09/1417:21 01/09/1417:59 01/09/1418:38 DATE COLLECTED: 01/07/14  
 DATE ANALYZED: 01/09/1417:21 01/09/1417:59 01/09/1418:38 DATE RECEIVED: 01/08/14  
 PREP. BATCH: VG39A06 VG39A06 VG39A06  
 CALIB. REF: EA09003A EA09003A EA09003A

ACCESSION:

| PARAMETER | SMPL RSLT<br>(mg/L) | SPIKE AMT<br>(mg/L) | MS RSLT<br>(mg/L) | MS<br>% REC | SPIKE AMT<br>(mg/L) | MSD RSLT<br>(mg/L) | MSD<br>% REC | RPD<br>( % ) | QC LIMIT<br>( % ) | MAX RPD<br>( % ) |
|-----------|---------------------|---------------------|-------------------|-------------|---------------------|--------------------|--------------|--------------|-------------------|------------------|
| Gasoline  | 0.006683            | 0.500               | 0.445             | 88          | 0.500               | 0.465              | 92           | 4            | 50-130            | 30               |

| SURROGATE PARAMETER | SPIKE AMT<br>(mg/L) | MS RSLT<br>(mg/L) | MS<br>% REC | SPIKE AMT<br>(mg/L) | MSD RSLT<br>(mg/L) | MSD<br>% REC | QC LIMIT<br>( % ) |
|---------------------|---------------------|-------------------|-------------|---------------------|--------------------|--------------|-------------------|
| Bromofluorobenzene  | 0.0400              | 0.0390            | 98          | 0.0400              | 0.0392             | 98           | 60-140            |



Figure 10:

TYPICAL CASE NARRATIVE

---

CASE NARRATIVE

Client : XYZ, INC.

Project : CLEAN WATER

SDG : 14A018

METHOD 5030B/8015C  
TOTAL PETROLEUM HYDROCARBONS BY PURGE AND TRAP

A total of ten (10) water samples were received on 01/08/14 for TPH Gasoline analysis, Method 5030B/8015C in accordance with USEPA SW-846, Test Methods for Evaluating Solid Waste, Physical/Chemical Methods.

Holding Time

Samples were analyzed within the prescribed holding time.

Calibration

Multi-calibration points were generated to establish initial calibration (ICAL). ICAL was verified using a secondary source (ICV). Continuing calibration (CCV) verifications were carried on a frequency specified by the project. All calibration requirements were within acceptance criteria. Refer to calibration summary forms of ICAL, ICV and CCV for details.

Method Blank

Method blank was analyzed at the frequency required by the project. For this SDG, one method blank was analyzed with the samples. Result was compliant to project requirement.

Lab Control Sample

A set of LCS/LCD was analyzed with the samples in this SDG. Percent recoveries for VG39A06L/C were all within QC limits.

Matrix QC Sample

A set of MS/MSD was analyzed with the samples in this SDG. Percent recoveries for A018-03M/S were within project QC limits.

Surrogate

Surrogate was added on QC and field samples. Surrogate recoveries were within project QC limits. Refer to sample result forms for details.

Sample Analysis

Samples were analyzed according to prescribed analytical procedures. All project requirements were met; otherwise, anomalies were discussed within the associated QC parameter.

**Appendix 1: SUMMARY OF QUALITY CONTROL PROCEDURES**

| QC Procedure  | Frequency   | Acceptance Criteria                                  | Corrective Action   | 1 <sup>st</sup><br>Rvw | 2 <sup>nd</sup><br>Rvw |
|---|---|--|---|------------------------|------------------------|
| Five-point initial calibration for all analytes   | Initially; as needed  | ACF RSD: ≤ 20%                                       | Correct the problem then repeat initial calibration   |                        |                        |
| Initial calibration verification (ICV)  | After initial calibration   | Within ± 20% of expected value                       | Correct the problem then repeat initial calibration   |                        |                        |
| Calibration verification (DCC)  | Every 12 hours of analysis time and at the end of analysis sequence | Within ± 20% of expected value                       | Correct the problem then repeat initial calibration verification and reanalyze all samples since last successful calibration verification   |                        |                        |
| Method blank  | One per preparation batch   | No analytes detected ≥ ½ LOQ                         | If sample results are ND or contamination is < 10X of sample result, consult with the PM if results are reportable. Otherwise, determine the source of contamination and correct the problem. Reanalyze method blank and all samples processed with the contaminated blank. If re-analysis is not possible, apply B to specific analyte(s) on all associated. |                        |                        |
| LCS   | One LCS per preparation batch                                       | Within project QC Limits                             | Re-prep and reanalyze the LCS and all associated samples  |                        |                        |
| Surrogate spike   | Every sample, spiked sample, standard, and method blank             | Within project QC Limits                             | If no apparent matrix interference is observed, reanalyze the sample. Otherwise inform the PM for further instruction.  |                        |                        |
| MS/MSD  | One MS/MSD per every 20 project samples per matrix                  | Refer to project QC Limits                           | Ensure that spike concentration, spike addition was accurate and calculation is correct. If chromatogram exhibits matrix interference narrate observation in the case narrative.  |                        |                        |
| Chromatogram  | All sample results  | Within calibration range<br><br>No saturated peak(s) | Dilute and re-analyze all samples over the calibration range<br><br>Diluted and re-analyzed all samples demonstrating saturated peak(s) even if the total integrated peaks do not exceed the calibration range.   |                        |                        |
| Notes: Discrete peaks are included for GRO<br><br>Discrete peaks are subtracted for Gasoline<br><br>Refer to PSR for flagging criteria. Report results between LOD and LOQ. |   |  |   | Reviewed By            |                        |
|   |   |  |   | Date                   |                        |

**Appendix 2:**

**DEMONSTRATION OF CAPABILITY**

**DEMONSTRATION OF CAPABILITY  
 GASOLINE RANGE ORGANICS  
 METHOD: SW 8015C**

SOP: EMAX-8015G  
 Conc Unit: µg/L  
 Sample Amount(ml): 5

Instrument ID: 39  
 Analysis date: 1/6/2014  
 Analyzed by: Cervantes, Sergio

| PARAMETER              | EA06004A | EA06005A | EA06006A | EA06007A | TV  | Ave. Conc. | Ave. %Rec | SD   | RSD (%) | QC Criteria | COMMENTS |
|------------------------|----------|----------|----------|----------|-----|------------|-----------|------|---------|-------------|----------|
|                        | VG39A01L | VG39A01C | VG39A02L | VG39A02C |     |            |           |      |         |             |          |
| Gasoline(TOTAL)        | 458      | 485      | 447      | 426      | 500 | 454        | 91        | 24.5 | 5       | 70 - 130    | PASSED   |
| GRO(C6-C10)            | 503      | 540      | 501      | 477      | 500 | 505        | 101       | 25.8 | 5       | 70 - 130    | PASSED   |
| GRO(2MP-124TMB)        | 504      | 542      | 503      | 480      | 500 | 507        | 101       | 25.4 | 5       | 70 - 130    | PASSED   |
| GRO(C5-C12)            | 461      | 490      | 453      | 432      | 500 | 459        | 92        | 24.2 | 5       | 70 - 130    | PASSED   |
| Bromofluorobenzene     | 42.3     | 42.8     | 41.7     | 39.4     | 40  | 41.5       | 104       | 1.50 | 4       | 70 - 130    | PASSED   |
| 1,1,1-Trifluorotoluene | 46.4     | 46.3     | 45.6     | 45.6     | 40  | 46.0       | 115       | 0.43 | 1       | 70 - 130    | PASSED   |

SOP: EMAX-8015G  
 Conc Unit: µg/Kg  
 Sample Amount(g): 5

Instrument ID: 39  
 Analysis date: 1/6/2012  
 Analyzed by: Cervantes, Sergio

| PARAMETER              | EA06013A | EA06014A | EA06015A | EA06016A | TV    | Ave. Conc. | Ave. %Rec | SD  | RSD (%) | QC Criteria | COMMENTS |
|------------------------|----------|----------|----------|----------|-------|------------|-----------|-----|---------|-------------|----------|
|                        | GMA001SL | GMA001SC | GMA001SX | GMA001SY |       |            |           |     |         |             |          |
| Gasoline(TOTAL)        | 20480    | 19683    | 20590    | 20124    | 25000 | 20200      | 81        | 409 | 2       | 60 - 130    | PASSED   |
| GRO(C6-C10)            | 22739    | 21724    | 22671    | 22202    | 25000 | 22300      | 89        | 472 | 2       | 60 - 130    | PASSED   |
| GRO(2MP-124TMB)        | 22676    | 21739    | 22618    | 22216    | 25000 | 22300      | 89        | 433 | 2       | 60 - 130    | PASSED   |
| GRO(C5-C12)            | 20651    | 19816    | 20681    | 20251    | 25000 | 20300      | 81        | 406 | 2       | 60 - 130    | PASSED   |
| Bromofluorobenzene     | 2228     | 2109     | 2176     | 2166     | 2000  | 2170       | 109       | 49  | 2       | 70 - 130    | PASSED   |
| 1,1,1-Trifluorotoluene | 2337     | 2246     | 2335     | 2338     | 2000  | 2310       | 116       | 45  | 2       | 70 - 130    | PASSED   |

8015GFS:

SAMPLE PREPARATION LOG



EXTRACTION LOG  
*for*  
 PURGEABLE TPH

Page 1

**Note:** For samples, relevant QCs/Standards extracted,  
 refer to attached extraction sequence.

Book #.: E39-036

Preparation Batch:

Matrix

Comments:

\_\_\_\_\_  
 \_\_\_\_\_  
 \_\_\_\_\_  
 \_\_\_\_\_  
 \_\_\_\_\_

| SOP                                 | Rev. # |
|-------------------------------------|--------|
| <input type="checkbox"/> EMAX-5035  | 3      |
| <input type="checkbox"/> EMAX-AK101 | 2      |
| <input type="checkbox"/> EMAX-      |        |

\_\_\_\_\_  
 \_\_\_\_\_  
 \_\_\_\_\_  
 \_\_\_\_\_  
 \_\_\_\_\_  
 \_\_\_\_\_

| Standards             | ID | Amount Added (ml) |
|-----------------------|----|-------------------|
| Surrogate             |    |                   |
| LCS/MS                |    |                   |
| Methanol              |    |                   |
| Methanol w/ Surrogate |    |                   |
|                       |    |                   |

\_\_\_\_\_  
 \_\_\_\_\_  
 \_\_\_\_\_  
 \_\_\_\_\_

| Reagent     | Lot # / ID |
|-------------|------------|
| Silica Sand |            |
|             |            |
|             |            |

Prepared By: \_\_\_\_\_

Standard Added By: \_\_\_\_\_ Checked By: \_\_\_\_\_

Extract Location: \_\_\_\_\_

Disposal By: \_\_\_\_\_ Disposal Date: \_\_\_\_\_





## STANDARD OPERATING PROCEDURES

**ORGANOCHLORINE PESTICIDES BY GAS CHROMATOGRAPHY**

SOP No.: EMAX-8081 Revision No. 8 Effective Date: 16-Jun-14

Prepared By: Tu Nisamaneepong *Tu Nisamaneepong* Date: 06-16-14

Approved By: Kenette Pimentel *Kenette Pimentel* Date: 06-16-14  
QA Manager

Approved By: Caspar Pang *Caspar Pang* Date: 06-16-14  
Laboratory Director

Control Number: 8081-08-

**1.0 SCOPE AND APPLICATION**

- 1.1. This procedure is used to determine the concentration of various Organochlorine Pesticides in soil, sediment, sludge, and wastewater samples by gas chromatography method. This SOP is an adaptation of EPA 8081B. Since EPA 8081B is an update and enhancement of EPA 8081A, this SOP is also applicable to EPA 8081A.

**2.0 SUMMARY OF METHOD**

- 2.1. This method provides gas chromatographic conditions for the identification and quantitation of Organochlorine Pesticides with dual Electron Capture Detectors (ECD). The samples are extracted in methylene chloride and exchanged to hexane before GC analysis.
- 2.2. **Interferences**
- 2.2.1. Interferences by phthalate esters introduced during sample preparation can pose a major problem in pesticide determinations. Avoiding contact with any plastic materials and checking all solvents for phthalate contamination can minimize interferences. Glassware must be scrupulously cleaned.
- 2.2.2. The presence of elemental sulfur will result in broad peaks that interfere with the detection of early-eluting organochlorine pesticides. Sulfur contamination is most likely present in sediment samples. The TBA procedure, GPC or other cleanup technique can be used for sulfur removal.
- 2.2.3. Other interferences such as aliphatic compounds, aromatics and nitrogen-containing compounds may be eliminated by using Florisil cleanup.

**3.0 DETECTION LIMITS****3.1. Detection Limit (DL), Limit of Detection (LOD) & Limit of Quantitation (LOQ)**

- 3.1.1. Refer to EMAX-QA04 for generation, validation and verification for DL, LOD and LOQ.
- 3.1.2. Table 10 lists the DL, LOD and LOQ values of the target analytes of this method.

**4.0 DYNAMIC RANGE**

- 4.1. The highest quantifiable concentration requiring no dilution is equal to the highest calibration point. All samples analyzed above this concentration are considered "over-range" and shall require dilution for proper quantitation.

## STANDARD OPERATING PROCEDURE

**ORGANOCHLORINE PESTICIDES BY GAS CHROMATOGRAPHY**SOP No.: EMAX-8081 Revision No. 8 Effective Date: 16-Jun-14

- 4.2. Likewise, the lowest quantifiable concentration of diluted samples is equal to the lowest calibration point. All diluted samples analyzed below this concentration are considered "under-range". A lower dilution factor is required for proper quantitation.
- 4.3. The linear dynamic range for this method as determined in this SOP is listed on the table below.

| Analytes  | Water (µg/L) | Soil (µg/Kg) |
|---|--------------|--------------|
| alpha-BHC, Endosulfan I, gamma-BHC, Heptachlor, Aldrin, alpha-Chlordane, beta-BHC, delta-BHC, gamma-Chlordane, Heptachlor Epoxide | 0.1 – 0.8    | 2 – 26       |
| 4,4'-DDD, 4,4'-DDE, 4,4'-DDT, Dieldrin, Endrin, Endosulfan II, Endosulfan Sulfate, Endrin Aldehyde, Endrin Ketone                 | 0.1 – 1.6    | 2 – 52       |
| Methoxychlor  | 1 – 8        | 10– 260      |
| Toxaphene   | 2 – 20       | 50 – 660     |
| Technical Chlordane   | 1 – 15       | 50 – 500     |
| 2,4'-DDD, 2,4'-DDE, 2,4'-DDT, Oxychlordane, cis-Nonachlor, trans-Nonachlor, Mirex   | 0.1 – 0.8    | 2 – 26       |

**5.0 SAMPLE HOLDING TIME AND PRESERVATION****5.1. Holding Time**

- 5.1.1. Extract water and soil samples within 7 and 14 days from date of collection, respectively.
- 5.1.2. Analyze extracts within 40 days after extraction completion date.

**5.2. Preservation**

- 5.2.1. Store samples and extract at  $\leq 6^{\circ}\text{C}$ .

**6.0 ASSOCIATED SOPs**

- 6.1. EMAX-DM01 Data Flow and Review
- 6.2. EMAX-QA04 Detection Limit Study
- 6.3. EMAX-QA08 Corrective Action
- 6.4. EMAX-QC01 Quality Control for Chemicals
- 6.5. EMAX-QC02 Analytical Standard Preparation
- 6.6. EMAX-QC07 Glassware Cleaning
- 6.7. EMAX-SM03 Waste Disposal
- 6.8. EMAX-SM04 Analytical and QC Sample Labeling
- 6.9. EMAX-3520 Extraction, Continuous Liquid/Liquid
- 6.10. EMAX-3550 Extraction, Pulse Sonication
- 6.11. EMAX-3540 Extraction, Soxhlet
- 6.12. EMAX-3620 Cleanup, Florisil



## STANDARD OPERATING PROCEDURE

**ORGANOCHLORINE PESTICIDES BY GAS CHROMATOGRAPHY**SOP No.: EMAX-8081 Revision No. 8 Effective Date: 16-Jun-14

6.13. EMAX-3660 Cleanup, Sulfur

**7.0 SAFETY**

- 7.1. Read all SDS of chemicals listed in this SOP.
- 7.2. ECD contains minute quantity of Radioactive Ni (63). Conduct a wipe test (experienced personnel or manufacturer only) semi-annually or sooner if potential problem is suspected.
- 7.3. Treat all reagents, standards, and samples as potential hazards. Observe the standard laboratory safety procedures. Wear protective gear, i.e., lab coat, safety glasses, and gloves at all times when performing this procedure.
- 7.4. If, for any reason, solvent and/or other reagents get in contact with your skin or any other part of your body, rinse the affected body part thoroughly with copious amounts of tap water. If irritations persist, inform your supervisor immediately so that proper action can be taken.

**8.0 INSTRUMENTS, CHEMICALS, AND REAGENTS****8.1. Instruments and Supplies**

|                   |  |
|-------------------|--|
| Gas Chromatograph | PE Clarus 680  |
| Detector          | Dual Electron Capture Detectors  |
| Column            | RTX CLPEST I (30 m x 0.32 mm x 0.32 $\mu$ m)<br>RTX CLPEST II (30 m x 0.32 mm x 0.25 $\mu$ m)<br>(Alternate columns may be used after verification of performance) |
| Data System       | EZ Chrom Elite   |
| Auto Sampler      | PE Clarus 680 or equivalent  |
| Gas               | ultra-high purity nitrogen<br>Peak Scientific Hydrogen Generator PH-600<br>PE Hydrogen Generator PGX Series 3  |
| Microsyringes     | 10, 25, 100 and 500 $\mu$ l with a 0.006 mm ID needle<br>(Hamilton 702N or equivalent) for dilution purposes   |
| Transfer Pipette  | Pasteur  |

**8.2. Chemicals and Reagents**

|                    |                                     |
|--------------------|-------------------------------------|
| Solvent [GC-grade] | Methylene Chloride, Hexane, Acetone |
|--------------------|-------------------------------------|

**9.0 STANDARDS****9.1. Standard Preparation**

- 9.1.1. Follow procedures for all standard preparations and labeling as described in EMAX-QC02 and EMAX-SM04, respectively.

## STANDARD OPERATING PROCEDURE

**ORGANOCHLORINE PESTICIDES BY GAS CHROMATOGRAPHY**SOP No.: EMAX-8081 Revision No. 8 Effective Date: 16-Jun-14

9.1.2. Other concentration levels may be prepared to meet the data quality objective of a project.

**9.2. Stock Standard**

9.2.1. Purchase Primary Calibration stock standards as certified solutions in one mixture. After opening, transfer the stock standard to an inert amber vial and store with a minimum of headspace.

9.2.2. Purchase a Secondary set of stock standards from a different source to verify the concentration of the first set of standard. Treat the secondary standard similarly as the primary standard.

9.2.3. Purchase LCS/MS, surrogate and performance evaluation standards as certified solutions from various suppliers.

9.2.4. All standards shall be stored at  $\leq 6^{\circ}\text{C}$ .

**9.3. Intermediate Standard**

9.3.1. Prepare intermediate standards as suggested in Table 3 (primary source) and Table 4 (secondary source).

9.3.2. Store all prepared standards in an inert vial with minimum headspace at  $\leq 6^{\circ}\text{C}$ .

**9.4. Initial Calibration Standard (ICAL)**

9.4.1. Prepare five or more calibration standards as suggested in Table 2 from primary intermediate standard (refer to Table 3).

**9.5. Initial Calibration Verification (ICV)**

9.5.1. Prepare ICV at concentration levels suggested in Table 5 using intermediate standard from second source stock standard (refer to Table 4).

**9.6. Daily Calibration Check Standard (DCC)**

9.6.1. Prepare DCC from the same source as the ICAL standard as suggested in Table 5.

**9.7. Surrogate Standard**

9.7.1. Prepare surrogate standard as suggested in Table 6.

**9.8. LCS/MS Spike Standard**

9.8.1. Prepare LCS solution as suggested in Table 4.

9.8.2. Prepare MS spike standard as suggested in Table 7.

**9.9. Performance Evaluation Mixture (PEM)**

9.9.1. Prepare PEM as suggested in Table 8.

**10.0 PROCEDURES****10.1. Sample Preparation**

10.1.1. Prepare aqueous samples as described in EMAX-3520 or EMAX-3510.

10.1.2. Prepare solid samples as described in EMAX-3550, EMAX-3540 or EMAX-3545.

10.1.3. Perform extract clean up (if necessary) as described in EMAX-3620, EMAX-3640 or EMAX-3660, whichever is appropriate.

## STANDARD OPERATING PROCEDURE

**ORGANOCHLORINE PESTICIDES BY GAS CHROMATOGRAPHY**SOP No.: EMAX-8081 Revision No. 8 Effective Date: 16-Jun-14**10.2. Instrument Parameters**

10.2.1. Method 8081A requires an analytical system complete with a temperature programmable gas chromatograph equipped with an autosampler suitable for on column injection of 1 to 5  $\mu$ l.

## 10.2.2. Gas Pressure

N<sub>2</sub> gas line : 60 – 90 psi

H<sub>2</sub> gas line : 60 – 90 psi

10.2.3. Detector Temperature : 305°C (Inst. E8 and F9)

10.2.4. Injector Temperature : 220°C (Inst. E8 & F9)

10.2.5. Make-up Gas Flow : N<sub>2</sub> at 40 mL/min

## 10.2.6. Carrier Gas Flow

For Temperature Program (Inst. F9) : 3.8 mL/min

For Temperature Program (Inst. E8) : See flow program below

| Carrier Gas Ramp | Rate (mL/min) | Setpoint (mL/min) | Hold (min) |
|------------------|---------------|-------------------|------------|
| Initial          | 0             | 2.7               | 5.5        |
| 1                | 2.0           | 4.0               | 20.0       |

## 10.2.7. Oven Temperature Program (Instrument E8)

| Oven Ramp | Rate (°C/min) | Temp (°C) | Hold (min) |
|-----------|---------------|-----------|------------|
| Initial   | 0             | 140       | 0.50       |
| 1         | 25            | 230       | 2.00       |
| 2         | 5             | 260       | 0.20       |
| 3         | 25            | 290       | 2.50       |

## 10.2.8. Oven Temperature Program (Instrument F9)

| Oven Ramp | Rate (°C/min) | Temp (°C) | Hold (min) |
|-----------|---------------|-----------|------------|
| Initial   | 0             | 130       | 0.50       |
| 1         | 25            | 230       | 2.00       |
| 2         | 5             | 260       | 0.20       |
| 3         | 25            | 290       | 3.00       |

**10.3. Calibration****10.3.1. Performance Evaluation Check**

## STANDARD OPERATING PROCEDURE

**ORGANOCHLORINE PESTICIDES BY GAS CHROMATOGRAPHY**SOP No.: EMAX-8081 Revision No. 8 Effective Date: 16-Jun-14

- 
- 
- 10.3.1.1. Analyze instrument blank and a PEM containing DDT and Endrin to monitor the system performance at 12-hour interval prior to performing any calibration.
  - 10.3.1.2. Calculate the breakdown by using Equations 10.6.6 (%B<sub>T</sub>) for DDT and 10.6.7 (%B<sub>E</sub>) for Endrin.
  - 10.3.1.3. Check Appendix 1 for acceptance criteria before proceeding with sample analysis.
  - 10.3.1.4. If system failed to meet the acceptance criteria, refer to Section 12 for corrective action.

**10.3.2. Initial Calibration (ICAL)**

- 10.3.2.1. Perform ICAL if instrument is new, ICV or DCC failed to meet acceptance criteria or after a major instrument repair.
- 10.3.2.2. A minimum of five calibration standards, or as suggested in Table 1, over the concentration range of interest are sequentially injected into the GC. Refer to Table 1 for ICAL concentrations. Peak areas are obtained from each analyte.
- 10.3.2.3. Application of ICAL Curve for Quantitation
  - 10.3.2.3.1. Generate a summary of calibration factors for each analyte at each concentration using Eq-10.6.1. Calculate the Average Calibration Factor (ACF), the Standard Deviation (SD), and the Relative Standard Deviation (RSD) according to, Eq. 10.6.2, Eq. 10.6.3 and Eq. 10.6.4, respectively.
    - If RSD is  $\leq 20\%$  ACF may be applied.
    - Apply Inverse Weighting Factor ( $1/y$  or  $1/y^2$ ;  $y$  being the instrument response) if it is determined to be the best fit for specific analytes. This approach may be applied to any analyte including analyte that has RSD of  $\leq 20\%$  and correlation coefficient of  $\geq 0.995$ .
    - Apply linear least squares regression if past experience or priori knowledge of instrument response is known to be the best fit for specific analytes. This approach may be applied to any analyte including analyte that has RSD of  $\leq 20\%$  and correlation coefficient of  $\geq 0.995$ .
    - It may be appropriate to force the regression through zero for specific analytes<sup>1</sup>. When exercising this option [as included in the data acquisition software], make sure that the origin (0,0) is not included as a calibration point but rather the intercept is set to zero. This option shall only be applied if the curve favors better accuracy of quantitation.
  - 10.3.2.4. Submit summary of ICAL, raw data and manual integration (if any) for secondary review.
  - 10.3.2.5. Refer to Appendix 1 for acceptance criteria. If acceptance criteria are not met refer to Section 12 for corrective action.

**10.3.3. Initial Calibration Verification (ICV)**

- 10.3.3.1. Analyze ICV prepared from another source as described in Section 9.5 to verify the concentrations of the ICAL.

---

<sup>1</sup> SW846 Method 8000B, Section 7.5.3; SW846 Method 8000C, Section 11.5.2.1

## STANDARD OPERATING PROCEDURE

**ORGANOCHLORINE PESTICIDES BY GAS CHROMATOGRAPHY**SOP No.: EMAX-8081 Revision No. 8 Effective Date: 16-Jun-14

10.3.3.2. Calculate the CF and the percent difference (%D) according to Eq-10.6.1 and 10.6.5 respectively. Refer to Appendix 1 for acceptance criteria. If acceptance criteria are not met refer to Section 12 for corrective action.

10.3.4. **Multicomponent Target Analyses**

10.3.4.1. For multicomponent target analytes (Toxaphene), a five-point calibration standard shall be included in initial calibration for pattern recognition and quantitation.

10.3.4.2. Integrate the total response of the chromatogram to obtain the total area. Calculate the calibration factor (CF) by using Equation 10.6.1.

10.3.5. **Daily Calibration Check (DCC)**

10.3.5.1. Analyze DCC at the start of the 12-hour shift prior to sample analysis and close the analytical run with an ending DCC.

10.3.5.2. Calculate the %D by using Equation 10.6.5. Check Appendix 1 for acceptance criteria. If acceptance criteria are not met refer to Section 12 for corrective action.

10.4. **Analysis**

10.4.1. **Analytical Sequence**

10.4.1.1. Following the instrument data acquisition software, prepare the analytical sequence file as suggested below:

- Pesticide Prime – 20/200 ppb pesticide injected at the beginning of analytical sequence if the GC has not been used for a day or more
- IB – instrument blank
- PEM – performance evaluation mixture
- ICAL – initial calibration standards
- ICV or DCC1 – initial calibration verification or continuing calibration standard
- MB – method blank
- LCS – lab control sample
- Samples – up to 12 hours
- DCC2 – continuing calibration standard or ending DCC

10.4.2. **Sample Analysis**

10.4.2.1. Transfer a minimum of 0.5 ml of extract to a 2-ml auto sampler vial (or equivalent) using a Pasteur pipette. Seal the vial with a polypropylene screw cap with PTFE/red silicone rubber septa. Similarly, prepare the analytical standards and QC samples.

10.4.2.2. Introduce sample extract into the GC using direct injection technique (1 to 5  $\mu$ l) after all system quality control criteria have been met.

10.4.2.3. If the response exceeds the linear range of the system, dilute the sample and re-analyze.

10.4.3. **Sample Result Evaluation**

## STANDARD OPERATING PROCEDURE

**ORGANOCHLORINE PESTICIDES BY GAS CHROMATOGRAPHY**

SOP No.: EMAX-8081 Revision No. 8 Effective Date: 16-Jun-14

---

10.4.3.1. Check QC parameters as soon as the data is available.

- ✓ Check LCS recoveries against Appendix 1.
- ✓ Check MB that it is project compliant.
- ✓ Check retention time.
- ✓ Check surrogate recoveries against Appendix 1.
- ✓ Check concentration of target analytes. If the response exceeds the calibration range, dilute and re-analyze the sample until the response falls within the calibration range.
- ✓ If any of the above checkpoints indicate a problem, re-analysis is required. If re-analysis results are the same as the initial result, consult the Supervisor for further action. If results indicate extraction problem, fill-up an NCR and order re-extraction for the affected sample(s).

10.4.3.2. Positive identification is made when a peak falls within the retention time window of a target analyte on both columns established by the standard reference compound.

10.4.3.3. If one column meets the retention time criteria and a retention time shift is suspected on the other column, use the following guideline in reporting the data:

- ✓ Check that the expanded window does not exceed the RTW of the column in control or the established RTW or the CLP RTW (refer to table 7) whichever is greater.
- ✓ If the above condition is met, report the data and include a description of the observation in the case narrative.

10.4.4. **Retention Time Windows**

10.4.4.1. Establishing RTW

- 10.4.4.1.1. Collect at least three Daily Calibration Standards analyzed over a period of 72 hours.
- 10.4.4.1.2. Calculate the Standard Deviation (SD) of absolute retention time obtained for each analyte.
- 10.4.4.1.3. The width of RTW is defined by  $\pm 3X$  SD obtained from 10.4.4.1.2.

10.4.4.2. Evaluating RTW

- 10.4.4.2.1. If the SD is equal to 0.00, default to the previous study until historical data is obtained or use the CLP<sup>1</sup> retention time window (refer to Table 9) which ever is narrower.
- 10.4.4.2.2. For new instruments, in the interim use the CLP retention time window (refer to Table 9) until RTW is obtained for the new instrument parameters condition.

---

<sup>1</sup> CLP-OLM4.2 Table 1 D-79/PEST

## STANDARD OPERATING PROCEDURE

**ORGANOCHLORINE PESTICIDES BY GAS CHROMATOGRAPHY**SOP No.: EMAX-8081 Revision No. 8 Effective Date: 16-Jun-14

## 10.4.4.3. Application of RTW

10.4.4.3.1. Establish the center of absolute retention time for each analyte to include the surrogate(s) from the daily calibration check at the beginning of the analytical shift then apply the established RTW.

10.4.4.3.2. Whenever the observed retention time is outside the established RTW, the analyst is advised to determine the cause and perform necessary corrective action before continuing the analyses.

## 10.4.4.4. Updating RTW

10.4.4.4.1. Re-establish the RTW as described in Section 10.4.4.1 when any of the following conditions occur:

- Yearly RTW update
- Significant shifting is observed (e.g. succeeding calibration checks or LCS are out of RTW)
- Major instrument maintenance (e.g. replacement of detector or column; temperature program change, etc.)

10.4.5. **Manual Integration**

10.4.5.1. Refer to EMAX-DM01 for details of manual integration.

10.4.6. **Dealing with Carryover**

- ✓ Check the sample analyzed after a sample having target analyte concentrations exceeding the calibration range.
- ✓ If there was no target analyte detected as found in the sample that exceeded the calibration range, proceed with data reduction.
- ✓ If there was a target analyte detected as found in the sample following the sample that exceeded the calibration range (for pesticides concentration  $\geq 500/1000/5000$  ppb; for Toxaphene concentration  $\geq 25$  ppm; for chlordane concentration  $\geq 10$  ppm and for PCBs concentration  $\geq 100$  ppm) re-analyze the sample to rule-out carry over. If carry over is confirmed, proceed with data reduction and report the data from re-analysis.

10.5. **Data Reduction**

10.5.1. Check the chromatogram of positively identified peaks.

- ✓ Peaks fall within the established retention time window on both columns.
- ✓ Peaks are sharp and not saturated.
- ✓ Peaks are properly integrated (refer to Figure 1 for Peak Evaluation Techniques).
- ✓ Target analyte peak is present in both columns to confirm positive identification.

10.5.2. Positive identification is confirmed when the identified analyte is present in both columns. The agreement between the quantitative results should be evaluated after the identification is made. Calculate the relative percent difference (RPD) between the two results according to Equation 10.6.10.2.

## STANDARD OPERATING PROCEDURE

**ORGANOCHLORINE PESTICIDES BY GAS CHROMATOGRAPHY**SOP No.: EMAX-8081 Revision No. 8 Effective Date: 16-Jun-14

- 10.5.2.1. If the RPD is less than 40% and the peaks do not indicate any anomalies, report the higher result.
- 10.5.2.2. If the RPD is less than 40% and one of the peaks indicate an anomaly, report the result from the better peak.
- 10.5.2.3. If the RPD is greater than 40%, use professional judgment to select the most appropriate result. If no evidence of any chromatographic interference, report the higher result.

**10.6. Calculations**

- 10.6.1.
- Calculate for Calibration Factor (CF)

$$CF = \frac{R_a}{C_k} \quad \text{Eq.-10.6.1}$$

*where:* $CF$  - is the calibration factor $R_a$  - is the analyte response measured in peak area $C_k$  - is the known concentration of the analyte in  $\mu\text{g/L}$ 

- 10.6.2.
- Calculate for Standard Deviation

$$SD = \sqrt{\frac{\sum_{i=1}^N (x_i - \bar{x})^2}{N - 1}} \quad \text{Eq.-10.6.2}$$

*where:* $SD$  - is the standard deviation $x_i$  - is the result at the  $i$ th measurement $\bar{x}$  - is the mean $N$  - is the number of measurements

- 10.6.3.
- Calculate for Percent Relative Standard Deviation (%RSD)

$$\%RSD = \left[ \frac{SD}{ACF} \right] 100 \quad \text{Eq.-10.6.3}$$

*where:* $\%RSD$  - is the percent relative standard deviation $SD$  - is the standard deviation $ACF$  - is the average calibration factor

- 10.6.4.
- Calculate for Average Calibration Factor (ACF)

$$ACF = \frac{\sum CF}{N} \quad \text{Eq.-10.6.4}$$



## STANDARD OPERATING PROCEDURE

**ORGANOCHLORINE PESTICIDES BY GAS CHROMATOGRAPHY**SOP No.: EMAX-8081 Revision No. 8 Effective Date: 16-Jun-14*where:**ACF* - is the average calibration factor $\sum CF$  - is the summation of the calibration factors*N* - is the number of calibration points**10.6.5. Calculate for Least Square Linear Regression**

$$y = ax + b \quad \text{Eq.-10.5.1.3}$$

*where:**y* = Response factor*x* = Concentration*a* = *x*<sub>1</sub> = slope of the line

$$a = \frac{\sum (x - \bar{x})(y - \bar{y})}{\sum (x - \bar{x})^2}$$

*where:* $\bar{x}$  = Average of amount ratios $\bar{y}$  = Average of response ratios*b* = *x*<sub>0</sub> = intercept of the line

$$b = \bar{y} - a * \bar{x}$$

**10.6.6. Calculate for Inverse Weighting Factor**

$$y = ax + b \quad \text{Eq.-10.5.1.4}$$

*where:**y* = Response Factor*x* = Concentration*a* = *x*<sub>1</sub> = slope of the line

$$a = \frac{\sum [(x - x_a)(y - y_a)]}{\sum (x - x_a)^2}$$

*where:*

$$x_a = \sum [x(1/x)] / \sum (1/x)$$

$$y_a = \sum [y(1/x)] / \sum (1/x) \text{ or}$$

$$x_a = \sum [x(1/x^2)] / \sum (1/x^2)$$

## STANDARD OPERATING PROCEDURE

**ORGANOCHLORINE PESTICIDES BY GAS CHROMATOGRAPHY**SOP No.: EMAX-8081 Revision No. 8 Effective Date: 16-Jun-14

$$y_a = \Sigma \left[ y(1/x^2) / \Sigma (1/x^2) \right]$$

b = x<sub>0</sub> = intercept of the line

$$b = y_a - a * x_a$$

10.6.7. Calculate for Percent Difference for DCC from ACF

$$\%D = \left[ \frac{CF - ACF}{ACF} \right] 100 \quad \text{Eq.-10.6.5}$$

where:

%D - is the % Difference

ACF - is the Average Calibration Factor

CF - is the Calibration Factor of the DCC

10.6.8. Calculate for % Breakdown for DDT (%B<sub>T</sub>).

$$\%B_T = \frac{A_D + A_E}{A_T + A_D + A_E} \quad \text{Eq.-10.6.6}$$

where:

%B<sub>T</sub> - % DDT Breakdown

A<sub>D</sub> - Total area of DDD

A<sub>E</sub> - Total area of DDE

A<sub>T</sub> - Total area of DDT

10.6.9. Calculate for % Breakdown for Endrin (%B<sub>E</sub>)

$$\%B_E = \frac{A_A + A_K}{A_E + A_A + A_K} \quad \text{Eq.-10.6.7}$$

where:

%B<sub>E</sub> - % Endrin Breakdown

A<sub>A</sub> - Total area of Endrin Aldehyde

A<sub>K</sub> - Total area of Endrin Ketone

A<sub>E</sub> - Total area of Endrin

10.6.10. Sample Results10.6.10.1. **Water Samples**

$$C = \left( \frac{R_a}{ACF} \right) \left( \frac{V_e}{S_a} \right) DF \quad \text{Eq.-10.6.8.1}$$

## STANDARD OPERATING PROCEDURE

**ORGANOCHLORINE PESTICIDES BY GAS CHROMATOGRAPHY**SOP No.: EMAX-8081 Revision No. 8 Effective Date: 16-Jun-14*where:* $C$  - Concentration of sample measured in  $\mu\text{g/L}$  $R_a$  - Total response of analyte in peak area $ACF$  - Average response factor measure in ICAL $V_e$  - Volume of extract in ml $S_a$  - Sample amount in ml $DF$  - Dilution factor of sample extract**10.6.10.2. Soil Samples**

$$C = \left( \frac{R_a}{ACF} \right) \left( \frac{V_e}{S_a (\% \text{ Solid})} \right) DF \quad \text{Eq.-10.6.8.2}$$

*where* $C$  - Concentration of analyte to be measured ( $\mu\text{g/kg}$ ) $R_a$  - Total response of analyte in peak area $ACF$  - Average response factor $V_e$  - Volume of extract in ml $S_a$  - Sample Amount in g $\% \text{ Solid} = \frac{100 - \% \text{ moisture}}{100}$  $DF$  - Dilution factor of the sample extract**10.6.11. Multi-peak Compound in Sample (Toxaphene)**

10.6.11.1. Total area is integrated and concentration is determined by equation 10.6.8.1 or 10.6.8.2.

**10.6.12. Accuracy and Precision****10.6.12.1. Percent Recovery**

$$\%R = \frac{C_f - C}{C_s} * 100 \quad \text{Eq.-10.6.10.1}$$

*where:* $\%R$  - percent recovery $C_f$  - concentration found in spiked sample $C$  - concentration of unspiked sample (For LCS,  $C=0$ ) $C_s$  - theoretical concentration of surrogate spike**10.6.12.2. Relative Percent Difference (RPD)**

## STANDARD OPERATING PROCEDURE

**ORGANOCHLORINE PESTICIDES BY GAS CHROMATOGRAPHY**SOP No.: EMAX-8081 Revision No. 8 Effective Date: 16-Jun-14

$$\%RPD = \frac{|C_1 - C_2|}{\left(\frac{C_1 + C_2}{2}\right)} \times 100 \quad \text{Eq.-10.6.10.2}$$

*where:*

%RPD - Relative Percent Difference

C1 - Measured concentration of the first sample aliquot

C2 - Measured concentration of the second sample aliquot

**10.7. Report Generation**

- 10.7.1. Generate the method.txt file using WDB1C.exe.
- 10.7.2. Generate Lab Chronicle using LABCHRN1.exe.
- 10.7.3. Generate sample results using F1NV3C.exe.
- 10.7.4. Generate the QC Summary file using QCV3CN.exe.
- 10.7.5. Generate the case narrative using CN1.exe.
- 10.7.6. Arrange the analysis package in sequence as detailed below using section separators. Attach all raw data to every form generated, to include manual integration(s) and re-analyses.
  - Sample Results
  - LCS Summary
  - MS/MSD Summary
  - DCC Summary
  - ICAL Summary
  - ICV Summary
  - Copy of Analysis Log
  - Copy of Preparation Log

**10.8. Data Review**

- 10.8.1. Perform a 100% data review in accordance to EMAX-DM01 and the Project Specific Requirements (PSR).
  - ✓ Check that all samples required for analysis are performed.
  - ✓ Check that samples are extracted and analyzed within Holding Time.
  - ✓ Check that all calibration requirements are fulfilled.
  - ✓ Check the chromatogram of all positively identified peak(s).
  - ✓ Check surrogate recoveries against required limits.
  - ✓ Check that concentration of target analytes are within calibration range.

If any of the above checkpoints indicate a problem, re-analysis is required.

## STANDARD OPERATING PROCEDURE

**ORGANOCHLORINE PESTICIDES BY GAS CHROMATOGRAPHY**SOP No.: EMAX-8081 Revision No. 8 Effective Date: 16-Jun-14

10.8.2. Review the case narrative and edit as necessary to reflect essential issues not captured by the case narrative generator program.

10.8.3. Submit the analysis package for secondary review.

**10.9. Preventive Maintenance**

10.9.1. Refer to Form 8081FM for daily routine maintenance check points.

10.9.2. Record instrument maintenance performed in the instrument maintenance log. Initial the column corresponding to the date when the instrument was back in control.

10.9.3. Instruments should receive routine preventive maintenance and recorded in instrument-specific maintenance logs. Routine maintenance ensures that all equipment is operating under optimum conditions, thus reducing the possibility of instrument malfunction and consequently affecting data quality. The table below is a list of preventive maintenance activities that are essential to consider in performing this SOP.

| <b>Maintenance Activity</b> | <b>Description</b>   | <b>Frequency</b>               |
|-----------------------------|--|--------------------------------|
| Autosampler Check           | Inspect and clean syringe. Check autosampler response.   | Daily prior to analysis        |
| Verification                | Check instrument parameters to ensure normal operating conditions.<br>Check liner as necessary.<br>Check instrument performance (e.g., daily calibration check, instrument blank, DDT/Endrin breakdown). | Daily prior to analysis        |
| Documentation               | Record maintenance in instrument service logs.   | Daily prior to analysis        |
| Leak Test                   | Perform inlet pressure decay test.   | Every 6 months or as necessary |
| System Cleaning             | Remove dust from fans and vent covers, inspect and clean inlet and detector where applicable.  | Every 6 months or as necessary |
| Check Flow Path Components  | Check and replace the following as necessary: tubing assembly, union, sample probe, and loop.  | Once a year or as necessary    |
| Complete Inspection         | Perform general inspection of the complete system.<br>Inspect autosampler cabling and configuration setting.   | Once a year                    |

**11.0 QUALITY CONTROL****11.1. Preparative Batch**

11.1.1. A preparative batch shall consist of a method blank, LCS, MS/MSD (when required by the project) and a maximum of 20 field samples of similar matrix.

11.1.2. In the absence of MS/MSD, prepare LCS/LCD to check for precision.

## STANDARD OPERATING PROCEDURE

**ORGANOCHLORINE PESTICIDES BY GAS CHROMATOGRAPHY**SOP No.: EMAX-8081 Revision No. 8 Effective Date: 16-Jun-14

11.1.3. Surrogate standard shall be added to all samples, including method blank LCS/LCD and MS/MSD. Check PSR for QC Control Limits.

11.1.4. Perform QC check prior to utilizing the surrogate and LCS/MS spike standards by analyzing the prepared standard at the spiking level. Results should be within  $\pm 20\%$  of the expected value.

**11.2. Analytical Batch QC**

11.2.1. Instrument Performance Evaluation Check must be analyzed daily. Acceptance criteria and corrective action are discussed in Section 10.3.1.4 and Appendix 1.

11.2.2. A continuing calibration shall be performed before any other analysis is done. The continuing calibration procedure and the acceptance criteria are discussed in Section 10.3.5 and Appendix 1.

**11.3. Method QC**

11.3.1. Analyst demonstration of proficiency is a must prior to performing this analysis.

11.3.2. A valid LOD and LOQ must exist prior to sample analysis.

11.3.3. A valid ICAL must exist prior to sample analysis.

11.3.4. Instrument performance must be checked prior to sample analysis. Check Appendix 1 for acceptance criteria.

11.3.5. Prepare and analyze QC samples, to include, method blank, LCS (LCD), and MS/MSD. QC Control Limits shall follow the Project Specific Requirement (PSR) in each analytical folder.

**12.0 CORRECTIVE ACTION**

12.1. Corrective actions associated with this analytical procedure are described in the Summary of In-House Quality Control Procedures in Appendix 1. Document out-of-control event/s and corrective action in the analytical logbook. If the problem persists, consult the supervisor.

12.2. If PEM failed to meet the DDT and Endrin breakdown acceptance criteria, consider the following suggestions to correct the problem:

12.2.1. Deactivate or replace the injection liner.

12.2.2. Check that the injector nut is leak-free.

12.2.3. If problem persists, inform the Supervisor.

12.3. If Initial calibration is non-compliant, consider the following suggestions to correct the problem:

12.3.1. If %RSD is out of acceptance criteria, review result and identify presence of an outlier.

12.3.2. If one of the standard returns a bias-low or bias-high on all of the analytes, then that point is considered an outlier, prepare a standard at that ICAL point and reanalyze.

12.3.3. If the highest ICAL point appears to be saturated, drop the highest point.

12.3.4. If the lowest point returns a bias-low response or the peaks are not distinct and sharp, consider the point not usable.

## STANDARD OPERATING PROCEDURE

**ORGANOCHLORINE PESTICIDES BY GAS CHROMATOGRAPHY**SOP No.: EMAX-8081 Revision No. 8 Effective Date: 16-Jun-14

*Note: The lowest calibration point identifies the reporting limit (RL). Therefore, check that the RL is in conformance to the current projects where the ICAL will be used.*

- 12.3.5. If instrumentation problem is suspected, consider the following suggestions to correct the problem:
  - 12.3.5.1. Check the connections and make sure they are air-tight and perform maintenance as needed.
  - 12.3.5.2. Check the gas flow.
  - 12.3.5.3. Prepare a fresh standard and repeat calibration.
- 12.3.6. If the problem persists, inform the supervisor.
- 12.4. If the ICV is non-compliant, consider the following suggestions to correct the problem:
  - 12.4.1. Re-analyze ICV (to rule out poor injection).
  - 12.4.2. If ICV is still out of acceptance criteria, prepare a fresh standard and re-analyze to rule out any preparation error
  - 12.4.3. If ICV is still out of acceptance criteria, prepare a fresh ICAL standard and repeat calibration.
  - 12.4.4. If the problem persists, inform the supervisor.
- 12.5. If the instrument blank is non-compliant, consider the following suggestions to correct problem:
  - 12.5.1. Rule out instrument contamination by performing the instrument daily maintenance, such as changing septum, cleaning liner, cleaning or using new auto sampler syringe.
  - 12.5.2. Rule out reagent contamination by testing solvent used for analysis and working internal standard.
  - 12.5.3. Rule out preparation contamination by preparing a new instrument blank.
  - 12.5.4. If the problem persists, inform the supervisor.
- 12.6. If Continuing Calibration is non-compliant, consider the following suggestions to correct the problem:
  - 12.6.1. Change the liner.
  - 12.6.2. Clean injection port.
  - 12.6.3. Prepare new standard.
  - 12.6.4. Cut or replace column.
  - 12.6.5. Clean the detector.
  - 12.6.6. Rule out leaks by checking all connections.
  - 12.6.7. If continuing calibration is still non-compliant, prepare a new standard and repeat the ICAL.
- 12.7. If Method Blank is non-compliant, consider the following suggestions to correct the problem:
  - 12.7.1. Rule out instrument contamination by checking instrument blank.
  - 12.7.2. Rule out reagent contamination by testing each reagent used for extraction as described in EMAX-QC01.
  - 12.7.3. Rule out glassware contamination used for extraction as described in EMAX-QC07.

## STANDARD OPERATING PROCEDURE

**ORGANOCHLORINE PESTICIDES BY GAS CHROMATOGRAPHY**SOP No.: EMAX-8081 Revision No. 8 Effective Date: 16-Jun-14

- 
- 
- 12.7.4. Re-extract MB and the associated samples with reagents free of contamination or with newly opened reagents.
  - 12.7.5. If the problem persists, inform the supervisor.
  - 12.8. If LCS is non-compliant, perform the following suggestions to correct the problem:
    - 12.8.1. If result is bias-high or bias-low, check the LCS Standard by analyzing at the spike level.
    - 12.8.2. If LCS check is within 80-120% of expected value, check calibration of the micropipette or syringe used for spiking. Re-extract and re-analyze the LCS and the associated samples.
    - 12.8.3. If LCS check is not within 80-120% of expected value, prepare a fresh LCS Standard, re-extract and re-analyze LCS and the associated samples.
  - 12.9. Execute a Non-Conformance Report (NCR) when the following circumstances occur:
    - 12.9.1. If corrective action needs the function of other department; e.g., if the sample needs to be re-extracted, refer to EMAX-QA08 for details of completing an NCR.
    - 12.9.2. If corrective action needs the assistance of the project manager; e.g. If the sample is non-compliant to the technical holding time requirement, insufficient amount of sample, or other non-conforming issues.
  - 12.10. For other problems encountered, inform the supervisor immediately for further instructions.

**13.0 POLLUTION PREVENTION**

- 13.1. All unused samples shall be endorsed to the Waste Disposal Unit (WDU) for proper disposal. No samples shall be dumped on the laboratory sink.
- 13.2. All unused expired analytical standards shall be separated and properly identified prior to endorsing them to WDU for proper disposal.

**14.0 WASTE MANAGEMENT**

- 14.1. All unused samples, expired analytical standards and other waste generated during the analytical process, endorsed to WDU shall be disposed in accordance to EMAX-SM03.

**15.0 SUPPLEMENTARY NOTES****15.1. Definition of Terms**

- 15.1.1. Analyte – The specific chemicals or components for which a sample is analyzed; may be a group of chemicals that belong to the same chemical family, and which are analyzed together.
- 15.1.2. Batch – is a group of samples that are prepared and/or analyzed at the same time using the same lot of reagents.
  - 15.1.2.1. **Preparation Batch** – is composed of one to 20 samples of the same matrix, a method blank, a lab control sample and matrix spike/matrix spike duplicate.
  - 15.1.2.2. **Analytical Batch** – is composed of prepared samples (extracts, digestates, or concentrates), which are analyzed together as a group using an instrument in conformance to the analytical requirement. An analytical batch can include



## STANDARD OPERATING PROCEDURE

**ORGANOCHLORINE PESTICIDES BY GAS CHROMATOGRAPHY**SOP No.: EMAX-8081 Revision No. 8 Effective Date: 16-Jun-14

---

samples originating from various matrices, preparation batches, and can exceed 20 samples.

- 15.1.3. Detection Limit (DL) – is defined as the smallest analyte concentration that can be demonstrated to be different from zero or a blank concentration at the 99% level of confidence. At the DL, the false positive rate (Type I error) is 1%.
- 15.1.4. Limit of Detection (LOD) – is defined as the smallest amount or concentration of substance that must be present in a sample in order to be detected at a high level of confidence (99%). At the LOD, the false negative result rate (Type II error) is 1%.
- 15.1.5. Limit of Quantitation (LOQ) – is at the lowest concentration that produces a quantitative result within specified limits of precision and bias. For DoD projects, the LOQ shall be set at or above the concentration of the lowest initial calibration standard.
- 15.1.6. Safety Data Sheet (SDS) – is written information concerning a chemical physical properties, toxicity, health hazards, fire hazard and reactivity data including storage, spill and handling precautions.
- 15.1.7. Calibration – is a determinant measured from a standard to obtain the correct value of an instrument output.
- 15.1.8. Calibration Blank – is a target-analyte-free solvent subjected to the entire analytical process to establish zero baseline or background value.
- 15.1.9. Carry-over – are contaminants retained in the instrument/apparatus from a highly contaminated sample that is passed into the succeeding sample(s).
- 15.1.10. Instrument Method – is a file generated to contain the instrument calibration and instrument parameter settings for a particular analysis.
- 15.1.11. Method Blank – is a target-analyte-free sample subjected to the entire sample preparation and/or analytical process to monitor contamination.
- 15.1.12. Lab Control Sample (LCS) – is a target-analyte-free sample spiked with a verified known amount of target analyte(s) or a reference material with a certified known value subjected to the entire sample preparation and/or analytical process. LCS is analyzed to monitor the accuracy of the analytical system.
- 15.1.13. Lab Control Sample Duplicate (LCSD) – is a replicate of LCS analyzed to monitor precision in the absence of MS/MSD sample.
- 15.1.14. Sample – is a specimen received in the laboratory bearing a sample label traceable to the accompanying COC. Samples collected in different containers having the same field sample ID are considered the same and therefore labeled with the same lab sample ID unless otherwise specified by the project.
- 15.1.15. Sample Duplicate – is a replicate of a sub-sample taken one sample, prepared and analyzed within the same preparation batch.
- 15.1.16. Sub-sample – is an aliquot taken from a sample for analysis. Each sub-sample is uniquely identified by the sample preparation ID.
- 15.1.17. Matrix – A component or form of a sample.

## STANDARD OPERATING PROCEDURE

**ORGANOCHLORINE PESTICIDES BY GAS CHROMATOGRAPHY**

SOP No.: EMAX-8081 Revision No. 8 Effective Date: 16-Jun-14

15.1.18. Matrix Spike (MS) – is a sample spiked with a verified known amount of target analyte(s) subjected to the entire sample preparation and/or analytical process. MS is analyzed to monitor matrix effect on a method's recovery efficiency.

15.1.19. Matrix Spike Duplicate (MSD) – is a replicate of MS analyzed to monitor precision or recovery.

15.1.20. Surrogate – are compounds added to every blank, sample, matrix spike, matrix spike duplicate and standard; used to evaluate analytical efficiency by measuring recovery. Compounds not expected to be detected in environmental media.

15.1.21. Reagent Water – is purified water free from any target analyte or any other substance that may interfere with the analytical process.

15.1.22. Reagent Soil – organic-free Ottawa sand or equivalent.

#### 15.2. Application of QC Procedures

15.2.1. The procedures and QC criteria summarized in this SOP applies to all projects when performing organochlorine pesticides analysis by GC. In instances where there is a project or program QAPP, the requirements given in the project takes precedence over this SOP.

#### 15.3. Department of Defense (DoD) Projects and Department of Energy (DoE) Projects

15.3.1. Samples from DoD and DoE sponsored projects shall follow the Quality Assurance Project Plan (QAPP), Statement of Work (SOW) and/or client's quality control directive. In the absence of QAPP, the DoD Quality Systems Manual (QSM), latest update, shall be applied.

### 16.0 REFERENCES

- 16.1. "Test Methods for Evaluating Solid Waste, Physical / Chemical Methods", EPA Publication SW-846 Methods 8000B and 8081B, as updated
- 16.2. EMAX Quality Systems Manual, as updated

### 17.0 APPENDICES

#### 17.1. Figures

- |         |          |  |
|---------|----------|--|
| 17.1.1. | Figure 1 | Peak Evaluation Technique                      |
| 17.1.2. | Figure 2 | Typical Chromatogram                           |
| 17.1.3. | Figure 3 | Typical Initial Calibration Summary            |
| 17.1.4. | Figure 4 | Typical Retention Time Window Summary          |
| 17.1.5. | Figure 5 | Typical PEM PEST Breakdown Calculation Summary |
| 17.1.6. | Figure 6 | Typical Sample Result Summary                  |
| 17.1.7. | Figure 7 | Typical LCS Report Summary                     |
| 17.1.8. | Figure 8 | Typical MS/MSD Report Summary                  |
| 17.1.9. | Figure 9 | Typical Case Narrative                         |

#### 17.2. Tables

- |         |         |   |
|---------|---------|---|
| 17.2.1. | Table 1 | ICAL Concentration of Individual Analytes   |
| 17.2.2. | Table 2 | ICAL Standard Preparation                   |
| 17.2.3. | Table 3 | Intermediate Primary Standard Preparation   |
| 17.2.4. | Table 4 | Intermediate Secondary Standard Preparation |

## STANDARD OPERATING PROCEDURE

**ORGANOCHLORINE PESTICIDES BY GAS CHROMATOGRAPHY**SOP No.: EMAX-8081 Revision No. 8 Effective Date: 16-Jun-14

---

|          |                   |  |
|----------|-------------------|--|
| 17.2.5.  | Table 5           | Check Standard Preparation   |
| 17.2.6.  | Table 6           | Surrogate Standard Preparation                                     |
| 17.2.7.  | Table 7           | Spike Standard Preparation   |
| 17.2.8.  | Table 8           | Performance Evaluation Mixture Preparation                         |
| 17.2.9.  | Table 9           | CLP Retention Time Window for Pesticides                           |
| 17.2.10. | Table 10          | Established Limit of Detection (LOD) & Limit of Quantitation (LOQ) |
| 17.3.    | <b>Appendices</b> |  |
| 17.3.1.  | Appendix 1        | Summary of In-House Quality Control Procedures                     |
| 17.3.2.  | Appendix 2        | Demonstration of Capability  |
| 17.4.    | <b>Forms</b>      |  |
| 17.4.1.  | 8081FS            | Sample Preparation Log   |
| 17.4.2.  | 8081FA            | Analytical Run Log   |
| 17.4.3.  | 8081FM            | Instrument Maintenance Log   |

**Figure 1: PEAK EVALUATION TECHNIQUE**

---

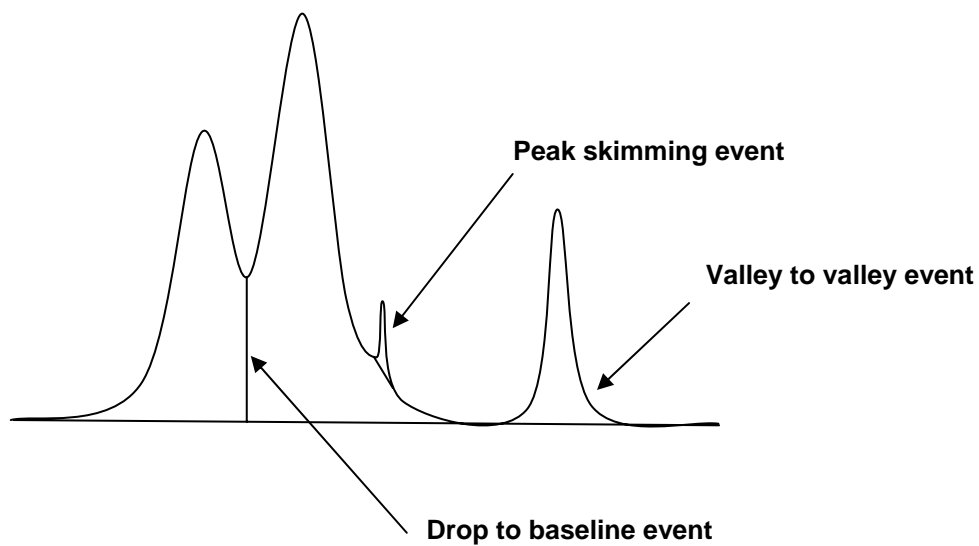
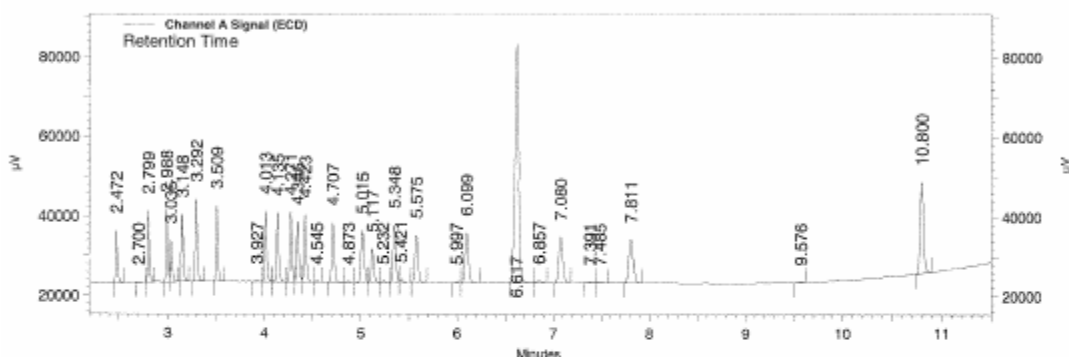

**Figure 2: TYPICAL CHROMATOGRAM**

**Organochlorine Pesticides by GC/ECD**  
**EMAX Laboratories, Inc.**

Page 1 of 2

Sample ID: ICPE8A2601 (20/200ppb PEST ICV)  
Instrument ID: E8  
Method Name: C:\EZChrom Elite\Methods\CPE8A26.met  
Data: C:\EZChrom Elite\Data\MA26\MA26034.dat  
User: Enrico  
Acquired: 01/27/14 06:35:24  
Printed: 01/27/14 11:45:07



**Channel A Signal (ECD) Results**

| Name               | Expected RT (mins) | Retention Time (mins) | Area    | Average RF | ESTD concentration (ppb) | Integration Codes |
|--------------------|--------------------|-----------------------|---------|------------|--------------------------|-------------------|
| TCX                | 2.476              | 2.472                 | 955775  | 47593.1    | 20.082                   | BB                |
| alpha-BHC          | 2.804              | 2.799                 | 1157551 | 58657.7    | 19.734                   | BB                |
| gamma-BHC          | 2.993              | 2.988                 | 1194590 | 60273.4    | 19.820                   | BV                |
| beta-BHC           | 3.040              | 3.035                 | 755069  | 37664.5    | 20.047                   | VI                |
| delta-BHC          | 3.153              | 3.148                 | 1136840 | 57926.2    | 19.626                   | BB                |
| Heptachlor         | 3.297              | 3.292                 | 1538033 | 76393.2    | 20.133                   | BB                |
| Aldrin             | 3.515              | 3.509                 | 1420481 | 70593.4    | 20.122                   | BB                |
| Heptachlor Epoxide | 4.020              | 4.013                 | 1522180 | 75468.6    | 20.170                   | VV                |
| gamma-Chlordane    | 4.141              | 4.135                 | 1539037 | 76628.8    | 20.084                   | VV                |
| alpha-Chlordane    | 4.277              | 4.271                 | 1556812 | 76507.4    | 20.349                   | VV                |
| DDE                | 4.352              | 4.345                 | 1385456 | 71405.8    | 19.403                   | VV                |
| Endosulfan I       | 4.429              | 4.423                 | 1586424 | 81710.0    | 19.415                   | VV                |
| Dieldrin           | 4.713              | 4.707                 | 1462708 | 72989.9    | 20.040                   | BV                |
| Endrin             | 5.021              | 5.015                 | 1372902 | 69755.1    | 19.682                   | BV                |
| DDD                | 5.124              | 5.117                 | 888487  | 47187.6    | 18.829                   | VV                |
| Endosulfan II      | 5.356              | 5.348                 | 1607919 | 77469.6    | 20.755                   | BV                |
| DDT                | 5.581              | 5.575                 | 1409455 | 61818.5    | 22.800                   | BB                |
| Endrin aldehyde    | 6.107              | 6.099                 | 1682493 | 81300.8    | 20.695                   | VB                |
| Methoxychlor       | 6.625              | 6.617                 | 8917026 | 42300.6    | 210.801                  | BV                |
| Endosulfan Sulfate | 7.087              | 7.080                 | 1781217 | 86351.4    | 20.628                   | BB                |
| Endrin Ketone      | 7.820              | 7.811                 | 1892134 | 97359.1    | 19.435                   | BB                |
| DCB                | 10.807             | 10.800                | 2835411 | 137403.8   | 20.636                   | BB                |

**Figure 2: TYPICAL CHROMATOGRAM**

**Organochlorine Pesticides by GC/ECD  
EMAX Laboratories, Inc.**

Page 2 of 2

Sample ID: ICPE8A2601 (20/200ppb PEST ICV)  
Instrument ID: E8  
Method Name: C:\EZChrom Elite\Methods\CPE8A26.met  
Data: C:\EZChrom Elite\Data\MA26\MA26034.dat  
User: Enrico  
Acquired: 01/27/14 06:35:24  
Printed: 01/27/14 11:45:07

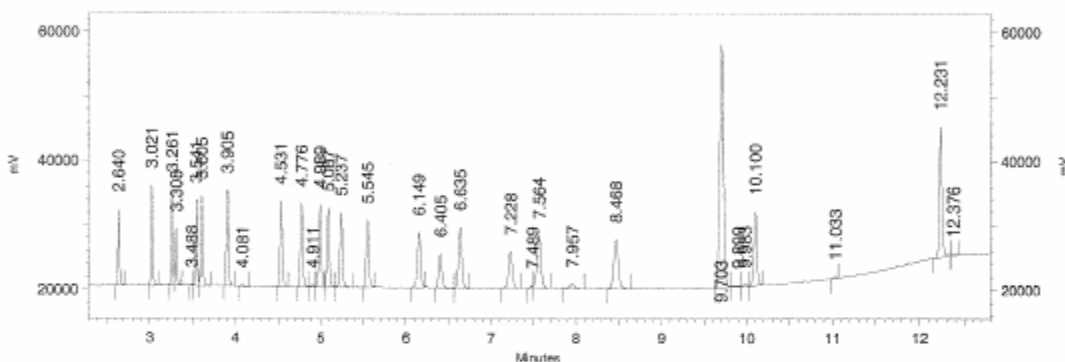

**Channel B Signal  
(ECD) Results**

| Name               | Expected RT (mins) | Retention Time (mins) | Area    | Average RF | ESTD concentration (ppb) | Integration Codes |
|--------------------|--------------------|-----------------------|---------|------------|--------------------------|-------------------|
| TCX                | 2.644              | 2.640                 | 883518  | 43071.9    | 20.513                   | BB                |
| alpha-BHC          | 3.027              | 3.021                 | 1073354 | 54398.4    | 19.731                   | BB                |
| gamma-BHC          | 3.267              | 3.261                 | 1035320 | 52652.3    | 19.663                   | BV                |
| beta-BHC           | 3.313              | 3.308                 | 674615  | 33191.9    | 20.325                   | VB                |
| delta-BHC          | 3.547              | 3.541                 | 977515  | 51049.0    | 19.149                   | VV                |
| Heptachlor         | 3.612              | 3.605                 | 1160948 | 59362.2    | 19.557                   | VB                |
| Aldrin             | 3.911              | 3.905                 | 1240610 | 62034.4    | 19.999                   | BB                |
| Heptachlor Epoxide | 4.537              | 4.531                 | 1305228 | 65794.6    | 19.838                   | BB                |
| gamma-Chlordane    | 4.783              | 4.776                 | 1339776 | 67877.6    | 19.738                   | BV                |
| alpha-Chlordane    | 4.995              | 4.989                 | 1366492 | 68399.9    | 19.978                   | VV                |
| Endosulfan I       | 5.092              | 5.087                 | 1332936 | 67777.1    | 19.666                   | VV                |
| DDE                | 5.245              | 5.237                 | 1314457 | 67645.1    | 19.432                   | VB                |
| Dieldrin           | 5.552              | 5.545                 | 1244362 | 63414.0    | 19.623                   | BB                |
| Endrin             | 6.156              | 6.149                 | 1182887 | 59723.1    | 19.806                   | BB                |
| DDD                | 6.412              | 6.405                 | 734238  | 38299.0    | 19.171                   | BB                |
| Endosulfan II      | 6.641              | 6.635                 | 1371009 | 66625.0    | 20.578                   | BB                |
| DDT                | 7.235              | 7.228                 | 959460  | 44911.8    | 21.363                   | BB                |
| Endrin Aldehyde    | 7.571              | 7.564                 | 1433036 | 69406.3    | 20.647                   | VB                |
| Endosulfan Sulfate | 8.476              | 8.468                 | 1515182 | 72700.4    | 20.841                   | BB                |
| Methoxychlor       | 9.708              | 9.703                 | 5835344 | 26720.6    | 218.384                  | BV                |
| Endrin Ketone      | 10.107             | 10.100                | 1577755 | 79509.5    | 19.844                   | BB                |
| DCB                | 12.236             | 12.231                | 2256977 | 108283.0   | 20.843                   | BV                |

**Figure 2: TYPICAL CHROMATOGRAM**

EPA 8081 by GC/ECD  
 EMAX Analytical Laboratories, Inc.

Page 1 of 1

Sample ID: ITOE8A2601 (500/25ppb TOXA ICV)  
 Instrument ID: E8  
 Method Name: C:\EZChrom Elite\Methods\TOE8A26.met  
 Data: C:\EZChrom Elite\Data\MA26\MA26044.dat  
 User: Enrico  
 Acquired: 01/27/14 09:57:27  
 Printed: 01/27/14 14:58:32

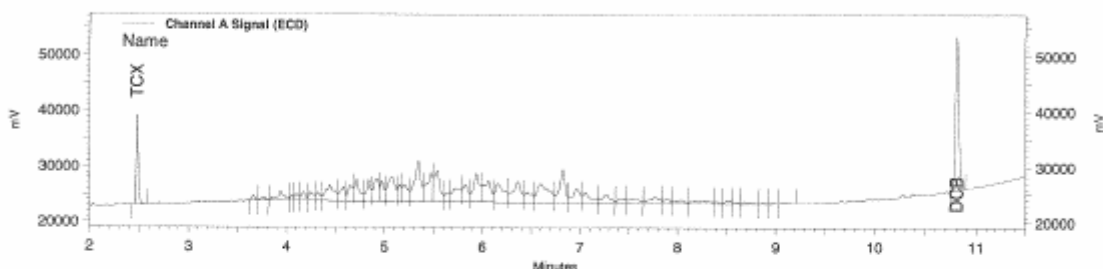

Channel A Signal  
 (ECD) Results

| Name      | Expected RT (mins) | Retention Time (mins) | Area     | Average RF | ESTD concentration | Integration Codes |
|-----------|--------------------|-----------------------|----------|------------|--------------------|-------------------|
| TCX       | 2.480              | 2.473                 | 1169230  | 47804.9    | 24.46              | BB                |
| DCB       | 10.813             | 10.804                | 3396622  | 139579.7   | 24.33              | IB                |
| Toxaphene |                    |                       | 26342693 | 57718.4    | 456.40             |                   |

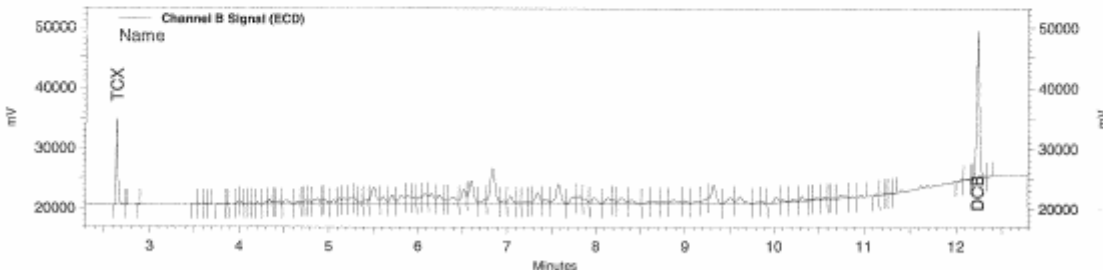

Channel B Signal  
 (ECD) Results

| Name      | Expected RT (mins) | Retention Time (mins) | Area     | Average RF | ESTD concentration | Integration Codes |
|-----------|--------------------|-----------------------|----------|------------|--------------------|-------------------|
| TCX       | 2.648              | 2.641                 | 1055995  | 42950.1    | 24.59              | BV                |
| DCB       | 12.243             | 12.235                | 2709359  | 112370.7   | 24.11              | VV                |
| Toxaphene |                    |                       | 16053757 | 37656.5    | 426.32             |                   |

**Figure 2: TYPICAL CHROMATOGRAM**

EPA 8081 by GC/ECD  
 EMAX Analytical Laboratories, Inc.

Page 1 of 1

Sample ID: ICRE8A2601 (500/25ppb CHLO ICAL)  
 Instrument ID: E8  
 Method Name: C:\EZChrom Elite\Methods\CRE8A26.met  
 Data: C:\EZChrom Elite\Data\MA26\MA26017.dat  
 User: Enrico  
 Acquired: 01/27/14 00:47:35  
 Printed: 01/27/14 15:39:10

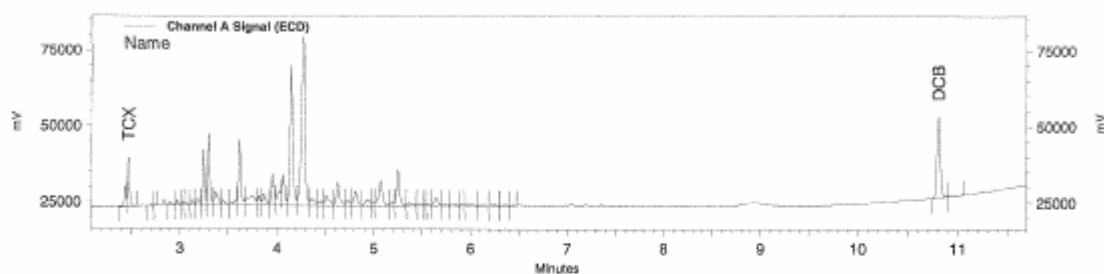

Channel A Signal  
 (ECD) Results

| Name | Expected RT (mins) | Retention Time (mins) | Area    | Average RF | ESTD concentration | Integration Codes |
|------|--------------------|-----------------------|---------|------------|--------------------|-------------------|
| TCX  | 2.475              | 2.475                 | 1186519 | 56032.1    | 25.24              | VB                |
| DCB  | 10.805             | 10.808                | 3266020 | 136656.8   | 23.90              | BV                |

Chlordane 31698308 70804.8 447.69

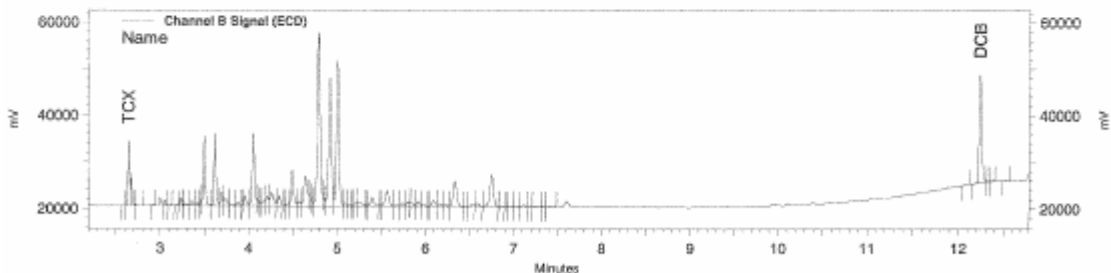

Channel B Signal  
 (ECD) Results

| Name | Expected RT (mins) | Retention Time (mins) | Area    | Average RF | ESTD concentration | Integration Codes |
|------|--------------------|-----------------------|---------|------------|--------------------|-------------------|
| TCX  | 2.643              | 2.643                 | 955172  | 47673.5    | 24.89              | SV                |
| DCB  | 12.233             | 12.236                | 2585430 | 111115.9   | 23.27              | SS                |

Chlordane 25015410 55675.2 449.31



**Figure 3: TYPICAL INITIAL CALIBRATION SUMMARY**

INITIAL CALIBRATION  
METHOD 8081

Lab Name : EMAX Inc  
Instrument ID : E8 (PE CLARUS680 GC)  
GC Column : STX-CLPESTICIDES  
Column size ID : 30MX0.32MMIDXD.32UM  
LFID & Datetime: MA26018A 01/27/14 01:07 MA26026A 01/27/14 03:51  
LFID & Datetime: MA26019A 01/27/14 01:28 MA26027A 01/27/14 04:11  
LFID & Datetime: MA26020A 01/27/14 01:48 MA26028A 01/27/14 04:32  
LFID & Datetime: MA26021A 01/27/14 02:08 MA26029A 01/27/14 04:52  
LFID & Datetime: MA26022A 01/27/14 02:29 MA26030A 01/27/14 05:13  
LFID & Datetime: MA26023A 01/27/14 02:49 MA26031A 01/27/14 05:33  
LFID & Datetime: MA26024A 01/27/14 03:10 MA26032A 01/27/14 05:54  
LFID & Datetime: MA26025A 01/27/14 03:30 MA26033A 01/27/14 06:14  
CONC UNIT: ppb

| COMPOUND           | CONC<br>X | CALIBRATION FACTORS |        |        |        |        | (AREA)/UNIT |        |        |          | MEAN | %RSD |
|--------------------|-----------|---------------------|--------|--------|--------|--------|-------------|--------|--------|----------|------|------|
|                    |           | 1.00X               | 2.00X  | 4.00X  | 8.00X  | 16.00X | 32.00X      | 48.00X | 64.00X |          |      |      |
| alpha-BHC          | 1.25      | 50461               | 49985  | 49796  | 51003  | 58714  | 65922       | 69878  | 73502  | 58657.7  | 16.8 |      |
| Hexachlorobenzene  | 1.25      | 151680              | 148744 | 145587 | 138470 | 133198 | 123809      | 116985 | 114133 | 134075.9 | 10.8 |      |
| gamma-BHC          | 1.25      | 55418               | 53472  | 53056  | 53869  | 60438  | 65819       | 68546  | 71570  | 60273.4  | 12.4 |      |
| beta-BHC           | 1.25      | 39043               | 38406  | 38222  | 36583  | 37752  | 37503       | 36734  | 37073  | 37664.5  | 2.3  |      |
| delta-BHC          | 1.25      | 51082               | 49967  | 49089  | 50261  | 57320  | 64522       | 68615  | 72553  | 57926.2  | 16.2 |      |
| Heptachlor         | 1.25      | 75430               | 75028  | 75331  | 73383  | 76309  | 78158       | 78010  | 79497  | 76393.2  | 2.6  |      |
| Aldrin             | 1.25      | 67579               | 66786  | 65338  | 65515  | 70864  | 74279       | 76074  | 78312  | 70593.4  | 7.2  |      |
| Heptachlor Epoxide | 1.25      | 78332               | 76078  | 74193  | 72576  | 75070  | 75350       | 75340  | 76810  | 75468.6  | 2.3  |      |
| gamma-Chlordane    | 1.25      | 81370               | 76728  | 75232  | 72774  | 75604  | 76192       | 76714  | 78415  | 76628.8  | 3.3  |      |
| alpha-Chlordane    | 1.25      | 76556               | 75072  | 74055  | 72745  | 76650  | 78084       | 78783  | 80113  | 76507.4  | 3.2  |      |
| DDE                | 2.50      | 71592               | 67348  | 66695  | 65767  | 71126  | 74599       | 76133  | 77986  | 71405.8  | 6.4  |      |
| Endosulfan I       | 1.25      | 84110               | 81668  | 80093  | 78406  | 81687  | 82227       | 82191  | 83299  | 81710.0  | 2.2  |      |
| Dieldrin           | 2.50      | 69740               | 68141  | 67673  | 67755  | 74240  | 77494       | 78779  | 80097  | 72989.9  | 7.2  |      |
| Endrin             | 2.50      | 71365               | 68714  | 66974  | 65349  | 69459  | 71328       | 71420  | 73432  | 69755.1  | 3.8  |      |
| DDD                | 2.50      | 41701               | 41991  | 41886  | 42268  | 47206  | 51556       | 54297  | 56596  | 47187.6  | 13.1 |      |
| Endosulfan II      | 2.50      | 78419               | 77252  | 75515  | 74694  | 78285  | 78634       | 78291  | 78667  | 77469.6  | 2.0  |      |
| DDT                | 2.50      | 60030               | 58843  | 58134  | 57951  | 61977  | 64277       | 65890  | 67446  | 61818.5  | 6.0  |      |
| Endrin Aldehyde    | 2.50      | 90040               | 86147  | 83229  | 80437  | 80903  | 78039       | 76352  | 75260  | 81300.8  | 6.2  |      |
| Methoxychlor       | 12.50     | 46278               | 44926  | 43915  | 42720  | 43071  | 40728       | 38661  | 38106  | 42300.6  | 6.9  |      |
| Endosulfan Sulfate | 2.50      | 91863               | 88645  | 86689  | 85372  | 86467  | 84607       | 83791  | 83376  | 86351.4  | 3.3  |      |
| Endrin Ketone      | 2.50      | 97937               | 95853  | 94346  | 93656  | 98673  | 99419       | 99172  | 99816  | 97359.1  | 2.5  |      |
| Oxychlordane       | 1.25      | 80110               | 76552  | 74949  | 70885  | 69034  | 65794       | 63498  | 63506  | 70540.9  | 8.8  |      |
| 2,4'-DDE           | 1.25      | 61390               | 61447  | 61948  | 59722  | 59374  | 58300       | 57066  | 58216  | 59682.8  | 3.0  |      |
| trans-Nonachlor    | 1.25      | 99849               | 98909  | 97932  | 94988  | 94271  | 92067       | 89873  | 91036  | 94865.7  | 4.0  |      |
| 2,4'-DDD           | 1.25      | 45894               | 46222  | 47460  | 46120  | 46089  | 45603       | 45404  | 46864  | 46207.1  | 1.4  |      |
| 2,4'-DDT           | 1.25      | 63857               | 63837  | 63385  | 61709  | 61841  | 60822       | 59872  | 61548  | 62108.8  | 2.3  |      |
| cis-Nonachlor      | 1.25      | 103410              | 104959 | 101085 | 96481  | 95137  | 93261       | 91561  | 93833  | 97465.8  | 5.2  |      |
| Mirex              | 1.25      | 124772              | 123651 | 121188 | 114831 | 109357 | 101324      | 95348  | 94069  | 110567.4 | 11.3 |      |
| SURROGATE          | X         | 1.00X               | 2.00X  | 4.00X  | 8.00X  | 16.00X | 32.00X      | 48.00X | 64.00X | MEAN     | %RSD |      |
| TCX                | 1.25      | 50050               | 49210  | 47871  | 46818  | 47525  | 46713       | 46347  | 46212  | 47593.1  | 2.9  |      |
| DCB                | 1.25      | 150585              | 148308 | 144355 | 140284 | 139179 | 130342      | 123677 | 122500 | 137403.8 | 7.8  |      |

**Figure 3: TYPICAL INITIAL CALIBRATION SUMMARY**

INITIAL CALIBRATION  
METHOD 8081

Lab Name : EMAX Inc  
Instrument ID : E8 (PE CLARUS680 GC)  
GC Column : STX-CLPESTICIDES2  
Column size ID : 30MX0.32MMIDX0.25UM  
LFID & Datetime: MA26018B 01/27/14 01:07 MA26026B 01/27/14 03:51  
LFID & Datetime: MA26019B 01/27/14 01:28 MA26027B 01/27/14 04:11  
LFID & Datetime: MA26020B 01/27/14 01:48 MA26028B 01/27/14 04:32  
LFID & Datetime: MA26021B 01/27/14 02:08 MA26029B 01/27/14 04:52  
LFID & Datetime: MA26022B 01/27/14 02:29 MA26030B 01/27/14 05:13  
LFID & Datetime: MA26023B 01/27/14 02:49 MA26031B 01/27/14 05:33  
LFID & Datetime: MA26024B 01/27/14 03:10 MA26032B 01/27/14 05:54  
LFID & Datetime: MA26025B 01/27/14 03:30 MA26033B 01/27/14 06:14  
CONC UNIT: ppb

| COMPOUND           | CONC<br>X | CALIBRATION FACTORS |        |        |        |        |        |        |        | (AREA)/UNIT |      | MEAN | %RSD |
|--------------------|-----------|---------------------|--------|--------|--------|--------|--------|--------|--------|-------------|------|------|------|
|                    |           | 1.00X               | 2.00X  | 4.00X  | 8.00X  | 16.00X | 32.00X | 48.00X | 64.00X |             |      |      |      |
| alpha-BHC          | 1.25      | 50646               | 48650  | 45661  | 45897  | 51758  | 60345  | 64329  | 67899  | 54398.4     | 15.8 |      |      |
| Hexachlorobenzene  | 1.25      | 142667              | 129534 | 130501 | 124881 | 119255 | 112893 | 107022 | 104412 | 121395.5    | 10.7 |      |      |
| gamma-BHC          | 1.25      | 45669               | 45113  | 44964  | 46196  | 52559  | 59047  | 62269  | 65403  | 52652.3     | 16.1 |      |      |
| beta-BHC           | 1.25      | 31707               | 31626  | 31893  | 32056  | 34007  | 34380  | 34498  | 35369  | 33191.9     | 4.6  |      |      |
| delta-BHC          | 1.25      | 46881               | 43645  | 42802  | 42935  | 48916  | 56753  | 61137  | 65324  | 51049.0     | 17.3 |      |      |
| Heptachlor         | 1.25      | 64469               | 60382  | 56873  | 54863  | 57269  | 59256  | 60104  | 61682  | 59362.2     | 5.1  |      |      |
| Aldrin             | 1.25      | 57630               | 56940  | 55957  | 56535  | 61716  | 66453  | 68960  | 72085  | 62034.4     | 10.2 |      |      |
| Heptachlor Epoxide | 1.25      | 67663               | 65619  | 63343  | 62127  | 65151  | 66233  | 67036  | 69183  | 65794.5     | 3.5  |      |      |
| gamma-Chlordane    | 1.25      | 76197               | 66656  | 64093  | 63110  | 65815  | 67298  | 68580  | 71272  | 67877.6     | 6.2  |      |      |
| alpha-Chlordane    | 1.25      | 70136               | 67140  | 65002  | 63977  | 67396  | 69438  | 70904  | 73206  | 68399.9     | 4.5  |      |      |
| DDE                | 2.50      | 68214               | 64858  | 62697  | 62248  | 66686  | 70036  | 72249  | 74172  | 67645.1     | 6.4  |      |      |
| Endosulfan I       | 1.25      | 66117               | 65987  | 64767  | 64418  | 67911  | 69585  | 70883  | 72549  | 67777.1     | 4.4  |      |      |
| Dieldrin           | 2.50      | 58155               | 57964  | 57460  | 58302  | 63671  | 68435  | 70661  | 72665  | 63414.0     | 10.0 |      |      |
| Endrin             | 2.50      | 60556               | 59309  | 57503  | 56433  | 59308  | 60591  | 60787  | 63298  | 59723.1     | 3.5  |      |      |
| DDD                | 2.50      | 34514               | 33973  | 34920  | 34687  | 37768  | 40811  | 43220  | 46498  | 38299.0     | 12.3 |      |      |
| Endosulfan II      | 2.50      | 65007               | 64584  | 63685  | 63806  | 67073  | 68650  | 69168  | 71027  | 66625.0     | 4.2  |      |      |
| DDT                | 2.50      | 42030               | 43174  | 42810  | 42513  | 44950  | 46480  | 47650  | 49689  | 44911.9     | 6.2  |      |      |
| Endrin Aldehyde    | 2.50      | 72006               | 71214  | 69592  | 68371  | 70244  | 68647  | 67376  | 67801  | 69406.3     | 2.4  |      |      |
| Methoxychlor       | 12.50     | 27839               | 26742  | 26456  | 26189  | 27140  | 26720  | 26095  | 26583  | 26720.6     | 2.1  |      |      |
| Endosulfan Sulfate | 2.50      | 73417               | 74342  | 72545  | 71104  | 72952  | 72408  | 71798  | 73038  | 72700.4     | 1.4  |      |      |
| Endrin Ketone      | 2.50      | 79128               | 76695  | 75503  | 76098  | 80835  | 82285  | 82088  | 83444  | 79509.5     | 3.9  |      |      |
| Oxychlorane        | 1.25      | 64121               | 62089  | 64713  | 61264  | 56762  | 55132  | 54054  | 54658  | 59099.1     | 7.5  |      |      |
| 2,4'-DDE           | 1.25      | 70189               | 62449  | 62560  | 58101  | 56371  | 54969  | 53988  | 55432  | 59257.5     | 9.3  |      |      |
| trans-Nonachlor    | 1.25      | 99838               | 95641  | 90381  | 84884  | 83673  | 82103  | 81026  | 82847  | 87549.1     | 8.0  |      |      |
| 2,4'-DDD           | 1.25      | 37678               | 36580  | 38190  | 39037  | 38970  | 39056  | 38826  | 40355  | 38586.6     | 2.9  |      |      |
| 2,4'-DDT           | 1.25      | 47592               | 47648  | 48035  | 46663  | 46259  | 45738  | 45245  | 46948  | 46766.0     | 2.1  |      |      |
| cis-Nonachlor      | 1.25      | 81732               | 82641  | 83614  | 82015  | 81911  | 81936  | 81389  | 84595  | 82479.3     | 1.3  |      |      |
| Mirex              | 1.25      | 103786              | 105295 | 105696 | 98553  | 93488  | 86478  | 81497  | 80940  | 94466.8     | 11.1 |      |      |
| SURROGATE          | X         | 1.00X               | 2.00X  | 4.00X  | 8.00X  | 16.00X | 32.00X | 48.00X | 64.00X | MEAN        | %RSD |      |      |
| TCX                | 1.25      | 43237               | 44796  | 44334  | 42283  | 43035  | 42766  | 42017  | 42107  | 43071.9     | 2.4  |      |      |
| DCB                | 1.25      | 119147              | 116443 | 112721 | 109164 | 108641 | 103690 | 99108  | 97351  | 108283.0    | 7.2  |      |      |

**Figure 3: TYPICAL INITIAL CALIBRATION SUMMARY**

INITIAL CALIBRATION  
 METHOD 8081/608

Lab Name : EMAX Inc  
 Instrument ID : EB (PE CLARUS680 GC)  
 GC Column : STX-CLPESTICIDES  
 Column size ID : 30MX0.32MMIDX0.32UM  
 LFD & Datetime: MA26036A 01/27/14 07:16  
 LFD & Datetime: MA26037A 01/27/14 07:36  
 LFD & Datetime: MA26038A 01/27/14 07:56  
 LFD & Datetime: MA26039A 01/27/14 08:16  
 LFD & Datetime: MA26040A 01/27/14 08:36  
 LFD & Datetime: MA26041A 01/27/14 08:57  
 LFD & Datetime: MA26042A 01/27/14 09:17  
 LFD & Datetime: MA26043A 01/27/14 09:37  
 CONC UNIT: ppb

| COMPOUND  | CONC<br>x | CALIBRATION FACTORS (AREA or HEIGHT)/UNIT |       |       |        |        |        |        |        | MEAN    | %RSD |
|-----------|-----------|---|-------|-------|--------|--------|--------|--------|--------|---------|------|
|           |           | 1.00x                                     | 2.00x | 5.00x | 10.00x | 15.00x | 20.00x | 30.00x | 40.00x |         |      |
| Toxaphene | 50.00     | 58631                                     | 53413 | 56818 | 57730  | 58674  | 58520  | 58234  | 59727  | 57718.4 | 3.3  |

INITIAL CALIBRATION  
 METHOD 8081/608

Lab Name : EMAX Inc  
 Instrument ID : EB (PE CLARUS680 GC)  
 GC Column : STX-CLPESTICIDES2  
 Column size ID : 30MX0.32MMIDX0.25UM  
 LFD & Datetime: MA26036B 01/27/14 07:16  
 LFD & Datetime: MA26037B 01/27/14 07:36  
 LFD & Datetime: MA26038B 01/27/14 07:56  
 LFD & Datetime: MA26039B 01/27/14 08:16  
 LFD & Datetime: MA26040B 01/27/14 08:36  
 LFD & Datetime: MA26041B 01/27/14 08:57  
 LFD & Datetime: MA26042B 01/27/14 09:17  
 LFD & Datetime: MA26043B 01/27/14 09:37  
 CONC UNIT: ppb

| COMPOUND  | CONC<br>x | CALIBRATION FACTORS (AREA or HEIGHT)/UNIT |       |       |        |        |        |        |        | MEAN    | %RSD |
|-----------|-----------|---|-------|-------|--------|--------|--------|--------|--------|---------|------|
|           |           | 1.00x                                     | 2.00x | 5.00x | 10.00x | 15.00x | 20.00x | 30.00x | 40.00x |         |      |
| Toxaphene | 50.00     | 38754                                     | 36281 | 36249 | 36766  | 37480  | 37838  | 38209  | 39675  | 37656.5 | 3.2  |

**Figure 3: TYPICAL INITIAL CALIBRATION SUMMARY**

INITIAL CALIBRATION  
 METHOD EPA 8081

Lab Name : EMAX Inc  
 Instrument ID : E8 (PE CLARUS680 GC)  
 GC Column : STX-CLPESTICIDES  
 Column size ID : 30MX0.32MMIDX0.32UM  
 LFD & Datetime: MA26009A 01/26/14 22:07  
 LFD & Datetime: MA26010A 01/26/14 22:27  
 LFD & Datetime: MA26011A 01/26/14 22:47  
 LFD & Datetime: MA26012A 01/26/14 23:07  
 LFD & Datetime: MA26013A 01/26/14 23:27  
 LFD & Datetime: MA26014A 01/26/14 23:47  
 LFD & Datetime: MA26015A 01/27/14 00:07  
 LFD & Datetime: MA26016A 01/27/14 00:27  
 CONC UNIT: ppb

| COMPOUND  | CONC<br>X | CALIBRATION FACTORS (AREA or HEIGHT)/UNIT |       |       |        |        |        |        |        | MEAN    | %RSD |
|-----------|-----------|---|-------|-------|--------|--------|--------|--------|--------|---------|------|
|           |           | 1.00X                                     | 2.00X | 4.00X | 10.00X | 20.00X | 30.00X | 40.00X | 60.00X |         |      |
| CHLORDANE | 25.00     | 89545                                     | 68121 | 80192 | 70426  | 67071  | 64747  | 63980  | 62357  | 70804.9 | 13.2 |

Lab Name : EMAX Inc  
 Instrument ID : E8 (PE CLARUS680 GC)  
 GC Column : STX-CLPESTICIDES2  
 Column size ID : 30MX0.32MMIDX0.25UM  
 LFD & Datetime: MA26009B 01/26/14 22:07  
 LFD & Datetime: MA26010B 01/26/14 22:27  
 LFD & Datetime: MA26011B 01/26/14 22:47  
 LFD & Datetime: MA26012B 01/26/14 23:07  
 LFD & Datetime: MA26013B 01/26/14 23:27  
 LFD & Datetime: MA26014B 01/26/14 23:47  
 LFD & Datetime: MA26015B 01/27/14 00:07  
 LFD & Datetime: MA26016B 01/27/14 00:27  
 CONC UNIT: ppb

| COMPOUND  | CONC<br>X | CALIBRATION FACTORS (AREA or HEIGHT)/UNIT |       |       |        |        |        |        |        | MEAN    | %RSD |
|-----------|-----------|---|-------|-------|--------|--------|--------|--------|--------|---------|------|
|           |           | 1.00X                                     | 2.00X | 4.00X | 10.00X | 20.00X | 30.00X | 40.00X | 60.00X |         |      |
| CHLORDANE | 25.00     | 74070                                     | 56360 | 52924 | 51998  | 52846  | 52524  | 52477  | 52202  | 55675.2 | 13.6 |

**Figure 4: TYPICAL ICAL RETENTION TIME WINDOW SUMMARY**

INITIAL CALIBRATION  
 METHOD 8081

Lab Name : EMAX Inc  
 Instrument ID : E8 (PE CLARUS680 GC)  
 GC Column : STX-CLPESTICIDES  
 Column size ID : 30MX0.32MMIDX0.32UM  
 LFID & Datetime: MA26018A 01/27/14 01:07 MA26026A 01/27/14 03:51  
 LFID & Datetime: MA26019A 01/27/14 01:28 MA26027A 01/27/14 04:11  
 LFID & Datetime: MA26020A 01/27/14 01:48 MA26028A 01/27/14 04:32  
 LFID & Datetime: MA26021A 01/27/14 02:08 MA26029A 01/27/14 04:52  
 LFID & Datetime: MA26022A 01/27/14 02:29 MA26030A 01/27/14 05:13  
 LFID & Datetime: MA26023A 01/27/14 02:49 MA26031A 01/27/14 05:33  
 LFID & Datetime: MA26024A 01/27/14 03:10 MA26032A 01/27/14 05:54  
 LFID & Datetime: MA26025A 01/27/14 03:30 MA26033A 01/27/14 06:14

| COMPOUND           | RT OF STANDARDS (MIN) |        |        |        |        |        |        |        | MEAN RT | RT WINDOW |        | RTWINDOW WIDTH |
|--------------------|-----------------------|--------|--------|--------|--------|--------|--------|--------|---------|-----------|--------|----------------|
|                    | 1.0X                  | 2.0X   | 4.0X   | 8.0X   | 16.0X  | 32.0X  | 48.0X  | 64.0X  |         | FROM      | TO     |                |
| alpha-BHC          | 2.800                 | 2.801  | 2.800  | 2.805  | 2.804  | 2.804  | 2.803  | 2.801  | 2.802   | 2.782     | 2.822  | 0.020          |
| Hexachlorobenzene  | 2.704                 | 2.707  | 2.708  | 2.699  | 2.701  | 2.705  | 2.705  | 2.701  | 2.704   | 2.684     | 2.724  | 0.020          |
| gamma-BHC          | 2.988                 | 2.991  | 2.988  | 2.995  | 2.993  | 2.993  | 2.992  | 2.989  | 2.991   | 2.969     | 3.013  | 0.022          |
| beta-BHC           | 3.036                 | 3.039  | 3.036  | 3.043  | 3.040  | 3.041  | 3.039  | 3.037  | 3.039   | 3.017     | 3.061  | 0.022          |
| delta-BHC          | 3.149                 | 3.151  | 3.148  | 3.155  | 3.153  | 3.155  | 3.152  | 3.151  | 3.152   | 3.131     | 3.173  | 0.021          |
| Heptachlor         | 3.293                 | 3.295  | 3.293  | 3.299  | 3.297  | 3.297  | 3.296  | 3.293  | 3.295   | 3.271     | 3.319  | 0.024          |
| Aldrin             | 3.511                 | 3.512  | 3.511  | 3.516  | 3.515  | 3.515  | 3.513  | 3.511  | 3.513   | 3.487     | 3.539  | 0.026          |
| Heptachlor Epoxide | 4.016                 | 4.019  | 4.016  | 4.023  | 4.020  | 4.021  | 4.019  | 4.016  | 4.019   | 3.989     | 4.049  | 0.030          |
| gamma-Chlordane    | 4.137                 | 4.139  | 4.136  | 4.143  | 4.141  | 4.141  | 4.140  | 4.137  | 4.139   | 4.107     | 4.171  | 0.032          |
| alpha-Chlordane    | 4.273                 | 4.275  | 4.272  | 4.279  | 4.277  | 4.277  | 4.276  | 4.273  | 4.275   | 4.243     | 4.307  | 0.032          |
| DDE                | 4.348                 | 4.349  | 4.348  | 4.353  | 4.352  | 4.353  | 4.351  | 4.348  | 4.350   | 4.318     | 4.382  | 0.032          |
| Endosulfan I       | 4.425                 | 4.427  | 4.425  | 4.431  | 4.429  | 4.429  | 4.428  | 4.425  | 4.427   | 4.392     | 4.462  | 0.035          |
| Dieldrin           | 4.711                 | 4.712  | 4.709  | 4.716  | 4.713  | 4.715  | 4.712  | 4.709  | 4.712   | 4.680     | 4.744  | 0.032          |
| Endrin             | 5.021                 | 5.020  | 5.019  | 5.025  | 5.021  | 5.024  | 5.021  | 5.019  | 5.021   | 4.991     | 5.051  | 0.030          |
| DDD                | 5.121                 | 5.121  | 5.120  | 5.127  | 5.124  | 5.127  | 5.124  | 5.121  | 5.123   | 5.093     | 5.153  | 0.030          |
| Endosulfan II      | 5.353                 | 5.353  | 5.352  | 5.359  | 5.356  | 5.357  | 5.355  | 5.352  | 5.355   | 5.326     | 5.384  | 0.029          |
| DDT                | 5.580                 | 5.580  | 5.579  | 5.584  | 5.581  | 5.583  | 5.581  | 5.579  | 5.581   | 5.551     | 5.611  | 0.030          |
| Endrin Aldehyde    | 6.104                 | 6.104  | 6.103  | 6.108  | 6.107  | 6.107  | 6.104  | 6.101  | 6.105   | 6.073     | 6.137  | 0.032          |
| Methoxychlor       | 6.624                 | 6.623  | 6.624  | 6.629  | 6.625  | 6.628  | 6.624  | 6.620  | 6.625   | 6.587     | 6.663  | 0.038          |
| Endosulfan Sulfate | 7.085                 | 7.085  | 7.085  | 7.091  | 7.087  | 7.089  | 7.085  | 7.083  | 7.086   | 7.050     | 7.122  | 0.036          |
| Endrin Ketone      | 7.817                 | 7.819  | 7.817  | 7.821  | 7.820  | 7.820  | 7.817  | 7.815  | 7.818   | 7.782     | 7.854  | 0.036          |
| Oxychlordane       | 3.925                 | 3.927  | 3.927  | 3.919  | 3.921  | 3.925  | 3.925  | 3.921  | 3.924   | 3.905     | 3.943  | 0.019          |
| 2,4'-DDE           | 3.999                 | 4.000  | 4.000  | 3.992  | 3.995  | 4.000  | 4.000  | 3.995  | 3.998   | 3.976     | 4.020  | 0.022          |
| trans-Nonachlor    | 4.257                 | 4.259  | 4.259  | 4.251  | 4.253  | 4.259  | 4.259  | 4.253  | 4.256   | 4.233     | 4.279  | 0.023          |
| 2,4'-DDD           | 4.551                 | 4.552  | 4.552  | 4.544  | 4.547  | 4.551  | 4.552  | 4.545  | 4.549   | 4.524     | 4.574  | 0.025          |
| 2,4'-DDT           | 4.880                 | 4.880  | 4.880  | 4.872  | 4.875  | 4.879  | 4.880  | 4.875  | 4.878   | 4.855     | 4.901  | 0.023          |
| cis-Nonachlor      | 5.072                 | 5.072  | 5.072  | 5.064  | 5.067  | 5.071  | 5.072  | 5.067  | 5.070   | 5.048     | 5.092  | 0.022          |
| Mirex              | 6.788                 | 6.788  | 6.788  | 6.781  | 6.783  | 6.785  | 6.788  | 6.781  | 6.785   | 6.757     | 6.813  | 0.028          |
| SURROGATE          | 1.0X                  | 2.0X   | 4.0X   | 8.0X   | 16.0X  | 32.0X  | 48.0X  | 64.0X  | RT      | FROM      | TO     | WIDTH          |
| TCX                | 2.472                 | 2.475  | 2.472  | 2.477  | 2.476  | 2.476  | 2.475  | 2.473  | 2.474   | 2.454     | 2.494  | 0.020          |
| DCB                | 10.804                | 10.804 | 10.803 | 10.807 | 10.807 | 10.805 | 10.801 | 10.801 | 10.804  | 10.754    | 10.854 | 0.050          |

**Figure 4: TYPICAL ICAL RETENTION TIME WINDOW SUMMARY**

INITIAL CALIBRATION  
METHOD 8081

Lab Name : EMAX Inc  
Instrument ID : E8 (PE CLARUS680 GC)  
GC Column : STX-CLPESTICIDES2  
Column size ID : 30MX0.32MMIDX0.25UM  
LFID & Datetime: MA26018B 01/27/14 01:07 MA26026B 01/27/14 03:51  
LFID & Datetime: MA26019B 01/27/14 01:28 MA26027B 01/27/14 04:11  
LFID & Datetime: MA26020B 01/27/14 01:48 MA26028B 01/27/14 04:32  
LFID & Datetime: MA26021B 01/27/14 02:08 MA26029B 01/27/14 04:52  
LFID & Datetime: MA26022B 01/27/14 02:29 MA26030B 01/27/14 05:13  
LFID & Datetime: MA26023B 01/27/14 02:49 MA26031B 01/27/14 05:33  
LFID & Datetime: MA26024B 01/27/14 03:10 MA26032B 01/27/14 05:54  
LFID & Datetime: MA26025B 01/27/14 03:30 MA26033B 01/27/14 06:14

| COMPOUND           | RT OF STANDARDS (MIN) |        |        |        |        |        |        |        | MEAN RT | RT WINDOW |        | RTWINDOW WIDTH |
|--------------------|-----------------------|--------|--------|--------|--------|--------|--------|--------|---------|-----------|--------|----------------|
|                    | 1.0X                  | 2.0X   | 4.0X   | 8.0X   | 16.0X  | 32.0X  | 48.0X  | 64.0X  |         | FROM      | TO     |                |
| alpha-BHC          | 3.021                 | 3.024  | 3.023  | 3.029  | 3.027  | 3.027  | 3.025  | 3.024  | 3.025   | 3.007     | 3.043  | 0.018          |
| Hexachlorobenzene  | 2.941                 | 2.944  | 2.945  | 2.936  | 2.939  | 2.944  | 2.943  | 2.939  | 2.941   | 2.923     | 2.959  | 0.018          |
| gamma-BHC          | 3.261                 | 3.264  | 3.261  | 3.268  | 3.267  | 3.267  | 3.264  | 3.263  | 3.264   | 3.247     | 3.281  | 0.017          |
| beta-BHC           | 3.308                 | 3.311  | 3.309  | 3.316  | 3.313  | 3.313  | 3.312  | 3.309  | 3.311   | 3.294     | 3.328  | 0.017          |
| delta-BHC          | 3.541                 | 3.545  | 3.543  | 3.549  | 3.547  | 3.547  | 3.548  | 3.545  | 3.544   | 3.545     | 3.528  | 0.017          |
| Heptachlor         | 3.607                 | 3.611  | 3.608  | 3.615  | 3.612  | 3.612  | 3.609  | 3.608  | 3.610   | 3.592     | 3.628  | 0.018          |
| Aldrin             | 3.907                 | 3.909  | 3.908  | 3.913  | 3.911  | 3.912  | 3.909  | 3.908  | 3.910   | 3.891     | 3.929  | 0.019          |
| Heptachlor Epoxide | 4.533                 | 4.536  | 4.533  | 4.540  | 4.537  | 4.539  | 4.536  | 4.533  | 4.536   | 4.513     | 4.559  | 0.023          |
| gamma-Chlordane    | 4.780                 | 4.783  | 4.780  | 4.785  | 4.783  | 4.785  | 4.781  | 4.779  | 4.782   | 4.761     | 4.803  | 0.021          |
| alpha-Chlordane    | 4.992                 | 4.993  | 4.992  | 4.999  | 4.995  | 4.997  | 4.995  | 4.991  | 4.994   | 4.976     | 5.012  | 0.018          |
| DDE                | 5.241                 | 5.244  | 5.241  | 5.248  | 5.245  | 5.247  | 5.244  | 5.241  | 5.244   | 5.228     | 5.260  | 0.016          |
| Endosulfan I       | 5.089                 | 5.092  | 5.089  | 5.096  | 5.092  | 5.095  | 5.093  | 5.089  | 5.092   | 5.073     | 5.111  | 0.019          |
| Dieldrin           | 5.548                 | 5.551  | 5.549  | 5.556  | 5.552  | 5.555  | 5.551  | 5.548  | 5.551   | 5.534     | 5.568  | 0.017          |
| Endrin             | 6.155                 | 6.156  | 6.155  | 6.161  | 6.156  | 6.159  | 6.156  | 6.153  | 6.156   | 6.136     | 6.176  | 0.020          |
| DDD                | 6.409                 | 6.412  | 6.411  | 6.416  | 6.412  | 6.415  | 6.412  | 6.408  | 6.412   | 6.393     | 6.431  | 0.019          |
| Endosulfan II      | 6.640                 | 6.641  | 6.639  | 6.645  | 6.641  | 6.644  | 6.641  | 6.636  | 6.641   | 6.619     | 6.663  | 0.022          |
| DDT                | 7.232                 | 7.235  | 7.233  | 7.240  | 7.235  | 7.237  | 7.235  | 7.231  | 7.235   | 7.211     | 7.259  | 0.024          |
| Endrin Aldehyde    | 7.568                 | 7.571  | 7.569  | 7.575  | 7.571  | 7.573  | 7.569  | 7.567  | 7.570   | 7.548     | 7.592  | 0.022          |
| Methoxychlor       | 9.704                 | 9.707  | 9.705  | 9.711  | 9.708  | 9.709  | 9.705  | 9.703  | 9.707   | 9.679     | 9.734  | 0.028          |
| Endosulfan Sulfate | 8.473                 | 8.476  | 8.475  | 8.479  | 8.476  | 8.479  | 8.475  | 8.471  | 8.476   | 8.451     | 8.500  | 0.024          |
| Endrin Ketone      | 10.103                | 10.105 | 10.104 | 10.108 | 10.107 | 10.108 | 10.104 | 10.101 | 10.105  | 10.075    | 10.135 | 0.030          |
| Oxychlordane       | 4.419                 | 4.420  | 4.421  | 4.413  | 4.415  | 4.420  | 4.420  | 4.415  | 4.418   | 4.398     | 4.438  | 0.020          |
| 2,4'-DDE           | 4.769                 | 4.771  | 4.772  | 4.764  | 4.767  | 4.771  | 4.771  | 4.767  | 4.769   | 4.748     | 4.790  | 0.021          |
| trans-Nonachlor    | 4.908                 | 4.908  | 4.909  | 4.901  | 4.904  | 4.908  | 4.909  | 4.904  | 4.906   | 4.888     | 4.924  | 0.018          |
| 2,4'-DDD           | 5.611                 | 5.612  | 5.612  | 5.604  | 5.607  | 5.611  | 5.612  | 5.607  | 5.609   | 5.591     | 5.627  | 0.018          |
| 2,4'-DDT           | 6.243                 | 6.243  | 6.244  | 6.236  | 6.239  | 6.244  | 6.244  | 6.240  | 6.242   | 6.223     | 6.261  | 0.019          |
| cis-Nonachlor      | 6.328                 | 6.328  | 6.329  | 6.321  | 6.324  | 6.329  | 6.329  | 6.325  | 6.327   | 6.309     | 6.345  | 0.018          |
| Mirex              | 9.928                 | 9.929  | 9.927  | 9.921  | 9.923  | 9.928  | 9.927  | 9.924  | 9.926   | 9.902     | 9.950  | 0.024          |
| SURROGATE          | 1.0X                  | 2.0X   | 4.0X   | 8.0X   | 16.0X  | 32.0X  | 48.0X  | 64.0X  | RT      | FROM      | TO     | WIDTH          |
| TCX                | 2.640                 | 2.643  | 2.640  | 2.647  | 2.644  | 2.644  | 2.643  | 2.641  | 2.643   | 2.620     | 2.666  | 0.023          |
| DCB                | 12.231                | 12.233 | 12.232 | 12.236 | 12.236 | 12.235 | 12.231 | 12.229 | 12.233  | 12.198    | 12.268 | 0.035          |

**Figure 5: TYPICAL PEM PEST BREAKDOWN CALCULATION SUMMARY**

PEM PEST BREAKDOWN CALCULATION  
 METHOD 8081

Lab Name : EMAX  
 Instrument ID : GCT016 HP-5890  
 GC Column : RTX-CLPEST RTX-CLPESTII  
 Column size ID : .32MMX30M .32MMX30M  
 PEM LFID & Datetime : WF17026A WF17026B 06/18/10 00:50

Base on AREA

| LFID     | AREA     |                 |               | TOTAL     | % Breakdown     |               |       | QL | QCLIMIT |
|----------|----------|-----------------|---------------|-----------|-----------------|---------------|-------|----|---------|
|          | DDD      | DDE             | DDT           |           | DDD             | DDE           | TOTAL |    |         |
| WF17026A | 0.0      | 11917.0         | 826713.0      | 838630.0  | 0.00            | 1.42          | 1.42  |    | 15      |
| WF17026B | 21368.0  | 17092.0         | 933363.0      | 971823.0  | 2.20            | 1.76          | 3.96  |    | 15      |
| LFID     | ENDRIN   | ENDRIN ALDEHYDE | ENDRIN KETONE | TOTAL     | ENDRIN ALDEHYDE | ENDRIN KETONE | TOTAL | QL | QCLIMIT |
| WF17026A | 893765.0 | 48233.0         | 35430.0       | 977428.0  | 4.93            | 3.62          | 8.56  |    | 15      |
| WF17026B | 945951.0 | 60214.0         | 48710.0       | 1054875.0 | 5.71            | 4.62          | 10.33 |    | 15      |

**Figure 6: TYPICAL SAMPLE RESULT SUMMARY**

METHOD SW3520C/8081A  
 PESTICIDES

|                         |                                |
|-------------------------|--------------------------------|
| Client : XYZ, INC.      | Date Collected: 01/15/14       |
| Project : CLEAN PROJECT | Date Received: 01/16/14        |
| Batch No. : 14A051      | Date Extracted: 01/21/14 14:00 |
| Sample ID: EMW02012014  | Date Analyzed: 01/28/14 18:09  |
| Lab Samp ID: A051-03    | Dilution Factor: 1             |
| Lab File ID: MA28020A   | Matrix : WATER                 |
| Ext Btch ID: CPA024W    | % Moisture : NA                |
| Calib. Ref.: MA28011A   | Instrument ID : GCE8           |

| PARAMETERS         | RESULTS<br>(ug/L) | LOQ<br>(ug/L) | DL<br>(ug/L) | LOD<br>(ug/L) |
|--------------------|-------------------|---------------|--------------|---------------|
| ALPHA-BHC          | (ND) ND           | 0.10          | 0.0050       | 0.010         |
| GAMMA-BHC          | (ND) ND           | 0.10          | 0.0050       | 0.010         |
| BETA-BHC           | (ND) ND           | 0.10          | 0.0070       | 0.010         |
| HEPTACHLOR         | (ND) ND           | 0.10          | 0.0050       | 0.010         |
| DELTA-BHC          | (ND) ND           | 0.10          | 0.0070       | 0.010         |
| ALDRIN             | (ND) ND           | 0.10          | 0.0050       | 0.010         |
| HEPTACHLOR EPOXIDE | (ND) ND           | 0.10          | 0.0050       | 0.010         |
| GAMMA-CHLORDANE    | (ND) ND           | 0.10          | 0.0050       | 0.010         |
| ALPHA-CHLORDANE    | (ND) ND           | 0.10          | 0.0050       | 0.010         |
| ENDOSULFAN I       | (ND) ND           | 0.10          | 0.0080       | 0.010         |
| 4,4'-DDE           | (ND) ND           | 0.10          | 0.0050       | 0.010         |
| DIELDRIN           | (ND) ND           | 0.10          | 0.0050       | 0.010         |
| ENDRIN             | (ND) ND           | 0.10          | 0.0080       | 0.010         |
| 4,4'-DDD           | (ND) ND           | 0.10          | 0.0050       | 0.010         |
| ENDOSULFAN II      | (ND) ND           | 0.10          | 0.0050       | 0.010         |
| 4,4'-DDT           | (ND) ND           | 0.10          | 0.0050       | 0.010         |
| ENDRIN ALDEHYDE    | (ND) ND           | 0.10          | 0.0050       | 0.010         |
| ENDOSULFAN SULFATE | (ND) ND           | 0.10          | 0.0050       | 0.010         |
| ENDRIN KETONE      | (ND) ND           | 0.10          | 0.0050       | 0.010         |
| METHOXYCHLOR       | (ND) ND           | 1.0           | 0.050        | 0.10          |
| TOXAPHENE          | (ND) ND           | 2.0           | 0.25         | 0.50          |
| CHLORDANE          | (ND) ND           | 1.0           | 0.12         | 0.25          |

| SURROGATE PARAMETERS | RESULTS           | SPK_AMT | % RECOVERY    | QC LIMIT |
|----------------------|-------------------|---------|---------------|----------|
| TETRACHLORO-M-XYLENE | (0.3346)   0.3344 | 0.4000  | (83.7)   83.6 | 25-140   |
| DECACHLOROBIPHENYL   | (0.4240)   0.4139 | 0.4000  | (106)   103   | 30-135   |

RL : Reporting limit  
 Left of | is related to first column ; Right of | related to second column  
 Final result indicated by ( )



Figure 7:

TYPICAL LCS/LCSD REPORT SUMMARY

EMAX QUALITY CONTROL DATA  
LCS/LCSD ANALYSIS

CLIENT: XYZ, INC.  
PROJECT: CLEAN PROJECT  
BATCH NO.: 14A051  
METHOD: SW3520C/8081A

MATRIX: WATER % MOISTURE: NA  
DILUTION FACTOR: 1 1 1  
SAMPLE ID: MBLK1W  
LAB SAMP ID: CPA024WB CPA024WL CPA024WC  
LAB FILE ID: MA28015A MA28016A MA28017A  
DATE EXTRACTED: 01/21/1414:00 01/21/1414:00 01/21/1414:00 DATE COLLECTED: NA  
DATE ANALYZED: 01/28/1416:27 01/28/1416:47 01/28/1417:08 DATE RECEIVED: 01/21/14  
PREP. BATCH: CPA024W CPA024W CPA024W  
CALIB. REF: MA28011A MA28011A MA28011A

ACCESSION:

| PARAMETER          | BLNK RSLT<br>(ug/L) | SPIKE AMT<br>(ug/L) | BS RSLT<br>(ug/L) | BS<br>% REC | SPIKE AMT<br>(ug/L) | BSD RSLT<br>(ug/L) | BSD<br>% REC | RPD<br>(%) | QC LIMIT<br>(%) | MAX RPD<br>(%) |
|--------------------|---------------------|---------------------|-------------------|-------------|---------------------|--------------------|--------------|------------|-----------------|----------------|
| alpha-BHC          | (ND) ND             | 0.200               | (0.203) 0.189     | (101) 94    | 0.200               | (0.204) 0.190      | (102) 95     | (0) 1      | 60-130          | 30             |
| gamma-BHC          | (ND) ND             | 0.200               | (0.202) 0.198     | (101) 99    | 0.200               | (0.202) 0.199      | (101) 100    | (0) 1      | 25-135          | 30             |
| beta-BHC           | (ND) ND             | 0.200               | 0.206 (0.213)     | 103 (106)   | 0.200               | 0.204 (0.214)      | 102 (107)    | 1 (0)      | 65-125          | 30             |
| Heptachlor         | (ND) ND             | 0.200               | 0.204 (0.208)     | 102 (104)   | 0.200               | 0.203 (0.206)      | 101 (103)    | 0 (1)      | 40-130          | 30             |
| delta-BHC          | (ND) ND             | 0.200               | (0.212) 0.204     | (106) 102   | 0.200               | (0.210) 0.203      | (105) 101    | (1) 0      | 45-135          | 30             |
| Aldrin             | (ND) ND             | 0.200               | (0.210) 0.205     | (105) 102   | 0.200               | (0.208) 0.204      | (104) 102    | (1) 0      | 25-140          | 30             |
| Heptachlor Epoxide | (ND) ND             | 0.200               | (0.221) 0.216     | (110) 108   | 0.200               | 0.212 (0.215)      | 106 (108)    | 4 (0)      | 60-130          | 30             |
| gamma-Chlordane    | (ND) ND             | 0.200               | 0.215 (0.218)     | 108 (109)   | 0.200               | 0.213 (0.218)      | 106 (109)    | 1 (0)      | 60-125          | 30             |
| alpha-Chlordane    | (ND) ND             | 0.200               | (0.219) 0.212     | (110) 106   | 0.200               | (0.217) 0.210      | (108) 105    | (1) 1      | 65-125          | 30             |
| Endosulfan I       | (ND) ND             | 0.200               | (0.208) 0.204     | (104) 102   | 0.200               | (0.208) 0.202      | (104) 101    | (0) 1      | 50-110          | 30             |
| 4,4'-DDE           | (ND) ND             | 0.200               | (0.224) 0.212     | (112) 106   | 0.200               | (0.221) 0.207      | (110) 104    | (1) 2      | 35-140          | 30             |
| Dieldrin           | (ND) ND             | 0.200               | (0.213) 0.212     | (106) 106   | 0.200               | (0.212) 0.209      | (106) 104    | (0) 1      | 60-130          | 30             |
| Endrin             | (ND) ND             | 0.200               | (0.228) 0.224     | (114) 112   | 0.200               | (0.229) 0.221      | (114) 110    | (0) 1      | 55-135          | 30             |
| 4,4'-DDD           | (ND) ND             | 0.200               | 0.217 (0.227)     | 108 (114)   | 0.200               | 0.213 (0.223)      | 106 (112)    | 2 (2)      | 25-150          | 30             |
| Endosulfan II      | (ND) ND             | 0.200               | (0.215) 0.209     | (108) 104   | 0.200               | (0.213) 0.207      | (106) 104    | (1) 1      | 30-130          | 30             |
| 4,4'-DDT           | (ND) ND             | 0.200               | (0.255) 0.244     | (127) 122   | 0.200               | (0.253) 0.242      | (126) 121    | (1) 1      | 45-140          | 30             |
| Endrin aldehyde    | (ND) ND             | 0.200               | (0.213) 0.202     | (106) 101   | 0.200               | (0.211) 0.208      | (105) 104    | (1) 3      | 55-135          | 30             |
| Endosulfan Sulfate | (ND) ND             | 0.200               | (0.226) 0.219     | (113) 110   | 0.200               | (0.225) 0.217      | (112) 108    | (0) 1      | 55-135          | 30             |
| Endrin ketone      | (ND) ND             | 0.200               | 0.208 (0.211)     | 104 (105)   | 0.200               | 0.207 (0.209)      | 104 (104)    | 0 (1)      | 75-125          | 30             |
| Methoxychlor       | (ND) ND             | 2.00                | 2.30 (2.88)       | 115 (144)   | 2.00                | 2.28 (2.68)        | 114 (134)    | 1 (7)      | 55-150          | 30             |

| SURROGATE PARAMETER  | SPIKE AMT<br>(ug/L) | BS RSLT<br>(ug/L) | BS<br>% REC | SPIKE AMT<br>(ug/L) | BSD RSLT<br>(ug/L) | BSD<br>% REC | QC LIMIT<br>(%) |
|----------------------|---------------------|-------------------|-------------|---------------------|--------------------|--------------|-----------------|
| Tetrachloro-m-xylene | 0.4000              | (0.3778) 0.3682   | (94.4) 92.0 | 0.4000              | (0.3608) 0.3530    | (90.2) 88.3  | 25-140          |
| Decachlorobiphenyl   | 0.4000              | (0.4321) 0.4309   | (108) 108   | 0.4000              | (0.4262) 0.4226    | (107) 106    | 30-135          |

Figure 8:

TYPICAL MS/MSD REPORT SUMMARY

EMAX QUALITY CONTROL DATA  
 MS/MSD ANALYSIS

CLIENT: XYZ, INC.  
 PROJECT: CLEAN PROJECT  
 BATCH NO.: 14A051  
 METHOD: SW3520C/8081A

MATRIX: WATER % MOISTURE: NA  
 DILUTION FACTOR: 1 1.1 1.02  
 SAMPLE ID: EMW02012014  
 LAB SAMP ID: A051-03 A051-03M A051-03S  
 LAB FILE ID: MA28020A MA28021A MA28022A  
 DATE EXTRACTED: 01/21/1414:00 01/21/1414:00 01/21/1414:00 DATE COLLECTED: 01/15/14  
 DATE ANALYZED: 01/28/1418:09 01/28/1418:29 01/28/1418:50 DATE RECEIVED: 01/16/14  
 PREP. BATCH: CPA024W CPA024W CPA024W  
 CALIB. REF: MA28011A MA28011A MA28011A

ACCESSION:

| PARAMETER          | SMPL RSLT (ug/L) |    | SPIKE AMT (ug/L) | MS RSLT (ug/L) |         | MS % REC | SPIKE AMT (ug/L) | MSD RSLT (ug/L) |         | MSD % REC | RPD ( % ) | QC LIMIT ( % ) | MAX RPD ( % ) |     |        |    |
|--------------------|------------------|----|------------------|----------------|---------|----------|------------------|-----------------|---------|-----------|-----------|----------------|---------------|-----|--------|----|
| alpha-BHC          | (ND)             | ND | 0.220            | (0.232)        | 0.217   | (105)    | 99               | 0.204           | (0.215) | 0.201     | (105)     | 99             | (8)           | 8   | 60-130 | 30 |
| gamma-BHC          | (ND)             | ND | 0.220            | 0.227          | (0.230) | 103      | (105)            | 0.204           | (0.211) | 0.211     | (103)     | 103            | (7)           | 9   | 25-135 | 30 |
| beta-BHC           | (ND)             | ND | 0.220            | 0.228          | (0.253) | 104      | (115)            | 0.204           | 0.210   | (0.231)   | 103       | (113)          | 8             | (9) | 65-125 | 30 |
| Heptachlor         | (ND)             | ND | 0.220            | 0.230          | (0.236) | 105      | (107)            | 0.204           | 0.211   | (0.217)   | 103       | (106)          | 9             | (8) | 40-130 | 30 |
| delta-BHC          | (ND)             | ND | 0.220            | (0.235)        | 0.234   | (107)    | 106              | 0.204           | (0.217) | 0.215     | (106)     | 105            | (8)           | 8   | 45-135 | 30 |
| Aldrin             | (ND)             | ND | 0.220            | (0.236)        | 0.236   | (107)    | 107              | 0.204           | (0.218) | 0.218     | (107)     | 107            | (8)           | 8   | 25-140 | 30 |
| Heptachlor Epoxide | (ND)             | ND | 0.220            | 0.241          | (0.243) | 110      | (110)            | 0.204           | (0.233) | 0.223     | (114)     | 109            | (3)           | 9   | 60-130 | 30 |
| gamma-Chlordane    | (ND)             | ND | 0.220            | (0.243)        | 0.243   | (110)    | 110              | 0.204           | (0.225) | 0.225     | (110)     | 110            | (8)           | 8   | 60-125 | 30 |
| alpha-Chlordane    | (ND)             | ND | 0.220            | (0.249)        | 0.237   | (113)    | 108              | 0.204           | (0.229) | 0.221     | (112)     | 108            | (8)           | 7   | 65-125 | 30 |
| Endosulfan I       | (ND)             | ND | 0.220            | (0.235)        | 0.227   | (107)    | 103              | 0.204           | (0.217) | 0.211     | (106)     | 103            | (8)           | 7   | 50-110 | 30 |
| 4,4'-DDE           | (ND)             | ND | 0.220            | (0.252)        | 0.234   | (115)    | 106              | 0.204           | (0.232) | 0.219     | (114)     | 107            | (8)           | 7   | 35-140 | 30 |
| Dieldrin           | (ND)             | ND | 0.220            | (0.245)        | 0.239   | (111)    | 109              | 0.204           | (0.227) | 0.221     | (111)     | 108            | (8)           | 8   | 60-130 | 30 |
| Endrin             | (ND)             | ND | 0.220            | (0.261)        | 0.253   | (119)    | 115              | 0.204           | (0.240) | 0.235     | (118)     | 115            | (8)           | 7   | 55-135 | 30 |
| 4,4'-DDD           | (ND)             | ND | 0.220            | 0.246          | (0.256) | 112      | (116)            | 0.204           | 0.227   | (0.238)   | 111       | (117)          | 8             | (7) | 25-150 | 30 |
| Endosulfan II      | (ND)             | ND | 0.220            | (0.242)        | 0.235   | (110)    | 107              | 0.204           | (0.225) | 0.218     | (110)     | 107            | (7)           | 8   | 30-130 | 30 |
| 4,4'-DDT           | (ND)             | ND | 0.220            | (0.292)        | 0.278   | (133)    | 126              | 0.204           | (0.271) | 0.257     | (133)     | 126            | (7)           | 8   | 45-140 | 30 |
| Endrin aldehyde    | (ND)             | ND | 0.220            | (0.240)        | 0.236   | (109)    | 107              | 0.204           | (0.222) | 0.214     | (109)     | 105            | (8)           | 10  | 55-135 | 30 |
| Endosulfan Sulfate | (ND)             | ND | 0.220            | (0.257)        | 0.249   | (117)    | 113              | 0.204           | (0.238) | 0.230     | (117)     | 113            | (8)           | 8   | 55-135 | 30 |
| Endrin Ketone      | (ND)             | ND | 0.220            | 0.235          | (0.240) | 107      | (109)            | 0.204           | 0.220   | (0.223)   | 108       | (109)          | 7             | (7) | 75-125 | 30 |
| Methoxychlor       | (ND)             | ND | 2.20             | 2.62           | (3.05)  | 119      | (139)            | 2.04            | 2.43    | (2.82)    | 119       | (138)          | 8             | (8) | 55-150 | 30 |

| SURROGATE PARAMETER  | SPIKE AMT (ug/L) | MS RSLT (ug/L)    | MS % REC      | SPIKE AMT (ug/L) | MSD RSLT (ug/L)   | MSD % REC     | QC LIMIT ( % ) |
|----------------------|------------------|-------------------|---------------|------------------|-------------------|---------------|----------------|
| Tetrachloro-m-xylene | 0.4400           | (0.4345)   0.4180 | (98.7)   95.0 | 0.4080           | (0.3784)   0.3710 | (92.7)   90.9 | 25-140         |
| Decachlorobiphenyl   | 0.4400           | (0.4836)   0.4728 | (110)   107   | 0.4080           | (0.4427)   0.4327 | (109)   106   | 30-135         |

\* : Out side of QC Limit.

Figure 9:

TYPICAL CASE NARRATIVE

---

CASE NARRATIVE

Client : XYZ, INC.  
Project : CLEAN PROJECT  
SDG : 14A051

METHOD SW3520C/8081A  
PESTICIDES

A total of three (3) water samples were received on 01/16/14 for Pesticides Organochlorine analysis, Method SW3520C/8081A in accordance with Department of Defense Quality Systems Manual for Environmental Laboratories, Version 4.2 and Project QAPP 5/2012.

Holding Time

Samples were analyzed within the prescribed holding time.

Instrument Performance and Calibration

Instrument performance was checked prior to calibration. DDT and Endrin breakdown were within specification. Multi-calibration points were generated to establish initial calibration (ICAL). ICAL was verified using secondary source (ICV). Continuing calibration (CCV) was carried on at a frequency required by the project. All project calibration requirements were satisfied. Refer to calibration summary forms of ICAL, ICV and CCV for details.

Method Blank

Method blank was analyzed at the frequency required by the project. For this SDG, one method blank was analyzed with the samples. Result was compliant to project requirement.

Lab Control Sample

A set of LCS/LCD was analyzed with the samples in this SDG. Percent recoveries for CPA024WL/C were all within QC limits.

Matrix QC Sample

A set of MS/MSD was analyzed with the samples in this SDG. Percent recoveries for A051-03M/S were within project QC limits.

Surrogate

Surrogates were added on QC and field samples. Surrogate recoveries were within project QC limits. Refer to sample result forms for details.

Sample Analysis

Samples were analyzed according to prescribed analytical procedures. All project requirements were met; otherwise, anomalies were discussed within the associated QC parameter. Positive sample results were confirmed by a second column. Relative percentage difference (RPD) between the two results was evaluated. If RPD is less than 40% and peaks are well defined the higher result is reported. Where RPD is greater than 40% the chromatogram is checked for anomalies and results are selected based on processed knowledge. If there is no evidence of any chromatographic ambiguity, the higher result is reported.

**Table 1: ICAL CONCENTRATION OF INDIVIDUAL ANALYTES**

| PARAMETERS                       | ICAL STANDARD CONCENTRATION (µg/L) |     |     |     |     |      |      |      |
|----------------------------------|------------------------------------|-----|-----|-----|-----|------|------|------|
|                                  | 1                                  | 2   | 3   | 4   | 5   | 6    | 7    | 8    |
| <b>PESTICIDES</b>                |                                    |     |     |     |     |      |      |      |
| Aldrin                           | 1.25                               | 2.5 | 5   | 10  | 20  | 40   | 60   | 80   |
| alpha-BHC                        | 1.25                               | 2.5 | 5   | 10  | 20  | 40   | 60   | 80   |
| beta-BHC                         | 1.25                               | 2.5 | 5   | 10  | 20  | 40   | 60   | 80   |
| delta-BHC                        | 1.25                               | 2.5 | 5   | 10  | 20  | 40   | 60   | 80   |
| gamma-BHC                        | 1.25                               | 2.5 | 5   | 10  | 20  | 40   | 60   | 80   |
| alpha-Chlordane                  | 1.25                               | 2.5 | 5   | 10  | 20  | 40   | 60   | 80   |
| gamma-Chlordane                  | 1.25                               | 2.5 | 5   | 10  | 20  | 40   | 60   | 80   |
| Heptachlor                       | 1.25                               | 2.5 | 5   | 10  | 20  | 40   | 60   | 80   |
| Heptachlor Epoxide               | 1.25                               | 2.5 | 5   | 10  | 20  | 40   | 60   | 80   |
| Endosulfan I                     | 1.25                               | 2.5 | 5   | 10  | 20  | 40   | 60   | 80   |
| 4,4' – DDD                       | 2.5                                | 5   | 10  | 20  | 40  | 80   | 120  | 160  |
| 4,4' – DDE                       | 2.5                                | 5   | 10  | 20  | 40  | 80   | 120  | 160  |
| 4,4' – DDT                       | 2.5                                | 5   | 10  | 20  | 40  | 80   | 120  | 160  |
| Dieldrin                         | 2.5                                | 5   | 10  | 20  | 40  | 80   | 120  | 160  |
| Endrin                           | 2.5                                | 5   | 10  | 20  | 40  | 80   | 120  | 160  |
| Endosulfan II                    | 2.5                                | 5   | 10  | 20  | 40  | 80   | 120  | 160  |
| Endosulfan Sulfate               | 2.5                                | 5   | 10  | 20  | 40  | 80   | 120  | 160  |
| Endrin Aldehyde                  | 2.5                                | 5   | 10  | 20  | 40  | 80   | 120  | 160  |
| Endrin Ketone                    | 2.5                                | 5   | 10  | 20  | 40  | 80   | 120  | 160  |
| Methoxychlor                     | 12.5                               | 25  | 50  | 100 | 200 | 400  | 600  | 800  |
| 2,4' – DDD                       | 1.25                               | 2.5 | 5   | 10  | 20  | 40   | 60   | 80   |
| 2,4' – DDE                       | 1.25                               | 2.5 | 5   | 10  | 20  | 40   | 60   | 80   |
| 2,4' – DDT                       | 1.25                               | 2.5 | 5   | 10  | 20  | 40   | 60   | 80   |
| Oxychlordane                     | 1.25                               | 2.5 | 5   | 10  | 20  | 40   | 60   | 80   |
| cis-Nonachlor                    | 1.25                               | 2.5 | 5   | 10  | 20  | 40   | 60   | 80   |
| Trans-Nonachlor                  | 1.25                               | 2.5 | 5   | 10  | 20  | 40   | 60   | 80   |
| Mirex                            | 1.25                               | 2.5 | 5   | 10  | 20  | 40   | 60   | 80   |
| Tetrachloro-m-xylene (surrogate) | 1.25                               | 2.5 | 5   | 10  | 20  | 40   | 60   | 80   |
| Decachlorobiphenyl (Surrogate)   | 1.25                               | 2.5 | 5   | 10  | 20  | 40   | 60   | 80   |
| TOXAPHENE                        | 50                                 | 100 | 250 | 500 | 750 | 1000 | 1500 | 2000 |
| TECHNICAL CHLORDANE              | 25                                 | 100 | 250 | 500 | 750 | 1000 | 1500 | 2000 |

**Table 2: ICAL STANDARD PREPARATION**

| Standard #                 | Compound Name        | Intermediate Solution Conc.<br>(µg/L) | Preparation  |         |                   | Final Conc. (µg/L) |
|----------------------------|----------------------|---------------------------------------|--------------|---------|-------------------|--------------------|
|                            |                      |                                       | Aliquot (µL) | Solvent | Final Volume (µL) |                    |
| <b>PESTICIDES</b>          |                      |                                       |              |         |                   |                    |
| 1                          | Pest ICAL Mix1       | 80 / 160 / 800                        | 12.5         | Hexane  | 800               | 1.25 / 2.5 / 12.5  |
| 2                          | Pest ICAL Mix1       | 80 / 160 / 800                        | 25           | Hexane  | 800               | 2.5 / 5 / 25       |
| 3                          | Pest ICAL Mix1       | 80 / 160 / 800                        | 50           | Hexane  | 800               | 5 / 10 / 50        |
| 4                          | Pest ICAL Mix1       | 80 / 160 / 800                        | 100          | Hexane  | 800               | 10 / 20 / 100      |
| 5                          | Pest ICAL Mix1       | 80 / 160 / 800                        | 200          | Hexane  | 800               | 20 / 40 / 200      |
| 6                          | Pest ICAL Mix1       | 80 / 160 / 800                        | 400          | Hexane  | 800               | 40 / 80 / 400      |
| 7                          | Pest ICAL Mix1       | 80 / 160 / 800                        | 600          | Hexane  | 800               | 60 / 120 / 600     |
| 8                          | Pest ICAL Mix1       | 80 / 160 / 800                        | 800          | -       | 800               | 80 / 160 / 800     |
| <b>TOXAPHENE</b>           |                      |                                       |              |         |                   |                    |
| 1                          | Toxaphene ICAL       | 2000                                  | 20           | Hexane  | 800               | 50                 |
| 2                          | Toxaphene ICAL       | 2000                                  | 40           | Hexane  | 800               | 100                |
| 3                          | Toxaphene ICAL       | 2000                                  | 100          | Hexane  | 800               | 250                |
| 4                          | Toxaphene ICAL       | 2000                                  | 200          | Hexane  | 800               | 500                |
| 5                          | Toxaphene ICAL       | 2000                                  | 300          | Hexane  | 800               | 750                |
| 6                          | Toxaphene ICAL       | 2000                                  | 400          | Hexane  | 800               | 1000               |
| 7                          | Toxaphene ICAL       | 2000                                  | 600          | Hexane  | 800               | 1500               |
| 8                          | Toxaphene ICAL       | 2000                                  | 800          | -       | 800               | 2000               |
| <b>TECHNICAL CHLORDANE</b> |                      |                                       |              |         |                   |                    |
| 1                          | Tech. Chlordane ICAL | 2000                                  | 10           | Hexane  | 800               | 25                 |
| 2                          | Tech. Chlordane ICAL | 2000                                  | 40           | Hexane  | 800               | 100                |
| 3                          | Tech. Chlordane ICAL | 2000                                  | 100          | Hexane  | 800               | 250                |
| 4                          | Tech. Chlordane ICAL | 2000                                  | 200          | Hexane  | 800               | 500                |
| 5                          | Tech. Chlordane ICAL | 2000                                  | 300          | Hexane  | 800               | 750                |
| 6                          | Tech. Chlordane ICAL | 2000                                  | 400          | Hexane  | 800               | 1000               |
| 7                          | Tech. Chlordane ICAL | 2000                                  | 600          | Hexane  | 800               | 1500               |
| 8                          | Tech. Chlordane ICAL | 2000                                  | 800          | -       | 800               | 2000               |
| <b>PESTICIDES MIX 3</b>    |                      |                                       |              |         |                   |                    |
| 1                          | Pest ICAL Mix 3      | 80                                    | 12.5         | Hexane  | 800               | 1.25               |
| 2                          | Pest ICAL Mix 3      | 80                                    | 25           | Hexane  | 800               | 2.5                |
| 3                          | Pest ICAL Mix 3      | 80                                    | 50           | Hexane  | 800               | 5                  |
| 4                          | Pest ICAL Mix 3      | 80                                    | 100          | Hexane  | 800               | 10                 |
| 5                          | Pest ICAL Mix 3      | 80                                    | 200          | Hexane  | 800               | 20                 |
| 6                          | Pest ICAL Mix 3      | 80                                    | 400          | Hexane  | 800               | 40                 |
| 7                          | Pest ICAL Mix 3      | 80                                    | 600          | Hexane  | 800               | 60                 |
| 8                          | Pest ICAL Mix 3      | 80                                    | 800          | -       | 800               | 80                 |

**Table 3: INTERMEDIATE PRIMARY STANDARD PREPARATION**

| <b>PESTICIDES MIX 1: RESTEK</b>          | <b>Stock Std. Conc. (µg/mL)</b> | <b>Final Conc. (µg/L)</b> | <b>Preparation</b>  |
|--|---------------------------------|---------------------------|---|
| Aldrin                                   | 8                               | 80                        | Using a gas-tight syringe, measure 1000 µL of (Restek) Pesticides Mix 1 and 40 µL of (Supelco) Pest Surrogate and dilute with hexane to 100 mL.                   |
| alpha-BHC                                | 8                               | 80                        |   |
| beta-BHC                                 | 8                               | 80                        |   |
| delta-BHC                                | 8                               | 80                        |   |
| gamma-BHC                                | 8                               | 80                        |   |
| alpha-Chlordane                          | 8                               | 80                        |   |
| gamma-Chlordane                          | 8                               | 80                        |   |
| Heptachlor                               | 8                               | 80                        |   |
| Heptachlor Epoxide                       | 8                               | 80                        |   |
| Endosulfan I                             | 8                               | 80                        |   |
| 4,4'-DDD                                 | 16                              | 160                       |   |
| 4,4'-DDE                                 | 16                              | 160                       |   |
| 4,4'-DDT                                 | 16                              | 160                       |   |
| Dieldrin                                 | 16                              | 160                       |   |
| Endrin                                   | 16                              | 160                       |   |
| Endosulfan II                            | 16                              | 160                       |   |
| Endosulfan Sulfate                       | 16                              | 160                       |   |
| Endrin Aldehyde                          | 16                              | 160                       |   |
| Endrin Ketone                            | 16                              | 160                       |   |
| Methoxychlor                             | 80                              | 800                       |   |
| <b>Surrogate: SUPELCO</b>                |                                 |                           |   |
| Tetrachloro-m-xylene                     | 200                             | 80                        |   |
| Decachlorobiphenyl                       | 200                             | 80                        |   |
| <b>TOXAPHENE: AccuStandard</b>           |                                 |                           |   |
| Toxaphene                                | 1000                            | 2000                      | Using a gas-tight syringe, measure 200 µL of (AccuStandard) Toxaphene standard and 50 µL of (Supelco) Pest Surrogate and dilute with hexane to 100 mL.            |
| <b>Surrogate: SUPELCO</b>                |                                 |                           |   |
| Tetrachloro-m-xylene                     | 200                             | 100                       |   |
| Decachlorobiphenyl                       | 200                             | 100                       |   |
| <b>TECHNICAL CHLORDANE: AccuStandard</b> |                                 |                           |   |
| Technical Chlordane                      | 1000                            | 2000                      | Using a gas-tight syringe, measure 200 µL of (AccuStandard) Tech. Chlordane standard and 50 µL of (AccuStandard) Pest Surrogate and dilute with hexane to 100 mL. |
| <b>Surrogate: SUPELCO</b>                |                                 |                           |   |
| Tetrachloro-m-xylene                     | 200                             | 100                       |   |
| Decachlorobiphenyl                       | 200                             | 100                       |   |
| <b>PESTICIDES MIX 3: SPEXCERTIPREP</b>   |                                 |                           |   |
| 2,4'-DDD                                 | 1000                            | 80                        | Using a gas-tight syringe, measure 8 µL of (SpexCertiPrep) Pesticides Mix3 and dilute with hexane to 100 mL.  |
| 2,4'-DDE                                 | 1000                            | 80                        |   |
| 2,4'-DDT                                 | 1000                            | 80                        |   |
| Oxychlordane                             | 1000                            | 80                        |   |
| cis-Nanochlordane                        | 1000                            | 80                        |   |
| trans-Nanochlordane                      | 1000                            | 80                        |   |
| Mirex                                    | 1000                            | 80                        |   |

**Table 4: INTERMEDIATE SECONDARY STANDARD PREPARATION**

| <b>PESTICIDES MIX 1: SUPELCO</b>                    | Stock Std. Conc. (µg/mL) | Final Conc. (µg/L) | Preparation  |
|---|--------------------------|--------------------|--|
| Aldrin  | 2000                     | 200                | Using a gas-tight syringe, measure 10 µL of (Supelco) Pesticides Mix and 180 µL of (SpexCertiPrep) Methoxychlor and dilute with hexane to 100 mL.                  |
| alpha-BHC   | 2000                     | 200                |  |
| beta-BHC  | 2000                     | 200                |  |
| delta-BHC   | 2000                     | 200                |  |
| gamma-BHC   | 2000                     | 200                |  |
| alpha-Chlordane                                     | 2000                     | 200                |  |
| gamma-Chlordane                                     | 2000                     | 200                |  |
| Heptachlor  | 2000                     | 200                |  |
| Heptachlor Epoxide                                  | 2000                     | 200                |  |
| Endosulfan I  | 2000                     | 200                |  |
| 4,4'-DDD  | 2000                     | 200                |  |
| 4,4'-DDE  | 2000                     | 200                |  |
| 4,4'-DDT  | 2000                     | 200                |  |
| Dieldrin  | 2000                     | 200                |  |
| Endrin  | 2000                     | 200                |  |
| Endosulfan II                                       | 2000                     | 2002               |  |
| Endosulfan Sulfate                                  | 2000                     | 200                |  |
| Endrin Aldehyde                                     | 2000                     | 200                |  |
| Endrin Ketone                                       | 2000                     | 200                |  |
| Methoxychlor  | 2000                     | 2000               |  |
| Methoxychlor ( <i>SpexCertiPrep</i> )               | 1000                     |                    |  |
| Tetrachloro-m-xylene                                | 200                      | 200                |  |
| Decachlorobiphenyl                                  | 200                      | 200                |  |
| <b>TOXAPHENE: <i>Ultra Scientific</i></b>           |                          |                    |  |
| Toxaphene   | 2500                     | 2000               | Using a gas-tight syringe, measure 20 µL of (Ultra Scientific) Toxaphene standard and 12.5 µL of (Supelco) Pest Surrogate and dilute with hexane to 25 mL.         |
| Tetrachloro-m-xylene                                | 200                      | 100                |  |
| Decachlorobiphenyl                                  | 200                      | 100                |  |
| <b>TECHNICAL CHLORDANE: <i>Ultra Scientific</i></b> |                          |                    |  |
| Technical Chlordane                                 | 100                      | 2000               | Using a gas-tight syringe, measure 500 µL of (Ultra Scientific) Tech. Chlordane standard and 12.5 µL of (Supelco) Pest Surrogate and dilute with hexane to 100 mL. |
| Tetrachloro-m-xylene                                | 200                      | 100                |  |
| Decachlorobiphenyl                                  | 200                      | 100                |  |
| <b>PESTICIDES MIX 3: <i>CPI</i></b>                 |                          |                    |  |
| 2,4'-DDD  | 1000                     | 80                 | Using a gas-tight syringe, measure 4 µL of (CPI) Pesticides Mix3 and 40 µL of (AccuStandard) Mirex and dilute with hexane to 100 mL.                               |
| 2,4'-DDE  | 1000                     | 80                 |  |
| 2,4'-DDT  | 1000                     | 80                 |  |
| Oxychlordane  | 1000                     | 80                 |  |
| cis-Nanochlordane                                   | 100                      | 80                 |  |
| trans-Nanochlordane                                 | 100                      | 80                 |  |
| Mirex ( <i>AccuStandard</i> )                       | 100                      | 80                 |  |

**Note:** Table 2 and Table 2A may be interchanged. However, the source of LCS shall follow the source of the secondary standard or from a third vendor.

**Table 5: CHECK STANDARD PREPARATION (DCC/ICV)**

| Standard                   | Compound Name  | Intermediate Soln. Conc. (µg/L) | Source                  | Preparation  |                     |                 | Final Conc. (µg/L) |
|----------------------------|----------------|---------------------------------|-------------------------|--------------|---------------------|-----------------|--------------------|
|                            |                |                                 |                         | Aliquot (µL) | Dil.Soln./ Modifier | Final Vol. (µL) |                    |
| <b>PESTICIDES</b>          |                |                                 |                         |              |                     |                 |                    |
| DCC                        | Pest ICAL Mix  | 80/160/800                      | Restek                  | 200          | Hexane              | 800             | 20/40/200          |
|                            | Surrogate Mix  | 80                              | AccuStandard            |              |                     |                 | 20                 |
| ICV                        | Pest ICV Mix   | 200/2000                        | Supelco / SpexCertiPrep | 100          | Hexane              | 1000            | 20/200             |
|                            | Surrogate Mix  | 200                             | Supelco                 |              |                     |                 | 20                 |
| <b>TOXAPHENE</b>           |                |                                 |                         |              |                     |                 |                    |
| DCC                        | Toxaphene ICAL | 2000                            | AccuStandard            | 200          | Hexane              | 800             | 500                |
|                            | Surrogate Mix  | 100                             | AccuStandard            |              |                     |                 | 25                 |
| ICV                        | Toxaphene ICV  | 200                             | Ultra Scientific        | 200          | Hexane              | 800             | 500                |
|                            | Surrogate Mix  | 100                             | Supelco                 |              |                     |                 | 25                 |
| <b>TECHNICAL CHLORDANE</b> |                |                                 |                         |              |                     |                 |                    |
| DCC                        | Toxaphene ICAL | 2000                            | AccuStandard            | 200          | Hexane              | 800             | 500                |
|                            | Surrogate Mix  | 100                             | AccuStandard            |              |                     |                 | 25                 |
| ICV                        | Toxaphene ICV  | 200                             | Ultra Scientific        | 200          | Hexane              | 800             | 500                |
|                            | Surrogate Mix  | 100                             | Supelco                 |              |                     |                 | 25                 |

**Table 6: SURROGATE STANDARD PREPARATION**

| Compound Name   | Stock Soln. Conc. (µg/mL) | Source  | Preparation  |                     |                 | Final Conc. (µg/L) |
|---|---------------------------|---------|--------------|---------------------|-----------------|--------------------|
|   |                           |         | Aliquot (mL) | Dil.Soln./ Modifier | Final Vol. (mL) |                    |
| Surrogate Mix (Tetrachloro-m-xylene & Decachlorobiphenyl) | 200                       | Supelco | 2.0          | Hexane              | 1,000           | 400                |

**Table 7: SPIKE STANDARD PREPARATION**

| Compound Name              | Stock/Intermediate Soln. Conc. (µg/mL) | Source        | Preparation  |                     |                | Final Conc. (µg/L) |
|----------------------------|--|---------------|--------------|---------------------|----------------|--------------------|
|                            |  |               | Aliquot (µL) | Dil.Soln./ Modifier | Dil. Vol. (mL) |                    |
| Pesticide Matrix Spike Mix | 2,000                                  | Supelco       | 20           | Hexane              | 100            | 400/4000           |
| Methoxychlor               | 1,000                                  | SpexCertiPrep | 360          |                     |                |                    |



**Table 8: PERFORMANCE EVALUATION MIXTURE PREPARATION**

| Compound Name          | Stock/Intermediate Soln. Conc. (µg/mL) | Source  | Preparation  |                     |                | Final Conc (µg/L) |
|------------------------|--|---------|--------------|---------------------|----------------|-------------------|
|                        |  |         | Aliquot (µL) | Dil.Soln./ Modifier | Dil. Vol. (mL) |                   |
| PEM (DDT + Endrin Mix) | 500                                    | Supelco | 20           | Hexane              | 100            | 100/100           |

**Table 9: CLP RETENTION TIME WINDOWS (CLP OLM4.2 D-79/PEST)**

| Compound           | Retention Time Window (minutes) | Compound             | Retention Time Window (minutes) |
|--------------------|---------------------------------|----------------------|---------------------------------|
| alpha-BHC          | ± 0.05                          | Endrin Ketone        | ± 0.07                          |
| beta-BHC           | ± 0.05                          | 4,4'-DDD             | ± 0.07                          |
| gamma-BHC(Lindane) | ± 0.05                          | 4,4'-DDE             | ± 0.07                          |
| delta-BHC          | ± 0.05                          | 4,4'-DDT             | ± 0.07                          |
| Heptachlor         | ± 0.05                          | Endosulfan II        | ± 0.07                          |
| Aldrin             | ± 0.05                          | Endosulfan Sulfate   | ± 0.07                          |
| alpha-Chlordane    | ± 0.07                          | Methoxychlor         | ± 0.07                          |
| gamma-Chlordane    | ± 0.07                          | Aroclors             | ± 0.07                          |
| Heptachlor Epoxide | ± 0.07                          | Toxaphene            | ± 0.07                          |
| Dieldrin           | ± 0.07                          |                      |                                 |
| Endrin             | ± 0.07                          | Tetrachloro-m-xylene | ± 0.05                          |
| Endrin Aldehyde    | ± 0.07                          | Decachlorobiphenyl   | ± 0.10                          |

**Table 10: ESTABLISHED LIMIT OF DETECTION (LOD) & LIMIT OF QUANTITATION (LOQ)**

| <b>MATRIX: AQUEOUS</b> | <b>DL</b> | <b>LOD</b> | <b>LOQ</b> | <b>Unit</b> |
|------------------------|-----------|------------|------------|-------------|
| Aldrin                 | 0.005     | 0.01       | 0.1        | µg/L        |
| Alpha-BHC              | 0.005     | 0.01       | 0.1        | µg/L        |
| Beta-BHC               | 0.007     | 0.01       | 0.1        | µg/L        |
| Delta-BHC              | 0.007     | 0.01       | 0.1        | µg/L        |
| Gamma-BHC (Lindane)    | 0.005     | 0.01       | 0.1        | µg/L        |
| DDD (4,4)              | 0.005     | 0.01       | 0.1        | µg/L        |
| DDE (4,4)              | 0.005     | 0.01       | 0.1        | µg/L        |
| DDT (4,4)              | 0.005     | 0.01       | 0.1        | µg/L        |
| Dieldrin               | 0.005     | 0.01       | 0.1        | µg/L        |
| Endosulfan I           | 0.008     | 0.01       | 0.1        | µg/L        |
| Endosulfan II          | 0.005     | 0.01       | 0.1        | µg/L        |
| Endosulfan Sulfate     | 0.005     | 0.01       | 0.1        | µg/L        |
| Endrin                 | 0.008     | 0.01       | 0.1        | µg/L        |
| Endrin Aldehyde        | 0.005     | 0.01       | 0.1        | µg/L        |
| Heptachlor             | 0.007     | 0.01       | 0.1        | µg/L        |
| Heptachlor epoxide     | 0.005     | 0.01       | 0.1        | µg/L        |
| Methoxychlor           | 0.05      | 0.1        | 1          | µg/L        |
| Alpha-Chlordane        | 0.005     | 0.01       | 0.1        | µg/L        |
| Gamma-Chlordane        | 0.005     | 0.01       | 0.1        | µg/L        |
| Endrin Ketone          | 0.005     | 0.01       | 0.1        | µg/L        |
| Toxaphene              | 0.25      | 0.5        | 2          | µg/L        |
| Technical Chlordane    | 0.005     | 0.25       | 1          | µg/L        |
| <b>SURROGATES</b>      |           |            |            |             |
| Tetrachloro-m-xylene   | 0.005     | 0.01       | 0.02       | µg/L        |
| Decachlorobiphenyl     | 0.005     | 0.01       | 0.02       | µg/L        |

*Reference: Detection Limit Study dated April 20,2010.*

| <b>PARAMETER (MATRIX: SOIL)</b> | <b>DL</b> | <b>LOD</b> | <b>LOQ</b> | <b>Unit</b> |
|---------------------------------|-----------|------------|------------|-------------|
| Aldrin                          | 0.02      | 0.4        | 2          | µg/Kg       |
| Alpha-BHC                       | 0.02      | 0.4        | 2          | µg/Kg       |
| Beta-BHC                        | 0.02      | 0.4        | 2          | µg/Kg       |
| Delta-BHC                       | 0.27      | 0.4        | 2          | µg/Kg       |
| Gamma-BHC (Lindane)             | 0.2       | 0.4        | 2          | µg/Kg       |
| DDD (4,4)                       | 0.02      | 0.4        | 2          | µg/Kg       |
| DDE (4,4)                       | 0.02      | 0.4        | 2          | µg/Kg       |
| DDT (4,4)                       | 0.02      | 0.4        | 2          | µg/Kg       |
| Dieldrin                        | 0.02      | 0.4        | 2          | µg/Kg       |
| Endosulfan I                    | 0.2       | 0.4        | 2          | µg/Kg       |
| Endosulfan II                   | 0.2       | 0.4        | 2          | µg/Kg       |
| Endosulfan Sulfate              | 0.2       | 0.4        | 2          | µg/Kg       |
| Endrin                          | 0.2       | 0.4        | 2          | µg/Kg       |
| Endrin Aldehyde                 | 0.35      | 0.4        | 2          | µg/Kg       |
| Heptachlor                      | 0.2       | 0.4        | 2          | µg/Kg       |
| Heptachlor epoxide              | 0.2       | 0.4        | 2          | µg/Kg       |
| Methoxychlor                    | 2         | 4          | 10         | µg/Kg       |
| Alpha-Chlordane                 | 0.2       | 0.4        | 2          | µg/Kg       |
| Gamma-Chlordane                 | 0.2       | 0.4        | 2          | µg/Kg       |
| Endrin Ketone                   | 0.2       | 0.4        | 2          | µg/Kg       |
| Toxaphene                       | 5         | 10         | 50         | µg/Kg       |
| Technical Chlordane             | 10        | 20         | 50         | µg/Kg       |
| <b>SURROGATES</b>               |           |            |            |             |
| Tetrachloro-m-xylene            | 0.167     | 0.33       | 0.7        | µg/Kg       |
| Decachlorobiphenyl              | 0.167     | 0.33       | 0.7        | µg/Kg       |

*Reference: Detection Limit Study dated April 5,2010.*

**Appendix 1:**

**SUMMARY OF QUALITY CONTROL PROCEDURE**

| QC PROCEDURE  | FREQUENCY   | ACCEPTANCE CRITERIA  | CORRECTIVE ACTION   | 1 <sup>st</sup> Rvw | 2 <sup>nd</sup> Rvw |
|---|---|--|---|---------------------|---------------------|
| 5 point Initial Calibration for analytes  | Initially, as needed  | RSD for all analytes $\leq 20\%$ or Linear – least squares or inverse weighting factor: $r \geq 0.995$ .                                     | Correct then problem then repeat initial calibration.   |                     |                     |
| Second –source Calibration Verification   | Once per 5-point initial calibration                                    | All analytes within $\pm 20\%$ of expected value from the ICAL.  | Repeat injection of ICV. If the problem persists, perform troubleshooting and repeat the ICAL.  |                     |                     |
| Initial Calibration Verification Check  | Daily, before sample analysis   | All analytes within $\pm 20\%$   | Correct the problem. If problem persists, repeat initial calibration  |                     |                     |
| Calibration Verification  | Every 12 hours of analysis time and at the end of the analysis sequence | All analytes within $\pm 20\%$   | Correct the problem then repeat initial calibration verification and re-analyze all samples since last successful calibration verification                                |                     |                     |
| Breakdown check (Endrin and DDT)  | Every 12-hours  | Degradation $\leq 15\%$ of each analyte.   | Repeat breakdown check  |                     |                     |
| Method Blank  | One per preparation batch   | No analytes detected $> \frac{1}{2}$ LOQ or $> 1/10$ the amount measured in any sample or $1/10$ the regulatory limit, whichever is greater. | Re-prep and re-analyze method blank and all samples processed with the contaminated blank   |                     |                     |
| LCS   | One LCS per preparation batch   | Within project QC limits   | Re-prep and re-analyze the LCS and all associated samples   |                     |                     |
| Surrogate spike   | Every sample, spiked sample, standard and method blank                  | Within project QC limits   | Correct the problem then re-extract and re-analyze sample   |                     |                     |
| MS/MSD  | One MS/MSD per every 20 project samples per matrix                      | Within project QC limits   | If chromatogram is indicative of matrix interference, discuss in case narrative. Otherwise, check for probable source of error and perform corrective action as necessary |                     |                     |
| Confirmation  | 100% for all positive results   | Same as primary column   | If quantitation criteria are not met, use confirmation for qualitative identification only.   |                     |                     |
| Comments:<br>1. For flagging criteria refer to PSR. Otherwise, if MB is non-compliant, apply B to specific analyte(s) on all associated samples; apply J to all values between LOD and LOQ. |   |  | Reviewed By:  |                     |                     |
|   |   |  | Date  |                     |                     |

**Appendix 2:**

**DEMONSTRATION OF CAPABILITY**

**DEMONSTRATION OF CAPABILITY  
 METHOD: EPA 3520C / EPA 8081B**

Sample Prep SOP: EMAX-3520 Rev. 5  
 Analytical SOP: EMAX-8081  
 Conc Unit: µg/L  
 Sample Amt(ml): 1000  
 Extract Volume (mL): 10

Instrument ID: E8  
 Extraction date: 9/12 & 9/16/13  
 Extracted by: Iragasa / Jmuertigue  
 Analysis date: 9/18 & 9/19/13  
 Analyzed by: E. Santos

| PARAMETER           | CPI018WL   | CPI018WC   | CPI023WL   | CPI023WC   | TV  | Ave. Conc. | Ave. %Rec | SD    | RSD (%) | QC Criteria | COMMENTS |
|---------------------|------------|------------|------------|------------|-----|------------|-----------|-------|---------|-------------|----------|
|                     | RI18020A/B | RI18021A/B | RI18060A/B | RI18061A/B |     |            |           |       |         |             |          |
| Aldrin              | 0.213      | 0.222      | 0.233      | 0.234      | 0.2 | 0.2        | 113       | 0.010 | 4.5     | 70 - 130    | PASSED   |
| alpha-BHC           | 0.219      | 0.231      | 0.250      | 0.245      | 0.2 | 0.2        | 118       | 0.014 | 5.9     | 70 - 140    | PASSED   |
| beta-BHC            | 0.241      | 0.275      | 0.299      | 0.269      | 0.2 | 0.3        | 135       | 0.024 | 8.7     | 70 - 140    | PASSED   |
| delta-BHC           | 0.235      | 0.248      | 0.263      | 0.261      | 0.2 | 0.3        | 126       | 0.013 | 5.3     | 70 - 140    | PASSED   |
| gamma-BHC (Lindane) | 0.205      | 0.213      | 0.228      | 0.227      | 0.2 | 0.2        | 109       | 0.011 | 5.2     | 60 - 140    | PASSED   |
| DDD (4,4)           | 0.217      | 0.223      | 0.244      | 0.237      | 0.2 | 0.2        | 115       | 0.012 | 5.4     | 70 - 140    | PASSED   |
| DDE (4,4)           | 0.215      | 0.224      | 0.238      | 0.234      | 0.2 | 0.2        | 114       | 0.010 | 4.4     | 70 - 130    | PASSED   |
| DDT (4,4)           | 0.240      | 0.251      | 0.269      | 0.256      | 0.2 | 0.3        | 127       | 0.012 | 4.8     | 70 - 150    | PASSED   |
| Dieldrin            | 0.218      | 0.224      | 0.248      | 0.236      | 0.2 | 0.2        | 116       | 0.013 | 5.8     | 70 - 130    | PASSED   |
| Endosulfan I        | 0.206      | 0.213      | 0.228      | 0.224      | 0.2 | 0.2        | 109       | 0.010 | 4.7     | 70 - 130    | PASSED   |
| Endosulfan II       | 0.222      | 0.229      | 0.250      | 0.241      | 0.2 | 0.2        | 118       | 0.013 | 5.3     | 70 - 130    | PASSED   |
| Endosulfan sulfate  | 0.224      | 0.231      | 0.250      | 0.244      | 0.2 | 0.2        | 119       | 0.012 | 5.0     | 70 - 140    | PASSED   |
| Endrin              | 0.217      | 0.225      | 0.238      | 0.228      | 0.2 | 0.2        | 113       | 0.009 | 3.8     | 70 - 140    | PASSED   |
| Endrin Aldehyde     | 0.211      | 0.211      | 0.247      | 0.242      | 0.2 | 0.2        | 114       | 0.019 | 8.5     | 70 - 140    | PASSED   |
| Heptachlor          | 0.208      | 0.218      | 0.226      | 0.225      | 0.2 | 0.2        | 110       | 0.008 | 3.9     | 60 - 130    | PASSED   |
| Heptachlor epoxide  | 0.215      | 0.220      | 0.236      | 0.231      | 0.2 | 0.2        | 113       | 0.010 | 4.3     | 70 - 130    | PASSED   |
| Methoxychlor        | 2.160      | 2.253      | 2.462      | 2.477      | 2   | 2          | 117       | 0.157 | 6.7     | 70 - 140    | PASSED   |
| alpha-Chlordane     | 0.211      | 0.219      | 0.232      | 0.228      | 0.2 | 0.2        | 111       | 0.009 | 4.2     | 70 - 130    | PASSED   |
| gamma-Chlordane     | 0.224      | 0.232      | 0.248      | 0.244      | 0.2 | 0.2        | 119       | 0.011 | 4.6     | 70 - 140    | PASSED   |
| Endrin Ketone       | 0.223      | 0.221      | 0.240      | 0.236      | 0.2 | 0.2        | 115       | 0.009 | 4.1     | 70 - 130    | PASSED   |
| Tcx                 | 0.365      | 0.396      | 0.398      | 0.406      | 0.4 | 0.4        | 98        | 0.018 | 4.6     | 30 - 130    | PASSED   |
| DCB                 | 0.356      | 0.368      | 0.368      | 0.367      | 0.4 | 0.4        | 91        | 0.006 | 1.6     | 60 - 130    | PASSED   |

**Appendix 2:**

**DEMONSTRATION OF CAPABILITY**

**DEMONSTRATION OF CAPABILITY**

**METHOD: EPA 3550C / EPA 8081B**

Sample Prep SOP: EMAX-3550 Rev. 3  
Analytical SOP: EMAX-8081 Rev. 7  
Conc Unit: µg/Kg  
Sample Amt(g): 30  
Extract Volume (mL): 10

Instrument ID: E8  
Extraction date: 1/16 & 1/21/14  
Extracted by: J. Villena  
Analysis date: 1/29 & 1/31/14  
Analyzed by: E. Santos

| PARAMETER           | CPA019SL | CPA019SC | CPA033SL | CPA022SC | TV   | Ave. Conc. | Ave. %Rec | SD    | RSD (%) | QC Criteria | COMMENTS |
|---------------------|----------|----------|----------|----------|------|------------|-----------|-------|---------|-------------|----------|
|                     | MA29007A | MA29008A | MA31013A | MA31014A |      |            |           |       |         |             |          |
| Aldrin              | 6.30     | 6.29     | 7.15     | 7.07     | 6.67 | 6.7        | 101       | 0.474 | 7.1     | 60 - 130    | PASSED   |
| alpha-BHC           | 6.21     | 6.20     | 7.26     | 7.29     | 6.67 | 6.7        | 101       | 0.616 | 9.1     | 50 - 140    | PASSED   |
| beta-BHC            | 6.28     | 6.31     | 7.47     | 7.44     | 6.67 | 6.9        | 103       | 0.670 | 9.7     | 60 - 140    | PASSED   |
| delta-BHC           | 6.59     | 6.63     | 7.59     | 7.53     | 6.67 | 7.1        | 106       | 0.546 | 7.7     | 60 - 140    | PASSED   |
| gamma-BHC (Lindane) | 6.29     | 6.27     | 7.08     | 6.96     | 6.67 | 6.6        | 100       | 0.431 | 6.5     | 60 - 130    | PASSED   |
| DDD (4,4)           | 7.53     | 7.63     | 7.47     | 7.42     | 6.67 | 7.5        | 113       | 0.090 | 1.2     | 70 - 140    | PASSED   |
| DDE (4,4)           | 6.67     | 6.75     | 7.47     | 7.39     | 6.67 | 7.1        | 106       | 0.419 | 5.9     | 60 - 140    | PASSED   |
| DDT (4,4)           | 8.07     | 8.16     | 8.82     | 8.89     | 6.67 | 8.5        | 127       | 0.431 | 5.1     | 70 - 150    | PASSED   |
| Dieldrin            | 6.56     | 6.58     | 7.45     | 7.40     | 6.67 | 7.0        | 105       | 0.493 | 7.0     | 60 - 140    | PASSED   |
| Endosulfan I        | 6.14     | 6.12     | 7.23     | 7.11     | 6.67 | 6.6        | 100       | 0.605 | 9.1     | 50 - 130    | PASSED   |
| Endosulfan II       | 6.74     | 7.00     | 7.58     | 7.53     | 6.67 | 7.2        | 108       | 0.410 | 5.7     | 70 - 130    | PASSED   |
| Endosulfan sulfate  | 7.02     | 7.31     | 7.79     | 7.74     | 6.67 | 7.5        | 112       | 0.365 | 4.9     | 60 - 140    | PASSED   |
| Endrin              | 7.16     | 7.29     | 7.43     | 7.34     | 6.67 | 7.3        | 110       | 0.112 | 1.5     | 70 - 140    | PASSED   |
| Endrin Aldehyde     | 6.53     | 6.68     | 7.37     | 7.17     | 6.67 | 6.9        | 104       | 0.396 | 5.7     | 60 - 140    | PASSED   |
| Heptachlor          | 6.19     | 6.28     | 7.08     | 7.14     | 6.67 | 6.7        | 100       | 0.506 | 7.6     | 60 - 130    | PASSED   |
| Heptachlor epoxide  | 6.32     | 6.59     | 7.29     | 7.31     | 6.67 | 6.9        | 103       | 0.502 | 7.3     | 60 - 130    | PASSED   |
| Methoxychlor        | 81.5     | 84.7     | 92.7     | 92.8     | 66.7 | 88         | 132       | 5.686 | 6.5     | 60 - 140    | PASSED   |
| alpha-Chlordane     | 6.59     | 6.60     | 7.33     | 7.28     | 6.67 | 6.9        | 104       | 0.410 | 5.9     | 60 - 130    | PASSED   |
| gamma-Chlordane     | 6.52     | 6.64     | 7.41     | 7.32     | 6.67 | 7.0        | 105       | 0.458 | 6.6     | 60 - 130    | PASSED   |
| Endrin Ketone       | 6.61     | 6.83     | 7.52     | 7.52     | 6.67 | 7.1        | 107       | 0.471 | 6.6     | 70 - 130    | PASSED   |
| Tcx                 | 10.71    | 10.24    | 11.91    | 11.83    | 13.3 | 11.2       | 84        | 0.827 | 7.4     | 50 - 140    | PASSED   |
| DCB                 | 13.1     | 12.7     | 13.9     | 13.7     | 13.3 | 13.4       | 100       | 0.545 | 4.1     | 50 - 140    | PASSED   |









## STANDARD OPERATING PROCEDURES

**POLYCHLORINATED BIPHENYLS (PCB) AND POLYCHLORINATED TERPHENYLS (PCT) BY GAS CHROMATOGRAPHY**

SOP No.: EMAX-8082 Revision No. 5 Effective Date: 02-Jul-14

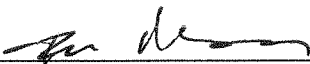
Prepared By: Tu Nisamaneepong  Date: 07-02-14

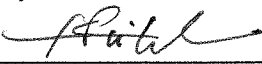
Approved By: Kenette Pimentel   
QA Manager Date: 07-02-14

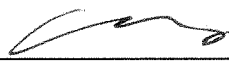
Approved By: Caspar Pang   
Laboratory Director Date: 07-02-14

Control Number: **8082-05-**

**1.0 SCOPE AND APPLICATION**

- 1.1. This procedure is used to determine the concentration of Polychlorinated Biphenyls (PCBs) and Polychlorinated Terphenyls (PCTs) as Aroclors in soil, sediment, sludge, and wastewater samples by gas chromatography method.
- 1.2. This SOP is an adaptation of EPA 8082A. Since EPA 8082A is an update and enhancement of 8082, this SOP is also applicable to EPA 8082.

**2.0 SUMMARY OF METHOD**

- 2.1. This method provides gas chromatographic conditions for the detection of PCB and PCT compounds with dual Electron Capture Detector (ECD). The samples are extracted in methylene chloride, exchanged to hexane and cleaned up by appropriate method before GC analysis.
- 2.2. **Interferences**
  - 2.2.1. Interferences by phthalate esters co-extracted from the sample or introduced during sample preparation can pose a major problem in PCB and PCT determinations. Interferences can be minimized by avoiding contact with any plastic materials and checking all solvents for phthalate contamination. Glassware must be scrupulously cleaned. Sulfuric acid/permanganate cleanup technique can be used for Phthalate esters removal from the extract.
  - 2.2.2. The presence of elemental sulfur will result in broad peaks that may cause chromatographic interfere with the determination of PCBs and PCTs. Sulfur contamination is most likely present in sediment samples. The TBA procedure, GPC or other cleanup technique can be used for sulfur removal from the extract.
  - 2.2.3. Other interferences such as aliphatic compounds, aromatics and nitrogen-containing compounds may be eliminated by using Florisil cleanup.

**3.0 DETECTION LIMITS**

- 3.1. **Detection Limit (DL), Limit of Detection (LOD) & Limit of Quantitation (LOQ)**
  - 3.1.1. Refer to EMAX-QA04 for generation, validation and verification for DL, LOD and LOQ.
  - 3.1.2. Refer to Table 6 for established DL, LOD and LOQ values.

## STANDARD OPERATING PROCEDURES

**POLYCHLORINATED BIPHENYLS (PCB) AND POLYCHLORINATED TERPHENYLS (PCT) BY GAS CHROMATOGRAPHY**SOP No.: EMAX-8082 Revision No. 5 Effective Date: 02-Jul-14**4.0 DYNAMIC RANGE**

- 4.1. The highest quantifiable concentration requiring no dilution is equal to the highest calibration point (see Sec. 9.4). All samples analyzed above this concentration are considered "over-range" and shall require dilution to properly quantitate.
- 4.2. Likewise, the lowest quantifiable concentration of diluted samples is equal to the lowest calibration point. All diluted samples analyzed below this concentration are considered "under-range". A lower dilution factor is required to properly quantitate.
- 4.3. Typical dynamic ranges are:

|                           | PCBs           | PCTs       |
|---------------------------|----------------|------------|
| Water ( $\mu\text{g/L}$ ) | 0.5 - 20.0     | 2.0 - 10.0 |
| Soil ( $\mu\text{g/Kg}$ ) | 16.67 – 666.67 | 40 - 500   |

**5.0 SAMPLE HOLDING TIME & PRESERVATION****5.1. Holding Time**

- 5.1.1. PCBs and PCTs are very stable in a variety of matrices and holding times may be as long as a year.
- 5.1.2. Analysis should be within 40 days after extraction completion date.

**5.2. Preservation**

- 5.2.1. Samples and extract should be kept at  $\leq 6^{\circ}\text{C}$ .

**6.0 ASSOCIATED SOPs**

- 6.1. EMAX-DM01 Data Flow and Review
- 6.2. EMAX-QA014 Detection Limit
- 6.3. EMAX-QA08 Corrective Action
- 6.4. EMAX-QC02 Analytical Standard Preparation
- 6.5. EMAX-SM04 Analytical and QC Labeling
- 6.6. EMAX-3520 Extraction, Continuous Liquid/Liquid
- 6.7. EMAX-3546 Extraction, Microwave
- 6.8. EMAX-3550 Extraction, Pulse Sonication
- 6.9. EMAX-3540 Extraction, Soxhlet
- 6.10. EMAX-3580 Waste Dilution
- 6.11. EMAX-3620 Cleanup, Florisil

## STANDARD OPERATING PROCEDURES

**POLYCHLORINATED BIPHENYLS (PCB) AND POLYCHLORINATED TERPHENYLS (PCT) BY GAS CHROMATOGRAPHY**SOP No.: EMAX-8082 Revision No. 5 Effective Date: 02-Jul-14

- 6.12. EMAX-3660 Cleanup, Sulfur
- 6.13. EMAX-3665 Cleanup, Acid/Permanganate

**7.0 SAFETY**

- 7.1. Read all SDS of chemicals listed in this SOP.
- 7.2. Treat all reagents, standards, and samples as potential hazards. ECD contains minute quantity of Radioactive Ni (63), a wipe test performed by experienced personnel or manufacturer should be conducted semiannually or sooner if potential problem is suspected. Observe standard laboratory safety procedures. Wear protective gear, i.e., lab coat, safety glasses, gloves, at all times when performing this procedure. Perform all sample and standard handling in the fume hood.
- 7.3. If for any reason, solvent and/or other reagents get in contact with your skin or any other part of the body, rinse the affected body part thoroughly with copious amounts of water. If irritations or any other discomfort related to the incident persist, inform your supervisor immediately so that proper action can be taken.

**8.0 INSTRUMENTS, CHEMICALS & REAGENTS****8.1. Instruments and Supplies**

|                    |   |
|--------------------|---|
| Gas Chromatography | HP 5890 Series II   |
| Detector           | Dual Electron Capture Detectors   |
| Column             | RTX CLPESTI (30 m x 0.32 mm x 0.5 µm)<br>RTX CLPESTII (30 m x 0.32 mm x 0.25 µm)<br>(Alternate columns may be used after verification of performance) |
| Data System        | EZ Chrom  |
| Auto Sampler       | HP Model 7673B or equivalent  |
| Gas                | Ultra-high purity hydrogen<br>Ultra-high purity nitrogen  |
| Microsyringes      | 10, 25, 100 and 500 µL with a 0.006 mm ID needle  |
| Volumetric Flasks  | 0,50, and 100 ml with ground glass stopper  |
| Transfer Pipette   | Pasteur   |

**8.2. Chemicals and Reagents**

|                    |  |
|--------------------|--|
| Solvent (GC-grade) | Pesticide-free grade hexane, methylene chloride, isopropanol |
|--------------------|--|

**9.0 STANDARDS****9.1. Preparation**

## STANDARD OPERATING PROCEDURES

**POLYCHLORINATED BIPHENYLS (PCB) AND POLYCHLORINATED TERPHENYLS (PCT) BY GAS CHROMATOGRAPHY**SOP No.: EMAX-8082 Revision No. 5 Effective Date: 02-Jul-14

---

9.1.1. Prepare and label analytical standards according to EMAX-QC02 and EMAX-SM04.

9.2. **Stock Standard**

9.2.1. Purchase Primary Calibration stock standards as certified solutions at 1000 mg/L. After opening, transfer the stock standard to an inert vial and store with a minimum headspace.

9.2.2. Purchase a Secondary set of stock standards from a different source to verify the concentration of the first set of standards. Treat the secondary standards similarly as the primary standards.

9.2.3. Purchase LCS/MS and surrogate standards as certified solutions at 1000 mg/L and 200 mg/L, respectively.

9.2.4. Store all standards at  $\leq 6^{\circ}\text{C}$ , unless otherwise specified.

9.3. **Intermediate Standard**

9.3.1. Prepare intermediate standards (for both primary and secondary) at 4000  $\mu\text{g/L}$  as suggested in Table 1.

9.4. **Initial Calibration Standard (ICAL)**

9.4.1. Prepare a minimum of five calibration standards using primary intermediate standard according to Table 2.

9.5. **Initial Calibration Verification (ICV)**

9.5.1. Prepare ICV using the secondary intermediate standard as described in Table 3.

9.6. **Daily Calibration Check Standard (DCC)**

9.6.1. Prepare DCC using the primary intermediate standard as described in Table 3.

9.7. **Surrogate Standard**

9.7.1. Prepare surrogate standard as described in Table 4.

9.8. **LCS/MS Spike Standard**

9.8.1. Prepare LCS/MS spike standard as described in Table 4.

**10.0 PROCEDURES**

10.1. **Sample Preparation**

10.1.1. Aqueous samples shall be prepared as described in EMAX-3520.

10.1.2. Solid samples shall be prepared as described in EMAX-3550 or EMAX-3546. If necessary, clean up with sulfuric acid as described in EMAX-3665 is performed.

10.2. **Instrument Parameters**

10.2.1. EPA 8082A requires an analytical system complete with a temperature programmable gas chromatograph equipped with an autosampler suitable for on column injection of 1 to 5  $\mu\text{L}$ .

10.2.2. Gas Pressure

## STANDARD OPERATING PROCEDURES

**POLYCHLORINATED BIPHENYLS (PCB) AND POLYCHLORINATED TERPHENYLS (PCT) BY GAS CHROMATOGRAPHY**SOP No.: EMAX-8082 Revision No. 5 Effective Date: 02-Jul-14

Nitrogen Pressure : 40 psi

Hydrogen Pressure : 50 psi

10.2.3. Temperature Program

| <b>RESTEK<br/>RTX CLPest 1 &amp; 2</b> |  |
|--|--|
| Initial Temp                           | 130°C, hold for 0.5 minute   |
| Rate 1                                 | 25°C/min   |
| Temp 1                                 | 230°C, hold for 2 minutes  |
| Rate 2                                 | 5°C/min  |
| Temp 2                                 | 260°C, hold for 0.2 minute   |
| Rate 3                                 | 25°C/min   |
| Final Temp                             | 290°C, hold for 1 minute (PCB)<br>290°C, hold for 17 mins. (PCB+PCT) |
| Injector                               | 230°C  |
| Detector                               | 300°C  |
| Injection Volume                       | 1 µL   |

10.3. **Calibration**10.3.1. Initial Calibration (ICAL)

- 10.3.1.1. A standard containing a mixture of Aroclor 1016 and Aroclor 1260 will include many of the peaks represented in other five Aroclor mixtures. As a result, a multi-point initial calibration employing a mixture of Aroclor 1016 and 1260 at a minimum of five concentrations should be sufficient to demonstrate the linearity of the detector response without the necessity of performing initial calibration for each of the seven Aroclors.
- 10.3.1.2. A separate set of calibration standards containing Aroclor 5460 is also prepared.
- 10.3.1.3. Initial calibration standards (or as suggested in Table 2) of Aroclors 1016, 1260, and 5460 are analyzed by direct injection.
- 10.3.1.4. Three to five characteristic peaks from each Aroclor are chosen for quantitation. Peaks should be at least 25% of the height of the largest Aroclor peak. Tabulate each peak area response against concentration of injected standard. Calculate each calibration factor according to Eq. 10.6.1.1. A minimum of five sets of calibration factors will be generated for each Aroclor.
- 10.3.1.5. Application of ICAL Curve for Quantitation
- 10.3.1.5.1. Generate a summary of calibration factors for each analyte at each concentration using Eq-10.6.1. Calculate the Average Calibration

## STANDARD OPERATING PROCEDURES

**POLYCHLORINATED BIPHENYLS (PCB) AND POLYCHLORINATED TERPHENYLS (PCT) BY GAS CHROMATOGRAPHY**SOP No.: EMAX-8082 Revision No. 5 Effective Date: 02-Jul-14

Factor (ACF), the Standard Deviation (SD), and the Relative Standard Deviation (RSD) according to, Eq. 10.6.2, Eq. 10.6.3 and Eq. 10.6.4, respectively.

- If RSD is  $\leq 20\%$ , ACF may be applied.
- Apply Inverse Weighting Factor ( $1/y$  or  $1/y^2$ ;  $y$  being the instrument response) if it is determined to be the best fit for specific analytes. This approach may be applied to any analyte including analyte that has RSD of  $\leq 20\%$  and correlation coefficient of  $\geq 0.995$ .
- Apply linear least squares regression if past experience or priori knowledge of instrument response is known to be the best fit for specific analytes. This approach may be applied to any analyte including analyte that has RSD of  $\leq 20\%$  and correlation coefficient of  $\geq 0.995$ .
- It may be appropriate to force the regression through zero for specific analytes<sup>1</sup>. When exercising this option [as included in the data acquisition software], make sure that the origin (0,0) is not included as a calibration point but rather the intercept is set to zero. This option shall only be applied if the curve favors better accuracy of quantitation.

10.3.1.6. In situations where a particular Aroclor is of interest for a specific project, a minimum five-point calibration curve of that Aroclor may be employed.

10.3.1.7. Submit summary of ICAL, raw data and manual integration (if any) for secondary review.

10.3.1.8. Refer to Appendix 1 for acceptance criteria. If acceptance criteria are not met refer to Section 12 for corrective action.

10.3.2. Initial Calibration Verification (ICV)

10.3.2.1. Prepare a mid-level calibration standard of Aroclors 1260 + 1016 and Aroclor 5460 from a second source. Analyze these after the initial calibration to verify the ICAL.

10.3.2.2. Calculate the %Difference (%D) using Eq. 10.6.2.1. This should be equal to or less than 20%.

10.3.2.3. The standards of the other Aroclors are used to determine a single-point calibration factor for each Aroclor and pattern recognition. It can be analyzed before or after the Aroclor 1016/1260 and 5460 standards.

10.3.3. Daily Calibration Check (DCC)

<sup>1</sup> SW846 Method 8000B, Section 7.5.3; SW846 Method 8000C, Section 11.5.2.1

## STANDARD OPERATING PROCEDURES

**POLYCHLORINATED BIPHENYLS (PCB) AND POLYCHLORINATED TERPHENYLS (PCT) BY GAS CHROMATOGRAPHY**SOP No.: EMAX-8082 Revision No. 5 Effective Date: 02-Jul-14

---

- 10.3.3.1. For daily run, analyze DCC (mid-level Aroclor 1016 + 1260 and 5460 standards) at the start of the 12-hour shift prior to sample analysis, and close the analytical run with an ending DCC. A 12-hour shift interval must not exceed 20 samples.
- 10.3.3.2. The calibration check process does not require analysis of the other Aroclor standards used for pattern recognition.
- 10.3.3.3. Calculate the %D by using Eq. 10.6.2.1. Refer to Appendix 1 for acceptance criteria.
- 10.3.3.4. For projects wherein specific PCB is expected to be found, analyze DCC of that particular PCB at 500 µg/L.

**10.4. Analysis****10.4.1. Analytical Sequence**

10.4.1.1. Following the instrument data acquisition software, prepare the analytical sequence file as suggested below:

- Instrument Blank
- Minimum Five Calibration Standards of Aroclors 1016/1260
- Minimum Five Calibration Standards of Aroclor 5460
- Calibration Standards of Aroclor 1254, 1248, 1242, 1232, 1221, 1262, 5432 and 5442 (as necessary) \*
- Initial Calibration Verification of Aroclor 1016/1260 and Aroclor 5460
- Method Blank
- Lab Control Sample
- Samples (up to 12 hours but not more than 20 samples)
- Continuing Calibration Standard of of Aroclor 1016/1260 and Aroclor 5460 or other calibrated Aroclors

**10.4.2. Sample Analysis**

- 10.4.2.1. Transfer a minimum of 0.5 mL of extract to a 2-mL autosampler vial (or equivalent) using a Pasteur pipette. Cap the vial with a teflon septum and seal with an aluminum rim.
- 10.4.2.2. Introduce extract into the gas chromatograph using direct injection technique (1 to 5 µl) after all quality control criteria have been met.
- 10.4.2.3. If the response exceeds the linear range of the system, dilute the sample and re-analyze.

**10.4.3. Sample Result Evaluation**

---

\* Include Calibration standards for Aroclor 1254, 1248, 1242, 1232, 1221, 1262, 1268, 5432 and 5442 if pattern is found in the sample.

## STANDARD OPERATING PROCEDURES

**POLYCHLORINATED BIPHENYLS (PCB) AND POLYCHLORINATED TERPHENYLS (PCT) BY GAS CHROMATOGRAPHY**SOP No.: EMAX-8082 Revision No. 5 Effective Date: 02-Jul-14

- 10.4.3.1. Check QC parameters as soon as the data is available.
- ✓ Check LCS recovery that it is within QC limits (Appendix 1).
  - ✓ Check MB that is project compliant.
  - ✓ Check retention time.
  - ✓ Check surrogate recoveries against Appendix 1.
  - ✓ Check concentration of target analytes. If the response exceeds the calibration range, dilute and re-analyze the sample until the response falls within the calibration range.
  - ✓ If any of the above checkpoints indicate a problem, re-analysis is required. If re-analysis results are the same as the initial result, consult the Supervisor for further action. If results indicate extraction problem, order re-extraction for the affected sample(s).
- 10.4.3.2. Identification of a multicomponent analyte in the sample is based on pattern recognition in conjunction with the elution of three to five peaks on both GC columns.
- 10.4.3.3. Positive identification is made when a target peak falls within the retention time window on both columns established by the standard reference compound.
- 10.4.3.3.1. If one column meets the retention time criteria and a retention time shift is suspected on the other column, use the following guideline in reporting the data:
- ✓ Check that the expanded window does not exceed the RTW of the column in control or the established RTW or the CLP RTW<sup>2</sup> whichever is greater.
  - ✓ If the above condition is met, report the data and include a description of the observation in the case narrative.
- 10.4.3.4. The agreement between the quantitative results should be evaluated after the identification is made. Calculate the relative percent difference (RPD) between the two results according to Eq. - 10.6.4.2.
- If the RPD is less than 40% and the pattern peaks do not indicate any anomalies, report the higher result.
  - If the RPD is less than 40% and the pattern peaks indicate an anomaly, report the result from the better pattern peaks.
  - If the RPD is greater than 40%, use professional judgment. If no anomaly is found, report the higher result.

10.4.4. Retention Time Window10.4.4.1. **Establishing RTW**<sup>2</sup> CLP-OLM4.2 Table 1 D-79/PEST



## STANDARD OPERATING PROCEDURES

**POLYCHLORINATED BIPHENYLS (PCB) AND POLYCHLORINATED TERPHENYLS (PCT) BY GAS CHROMATOGRAPHY**SOP No.: EMAX-8082 Revision No. 5 Effective Date: 02-Jul-14

---

- 10.4.4.1.1. Collect at least three Daily Calibration Standards analyzed over a period of 72 hours.
- 10.4.4.1.2. Calculate the Standard Deviation (SD) of absolute retention time obtained for each of the major peaks used for calibration.
- 10.4.4.1.3. Determine the width of RTW by  $\pm 3X$  SD.
- 10.4.4.2. **Evaluating RTW**
- 10.4.4.2.1. If the SD is equal to 0.00, default to the previous study until historical data is obtained.
- 10.4.4.2.2. For new instruments, in the interim use the CLP retention time window for Aroclors ( $\pm 0.07$  min) until RTW is obtained for the new instrument parameters condition.
- 10.4.4.3. **Application of RTW**
- 10.4.4.3.1. Establish the center of absolute retention time for each of the characteristic peak to include the surrogate(s) from the daily calibration check at the beginning of the analytical shift then apply the established RTW.
- 10.4.4.3.2. Whenever the observe retention time is outside the established RTW, the analyst is advised to determine the cause and perform necessary corrective action before continuing analyses.
- 10.4.4.4. **Updating RTW**
- 10.4.4.4.1. Re-establish the RTW as described in Section 10.4.4.1 when any of the following conditions occur:
- Yearly RTW update
  - Significant shifting is observed (e.g. succeeding calibration checks or LCS are out of RTW)
  - Major instrument maintenance (e.g. replacements of detector or column; temperature program change, etc.)
- 10.4.5. Manual Integration
- 10.4.5.1. Refer to EMAX-DM01 for details of manual integration.
- 10.4.6. Dealing with Carryover
- 10.4.6.1. Check the sample analyzed after a sample having target analyte concentrations exceeding the calibration range.
- 10.4.6.2. If there was no target analyte detected (as found in the sample that exceeded calibration range), proceed with data reduction.
- 10.4.6.3. If there was a target analyte detected (as found in the sample that exceeded the calibration range), re-analyze the sample to rule-out carry-over. If carry-over is confirmed, proceed with data reduction and report the data from the re-analyzis.

## STANDARD OPERATING PROCEDURES

**POLYCHLORINATED BIPHENYLS (PCB) AND POLYCHLORINATED TERPHENYLS (PCT) BY GAS CHROMATOGRAPHY**SOP No.: EMAX-8082 Revision No. 5 Effective Date: 02-Jul-14**10.5. Data Reduction**

- 10.5.1. Make a copy of the analytical run log and highlight the data to be reported.
- 10.5.2. Collate the reportable raw data. Segregate raw data for samples, QC data and calibration data using section dividers.
- 10.5.3. Keep all other unused data generated during the analysis in the analytical folder and mark with "For record only".
- 10.5.4. Proceed to report generation.

**10.6. Calculations****10.6.1. Initial Calibration****10.6.1.1. Calculate for Calibration Factor (CF)**

$$CF = \frac{R_a}{C_a} \quad \text{Eq.-10.6.1.1}$$

*where:*

- $R_a$  - response for analyte measured in peak area
- $C_a$  - Concentration of analyte ( $\mu\text{g/L}$ )  $\times 1/N$
- $N$  - number of identification peak in each Aroclor

**10.6.1.2. Calculate for Average Calibration Factor (ACF)**

$$ACF = \frac{\sum CF_a}{n} \quad \text{Eq.-10.6.1.2}$$

*where:*

- ACF - average calibration factor
- $\sum CF_a$  - sum of calibration factors
- $n$  - number of calibration points

**10.6.1.3. Calculate for Standard Deviation**

$$SD = \sqrt{\frac{\sum_{i=1}^N (x_i - \bar{x})^2}{N - 1}} \quad \text{Eq.-10.6.1.3}$$

*where:*

- SD - standard deviation
- $x_i$  - result at  $i^{\text{th}}$  measurement
- $\bar{x}$  - mean of all  $x$  measurements

## STANDARD OPERATING PROCEDURES

**POLYCHLORINATED BIPHENYLS (PCB) AND POLYCHLORINATED TERPHENYLS (PCT) BY GAS CHROMATOGRAPHY**SOP No.: EMAX-8082 Revision No. 5 Effective Date: 02-Jul-14

N - number of measurements

**10.6.1.4. Calculate for % Relative Standard Deviation (%RSD)**

$$\%RSD = \frac{SD}{ACF} * 100\% \quad \text{Eq.-10.6.1.4}$$

where:

RSD - relative standard deviation

SD - standard deviation

ACF - average calibration factor

**10.6.1.5. Calculate for Least Square Line Regression**

$$y = ax + b \quad \text{Eq.-10.6.1.5}$$

where:

y – Response Factor

x – Concentration

a = x1 = slope of the line

$$a = \frac{\sum(x - \bar{x})(y - \bar{y})}{(x - \bar{x})^2}$$

 $\bar{x}$  - Average of amount ratios $\bar{y}$  - Average of response ratios

b = x0 = intercept of the line

$$b = \bar{y} - a * \bar{x}$$

**10.6.1.6. Calculate for Inverse Weighting Factor**

$$y = ax + b \quad \text{Eq.-10.6.1.6}$$

where:

y – Response Factor

x – Concentration

a – x1 = slope of the line

$$a = \frac{\sum[(x - x_a)(y - y_a)]}{\sum(x - x_a)^2}$$

where:

## STANDARD OPERATING PROCEDURES

**POLYCHLORINATED BIPHENYLS (PCB) AND POLYCHLORINATED TERPHENYLS (PCT) BY GAS CHROMATOGRAPHY**SOP No.: EMAX-8082 Revision No. 5 Effective Date: 02-Jul-14

$$x_a = \Sigma [x(1/x) / \Sigma(1/x)]$$

$$y_a = \Sigma [y(1/x) / \Sigma(1/x)]$$

$$x_a = \Sigma [x(1/x^2) / \Sigma(1/x^2)]$$

$$y_a = \Sigma [y(1/x^2) / \Sigma(1/x^2)]$$

$b = x_0 =$  intercept of the line

$$b = y_a - a * x_a$$

10.6.2. Calibration Check/Continuing Calibration10.6.2.1. **Calculate Percent Difference**

$$\% D = \frac{ACF - CF}{ACF} * 100\% \quad \text{Eq.-10.6.2.1}$$

where:

ACF - average calibration factor

CF - calibration factor at calibration check standard

10.6.3. Sample Results

10.6.3.1. Identify 3 to 5 major peaks as quantitative peaks for each Aroclor. Establish the ACF of each peak as outlined in Section 10.6.1.1. Calculate the concentration of each peak in Aroclor according to Eq. - 10.6.3.2 or Eq. - 10.6.3.3. The concentration of Aroclor equals the sum of the concentrations of these major peaks according to Eq. - 10.6.3.4.

10.6.3.2. **Water Samples**

$$C_n = \left( \frac{R_a}{ACF} \right) \left( \frac{V_e}{S_a} \right) DF \quad \text{Eq-10.6.3.2}$$

where:

$C_n$  - Concentration of characteristic peak n measured ( $\mu\text{g/L}$ )

$R_a$  - Total response of analyte in peak area

ACF - Average calibration factor

$V_e$  - Volume of extract in ml

$S_a$  - Sample amount in ml

DF - Dilution factor of sample extract

10.6.3.3. **Soil Samples**

## STANDARD OPERATING PROCEDURES

**POLYCHLORINATED BIPHENYLS (PCB) AND POLYCHLORINATED TERPHENYLS (PCT) BY GAS CHROMATOGRAPHY**SOP No.: EMAX-8082 Revision No. 5 Effective Date: 02-Jul-14

$$C_n = \left( \frac{R_a}{ACF} \right) \left( \frac{V_e}{S_a (\% \text{ Solid})} \right) DF \quad \text{Eq.10.6.3.3}$$

where

- $C_n$  - Concentration of characteristic peak n measured ( $\mu\text{g}/\text{kg}$ )  
 $R_a$  - Total response of analyte in peak area  
ACF - Average calibration factor  
 $V_e$  - Volume of extract in ml  
 $S_a$  - Sample Amount in g  
% Solid -  $\frac{100 - \% \text{ moisture}}{100}$   
DF - Dilution factor of the sample extract

10.6.3.4. **Final Aroclor Concentration**

$$C = C_1 + C_2 + \dots + C_n \quad \text{Eq.-10.6.3.4}$$

where:

- $C$  - Concentration of Aroclor in sample ( $\mu\text{g}/\text{L}$  or  $\mu\text{g}/\text{kg}$ )  
 $C_1$  - Concentration of characteristic peak 1  
 $C_2$  - Concentration of characteristic peak 2  
n - Characteristic peak number in each Aroclor

10.6.4. **Accuracy and Precision**10.6.4.1. **Percent Recovery**

$$\% R = \frac{C_f - C}{C_s} * 100 \quad \text{Eq.-10.6.4.1}$$

where:

- %R - percent recovery  
 $C_f$  - concentration of spiked sample  
 $C_s$  - concentration of spike  
C - concentration of unspiked sample (For LCS recovery, C=0)

10.6.4.2. **Relative Percent Difference**

$$\% RPD = \frac{|C_1 - C_2|}{\left( \frac{C_1 + C_2}{2} \right)} \times 100 \quad \text{Eq.-10.6.4.2}$$

## STANDARD OPERATING PROCEDURES

**POLYCHLORINATED BIPHENYLS (PCB) AND POLYCHLORINATED TERPHENYLS (PCT) BY GAS CHROMATOGRAPHY**SOP No.: EMAX-8082 Revision No. 5 Effective Date: 02-Jul-14

---

where:

- %RPD - Relative Percent Difference
- C<sub>1</sub> - Measured concentration of the first sample aliquot
- C<sub>2</sub> - Measured concentration of the second sample aliquot

**10.7. Report Generation**

- 10.7.1. Generate the method.txt file using WDB1C .exe
- 10.7.2. Generate Lab Chronicle using LABCHRN1.exe
- 10.7.3. Generate sample results using F1NV3C .exe
- 10.7.4. Generate the QC Summary file using QCV3CN .exe
- 10.7.5. Generate the case narrative using CN1.exe.
- 10.7.6. Arrange the analysis package in sequence as detailed below using section separators. Attach all raw data to every form generated, to include manual integration(s) and re-analysis.
  - 10.7.6.1. Case Narrative
  - 10.7.6.2. Lab Chronicle
  - 10.7.6.3. Sample Results
  - 10.7.6.4. LCS Summary
  - 10.7.6.5. MS/MSD Summary
  - 10.7.6.6. ICAL Summary
  - 10.7.6.7. ICV Summary
  - 10.7.6.8. DCC Summary
  - 10.7.6.9. Analytical Run Log
  - 10.7.6.10. Sample Preparation Log
  - 10.7.6.11. Non-Conformance Report (if any)

**10.8. Data Review**

- 10.8.1. Perform a 100% data review in accordance to EMAX-DM01 and the project specific requirements (PSR).
  - 10.8.1.1. If any of the checkpoints below indicate a problem, re-analysis is required.
    - ✓ Check that all samples required for analysis are analyzed.
    - ✓ Check that samples are extracted and analyzed within holding time.
    - ✓ Check that all calibration requirements are fulfilled.
    - ✓ Check the chromatogram of all positively identified Aroclor patterns that they are qualitatively identified and qualitatively accurate.
    - ✓ Check surrogate recoveries against required limits.

## STANDARD OPERATING PROCEDURES

**POLYCHLORINATED BIPHENYLS (PCB) AND POLYCHLORINATED TERPHENYLS (PCT) BY GAS CHROMATOGRAPHY**SOP No.: EMAX-8082 Revision No. 5 Effective Date: 02-Jul-14

✓ Check that concentration of target analytes are within calibration range.

10.8.2. Review the case narrative and check that it accurately describes what transpired in the analytical process. Edit as necessary to reflect essential issues not captured by the case narrative generator program.

10.8.3. Submit the analysis package for secondary review.

10.9. **Preventive Maintenance**

10.9.1. Refer to Form 8082FM for daily routine maintenance check points.

10.9.2. Record instrument maintenance performed in the instrument maintenance log. Initial the column corresponding to the date when the instrument was back in control.

10.9.3. Instruments should receive routine preventive maintenance and recorded in instrument-specific maintenance logs. Routine maintenance ensures that all equipment is operating under optimum conditions, thus reducing the possibility of instrument malfunction and consequently affecting data quality. The table below is a list of preventive maintenance activities that are essential to consider in performing this SOP.

| <b>Maintenance Activity</b> | <b>Description</b>   | <b>Frequency</b>               |
|-----------------------------|--|--------------------------------|
| Autosampler Check           | Inspect and clean syringe. Check autosampler response.   | Daily prior to analysis        |
| Verification                | Check instrument parameters to ensure normal operating conditions.<br>Check liner as necessary.<br>Check instrument performance (e.g., daily calibration check, instrument blank, DDT/Endrin breakdown). | Daily prior to analysis        |
| Documentation               | Record maintenance in instrument service logs.   | Daily prior to analysis        |
| Leak Test                   | Perform inlet pressure decay test.   | Every 6 months or as necessary |
| System Cleaning             | Remove dust from fans and vent covers, inspect and clean inlet and detector where applicable.  | Every 6 months or as necessary |
| Check Flow Path Components  | Check and replace the following as necessary: tubing assembly, union, sample probe, and loop.  | Once a year or as necessary    |
| Complete Inspection         | Perform general inspection of the complete system.<br>Inspect autosampler cabling and configuration setting.   | Once a year                    |

## STANDARD OPERATING PROCEDURES

**POLYCHLORINATED BIPHENYLS (PCB) AND POLYCHLORINATED TERPHENYLS (PCT) BY GAS CHROMATOGRAPHY**SOP No.: EMAX-8082 Revision No. 5 Effective Date: 02-Jul-14

---

**11.0 QUALITY CONTROL****11.1. Preparative Batch**

- 11.1.1. A preparative batch shall consist of a method blank, LCS, MS/MSD and a maximum of 20 field samples of similar matrix.
- 11.1.2. In the absence of MS/MSD, LCS/LCD is prepared.
- 11.1.3. Surrogate standard shall be added to all samples, including method blank LCS/LCD and MS/MSD. Check PSR for QC Control Limits.
- 11.1.4. Perform QC check prior to utilizing the surrogate and LCS/MS spike standards by analyzing the prepared standard at the spiking level. Results should be within  $\pm 20\%$  of the expected value.

**11.2. Analytical Batch QC**

- 11.2.1. Instrument Blank must be analyzed daily to establish zero baseline or background value.
- 11.2.2. A continuing calibration shall be performed before any other analysis is done. The continuing calibration procedure and the acceptance criteria are discussed in Section 10.3.2 and Appendix 1.

**11.3. Method QC**

- 11.3.1. Analyst demonstration of proficiency is a must prior to performing this analysis.
- 11.3.2. A valid LOD and LOQ must exist prior to sample analysis.
- 11.3.3. A valid ICAL must exist prior to sample analysis.
- 11.3.4. Instrument performance must be checked prior to sample analysis. Check Appendix 1 for acceptance criteria.
- 11.3.5. Prepare and analyze QC samples, to include, method blank, LCS (LCD), and MS/MSD. QC Control Limits shall follow the Project Specific Requirement (PSR) in each analytical folder.

**12.0 CORRECTIVE ACTION**

- 12.1. Corrective actions associated with this analytical procedure are described in the Summary of Quality Control Procedures in Appendix 1. Document out-of-control event and corrective action in the analytical logbook. If the problem persists, consult the supervisor.
- 12.2. If Initial calibration is non-compliant, consider the following suggestions to correct the problem:
  - 12.2.1. If %RSD is out of acceptance criteria, review result and identify presence of an outlier.
  - 12.2.2. If one of the standard returns a bias-low or bias-high on all of the analytes, then that point is considered an outlier, prepare a standard at that ICAL point and reanalyze.
  - 12.2.3. If the highest ICAL point appears to be saturated, drop the highest point.
  - 12.2.4. If the lowest point returns a bias-low response or the peaks are not distinct and sharp, consider the point not usable.

*Note: The lowest calibration point identifies the limit of quantitation (LOQ). Therefore, check that the LOQ is in conformance to the current projects to which the ICAL will be used.*



## STANDARD OPERATING PROCEDURES

**POLYCHLORINATED BIPHENYLS (PCB) AND POLYCHLORINATED TERPHENYLS (PCT) BY GAS CHROMATOGRAPHY**SOP No.: EMAX-8082 Revision No. 5 Effective Date: 02-Jul-14

---

- 12.2.5. If instrumentation problem is suspected, consider the following suggestions to correct the problem:
  - 12.2.5.1. Check the connections and make sure they are air-tight and perform maintenance as needed.
  - 12.2.5.2. Check the gas flow
  - 12.2.5.3. Prepare a fresh standard and repeat calibration
- 12.2.6. If the problem persists, inform the supervisor.
- 12.3. If the ICV is non-compliant, consider the following suggestions to correct the problem:
  - 12.3.1. Re-analyze ICV ( to rule out poor injection)
  - 12.3.2. If ICV is still out of acceptance criteria, prepare a fresh standard and re-analyze to rule out any preparation error
  - 12.3.3. If ICV is still out of acceptance criteria, prepare a fresh ICAL standard and repeat calibration
  - 12.3.4. If the problem persists, inform the supervisor
- 12.4. If the instrument blank is non-compliant, consider the following suggestions to correct problem:
  - 12.4.1. Rule out instrument contamination by performing the instrument daily maintenance, such as changing septum, cleaning liner, cleaning or using new auto sampler syringe.
  - 12.4.2. Rule out reagent contamination by testing solvent used for analysis and working internal standard.
  - 12.4.3. Rule out preparation contamination by preparing a new instrument blank
  - 12.4.4. If the problem persists, inform the supervisor.
- 12.5. If Continuing Calibration is non-compliant, consider the following suggestions to correct the problem:
  - 12.5.1. Change the liner
  - 12.5.2. Clean injection port
  - 12.5.3. Prepare new standard
  - 12.5.4. Cut or replace column
  - 12.5.5. Clean the detector
  - 12.5.6. Rule out leaks by checking all connections
  - 12.5.7. If continuing calibration is still non-compliant, prepare a new standard and repeat the ICAL
- 12.6. If Method Blank is non-compliant, consider the following suggestions to correct the problem:
  - 12.6.1. Rule out instrument contamination by checking instrument blank
  - 12.6.2. Rule out reagent contamination by testing each reagent used for extraction as described in EMAX-QC01
  - 12.6.3. Rule out glassware contamination used for extraction as described in EMAX-QC07
  - 12.6.4. Re-extract MB and the associated samples with reagents free of contamination or with newly

## STANDARD OPERATING PROCEDURES

**POLYCHLORINATED BIPHENYLS (PCB) AND POLYCHLORINATED TERPHENYLS (PCT) BY GAS CHROMATOGRAPHY**SOP No.: EMAX-8082 Revision No. 5 Effective Date: 02-Jul-14

---

opened reagents

12.6.5. If the problem persists, inform the supervisor

12.7. If LCS is non-compliant, perform the following suggestions to correct the problem:

12.7.1. If result is bias-high or bias-low, check the LCS Standard by analyzing at the spike level

12.7.2. If LCS check is within 80-120% of expected value, check calibration of the micropipette or syringe used for spiking. Re-extract and re-analyze the LCS and the associated samples.

12.7.3. If LCS check is not within 80-120% of expected value, prepare a fresh LCS Standard, re-extract and re-analyze LCS and the associated samples.

12.8. Initiate a Non-Conformance Report (NCR) when the following circumstances occur:

- Anomalies other than specified in Appendix 1 is observed.
- Sample is out of technical holding time.

12.8.1. Refer to EMAX-QA08 for NCR details.

12.9. For other problems encountered, inform the supervisor immediately for further instructions.

**13.0 POLLUTION PREVENTION**

13.1. Observe all necessary precautions to avoid spillage of solvent that may go to wastewater drains.

13.2. Prepare all standard s in fume hoods.

**14.0 WASTE MANAGEMENT**

14.1. No samples shall be dumped on the laboratory sink.

14.2. Separate and properly identify all unused and expired analytical standards for proper disposal.

14.3. Place all waste generated during analytical process in properly labeled satellite waste containers for proper collection.

14.4. Dispose all unused samples, expired analytical standards and other waste generated during the analytical process in accordance to EMAX-SM03.

**15.0 SUPPLEMENTARY NOTES****15.1. Definition of Terms**

15.1.1. Analyte – The specific chemicals or components for which a sample is analyzed; may be a group of chemicals that belong to the same chemical family, and which are analyzed together.

15.1.2. Batch – is a group of samples that are prepared and/or analyzed at the same time using the same lot of reagents.

15.1.2.1. **Preparation Batch** – is composed of one to 20 samples of the same matrix, a method blank, a lab control sample and matrix spike/matrix spike duplicate.

## STANDARD OPERATING PROCEDURES

**POLYCHLORINATED BIPHENYLS (PCB) AND POLYCHLORINATED TERPHENYLS (PCT) BY GAS CHROMATOGRAPHY**SOP No.: EMAX-8082 Revision No. 5 Effective Date: 02-Jul-14

---

- 15.1.2.2. **Analytical Batch** – is composed of prepared samples (extracts, digestates, or concentrates), which are analyzed together as a group using an instrument in conformance to the analytical requirement. An analytical batch can include samples originating from various matrices, preparation batches, and can exceed 20 samples.
- 15.1.3. **Detection Limit (DL)** – is defined as the smallest analyte concentration that can be demonstrated to be different from zero or a blank concentration at the 99% level of confidence. At the DL, the false positive rate (Type I error) is 1%.
- 15.1.4. **Limit of Detection (LOD)** – is defined as the smallest amount or concentration of a substance that must be present in a sample in order to be detected at a high level of confidence (99%). At the LOD, the false negative result rate (Type II error) is 1%.
- 15.1.5. **Limit of Quantitation (LOQ)** – is at the lowest concentration that produces a quantitative result within specified limits of precision and bias. For DoD projects, the LOQ shall be set at or above the concentration of the lowest initial calibration standard.
- 15.1.6. **Safety Data Sheet (SDS)** – is written information concerning a chemical physical properties, toxicity, health hazards, fire hazard and reactivity data including storage, spill and handling precautions.
- 15.1.7. **Calibration** – is a determinant measured from a standard to obtain the correct value of an instrument output.
- 15.1.8. **Calibration Blank** – is a target-analyte-free solvent subjected to the entire analytical process to establish zero baseline or background value.
- 15.1.9. **Characteristic Peaks** – are major identifying and quantifying peaks for each type of Aroclor.
- 15.1.10. **Instrument Method** – is a file generated to contain the instrument calibration and instrument parameter settings for a particular analysis.
- 15.1.11. **Method Blank** – is a target-analyte-free sample subjected to the entire sample preparation and/or analytical to monitor contamination.
- 15.1.12. **Lab Control Sample (LCS)** – is a target-analyte-free sample spiked with a verified known amount of target analyte(s) or a reference material with a certified known value subjected to the entire sample preparation and/or analytical process. LCS is analyzed to monitor the accuracy of the analytical system.
- 15.1.13. **Lab Control Sample Duplicate (LCSD)** – is a replicate of LCS analyzed to monitor precision in the absence of MS/MSD sample.
- 15.1.14. **Sample** – is a specimen received in the laboratory bearing a sample label traceable to the accompanying COC. Samples collected in different containers having the same field sample ID are considered the same and therefore labeled with the same lab sample ID unless otherwise specified by the project.
- 15.1.15. **Sample Duplicate** – is a replicate of a sub-sample taken from one sample, prepared and analyzed within the same preparation batch.
- 15.1.16. **Sub-sample** – is an aliquot taken from a sample for analysis. Each sub-sample is uniquely identified by the sample preparation ID.

## STANDARD OPERATING PROCEDURES

**POLYCHLORINATED BIPHENYLS (PCB) AND POLYCHLORINATED TERPHENYLS (PCT) BY GAS CHROMATOGRAPHY**SOP No.: EMAX-8082 Revision No. 5 Effective Date: 02-Jul-14

- 15.1.17. Matrix – is a component or form of a sample.
- 15.1.18. Matrix Spike (MS) – is a sample spiked with a verified known amount of target analyte(s) subjected to the entire sample preparation and/or analytical process. MS is analyzed to monitor matrix effect on a method's recovery efficiency.
- 15.1.19. Matrix Spike Duplicate (MSD) – is a replicate of MS analyzed to monitor precision or recovery.
- 15.1.20. Surrogate – are compounds added to every blank, sample, matrix spike, matrix spike duplicate and standard; used to evaluate analytical efficiency by measuring recovery. Compounds not expected to be detected in environmental media.
- 15.1.21. Reagent Water – is purified water free from any target analyte or any other substance that may interfere with the analytical process.
- 15.1.22. Reagent Soil – organic-free Ottawa sand or equivalent.

**15.2. Application of QC Procedures**

- 15.2.1. The procedures and QC criteria summarized in this SOP applies to all projects when performing PCB analysis by GC/MS. In instances where there is a project or program QAPP, the requirements given in the project takes precedence over this SOP.

**15.3. Department of Defense (DoD) and Department of Energy (DoE) Projects**

- 15.3.1. Samples from DoD and DoE sponsored projects shall follow the Quality Assurance Project Plan (QAPP), Statement of Work (SOW) and/or client's quality control directive. In the absence of QAPP, the DoD Quality Systems Manual (QSM), latest update, shall be applied.

**16.0 REFERENCES**

- 16.1. "Test Methods for Evaluating Solid Waste, Physical and Chemical Methods" (SW846) Method 8082A Rev. 1, Feb. 2007 and Method 8082 Rev. 0, Dec. 1996
- 16.2. "Test Methods for Evaluating Solid Waste, Physical and Chemical Methods" (SW846) Method 8000B, Rev. 2 Dec. 1996 and Method 8000C Rev. 3, March 2003
- 16.3. EMAX Quality Systems Manual, as updated

**17.0 APPENDICES****17.1. Figures**

- |         |           |                                     |
|---------|-----------|-------------------------------------|
| 17.1.1. | Figure 1  | Peak Evaluation Technique           |
| 17.1.2. | Figure 2A | Typical PCB Patterns                |
| 17.1.3. | Figure 2B | Typical PCT Patterns                |
| 17.1.4. | Figure 3A | Typical 1016/1260 Chromatogram      |
| 17.1.5. | Figure 3B | Typical 5460 Chromatogram           |
| 17.1.6. | Figure 4  | Typical Initial Calibration Summary |

## STANDARD OPERATING PROCEDURES

**POLYCHLORINATED BIPHENYLS (PCB) AND POLYCHLORINATED TERPHENYLS (PCT) BY GAS CHROMATOGRAPHY**SOP No.: EMAX-8082 Revision No. 5 Effective Date: 02-Jul-14

---

|          |                   |  |
|----------|-------------------|--|
| 17.1.7.  | Figure 5          | Typical Retention Time Window Summary                                |
| 17.1.8.  | Figure 6          | Typical Sample Result Summary  |
| 17.1.9.  | Figure 7          | Typical LCS/LCSD Summary   |
| 17.1.10. | Figure 8          | Typical MS/MSD Summary   |
| 17.1.11. | Figure 9          | Typical Case Narrative   |
| 17.2.    | <b>Tables</b>     |  |
| 17.2.1.  | Table 1           | Intermediate Standard Preparation                                    |
| 17.2.2.  | Table 2           | Initial Calibration Standard Preparation                             |
| 17.2.3.  | Table 3           | Calibration Check Standard Preparation                               |
| 17.2.4.  | Table 4           | Spike Standard and Surrogate Standard Preparation                    |
| 17.2.5.  | Table 5           | Compound List  |
| 17.2.6.  | Table 6           | Established Limit of Detection (LOD) and Limit of Quantitation (LOQ) |
| 17.3.    | <b>Appendices</b> |  |
| 17.3.1.  | Appendix 1        | Summary of Quality Control Procedures                                |
| 17.3.2.  | Appendix 2        | Demonstration of Capability  |
| 17.4.    | <b>Forms</b>      |  |
| 17.4.1.  | 8082FPA           | Sample Preparation Log   |
| 17.4.2.  | 8082FP            | Analytical Run Log   |
| 17.4.3.  | 8082FM            | Instrument Maintenance Log   |

**Figure 1: PEAK EVALUATION TECHNIQUE**

---

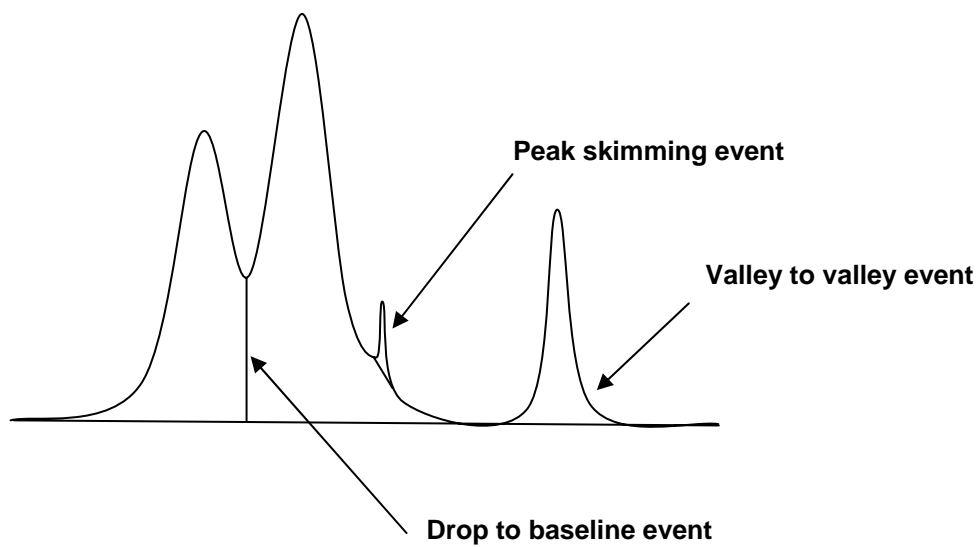

**Figure 2A: TYPICAL PCB PATTERNS**

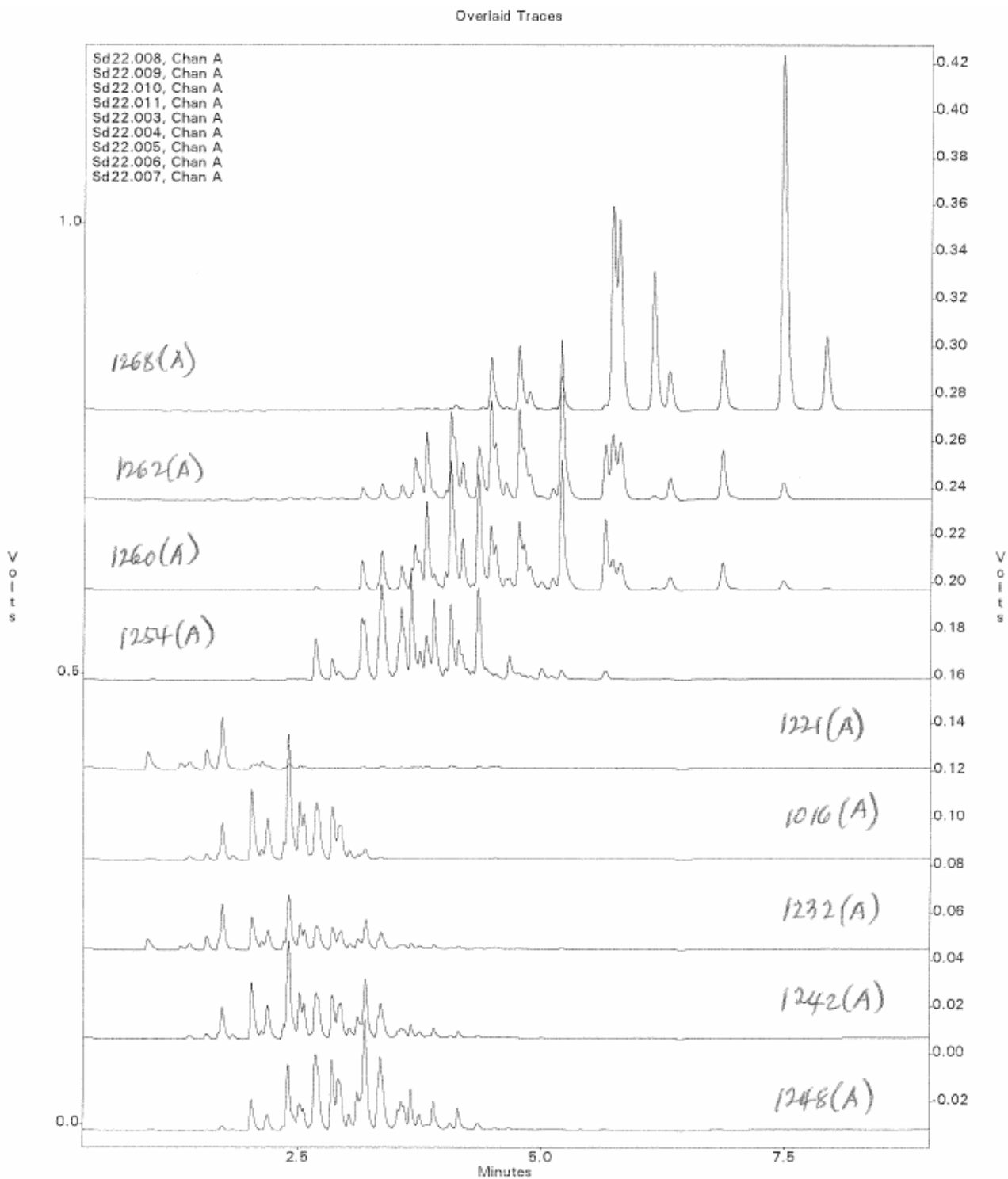
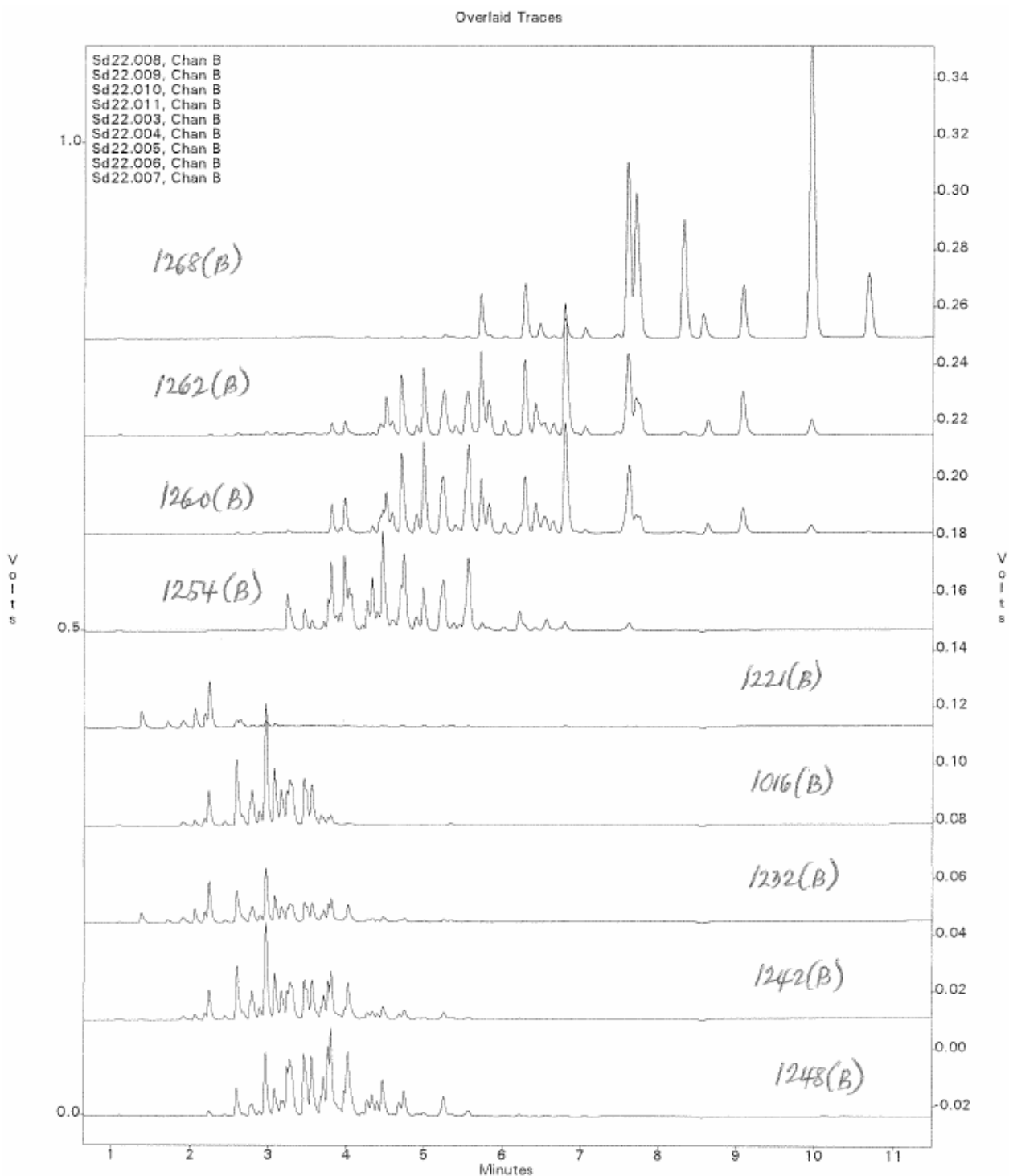
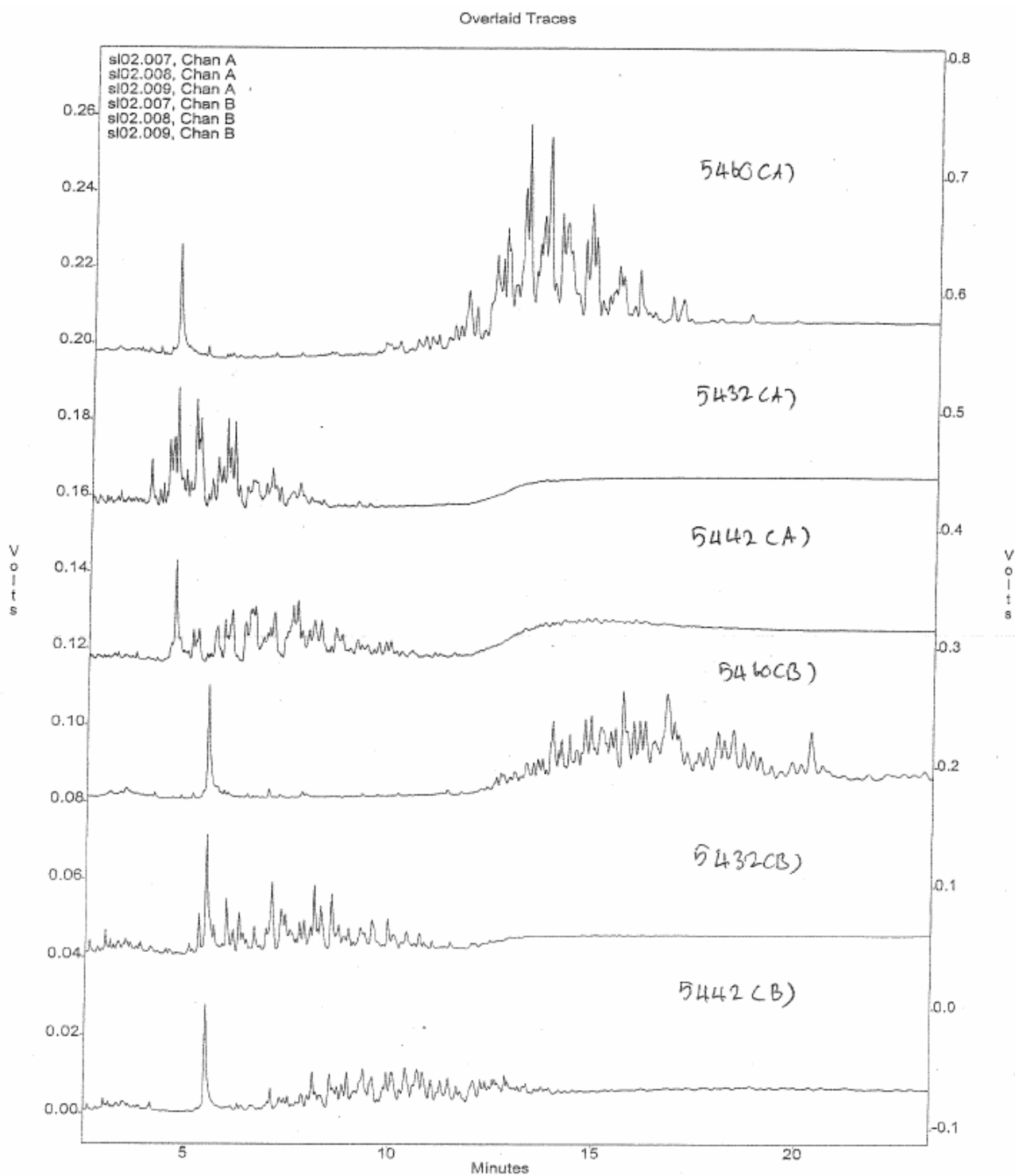

Figure 2A: TYPICAL PCB PATTERNS





**Figure 2B: TYPICAL PCT PATTERNS**



**Figure 3A: TYPICAL 1016 / 1260 CHROMATOGRAM**

EPA 8082 by GC/ECD  
 EMAX Analytical Laboratories, Inc.

File : c:\ezchrom\chrom\sd22\sd22.019  
 Method : c:\ezchrom\methods\6008d22.met  
 Sample ID : I6008D2201 500 PFB  
 Acquired : Apr 22, 2013 16:28:14  
 Printed : Apr 23, 2013 09:56:16  
 User : Supakit

Channel A Results

| #  | Peak Name | Ret.Time(min) | Area   | Ave. CF | ESTD Conc. (ppb) | ICODE |
|----|-----------|---------------|--------|---------|------------------|-------|
| 10 | TCX       | 1.397         | 209505 | 8027.4  | 26.10            | VV    |
| 13 | 1016-1    | 1.727         | 117262 | 1105.5  | 106.07           | SV    |
| 15 | 1016-2    | 2.030         | 208123 | 2115.1  | 98.40            | VV    |
| 17 | 1016-3    | 2.193         | 144013 | 1406.5  | 102.39           | VV    |
| 20 | 1016-4    | 2.523         | 147943 | 1483.4  | 99.73            | VV    |
| 25 | 1016-5    | 2.857         | 158991 | 1530.6  | 103.88           | VV    |
| 37 | 1260-1    | 3.817         | 243941 | 2385.4  | 102.26           | VV    |
| 41 | 1260-2    | 4.067         | 324054 | 3403.5  | 95.21            | VS    |
| 45 | 1260-3    | 4.350         | 381390 | 4078.6  | 93.51            | VV    |
| 50 | 1260-4    | 4.773         | 214219 | 1885.8  | 113.60           | VV    |
| 56 | 1260-5    | 5.657         | 244643 | 2242.9  | 109.08           | VV    |
| 64 | DCB       | 7.923         | 244745 | 9822.7  | 24.92            | VV    |

Channel A Group Results

| #  | Peak Name | Ret.Time(min) | Area    | Ave. CF | ESTD Conc. (ppb) | ICODE |
|----|-----------|---------------|---------|---------|------------------|-------|
| G1 | PCB1016   |               | 776332  | 0.0     | 510.48           |       |
| G2 | PCB1260   |               | 1408247 | 0.0     | 513.66           |       |

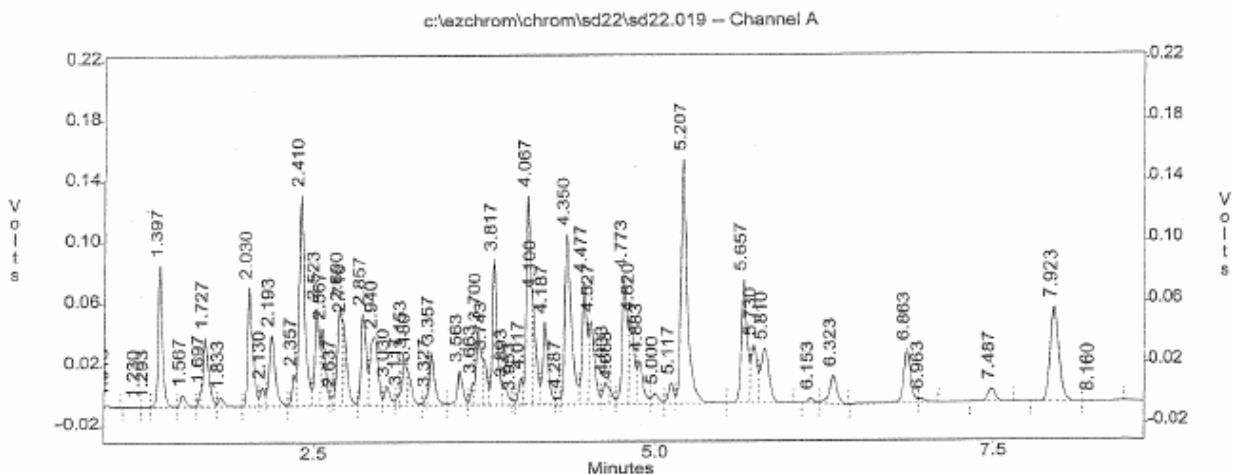

**Figure 3A: TYPICAL 1016 / 1260 CHROMATOGRAM**

EPA 8082 by GC/BCD  
 EMAX Analytical Laboratories, Inc.

File : c:\ezchrom\chrom\sd22\sd22.019  
 Method : c:\ezchrom\methods\6008d22.met  
 Sample ID : I6008D2201 500 PPB  
 Acquired : Apr 22, 2013 16:28:14  
 Printed : Apr 23, 2013 09:56:16  
 User : Supakit

Channel B Results

| #  | Peak Name | Ret.Time(min) | Area   | Ave. CF | ESTD Conc. (ppb) | ICODE |
|----|-----------|---------------|--------|---------|------------------|-------|
| 7  | TCX       | 1.790         | 172868 | 6723.8  | 25.71            | BV    |
| 11 | 1016-1    | 2.250         | 96727  | 909.1   | 106.40           | SV    |
| 17 | 1016-2    | 2.977         | 318468 | 3162.3  | 100.71           | VV    |
| 18 | 1016-3    | 3.090         | 146352 | 1445.4  | 101.25           | VV    |
| 21 | 1016-4    | 3.470         | 96205  | 884.6   | 108.76           | VS    |
| 23 | 1016-5    | 3.567         | 138939 | 1220.9  | 113.80           | VV    |
| 36 | 1260-1    | 4.710         | 242972 | 2525.2  | 96.22            | VV    |
| 38 | 1260-2    | 4.993         | 274421 | 2771.6  | 99.01            | VV    |
| 47 | 1260-3    | 6.290         | 219416 | 1956.9  | 112.12           | SV    |
| 51 | 1260-4    | 6.810         | 452413 | 3935.2  | 114.97           | VV    |
| 55 | 1260-5    | 7.627         | 314588 | 2861.2  | 109.95           | VV    |
| 63 | DCB       | 10.680        | 213337 | 8570.9  | 24.89            | BB    |

Channel B Group Results

| #  | Peak Name | Ret.Time(min) | Area    | Ave. CF | ESTD Conc. (ppb) | ICODE |
|----|-----------|---------------|---------|---------|------------------|-------|
| G1 | PCB1016   |               | 796691  | 0.0     | 530.92           |       |
| G2 | PCB1260   |               | 1503810 | 0.0     | 532.27           |       |

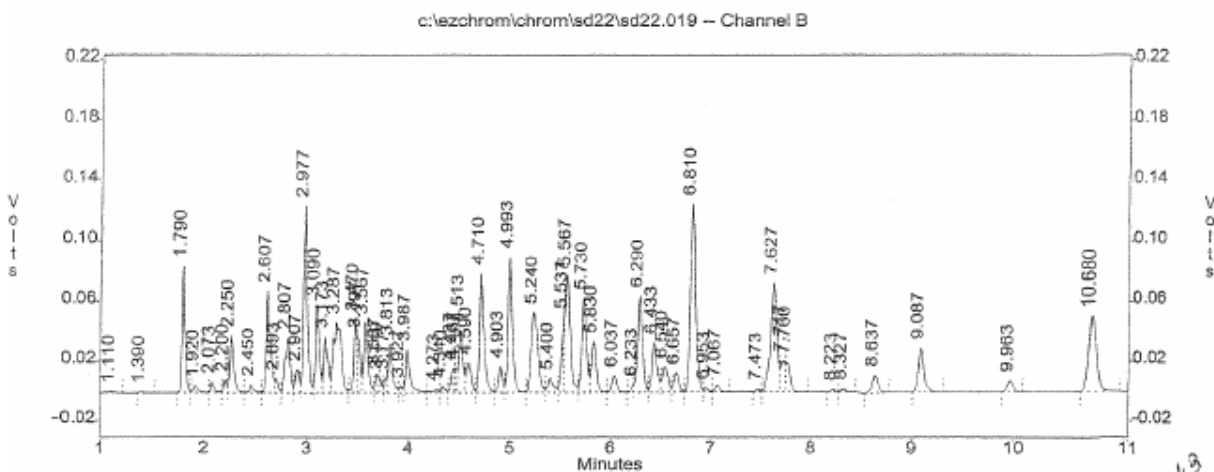

**Figure 3B: TYPICAL 5460 CHROMATOGRAM**

EPA 8082 by GC/ECD  
EMAX Analytical Laboratories, Inc.

File : c:\ezchrom\chrom\s106\s106.006  
Method : c:\ezchrom\methods\4608102.met  
Sample ID : I4608L0202  
Acquired : Dec 06, 2013 21:01:25  
Printed : Dec 09, 2013 09:04:41  
User : Supakit  
Channel A Results

| #  | Peak Name | Ret.Time(min) | Area   | Ave. CF | ESTD Conc. (ppb) | ICODE |
|----|-----------|---------------|--------|---------|------------------|-------|
| 45 | 5460-1    | 11.787        | 42879  | 382.9   | 111.99           | vv    |
| 57 | 5460-2    | 13.240        | 117349 | 1162.2  | 100.98           | vv    |
| 61 | 5460-3    | 13.753        | 204346 | 1900.6  | 107.52           | vv    |
| 68 | 5460-4    | 14.790        | 76920  | 737.2   | 104.34           | vv    |
| 79 | 5460-5    | 15.997        | 58866  | 523.6   | 112.42           | vv    |

Channel A Group Results

| #  | Peak Name | Ret.Time(min) | Area   | Ave. CF | ESTD Conc. (ppb) | ICODE |
|----|-----------|---------------|--------|---------|------------------|-------|
| G1 | PCB5460   |               | 500360 | 0.0     | 537.24           |       |

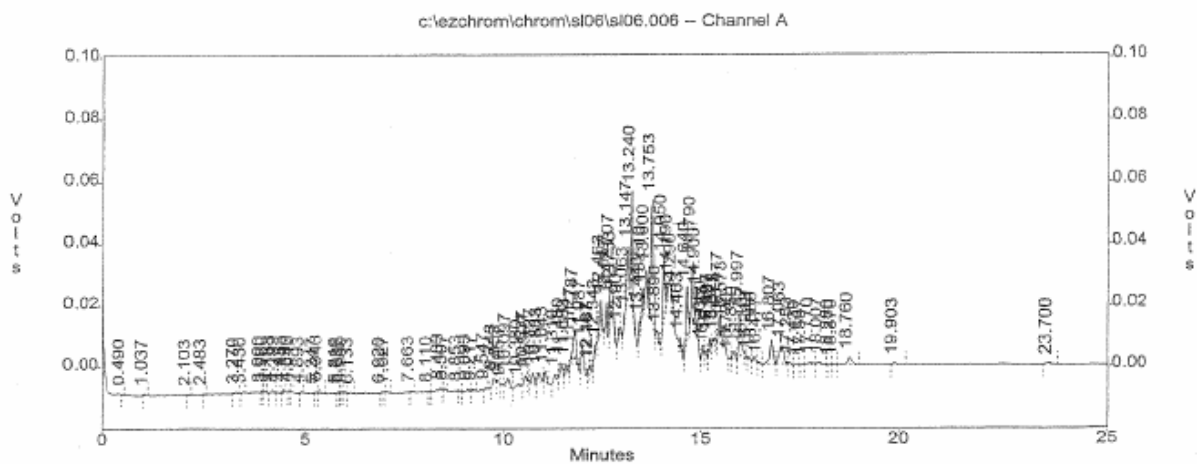

**Figure 3B: TYPICAL 5460 CHROMATOGRAM**

EPA 8082 by GC/ECD  
 EMAX Analytical Laboratories, Inc.

File : c:\ezchrom\chrom\s106\s106.006  
 Method : c:\ezchrom\methods\4608102.met  
 Sample ID : I4608L0202  
 Acquired : Dec 06, 2013 21:01:25  
 Printed : Dec 09, 2013 09:04:42  
 User : Supakit

Channel B Results

| #  | Peak Name | Ret.Time (min) | Area  | Ave. CF | ESTD Conc. (ppb) | ICODE |
|----|-----------|----------------|-------|---------|------------------|-------|
| 43 | 5460-1    | 14.400         | 30916 | 272.9   | 113.27           | vv    |
| 48 | 5460-2    | 14.923         | 34318 | 314.8   | 109.03           | vv    |
| 57 | 5460-3    | 16.143         | 35980 | 350.9   | 102.54           | vv    |
| 71 | 5460-4    | 18.470         | 62839 | 598.4   | 105.01           | vv    |
| 79 | 5460-5    | 20.390         | 88685 | 788.4   | 112.49           | vv    |

Channel B Group Results

| #  | Peak Name | Ret.Time (min) | Area   | Ave. CF | ESTD Conc. (ppb) | ICODE |
|----|-----------|----------------|--------|---------|------------------|-------|
| G1 | PCB5460   |                | 252738 | 0.0     | 542.35           |       |

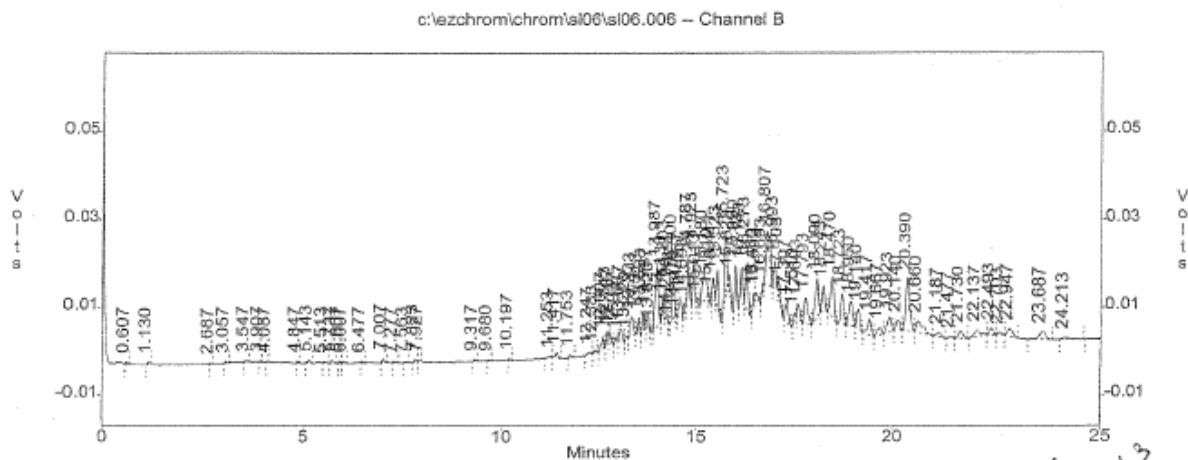

**Figure 4: TYPICAL INITIAL CALIBRATION SUMMARY**

INITIAL CALIBRATION  
 METHOD EPA 8082

Lab Name : EMAX Inc  
 Instrument ID : GCT008 HP-5890  
 GC Column : STX-CLPEST  
 Column size ID : .32MMX30M  
 LFID & Datetime: SD22012A 04/22/13 14:20  
 LFID & Datetime: SD22013A 04/22/13 14:38  
 LFID & Datetime: SD22014A 04/22/13 14:56  
 LFID & Datetime: SD22015A 04/22/13 15:15  
 LFID & Datetime: SD22016A 04/22/13 15:33  
 LFID & Datetime: SD22017A 04/22/13 15:51  
 LFID & Datetime: SD22018A 04/22/13 16:10  
 CONC UNIT: PPB

| COMPOUND  | CONC  | CALIBRATION FACTORS (AREA or HEIGHT)/UNIT |          |          |         |         |         |         |          | MEAN | %RSD |
|-----------|-------|---|----------|----------|---------|---------|---------|---------|----------|------|------|
|           | X     | 1.00X                                     | 2.00X    | 5.00X    | 10.00X  | 20.00X  | 30.00X  | 40.00X  |          |      |      |
| PCB1016-1 | 10.00 | 1245.80                                   | 1264.50  | 1189.94  | 1111.22 | 1010.28 | 970.48  | 946.21  | 1105.489 | 12.0 |      |
| PCB1016-2 | 10.00 | 2536.40                                   | 2564.95  | 2311.70  | 2102.99 | 1854.57 | 1753.11 | 1681.63 | 2115.051 | 17.3 |      |
| PCB1016-3 | 10.00 | 1425.10                                   | 1582.55  | 1504.94  | 1450.07 | 1336.32 | 1287.07 | 1259.39 | 1406.492 | 8.4  |      |
| PCB1016-4 | 10.00 | 1681.50                                   | 1707.10  | 1566.14  | 1517.35 | 1348.08 | 1288.97 | 1274.67 | 1483.401 | 12.2 |      |
| PCB1016-5 | 10.00 | 1690.30                                   | 1689.80  | 1631.86  | 1592.19 | 1427.36 | 1351.14 | 1331.22 | 1530.552 | 10.2 |      |
| PCB1260-1 | 10.00 | 2497.40                                   | 2832.70  | 2665.04  | 2481.41 | 2177.64 | 2050.89 | 1993.05 | 2385.447 | 13.4 |      |
| PCB1260-2 | 10.00 | 3973.20                                   | 3956.45  | 3780.56  | 3401.57 | 3098.52 | 2868.50 | 2745.90 | 3403.528 | 15.1 |      |
| PCB1260-3 | 10.00 | 4233.80                                   | 4253.40  | 4335.62  | 4243.01 | 3950.23 | 3785.45 | 3748.53 | 4078.577 | 6.0  |      |
| PCB1260-4 | 10.00 | 2101.50                                   | 2081.20  | 2016.72  | 1916.13 | 1751.73 | 1651.76 | 1681.37 | 1885.773 | 10.1 |      |
| PCB1260-5 | 10.00 | 2134.00                                   | 2214.35  | 2293.60  | 2318.44 | 2251.94 | 2258.33 | 2229.40 | 2242.865 | 2.7  |      |
| SURROGATE | X     | 1.00X                                     | 2.00X    | 5.00X    | 10.00X  | 20.00X  | 30.00X  | 40.00X  | MEAN     | %RSD |      |
| TCK       | 2.50  | 7622.80                                   | 7776.60  | 8055.92  | 8271.16 | 8180.68 | 8129.51 | 8155.13 | 8027.399 | 3.0  |      |
| DCB       | 2.50  | 10453.20                                  | 10399.60 | 10218.48 | 9930.28 | 9407.84 | 9295.45 | 9054.34 | 9822.742 | 5.8  |      |

**Figure 4: TYPICAL INITIAL CALIBRATION SUMMARY**

INITIAL CALIBRATION  
 METHOD EPA 8082

Lab Name : EMAX Inc  
 Instrument ID : GCT008 HP-5890  
 GC Column : STX-CLPESTII  
 Column size ID : .32MMX30M  
 LFD & Datetime: SD22012B 04/22/13 14:20  
 LFD & Datetime: SD22013B 04/22/13 14:38  
 LFD & Datetime: SD22014B 04/22/13 14:56  
 LFD & Datetime: SD22015B 04/22/13 15:15  
 LFD & Datetime: SD22016B 04/22/13 15:33  
 LFD & Datetime: SD22017B 04/22/13 15:51  
 LFD & Datetime: SD22018B 04/22/13 16:10  
 CONC UNIT: PPB

| COMPOUND  | CONC<br>X | CALIBRATION FACTORS (AREA or HEIGHT)/UNIT |         |         |         |         |         |         |          | MEAN | %RSD |
|-----------|-----------|---|---------|---------|---------|---------|---------|---------|----------|------|------|
|           |           | 1.00X                                     | 2.00X   | 5.00X   | 10.00X  | 20.00X  | 30.00X  | 40.00X  |          |      |      |
| PCB1016-1 | 10.00     | 1034.90                                   | 1003.55 | 953.56  | 920.08  | 849.59  | 802.65  | 799.27  | 909.085  | 10.4 |      |
| PCB1016-2 | 10.00     | 3364.00                                   | 3348.40 | 3263.74 | 3246.16 | 3052.13 | 2942.87 | 2918.57 | 3162.267 | 5.9  |      |
| PCB1016-3 | 10.00     | 1584.70                                   | 1590.05 | 1499.06 | 1500.07 | 1363.26 | 1304.63 | 1275.93 | 1445.386 | 9.0  |      |
| PCB1016-4 | 10.00     | 963.20                                    | 981.50  | 1005.26 | 968.37  | 838.92  | 732.73  | 702.08  | 884.580  | 14.3 |      |
| PCB1016-5 | 10.00     | 1367.40                                   | 1287.35 | 1139.18 | 1278.94 | 1183.28 | 1143.45 | 1146.65 | 1220.892 | 7.4  |      |
| PCB1260-1 | 10.00     | 2912.20                                   | 2828.30 | 2682.28 | 2523.60 | 2337.13 | 2210.23 | 2182.43 | 2525.167 | 11.6 |      |
| PCB1260-2 | 10.00     | 3263.30                                   | 3140.35 | 2941.88 | 2793.55 | 2541.98 | 2376.99 | 2343.39 | 2771.633 | 13.2 |      |
| PCB1260-3 | 10.00     | 2107.30                                   | 2115.55 | 2022.06 | 1964.61 | 1867.61 | 1817.69 | 1803.59 | 1956.917 | 6.7  |      |
| PCB1260-4 | 10.00     | 4053.80                                   | 4073.20 | 4062.68 | 4003.42 | 3836.75 | 3766.36 | 3750.01 | 3935.174 | 3.7  |      |
| PCB1260-5 | 10.00     | 2839.40                                   | 2874.40 | 2904.04 | 2900.47 | 2847.30 | 2830.45 | 2832.44 | 2861.214 | 1.1  |      |
| SURROGATE | X         | 1.00X                                     | 2.00X   | 5.00X   | 10.00X  | 20.00X  | 30.00X  | 40.00X  | MEAN     | %RSD |      |
| TCX       | 2.50      | 6348.80                                   | 6425.00 | 6637.36 | 6860.32 | 6902.80 | 6900.67 | 6991.45 | 6723.771 | 3.8  |      |
| DCB       | 2.50      | 8916.00                                   | 8977.60 | 8898.88 | 8667.16 | 8279.26 | 8188.12 | 8069.01 | 8570.861 | 4.5  |      |

**Figure 4: TYPICAL INITIAL CALIBRATION SUMMARY**

INITIAL CALIBRATION  
 METHOD EPA 8082

Lab Name : EMAX Inc  
 Instrument ID : 08 HP-5890  
 GC Column : STX-CLPESTICIDES  
 Column size ID : .32MMID X 30MM X 0.32UM DF  
 LFD & Datetime: SLO2010A 12/02/13 22:05  
 LFD & Datetime: SLO2011A 12/02/13 22:40  
 LFD & Datetime: SLO2012A 12/02/13 23:15  
 LFD & Datetime: SLO2013A 12/02/13 23:50  
 LFD & Datetime: SLO2014A 12/03/13 00:25  
 LFD & Datetime: SLO2015A 12/03/13 00:59  
 LFD & Datetime: SLO2016A 12/03/13 01:34  
 CONC UNIT: PPB

| COMPOUND  | CALIBRATION FACTORS (AREA or HEIGHT)/UNIT |         |         |         |         |         |         |         |          | MEAN | %RSD |
|-----------|---|---------|---------|---------|---------|---------|---------|---------|----------|------|------|
|           | CONC X                                    | 1.00X   | 2.00X   | 5.00X   | 10.00X  | 20.00X  | 30.00X  | 40.00X  |          |      |      |
| PCB5460-1 | 10.00                                     | 345.60  | 408.85  | 400.44  | 387.18  | 378.08  | 381.47  | 378.63  | 382.893  | 5.3  |      |
| PCB5460-2 | 10.00                                     | 1402.30 | 1398.15 | 1239.96 | 1139.28 | 1034.54 | 973.24  | 947.60  | 1162.152 | 16.4 |      |
| PCB5460-3 | 10.00                                     | 2122.80 | 2141.90 | 1980.30 | 1872.49 | 1786.00 | 1726.26 | 1674.43 | 1900.597 | 9.8  |      |
| PCB5460-4 | 10.00                                     | 809.60  | 825.05  | 770.08  | 736.05  | 694.23  | 671.68  | 653.54  | 737.176  | 9.1  |      |
| PCB5460-5 | 10.00                                     | 499.30  | 538.00  | 653.86  | 496.06  | 496.83  | 492.63  | 488.66  | 523.620  | 11.4 |      |

INITIAL CALIBRATION  
 METHOD EPA 8082

Lab Name : EMAX Inc  
 Instrument ID : GCT008 HP-5890  
 GC Column : STX-CLPESTICIDES II  
 Column size ID : .32MMID X 30MM X 0.25UM DF  
 LFD & Datetime: SLO2010B 12/02/13 22:05  
 LFD & Datetime: SLO2011B 12/02/13 22:40  
 LFD & Datetime: SLO2012B 12/02/13 23:15  
 LFD & Datetime: SLO2013B 12/02/13 23:50  
 LFD & Datetime: SLO2014B 12/03/13 00:25  
 LFD & Datetime: SLO2015B 12/03/13 00:59  
 LFD & Datetime: SLO2016B 12/03/13 01:34  
 CONC UNIT: PPB

| COMPOUND  | CALIBRATION FACTORS (AREA or HEIGHT)/UNIT |        |        |        |        |        |        |        |         | MEAN | %RSD |
|-----------|---|--------|--------|--------|--------|--------|--------|--------|---------|------|------|
|           | CONC X                                    | 1.00X  | 2.00X  | 5.00X  | 10.00X | 20.00X | 30.00X | 40.00X |         |      |      |
| PCB5460-1 | 10.00                                     | 304.40 | 303.00 | 284.96 | 269.06 | 256.69 | 249.62 | 242.87 | 272.944 | 9.2  |      |
| PCB5460-2 | 10.00                                     | 350.10 | 358.55 | 334.00 | 310.81 | 293.42 | 281.35 | 275.07 | 314.758 | 10.6 |      |
| PCB5460-3 | 10.00                                     | 387.10 | 393.65 | 364.36 | 346.38 | 331.02 | 319.98 | 313.67 | 350.880 | 9.1  |      |
| PCB5460-4 | 10.00                                     | 634.40 | 657.85 | 611.10 | 589.84 | 573.43 | 563.00 | 559.06 | 598.383 | 6.3  |      |
| PCB5460-5 | 10.00                                     | 826.70 | 839.15 | 797.92 | 775.96 | 766.59 | 756.85 | 755.39 | 788.364 | 4.3  |      |



**Figure 5: TYPICAL RETENTION TIME WINDOW SUMMARY**

INITIAL CALIBRATION  
 METHOD EPA 8082

Lab Name : EMAX Inc  
 Instrument ID : GCT008 HP-5890  
 GC Column : STX-CLPEST  
 Column size ID : .32MMX30M  
 LFID & Datetime: SD22012A 04/22/13 14:20  
 LFID & Datetime: SD22013A 04/22/13 14:38  
 LFID & Datetime: SD22014A 04/22/13 14:56  
 LFID & Datetime: SD22015A 04/22/13 15:15  
 LFID & Datetime: SD22016A 04/22/13 15:33  
 LFID & Datetime: SD22017A 04/22/13 15:51  
 LFID & Datetime: SD22018A 04/22/13 16:10

| COMPOUND  | RT OF STANDARDS (MIN) |       |       |       |       |       |       | MEAN RT | RT WINDOW |       | RTWINDOW WIDTH |
|-----------|-----------------------|-------|-------|-------|-------|-------|-------|---------|-----------|-------|----------------|
|           | 1.0X                  | 2.0X  | 5.0X  | 10.0X | 20.0X | 30.0X | 40.0X |         | FROM      | TO    |                |
| PCB1016-1 | 1.727                 | 1.727 | 1.727 | 1.727 | 1.723 | 1.723 | 1.723 | 1.725   | 1.713     | 1.737 | 0.012          |
| PCB1016-2 | 2.033                 | 2.033 | 2.033 | 2.030 | 2.030 | 2.030 | 2.030 | 2.031   | 2.020     | 2.042 | 0.011          |
| PCB1016-3 | 2.197                 | 2.193 | 2.193 | 2.193 | 2.190 | 2.193 | 2.190 | 2.193   | 2.182     | 2.204 | 0.011          |
| PCB1016-4 | 2.523                 | 2.520 | 2.523 | 2.520 | 2.520 | 2.520 | 2.520 | 2.521   | 2.510     | 2.532 | 0.011          |
| PCB1016-5 | 2.857                 | 2.857 | 2.857 | 2.857 | 2.853 | 2.857 | 2.853 | 2.856   | 2.845     | 2.867 | 0.011          |
| PCB1260-1 | 3.817                 | 3.813 | 3.817 | 3.813 | 3.813 | 3.813 | 3.813 | 3.814   | 3.798     | 3.830 | 0.016          |
| PCB1260-2 | 4.070                 | 4.067 | 4.067 | 4.067 | 4.063 | 4.067 | 4.063 | 4.066   | 4.046     | 4.086 | 0.020          |
| PCB1260-3 | 4.350                 | 4.347 | 4.350 | 4.347 | 4.347 | 4.347 | 4.347 | 4.348   | 4.327     | 4.369 | 0.021          |
| PCB1260-4 | 4.773                 | 4.773 | 4.773 | 4.770 | 4.770 | 4.773 | 4.770 | 4.772   | 4.746     | 4.798 | 0.026          |
| PCB1260-5 | 5.657                 | 5.657 | 5.657 | 5.653 | 5.657 | 5.657 | 5.653 | 5.656   | 5.625     | 5.687 | 0.031          |
| SURROGATE | 1.0X                  | 2.0X  | 5.0X  | 10.0X | 20.0X | 30.0X | 40.0X | RT      | FROM      | TO    | WIDTH          |
| TCX       | 1.393                 | 1.393 | 1.397 | 1.393 | 1.393 | 1.393 | 1.393 | 1.394   | 1.383     | 1.405 | 0.011          |
| DCB       | 7.920                 | 7.920 | 7.923 | 7.917 | 7.920 | 7.920 | 7.920 | 7.920   | 7.874     | 7.966 | 0.046          |

**Figure 5: TYPICAL RETENTION TIME WINDOW SUMMARY**

INITIAL CALIBRATION  
 METHOD EPA 8082

Lab Name : EMAX Inc  
 Instrument ID : GCT008 HP-5890  
 GC Column : STX-CLPEST11  
 Column size ID : .32MMX30M  
 LFID & Datetime: SD22012B 04/22/13 14:20  
 LFID & Datetime: SD22013B 04/22/13 14:38  
 LFID & Datetime: SD22014B 04/22/13 14:56  
 LFID & Datetime: SD22015B 04/22/13 15:15  
 LFID & Datetime: SD22016B 04/22/13 15:33  
 LFID & Datetime: SD22017B 04/22/13 15:51  
 LFID & Datetime: SD22018B 04/22/13 16:10

| COMPOUND  | RT OF STANDARDS (MIN) |        |        |        |        |        |        | MEAN RT | RT WINDOW |        | RTWINDOW WIDTH |
|-----------|-----------------------|--------|--------|--------|--------|--------|--------|---------|-----------|--------|----------------|
|           | 1.0X                  | 2.0X   | 5.0X   | 10.0X  | 20.0X  | 30.0X  | 40.0X  |         | FROM      | TO     |                |
| PCB1016-1 | 2.250                 | 2.250  | 2.250  | 2.250  | 2.250  | 2.250  | 2.250  | 2.250   | 2.239     | 2.261  | 0.011          |
| PCB1016-2 | 2.977                 | 2.977  | 2.977  | 2.977  | 2.973  | 2.977  | 2.977  | 2.976   | 2.964     | 2.988  | 0.012          |
| PCB1016-3 | 3.090                 | 3.090  | 3.093  | 3.090  | 3.090  | 3.090  | 3.090  | 3.090   | 3.078     | 3.102  | 0.012          |
| PCB1016-4 | 3.470                 | 3.467  | 3.470  | 3.467  | 3.467  | 3.467  | 3.467  | 3.468   | 3.452     | 3.484  | 0.016          |
| PCB1016-5 | 3.567                 | 3.563  | 3.567  | 3.567  | 3.563  | 3.567  | 3.563  | 3.565   | 3.554     | 3.576  | 0.011          |
| PCB1260-1 | 4.713                 | 4.710  | 4.713  | 4.710  | 4.707  | 4.710  | 4.707  | 4.710   | 4.684     | 4.736  | 0.026          |
| PCB1260-2 | 4.993                 | 4.993  | 4.993  | 4.990  | 4.990  | 4.993  | 4.990  | 4.992   | 4.968     | 5.016  | 0.024          |
| PCB1260-3 | 6.287                 | 6.287  | 6.290  | 6.287  | 6.287  | 6.287  | 6.287  | 6.287   | 6.252     | 6.322  | 0.035          |
| PCB1260-4 | 6.810                 | 6.807  | 6.810  | 6.807  | 6.807  | 6.810  | 6.810  | 6.809   | 6.770     | 6.848  | 0.039          |
| PCB1260-5 | 7.623                 | 7.623  | 7.627  | 7.623  | 7.623  | 7.627  | 7.627  | 7.625   | 7.579     | 7.671  | 0.046          |
| SURROGATE | 1.0X                  | 2.0X   | 5.0X   | 10.0X  | 20.0X  | 30.0X  | 40.0X  | RT      | FROM      | TO     | WIDTH          |
| TCX       | 1.787                 | 1.790  | 1.790  | 1.790  | 1.787  | 1.787  | 1.787  | 1.788   | 1.776     | 1.800  | 0.012          |
| DCB       | 10.677                | 10.677 | 10.680 | 10.677 | 10.673 | 10.677 | 10.680 | 10.677  | 10.650    | 10.704 | 0.027          |

**Figure 5: TYPICAL RETENTION TIME WINDOW SUMMARY**

INITIAL CALIBRATION  
 METHOD EPA 8082

Lab Name : EMAX Inc  
 Instrument ID : 08 HP-5890  
 GC Column : STX-CLPESTICIDES  
 Column size ID : .32MMID X 30MM X 0.32UM DF  
 LFID & Datetime: SLO2010A 12/02/13 22:05  
 LFID & Datetime: SLO2011A 12/02/13 22:40  
 LFID & Datetime: SLO2012A 12/02/13 23:15  
 LFID & Datetime: SLO2013A 12/02/13 23:50  
 LFID & Datetime: SLO2014A 12/03/13 00:25  
 LFID & Datetime: SLO2015A 12/03/13 00:59  
 LFID & Datetime: SLO2016A 12/03/13 01:34

| COMPOUND  | RT OF STANDARDS (MIN) |        |        |        |        |        |        | MEAN RT | RT WINDOW |        | RTWINDOW WIDTH |
|-----------|-----------------------|--------|--------|--------|--------|--------|--------|---------|-----------|--------|----------------|
|           | 1.0X                  | 2.0X   | 5.0X   | 10.0X  | 20.0X  | 30.0X  | 40.0X  |         | FROM      | TO     |                |
| PCB5460-1 | 11.757                | 11.763 | 11.767 | 11.773 | 11.783 | 11.787 | 11.793 | 11.775  | 11.763    | 11.787 | 0.012          |
| PCB5460-2 | 13.227                | 13.233 | 13.233 | 13.237 | 13.240 | 13.247 | 13.247 | 13.238  | 13.231    | 13.245 | 0.007          |
| PCB5460-3 | 13.737                | 13.743 | 13.747 | 13.750 | 13.753 | 13.763 | 13.763 | 13.751  | 13.735    | 13.767 | 0.016          |
| PCB5460-4 | 14.767                | 14.780 | 14.780 | 14.787 | 14.790 | 14.803 | 14.803 | 14.787  | 14.775    | 14.799 | 0.012          |
| PCB5460-5 | 15.970                | 15.983 | 15.990 | 15.993 | 16.003 | 16.017 | 16.020 | 15.997  | 15.986    | 16.008 | 0.011          |

INITIAL CALIBRATION  
 METHOD EPA 8082

Lab Name : EMAX Inc  
 Instrument ID : GCT00B HP-5890  
 GC Column : STX-CLPESTICIDES II  
 Column size ID : .32MMID X 30MM X 0.25UM DF  
 LFID & Datetime: SLO2010B 12/02/13 22:05  
 LFID & Datetime: SLO2011B 12/02/13 22:40  
 LFID & Datetime: SLO2012B 12/02/13 23:15  
 LFID & Datetime: SLO2013B 12/02/13 23:50  
 LFID & Datetime: SLO2014B 12/03/13 00:25  
 LFID & Datetime: SLO2015B 12/03/13 00:59  
 LFID & Datetime: SLO2016B 12/03/13 01:34

| COMPOUND  | RT OF STANDARDS (MIN) |        |        |        |        |        |        | MEAN RT | RT WINDOW |        | RTWINDOW WIDTH |
|-----------|-----------------------|--------|--------|--------|--------|--------|--------|---------|-----------|--------|----------------|
|           | 1.0X                  | 2.0X   | 5.0X   | 10.0X  | 20.0X  | 30.0X  | 40.0X  |         | FROM      | TO     |                |
| PCB5460-1 | 14.380                | 14.390 | 14.393 | 14.393 | 14.400 | 14.413 | 14.413 | 14.397  | 14.388    | 14.406 | 0.009          |
| PCB5460-2 | 14.900                | 14.913 | 14.917 | 14.920 | 14.927 | 14.940 | 14.940 | 14.922  | 14.911    | 14.933 | 0.011          |
| PCB5460-3 | 16.120                | 16.133 | 16.140 | 16.143 | 16.153 | 16.167 | 16.170 | 16.147  | 16.132    | 16.162 | 0.015          |
| PCB5460-4 | 18.443                | 18.460 | 18.470 | 18.470 | 18.497 | 18.507 | 18.513 | 18.480  | 18.460    | 18.500 | 0.020          |
| PCB5460-5 | 20.363                | 20.373 | 20.393 | 20.397 | 20.423 | 20.433 | 20.440 | 20.403  | 20.366    | 20.440 | 0.037          |

**Figure 6: TYPICAL SAMPLE RESULT SUMMARY**

METHOD 3546/8082  
 PCBs

```

=====
Client       : XYZ, INC.
Project      : CLEAN LAND
Batch No.    : 14E102
Sample ID    : BVBS1265S001
Lab Samp ID  : E102-03
Lab File ID  : SE22008A
Ext Btch ID  : CPE022S
Calib. Ref. : SE22002A

Date Collected: 05/13/14
Date Received: 05/14/14
Date Extracted: 05/20/14 13:18
Date Analyzed: 05/22/14 19:37
Dilution Factor: 1
Matrix       : SOIL
% Moisture   : 3.6
Instrument ID : GCT008
=====
  
```

| PARAMETERS           | RESULTS<br>(ug/kg) | RL<br>(ug/kg) | MDL<br>(ug/kg) |  |          |
|----------------------|--------------------|---------------|----------------|--|----------|
| AROCLOR 1016         | (ND)   ND          | 18            | 8.8   8.8      |  |          |
| AROCLOR 1221         | (ND)   ND          | 34            | 18   18        |  |          |
| AROCLOR 1232         | (ND)   ND          | 18            | 8.8   8.8      |  |          |
| AROCLOR 1242         | (ND)   ND          | 18            | 8.8   8.8      |  |          |
| AROCLOR 1248         | (ND)   ND          | 18            | 8.8   8.8      |  |          |
| AROCLOR 1254         | (ND)   ND          | 18            | 8.8   8.8      |  |          |
| AROCLOR 1260         | (ND)   ND          | 18            | 8.8   8.8      |  |          |
| AROCLOR 1262         | (ND)   ND          | 34            | 18   18        |  |          |
| AROCLOR 1268         | (ND)   ND          | 34            | 18   18        |  |          |
| AROCLOR 5432         | (ND)   ND          | 52            | 26   26        |  |          |
| AROCLOR 5442         | (ND)   ND          | 52            | 26   26        |  |          |
| AROCLOR 5460         | (ND)   ND          | 52            | 26   26        |  |          |
|                      |                    |               |                |  |          |
| SURROGATE PARAMETERS | RESULTS            | SPK_AMT       | % RECOVERY     |  | QC LIMIT |
| DECACHLOROBIPHENYL   | (14.21)   12.68    | 13.83         | (103)   91.7   |  | 45-120   |

Left of | is related to first column ; Right of | related to second column  
 Final result indicated by ( )  
 \* out side of QC Limit

**Figure 7: TYPICAL LCS/LCSD SUMMARY**

EMAX QUALITY CONTROL DATA  
 LCS ANALYSIS

CLIENT: XYZ, INC.  
 PROJECT: CLEAN LAND  
 BATCH NO.: 14E102  
 METHOD: METHOD 3546/8082

MATRIX: SOIL % MOISTURE: NA  
 DILUTION FACTOR: 1 1  
 SAMPLE ID: MBLK1S  
 LAB SAMP ID: 60E022SB 60E022SL  
 LAB FILE ID: SE22005A SE22006A  
 DATE EXTRACTED: 05/20/1413:18 05/20/1413:18 DATE COLLECTED: NA  
 DATE ANALYZED: 05/22/1417:52 05/22/1418:27 DATE RECEIVED: 05/20/13  
 PREP. BATCH: CPE0225 CPE0225  
 CALIB. REF: SE22002A SE22002A

ACCESSION:

| PARAMETER    | BLNK RSLT<br>(ug/kg) | SPIKE AMT<br>(ug/kg) | BS RSLT<br>(ug/kg) | BS<br>% REC | SPIKE AMT<br>(ug/kg) | BSD RSLT<br>(ug/kg) | BS<br>% REC | RPD<br>(%) | QC LIMIT<br>(%) | MAX RPD<br>(%) |
|--------------|----------------------|----------------------|--------------------|-------------|----------------------|---------------------|-------------|------------|-----------------|----------------|
| Aroclor 1016 | (ND) ND              | 167                  | (171) 163          | (103) 98    | 167                  | (173) 161           | (104) 96    | (1) 1      | 50-150          | 30             |
| Aroclor 1260 | (ND) ND              | 167                  | 159 (162)          | 95 (97)     | 167                  | 158 (165)           | 95 (99)     | 1 (2)      | 50-150          | 30             |
| Aroclor 5460 | (ND) ND              | 83.3                 | (88.3) 84.9        | (106) 102   | 83.3                 | (90.0) 86.1         | (108) 103   | (2) 1      | 50-150          | 30             |

| SURROGATE PARAMETER | SPIKE AMT<br>(ug/kg) | BS RSLT<br>(ug/kg) | BS<br>% REC | SPIKE AMT<br>(ug/kg) | BS RSLT<br>(ug/kg) | BS<br>% REC | QC LIMIT<br>(%) |
|---------------------|----------------------|--------------------|-------------|----------------------|--------------------|-------------|-----------------|
| Decachlorobiphenyl  | 13.33                | 16.87 (14.87)      | 127* (112)  | 13.33                | 16.13 15.01        | 121* (113)  | 45-120          |

**Figure 8: TYPICAL MS/MSD SUMMARY**

EMAX QUALITY CONTROL DATA  
 MS/MSD ANALYSIS

CLIENT: XYZ, INC.  
 PROJECT: CLEAN LAND  
 BATCH NO.: 14E102  
 METHOD: METHOD 3546/8082

MATRIX: SOIL % MOISTURE: 3.6  
 DILUTION FACTOR: 1 1 1  
 SAMPLE ID: BVBS1265S001  
 LAB SAMP ID: E102-03M E102-03S  
 LAB FILE ID: SE22008A SE22009A SE22010A  
 DATE EXTRACTED: 05/20/1413:18 05/20/1413:18 05/20/1413:18 DATE COLLECTED: 05/13/14  
 DATE ANALYZED: 05/22/1419:37 05/22/1420:11 05/22/1420:46 DATE RECEIVED: 05/14/14  
 PREP. BATCH: CPE022S CPE022S CPE022S  
 CALIB. REF: SE22002A SE22002A SE22002A

ACCESSION:

| PARAMETER    | SMPL RSLT<br>(ug/kg) | SPIKE AMT<br>(ug/kg) | MS RSLT<br>(ug/kg) | MS<br>% REC | SPIKE AMT<br>(ug/kg) | MSD RSLT<br>(ug/kg) | MSD<br>% REC | RPD<br>(%) | QC LIMIT<br>(%) | MAX RPD<br>(%) |
|--------------|----------------------|----------------------|--------------------|-------------|----------------------|---------------------|--------------|------------|-----------------|----------------|
| Aroclor 1016 | (ND) ND              | 173                  | (155) 176          | (90) 102    | 173                  | (163) 152           | (94) 88      | (4) 15     | 29-135          | 30             |
| Aroclor 1260 | (ND) ND              | 173                  | (165) 165          | (95) 95     | 173                  | (164) 141           | (95) 82      | (1) 16     | 29-135          | 30             |
| Aroclor 5460 | (ND) ND              | 86.4                 | 90.1 (93.3)        | 104 (108)   | 86.4                 | (83.9) 79.5         | (97) 92      | (7) 16     | 29-135          | 30             |

| SURROGATE PARAMETER | SPIKE AMT<br>(ug/kg) | MS RSLT<br>(ug/kg) | MS<br>% REC | SPIKE AMT<br>(ug/kg) | MSD RSLT<br>(ug/kg) | MSD<br>% REC | QC LIMIT<br>(%) |
|---------------------|----------------------|--------------------|-------------|----------------------|---------------------|--------------|-----------------|
| Decachlorobiphenyl  | 13.83                | (16.36) 14.64      | (118) 106   | 13.83                | (14.44) 12.73       | (104) 92.1   | 45-120          |

**Figure 9: TYPICAL CASE NARRATIVE**

---

CASE NARRATIVE

Client : XYZ, INC.  
Project : CLEAN LAND  
SDG : 14E102

METHOD 3520C/3546/8082  
PCBs

A total of six (6) soil samples were received on 05/14/14 for PCBs and PCTs analysis, Method 3546/8082 in accordance with USEPA SW-846, Test Methods for Evaluating Solid Waste, Physical/Chemical Methods.

Holding Time

Samples were analyzed within the prescribed holding time.

Calibration

Multi-calibration points were generated to establish initial calibration (ICAL). ICAL was verified using a secondary source (ICV). Continuing calibration (CCV) verifications were carried on a frequency specified by the project. All calibration requirements were within acceptance criteria. Refer to calibration summary forms of ICAL, ICV and CCV for details.

Method Blank

Method blanks were analyzed at the frequency required by the project. For this SDG, one (1) method blank was analyzed with the samples. Results were compliant to project requirement.

Lab Control Sample

A set of LCS/LCD and lab control sample was analyzed with the samples in this SDG. Percent recoveries for 60E022SL/C were all within QC limits.

Matrix QC Sample

A set of MS/MSD was analyzed with the samples in this SDG. Percent recoveries for E102-03M/S were within project QC limits.

Surrogate

Surrogate was added on QC and field samples. Surrogate recoveries were within project QC limits. Refer to sample result forms for details.

Sample Analysis

Samples were analyzed according to prescribed analytical procedures. All project requirements were met; otherwise, anomalies were discussed within the associated QC parameter. Sample extracts subjected to appropriate cleanup technique to reduce matrix interference are recorded in extraction log.

**Table 1: INTERMEDIATE STANDARD PREPARATION**

| Standard Name    | Stock Standard Conc. (ppm) | Preparation  |         |                 | Final Conc. (µg/L) |
|------------------|----------------------------|--------------|---------|-----------------|--------------------|
|                  |                            | Aliquot (ml) | Solvent | Final Vol. (ml) |                    |
| PCB 1016         | 1000                       | 0.4          | Hexane  | 100             | 4000               |
| PCB 1260         | 1000                       | 0.4          | Hexane  | 100             | 4000               |
| PCB 1221         | 1000                       | 0.4          | Hexane  | 100             | 4000               |
| PCB 1232         | 1000                       | 0.4          | Hexane  | 100             | 4000               |
| PCB 1242         | 1000                       | 0.4          | Hexane  | 100             | 4000               |
| PCB 1248         | 1000                       | 0.4          | Hexane  | 100             | 4000               |
| PCB 1254         | 1000                       | 0.4          | Hexane  | 100             | 4000               |
| PCB 1262         | 1000                       | 0.4          | Hexane  | 100             | 4000               |
| PCB 1268         | 1000                       | 0.4          | Hexane  | 100             | 4000               |
| PCT 5460         | 1000                       | 0.4          | Hexane  | 100             | 4000               |
| PCT 5432         | 1000                       | 0.4          | Hexane  | 100             | 4000               |
| PCT5442          | 1000                       | 0.4          | Hexane  | 100             | 4000               |
| <b>Surrogate</b> |                            |              |         |                 |                    |
| TCX              | 200                        | 0.1          | Hexane  | 100             | 200                |
| DCB              | 200                        | 0.1          | Hexane  | 100             | 200                |



**Table 2: INITIAL CALIBRATION STANDARD PREPARATION**

| Standard # | Standard Name       | Intermediate Std. (µg/L) | Preparation  |         |                 | Final Conc. (µg/L) |
|------------|---------------------|--------------------------|--------------|---------|-----------------|--------------------|
|            |                     |                          | Aliquot (µl) | Solvent | Final Vol. (µl) |                    |
| 1          | PCB 1660 / PCT 5460 | 4000                     | 10           | Hexane  | 800             | 50                 |
|            | Surrogate           | 200                      |              |         |                 | 2.5                |
| 2          | PCB 1660 / PCT 5460 | 4000                     | 20           | Hexane  | 800             | 100                |
|            | Surrogate           | 200                      |              |         |                 | 5                  |
| 3          | PCB 1660 / PCT 5460 | 4000                     | 50           | Hexane  | 800             | 250                |
|            | Surrogate           | 200                      |              |         |                 | 12.5               |
| 4          | PCB 1660 / PCT 5460 | 4000                     | 100          | Hexane  | 800             | 500                |
|            | Surrogate           | 200                      |              |         |                 | 25                 |
| 5          | PCB 1660 / PCT 5460 | 4000                     | 200          | Hexane  | 800             | 1000               |
|            | Surrogate           | 200                      |              |         |                 | 50                 |
| 6          | PCB 1660 / PCT 5460 | 4000                     | 300          | Hexane  | 800             | 1500               |
|            | Surrogate           | 200                      |              |         |                 | 75                 |
| 7          | PCB 1660 / PCT 5460 | 4000                     | 400          | Hexane  | 800             | 2000               |
|            | Surrogate           | 200                      |              |         |                 | 100                |

**Table 3: CALIBRATION CHECK STANDARD PREPARATION**

| Standard Name    | Intermediate Standard Conc. (µg/L) | Preparation  |         |                 | Final Conc. (µg/L) |
|------------------|------------------------------------|--------------|---------|-----------------|--------------------|
|                  |                                    | Aliquot (µl) | Solvent | Final Vol. (µl) |                    |
| PCB 1016         | 4000                               | 100          | Hexane  | 800             | 500                |
| PCB 1260         | 4000                               | 100          | Hexane  | 800             | 500                |
| PCB 1221         | 4000                               | 100          | Hexane  | 800             | 500                |
| PCB 1232         | 4000                               | 100          | Hexane  | 800             | 500                |
| PCB 1242         | 4000                               | 100          | Hexane  | 800             | 500                |
| PCB 1248         | 4000                               | 100          | Hexane  | 800             | 500                |
| PCB 1254         | 4000                               | 100          | Hexane  | 800             | 500                |
| PCB 1262         | 4000                               | 100          | Hexane  | 800             | 500                |
| PCB 1268         | 4000                               | 100          | Hexane  | 800             | 500                |
| PCT 5460         | 4000                               | 100          | Hexane  | 800             | 500                |
| PCT 5432         | 4000                               | 100          | Hexane  | 800             | 500                |
| PCT 5442         | 4000                               | 100          | Hexane  | 800             | 500                |
| <b>Surrogate</b> |                                    |              |         |                 |                    |
| TCX              | 200                                | 100          | Hexane  | 800             | 25                 |
| DCB              | 200                                | 100          | Hexane  | 800             | 25                 |

**Table 4: SPIKE STANDARD AND SURROGATE STANDARD PREPARATION**

| Standard Name    | Stock Standard Conc. (mg/L) | Preparation  |                               |                 | Final Conc. (µg/L) |
|------------------|-----------------------------|--------------|-------------------------------|-----------------|--------------------|
|                  |                             | Aliquot (ml) | Solvent                       | Final Vol. (ml) |                    |
| PCB 1016         | 1000                        | 1.0          | 50% Isopropanol<br>50% Hexane | 100             | 10,000             |
| PCB 1260         | 1000                        | 1.0          | 50% Isopropanol<br>50% Hexane |                 |                    |
| PCT 5460         | 1000                        | 1.0          | 50% Isopropanol<br>50% Hexane | 100             | 10,000             |
| <b>Surrogate</b> |                             |              |                               |                 |                    |
| TCX              | 200                         | 2            | 50% Isopropanol<br>50% Hexane | 1000            | 400                |
| DCB              | 200                         | 2            | 50% Isopropanol<br>50% Hexane | 1000            | 400                |

**Table 5: COMPOUND LIST**

| Analytes |          | Surrogates           |
|----------|----------|----------------------|
| PCB 1016 | PCT 5432 | Decachlorobiphenyl   |
| PCB 1221 | PCT 5442 | Tetrachloro-m-xylene |
| PCB 1232 | PCT 5460 |                      |
| PCB 1242 |          |                      |
| PCB 1248 |          |                      |
| PCB 1254 |          |                      |
| PCB 1260 |          |                      |
| PCB 1262 |          |                      |
| PCB 1268 |          |                      |

**Table 6: ESTABLISHED LIMIT OF DETECTION (LOD) AND LIMIT OF QUANTITATION (LOQ)**

| ANALYTES             | AQUEOUS (µg/L) |       |       | SOIL (µg/Kg) |      |      |
|----------------------|----------------|-------|-------|--------------|------|------|
|                      | DL             | LOD   | LOQ   | DL           | LOD  | LOQ  |
| PCB 1016             | 0.45           | 0.45  | 0.45  | 13.2         | 16.7 | 33.3 |
| PCB 1221             | 0.29           | 0.29  | 0.29  | 8.3          | 16.7 | 33.3 |
| PCB 1232             | 0.25           | 0.25  | 0.25  | 9.0          | 16.7 | 33.3 |
| PCB 1242             | 0.25           | 0.25  | 0.25  | 9.3          | 16.7 | 33.3 |
| PCB 1248             | 0.25           | 0.25  | 0.25  | 8.3          | 16.7 | 33.3 |
| PCB 1254             | 0.25           | 0.25  | 0.25  | 8.3          | 16.7 | 33.3 |
| PCB 1260             | 0.31           | 0.31  | 0.31  | 9.9          | 16.7 | 33.3 |
| PCB 1262             | 0.25           | 0.25  | 0.25  | 8.3          | 16.7 | 33.3 |
| PCB 1268             | 0.25           | 0.25  | 0.25  | 8.3          | 16.7 | 33.3 |
| PCT 5432             | 0.5            | 0.5   | 0.5   | 10           | 20   | 40   |
| PCT 5442             | 0.5            | 0.5   | 0.5   | 10           | 20   | 40   |
| PCT 5460             | 0.5            | 0.5   | 0.5   | 10           | 20   | 40   |
| Tetrachloro-m-xylene | 0.020          | 0.020 | 0.020 | 0.42         | 0.83 | 1.67 |
| Decachlorobiphenyl   | 0.025          | 0.025 | 0.025 | 0.42         | 0.83 | 1.67 |

**Appendix 1:**

**SUMMARY OF QUALITY CONTROL PROCEDURES**

| QC PROCEDURE  | FREQUENCY  | ACCEPTANCE CRITERIA  | CORRECTIVE ACTION  | 1 <sup>st</sup> Rvw | 2 <sup>nd</sup> Rvw |
|---|--|--|--|---------------------|---------------------|
| Min. 5 Point Initial Calibration for PCB 1016 + 1260 and PCT 5460   | Initially, as needed   | RSD for all analytes ≤ 20%.<br>Linear – least squares regression<br>r ≥ 0.995.   | Correct then problem then repeat initial calibration.  |                     |                     |
| Second-source Calibration Verification for PCB 1016/1260 and PCT 5460   | Once per 5-point initial calibration                           | All analytes within ± 20% of expected value from the ICAL.   | Correct the problem. If problem persists, repeat initial calibration.  |                     |                     |
| Initial Calibration Verification Check for PCB 1016/1260 and PCT 5460   | Daily, before sample analysis                                  | All analytes within ± 20%  | Correct the problem. If problem persists, repeat initial calibration   |                     |                     |
| Calibration verification for PCB 1016/1260 and PCT 5460   | After every 12 hours and at the end of the analytical sequence | All analytes within ± 20% of expected value  | Correct the problem then repeat initial calibration verification and re-analyze all samples since last successful calibration verification.                                |                     |                     |
| Method Blank  | One per preparation batch (≤ 20 samples per matrix)            | No analytes detected > ½ LOQ or > 1/10 the amount measured in any sample or 1/10 the regulatory limit, whichever is greater. | Re-prep and re-analyze method blank and all samples processed with the contaminated blank  |                     |                     |
| LCS (PCB 1016/1260 and PCT 5460)  | One LCS per analytical batch (≤20 samples per matrix)          | Within project QC Limits   | Correct the problem, then re-prep and re-analyze the LCS and all associated samples.   |                     |                     |
| Surrogate Spike   | Every sample, spiked sample, standard, and method blank        | Within project QC Limits   | Correct the problem then re-extract and re-analyze sample  |                     |                     |
| Matrix Spike/ Matrix Spike Duplicate (PCB 1016/1260 and PCT 5460)   | One MS/MSD per 20 project samples per matrix                   | Within project QC Limits   | If chromatogram is indicative of matrix interference, discuss in case narrative. Otherwise, check for probable source of error and perform corrective action as necessary. |                     |                     |
| Confirmation  | 100% for all positive results                                  | Same as primary column   | If quantitation criteria are not met, use confirmation for qualitative identification only.  |                     |                     |
| Comments:<br>1. For flagging criteria refer to PSR. Otherwise, if MB is non-compliant, apply “B” to specific analyte(s) on all associated samples, apply “J” to all values between LOD and LOQ. |  |  |  | Reviewed By:        |                     |
|   |  |  |  | Date:               |                     |

Appendix 2:

DEMONSTRATION OF CAPABILITY

DEMONSTRATION OF CAPABILITY  
PCBs  
METHOD: EPA 8082/ 8082A

MATRIX: WATER

Analytical SOP: EMAX-8082 Rev. 4  
Sample Preparation SOP: EMAX-3520 Rev. 5  
Conc Unit: µg/L  
Sample Amount(mL): 1000  
Extract Volume (mL): 10

Instrument ID: 08  
Extraction batches: CPE002W - 5/5/14  
CPE009W - 5/7/14  
Extracted by: J. Muertigue  
Analysis date: 5/7/14 & 5/14/14  
Analyzed by: R. Zhou

| PARAMETER | 60E002WL | 60E002WC | 60E009WL | 60E009WC | TV  | Ave. Conc. | Ave. %Rec | SD    | RSD (%) | QC Criteria | COMMENTS |
|-----------|----------|----------|----------|----------|-----|------------|-----------|-------|---------|-------------|----------|
|           | SE07006A | SE07007A | SE12012A | SE12013A |     |            |           |       |         |             |          |
| PCB 1016  | 5.11     | 4.91     | 5.44     | 4.66     | 5   | 5.03       | 101       | 0.3   | 7       | 60 - 130    | PASSED   |
| PCB 1260  | 4.65     | 4.44     | 5.03     | 4.46     | 5   | 4.65       | 93        | 0.3   | 6       | 70 - 130    | PASSED   |
| PCT 5460  | 2.34     | 2.45     | 2.42     | 2.41     | 2.5 | 2.41       | 96        | 0.05  | 2       | 50 - 150    | PASSED   |
| TCX       | 0.396    | 0.385    | 0.399    | 0.391    | 0.4 | 0.393      | 98        | 0.006 | 2       | 60 - 130    | PASSED   |
| DCB       | 0.406    | 0.402    | 0.433    | 0.432    | 0.4 | 0.418      | 105       | 0.016 | 4       | 70 - 130    | PASSED   |

| PARAMETER | 60E002WL | 60E002WC | 60E009WL | 60E009WC | TV  | Ave. Conc. | Ave. %Rec | SD    | RSD (%) | QC Criteria | COMMENTS |
|-----------|----------|----------|----------|----------|-----|------------|-----------|-------|---------|-------------|----------|
|           | SE07006B | SE07007B | SE12012B | SE12013B |     |            |           |       |         |             |          |
| PCB 1016  | 5.02     | 4.83     | 4.86     | 4.69     | 5   | 4.85       | 97        | 0.1   | 3       | 60 - 130    | PASSED   |
| PCB 1260  | 4.70     | 4.68     | 4.86     | 4.76     | 5   | 4.75       | 95        | 0.1   | 2       | 70 - 130    | PASSED   |
| PCT 5460  | 2.17     | 2.28     | 2.16     | 2.14     | 2.5 | 2.19       | 88        | 0.1   | 3       | 50 - 150    | PASSED   |
| TCX       | 0.409    | 0.399    | 0.405    | 0.407    | 0.4 | 0.405      | 101       | 0.004 | 1       | 60 - 130    | PASSED   |
| DCB       | 0.372    | 0.367    | 0.389    | 0.384    | 0.4 | 0.378      | 95        | 0.010 | 3       | 70 - 130    | PASSED   |

MATRIX: SOIL

Analytical SOP: EMAX-8082 Rev. 4  
Sample Preparation SOP: EMAX-3550 Rev. 4  
Conc Unit: µg/Kg  
Sample Amount(g): 30  
Extract Volume (mL): 10

Instrument ID: 08  
Extraction batches: CPF0065 - 6/5/14  
CPF0185 - 6/10/14  
Extracted by: J. Villena  
Analysis date: 6/6/14 & 6/10/14  
Analyzed by: R. Zhou

| PARAMETER | 60F0065L | 60F0065C | 60F0185L | 60F0185C | TV   | Ave. Conc. | Ave. %Rec | SD    | RSD (%) | QC Criteria | COMMENTS |
|-----------|----------|----------|----------|----------|------|------------|-----------|-------|---------|-------------|----------|
|           | SF06006A | SF06007A | SF10006A | SF10007A |      |            |           |       |         |             |          |
| PCB 1016  | 181      | 171      | 163      | 163      | 167  | 169.56     | 102       | 8.5   | 5       | 70 - 130    | PASSED   |
| PCB 1260  | 159      | 154      | 156      | 155      | 167  | 155.63     | 93        | 2.2   | 1       | 70 - 140    | PASSED   |
| PCT 5460  | 76.5     | 77.4     | 84.3     | 82.9     | 83.3 | 80.29      | 96        | 3.9   | 5       | 50 - 150    | PASSED   |
| TCX       | 14.6     | 13.6     | 14.3     | 14.4     | 13.3 | 14.251     | 107       | 0.421 | 3       | 50 - 140    | PASSED   |
| DCB       | 14.2     | 14.1     | 14.9     | 14.8     | 13.3 | 14.508     | 109       | 0.446 | 3       | 70 - 140    | PASSED   |

| PARAMETER | 60F0065L | 60F0065C | 60F0185L | 60F0185C | TV   | Ave. Conc. | Ave. %Rec | SD    | RSD (%) | QC Criteria | COMMENTS |
|-----------|----------|----------|----------|----------|------|------------|-----------|-------|---------|-------------|----------|
|           | SF06006B | SF06007B | SF10006B | SF10007B |      |            |           |       |         |             |          |
| PCB 1016  | 190      | 184      | 164      | 170      | 167  | 176.93     | 106       | 12.0  | 7       | 70 - 130    | PASSED   |
| PCB 1260  | 161      | 159      | 168      | 168      | 167  | 164.13     | 98        | 4.7   | 3       | 70 - 140    | PASSED   |
| PCT 5460  | 71.8     | 73.2     | 77.5     | 76.8     | 83.3 | 74.84      | 90        | 2.8   | 4       | 50 - 150    | PASSED   |
| TCX       | 16.2     | 15.5     | 15.7     | 15.7     | 13.3 | 15.756     | 118       | 0.305 | 2       | 50 - 140    | PASSED   |
| DCB       | 12.2     | 12.1     | 13.4     | 13.2     | 13.3 | 12.733     | 95        | 0.657 | 5       | 70 - 140    | PASSED   |











**LABORATORIES, INC.**  
 1835 W. 205th Street  
 Torrance, CA 90501  
 Tel: (310) 618-8889  
 Fax: (310) 618-0818

ERRATUM TO

|                  |               |
|------------------|---------------|
| Document         | EMAX-8260     |
| Revision Number  | 10            |
| Section          | 5.1.3 & 5.1.4 |
| Date             | May 11, 2017  |
| Reference Number | 8260.10.1     |

Page 1 of 1

**Section 5.1.3 and 5.1.4 shall be revised as follows:**

- 5.1.3. Samples preserved with HCl to pH<2 must be analyzed within 14 days from the date of sampling. Samples that are not preserved with HCl or with pH≥2 must be analyzed within 7 days from the date of sampling.
- 5.1.4. If Acrolein and Acrylonitrile are target analytes, samples must be analyzed within 14 days if preserved with Na<sub>2</sub>S<sub>2</sub>O<sub>3</sub> to pH 4-5. Otherwise, analyze within 3 days from sampling date.

PREPARED BY:  Date: 05-11-17

Name Tu Nisamaneepong  
 Title Operations Manager

APPROVED BY:  Date: 05-11-17

Name Kenette Pimentel  
 Title QA Manager

APPROVED BY:  Date: 05-11-17

Name Caspar Pang  
 Title Laboratory Director



**LABORATORIES, INC.**  
1835 W. 205th Street  
Torrance, CA 90501  
Tel: (310) 618-8889

Page 1 of 1

ADDENDUM TO

|                  |                            |
|------------------|----------------------------|
| Document         | ALL ANALYTICAL SOPS        |
| Revision Number  | CURRENT REVISIONS          |
| Section          | 10.2 Instrument Parameters |
| Date             | 11 September 2019          |
| Reference Number | AA.7                       |

This applies to all GC/MS, GC, HPLC-MS, HPLC, ICP-MS, ICP and IC Method SOPs

Section 10.2 shall include:

**10.2. Instrument Parameters**

- 10.2.1. Instrument parameters setup stipulated in the SOPs, are instrument suggested parameters. Fine tune the instrument to obtain optimum instrument condition.
- 10.2.2. Print and staple a copy of the current instrument parameter on the instrument log for easy access when performing daily instrument routine check.
- 10.2.3. In the event that instrument parameters necessitate a change, replace the instrument parameter printout with the new parameter setup. Archive the previous instrument parameters at the back of the instrument maintenance log.

PREPARED BY:  Date: 9/11/19  
Name Farina Madamba  
Title QA / QC Coordinator

APPROVED BY:  Date: 09.11.19  
Name Kenette Pimentel  
Title QA Manager

APPROVED BY:  Date: 09-11-19  
Name Caspar Pang  
Title Laboratory Director

## STANDARD OPERATING PROCEDURES

VOLATILE ORGANICS BY GC/MS

SOP No.: EMAX-8260 Revision No. 10 Effective Date: 06-Jun-14

Prepared By: Souzan Greas *Souzan Greas* Date: 06-04-14

Approved By: Kenette Pimentel *KP* Date: 06.04.14  
QA Manager

Approved By: Caspar Pang *C Pang* Date: 06-04-14  
Laboratory Director

**Control Number: 8260-10-**

**1.0 SCOPE AND APPLICATION**

- 1.1. This analytical method is used to determine the concentration of volatile organic compounds whose boiling points are below 200°C and are water insoluble or slightly water-soluble found in solid or liquid samples. The list of compounds is summarized in Tables 6 and 7. Additional analytes may be added after verification.
- 1.2. This SOP is an adaptation of SW846 Method 8260B.

**2.0 SUMMARY OF METHOD**

- 2.1. A measured sample is extracted using a purge and trap concentrator system. The extract is introduced to a temperature-programmed GC. The analytes are eluted through the GC column separating each analyte relative to its volatility. These analytes are captured and ionized by the mass spectrometer. The ionized fragments are measured by mass to charge ratio. Analyte qualitative identification is based on the characteristic electron impact mass spectra. Analyte quantitative identification is based on the response of the major ion relative to an internal standard using a multi-point calibration curve.
- 2.2. **Interferences**
  - 2.2.1. Contamination may occur by diffusion of volatile organics (particularly chlorofluorocarbons and methylene chloride) through sample container septum during shipment and storage. Trip blanks and storage blanks can serve as means of monitoring.
  - 2.2.2. Glassware and other sample processing materials in which the samples come into contact with are possible sources of contamination. All glassware and other materials used must be purchased pre-cleaned or decontaminated prior to use.
  - 2.2.3. Solvents and reagents are possible sources of contamination. All solvents and reagents must be GC grade and must pass the QC checks prior to use.
  - 2.2.4. Contamination by carry-over can occur whenever high concentration samples are analyzed in sequence with a low concentration sample. To reduce potential carry-over, the concentrator must be thoroughly baked-out between samples and the sample syringe and purging device must be thoroughly rinsed with an appropriate solvent between samples.
  - 2.2.5. Another possible source of contamination is the analytical instrument itself. This can be monitored by analyzing an instrument blank prior to any analysis.

**3.0 DETECTION LIMITS**

- 3.1. **Detection Limit (DL), Limit of Detection (LOD) & Limit of Quantitation (LOQ)**

## STANDARD OPERATING PROCEDURES

**VOLATILE ORGANICS BY GC/MS**SOP No.: EMAX-8260 Revision No. 10 Effective Date: 06-Jun-14

---

- 3.1.1. Refer to EMAX-QA04 for generation, validation and verification for DL, LOD and LOQ.
- 3.1.2. Refer to Table 6 and Table 7 for established DL, LOD and LOQ levels.

**4.0 DYNAMIC RANGE**

- 4.1. The highest quantifiable concentration requiring no dilution is equal to the highest calibration point (see Sec. 9.4). All samples analyzed above this concentration are considered "over-range" and requires dilution to properly quantitate.
- 4.2. The concentration in the diluted sample should be at or above the project reporting limit. All diluted samples analyzed below this concentration are considered "under-range". A lower dilution factor is required to properly quantitate.
- 4.3. **Typical Dynamic Range**
  - 4.3.1. Water: 5 µg/L to 200 µg/L (5 ml purge)  
1 µg/L to 40 µg/L (25 ml purge)
  - 4.3.2. Soil: 5 µg/kg to 200 µg/kg

**5.0 SAMPLE HOLDING TIME & PRESERVATION****5.1. Aqueous Samples**

- 5.1.1. Samples received in the laboratory are expected to be contained in 40 ml vials with teflon lined septa with zero headspace.  
  
*Note: The size of any bubble caused by degassing upon cooling the sample must not exceed 6 mm.<sup>1</sup>*
- 5.1.2. Samples must be stored at ≤ 6°C without freezing.
- 5.1.3. Samples preserved in HCL must be analyzed within 14 days from the date of sampling. Samples with no chemical preservative must be analyzed within 7 days from the date of sampling.
- 5.1.4. If Acrolein and Acrylonitrile are target analytes, samples must be analyzed within 14 days if preserved with Na<sub>2</sub>S<sub>2</sub>O<sub>3</sub> to pH 4-5. Samples received unpreserved must be analyzed within 3 days from sampling date<sup>2</sup>.

**5.2. Soil Samples**

- 5.2.1. Samples received in glass jars or brass tubes must be stored at ≤ 6°C without freezing. Samples for low level and extracted in methanol for high level must be analyzed within 14 days from sampling date.
- 5.2.2. Samples received in encore tubes may be frozen, preserved with sodium bisulfate or extracted with methanol prior to analysis.

---

<sup>1</sup> Referenced from SW846 Method 5030B, Section 6.1.

<sup>2</sup> Reference: 40CFR Table 11 Footnote 10

## STANDARD OPERATING PROCEDURES

**VOLATILE ORGANICS BY GC/MS**SOP No.: EMAX-8260 Revision No. 10 Effective Date: 06-Jun-14

- Encore samples to be frozen must be analyzed within 14 days from sampling date.
- Encore samples to be preserved with sodium bisulfate for low level and extracted with methanol for high level must be done within 48 hours and analyzed within 14 days from sampling date.
- Preserved samples and extracts must be stored at  $\leq 6^{\circ}\text{C}$  without freezing.

**6.0 ASSOCIATED SOPs**

- 6.1. EMAX-5030 Purge and Trap
- 6.2. EMAX-5035 Closed-System Purge and Trap
- 6.3. EMAX-DM01 Data Flow and Review
- 6.4. EMAX-QA04 Detection Limit (DL)
- 6.5. EMAX-QA05 Training
- 6.6. EMAX-QA08 Corrective Action
- 6.7. EMAX-QC01 Quality Control for Chemicals
- 6.8. EMAX-QC02 Analytical Standard Preparation
- 6.9. EMAX-QC07 Glassware Cleaning
- 6.10. EMAX-SM01 Sample Management
- 6.11. EMAX-SM03 Waste Disposal
- 6.12. EMAX-SM04 Analytical and QC Sample Labeling

**7.0 SAFETY**

- 7.1. Read all SDS of chemicals listed in this SOP.
- 7.2. Treat all reagents, standards, and samples as potential hazards. Observe standard laboratory safety procedures. Wear protective gear, i.e., lab coat, safety glasses, and gloves at all times when performing this procedure. Perform all sample and standard handling in the fume hood.
- 7.3. If for any reason, solvent and/or other reagents get in contact with your skin or any other part of the body, rinse the affected body part thoroughly with copious amounts of water. If irritations or any other discomfort related to the incident persist, inform your supervisor immediately so that proper action can be taken.

**8.0 INSTRUMENTS, CHEMICALS & REAGENTS****8.1. Instruments and Supplies**

|                    |                                 |
|--------------------|---------------------------------|
| Gas Chromatography | HP 5890 Series II or equivalent |
| Detector           | HP 5971 MSD or equivalent       |

## STANDARD OPERATING PROCEDURES

**VOLATILE ORGANICS BY GC/MS**SOP No.: EMAX-8260 Revision No. 10 Effective Date: 06-Jun-14

|                           |   |
|---------------------------|---|
| Column                    | RTX 502.2 (0.32 mm x 60 m), 1.8 µm thickness or equivalent after verification that the four gases (chloromethane, bromomethane, chloroethane, and vinyl chloride) can be resolved > 90% from each other in the total ion chromatogram |
| Data Acquisition Software | ChemStation or equivalent   |
| Purge & Trap Device       | OI 4560/Encon Evolution/EST or equivalent   |
| Multiple purging module   | Archon/Centurion or equivalent  |
| Gases                     | Ultra-high purity helium/Air  |
| Syringes                  | 5 ml, 25 ml Luerlok gas-tight   |
| Microsyringes             | 1, 10, 20, 25, 50, 100 and 1000 µl<br>(Hamilton 702N or equivalent)   |
| Volumetric Flasks         | 2, 5, 10, 50 and 100 ml with ground glass stopper   |
| Heated Sparge             | Archon or Automatic sample heating jacket or equivalent   |

8.2. **Chemicals and Reagents**

|                    |   |
|--------------------|---|
| Extraction Solvent | Purge & Trap Grade Methanol or equivalent |
| Reagent Water      | Organic-free water                        |
| Reagent Soil       | Organic-free Ottawa Sand or equivalent    |
| Preservative       | Sodium Bisulfate                          |

9.0 **STANDARDS**

9.1. Standard preparation for VOA is summarized in Tables 1 to 4. Refer to EMAX-QC02 for proper analytical standard preparation and EMAX-SM04 for proper labeling. Other concentration levels may be prepared as long as it complies with the method and/or project requirements.

9.2. **Stock Standard**

- 9.2.1. Purchase Stock Standards as certified solutions.
- 9.2.2. Purchase one set of calibration standard (refer to Table 1) for calibration and a secondary source Stock Standard for calibration verification (refer to Table 2).
- 9.2.3. Purchase Surrogate Mix at 2500 mg/L and Internal Standard at 2500 mg/L (refer to Table 3).
- 9.2.4. Purchase BromoFluorobenzene (BFB) as Tuning Standard at 5000 mg/L (refer to Table 4).
- 9.2.5. After opening, transfer in inert vials with minimal headspace and store at -10°C to -20°C.

9.3. **Intermediate Standards**

- 9.3.1. Using the stock standard solutions, prepare intermediate standards in methanol according to Tables 1 to 4 and store with minimal headspace in an inert vial.

9.4. **Initial Calibration Standards (ICAL)**

## STANDARD OPERATING PROCEDURES

**VOLATILE ORGANICS BY GC/MS**SOP No.: EMAX-8260 Revision No. 10 Effective Date: 06-Jun-149.4.1. ICAL for 5 ml Purge

9.4.1.1. Using intermediate standards (refer to Tables 1 and 3), prepare multi calibration standards (minimum of five different concentrations) in reagent water as suggested below.

| Calibration Pt. | VOA (µg/L)* | Surrogate (µg/L) | Internal Std (µg/L) |
|-----------------|-------------|------------------|---------------------|
| 1               | 5           | 5                | 50                  |
| 2               | 10          | 10               | 50                  |
| 3               | 20          | 20               | 50                  |
| 4               | 50          | 50               | 50                  |
| 5               | 100         | 100              | 50                  |
| 6               | 200         | 200              | 50                  |

\* *Ketones, Acrolein, Acrylonitrile and tert-Butanol are 5X the indicated concentration and m/p-Xylene is 2x the indicated concentration.*

9.4.2. ICAL for 25 ml Purge

9.4.2.1. Using intermediate standards (refer to Tables 1 and 3), prepare multi calibration standards (minimum of five different concentrations) in reagent water as suggested below:

| Calibration Pt. | VOA (µg/L)* | Surrogate (µg/L) | Internal Std (µg/L) |
|-----------------|-------------|------------------|---------------------|
| 1               | 0.5         | 0.5              | 10                  |
| 2               | 1           | 1                | 10                  |
| 3               | 2           | 2                | 10                  |
| 4               | 10          | 10               | 10                  |
| 5               | 20          | 20               | 10                  |
| 6               | 40          | 40               | 10                  |

\* *Ketones, Acrolein, Acrylonitrile and tert-Butanol are 5X the indicated concentration and m/p-Xylene is 2x the indicated concentration.*

9.5. **Initial Calibration Verification Standard (ICV)**

9.5.1. Using the Intermediate Standard prepared from the secondary source (refer to Tables 2 and 3), spike into 5 ml or 25 ml purge in reagent water as suggested below.

9.5.1.1. ICV for 5 ml purge

| ICV  | VOA* (µg/L) | Surrogate (µg/L) | Internal Standard (µg/L) |
|------|-------------|------------------|--------------------------|
| 5 ml | 50          | 50               | 50                       |

\* *Ketones, Acrolein, Acrylonitrile and Tert-Butanol are 5x the indicated concentration and M/P-xylene is 2X the indicated concentration.*



## STANDARD OPERATING PROCEDURES

**VOLATILE ORGANICS BY GC/MS**SOP No.: EMAX-8260 Revision No. 10 Effective Date: 06-Jun-149.5.1.2. ICV for 25 ml purge

| ICV   | VOA*<br>(µg/L) | Surrogate<br>(µg/L) | Internal Standard<br>(µg/L) |
|-------|----------------|---------------------|-----------------------------|
| 25 ml | 10             | 10                  | 10                          |

*\* Ketones, Acrolein, Acrylonitrile and Tert-Butanol are 5x the indicated concentration and M/P-xylene is 2X the indicated concentration.*

9.6. **Daily Calibration Check Standard (DCC)**

9.6.1. Using the Intermediate Standard prepared from the same source as the ICAL Standard (refer to Tables 1 and 3), spike into 5 ml or 25 ml purge in reagent water as suggested below.

9.6.1.1. DCC for 5 ml purge

| DCC  | VOA*<br>(µg/L) | Surrogate<br>(µg/L) | Internal Standard<br>(µg/L) |
|------|----------------|---------------------|-----------------------------|
| 5 ml | 50             | 50                  | 50                          |

*\* Ketones, Acrolein, Acrylonitrile and Tert-Butanol are 5x the indicated concentration and M/P-xylene is 2X the indicated concentration.*

9.6.1.2. DCC for 25 ml purge

| DCC | VOA*<br>(µg/L) | Surrogate<br>(µg/L) | Internal Standard<br>(µg/L) |
|-----|----------------|---------------------|-----------------------------|
| 25  | 10             | 10                  | 10                          |

*\* Ketones, Acrolein, Acrylonitrile and Tert-Butanol are 5x the indicated concentration and M/P-xylene is 2X the indicated concentration.*

9.7. **LCS and Matrix Spike Standard**

9.7.1. For spike standards, use the Intermediate Standard prepared from the secondary source (refer to Tables 2 and 3), spike into the 5 ml or 25 ml purge sample as suggested below (unless otherwise specified by the project). Spike 5 ml or 25 ml reagent water for LCS water or 5 g reagent soil in 5 ml reagent water for LCS soil.

9.7.1.1. LCS and Matrix Spike for 5 ml purge

| LCS or MS/MSD | VOA*<br>(µg/L) | Surrogate<br>(µg/L) | Internal Standard<br>(µg/L) |
|---------------|----------------|---------------------|-----------------------------|
| 5 ml          | 50             | 50                  | 50                          |

*\* Ketones, Acrolein, Acrylonitrile and Tert-Butanol are 5x the indicated concentration and M/P-xylene is 2X the indicated concentration.*

## STANDARD OPERATING PROCEDURES

**VOLATILE ORGANICS BY GC/MS**SOP No.: EMAX-8260 Revision No. 10 Effective Date: 06-Jun-149.7.1.2. LCS and Matrix Spike for 25 ml purge

| LCS or MS/MSD | VOA*<br>(µg/L) | Surrogate<br>(µg/L) | Internal Standard<br>(µg/L) |
|---------------|----------------|---------------------|-----------------------------|
| 25 ml         | 10             | 10                  | 10                          |

*\* Ketones, Acrolein, Acrylonitrile and Tert-Butanol are 5x the indicated concentration and M/P-xylene is 2X the indicated concentration.*

**10.0 PROCEDURES****10.1. Sample Preparation**

10.1.1. For aqueous samples, refer to EMAX-5030.

10.1.1.1. Check the pH and presence of residual chlorine from remaining sample. Record samples with pH  $\geq 2$  and residual chlorine  $\geq 5$  mg/L in the analysis log.

10.1.2. For soil samples, refer to EMAX-5035.

**10.2. Instrument Parameters**

10.2.1. From the main gas supply (gas Tanks) regulate gas pressure at 80 psi.

10.1.1. Fine-tune the instrument guided by the parameter conditions suggested below. Adjust the parameter conditions accordingly to obtain optimum condition. Print the instrument parameter and post it on the instrument for daily routine maintenance check.

10.2.2. Typical GC Parameters

|                                  |  |
|----------------------------------|--|
| Carrier gas flow (column) helium | 1 – 5 ml/min                           |
| Initial Temp                     | 35°C; hold for 1 min.                  |
| Rate 1                           | 8°C/min. to 160°C/min                  |
| Rate 2                           | 30°C/min to 230°C/min; hold for 3 min. |
| Inject Port                      | 200°C                                  |
| Interface                        | 250°C                                  |

10.2.3. Mass Spectrometer Parameter

|            |              |
|------------|--------------|
| Scan Start | 0.5 min.     |
| Mass Range | 35 to 300    |
| Multiplier | 1200 to 2700 |

10.2.4. Typical Purge and Trap Condition

10.2.4.1. Purge samples at 40°C for 11 minutes, desorbed at 250°C for 2 minutes and then bake the trap at 260°C for 11 minutes.

**10.3. Calibration**

10.3.1. Set GC/MS operating condition as described in Section 10.2.

## STANDARD OPERATING PROCEDURES

**VOLATILE ORGANICS BY GC/MS**SOP No.: EMAX-8260 Revision No. 10 Effective Date: 06-Jun-14

---

10.3.2. Perform Tune Check

- 10.3.2.1. Introduce a BFB to yield 5 – 50 ng by either direct injection or purge and trap in 5 ml or 25 ml organic-free water (using tuning standard). Refer to table 4.
- 10.3.2.2. Evaluate the tune check by the highest scan on the peak or the average of at least 3 scans (before, at and after the apex) with a background subtraction using a single scan no more than 20 scans prior to the elution of BFB.
- 10.3.2.3. Check Table 5 for acceptance criteria or follow the manufacturer's recommendation for tuning. A valid tune check expires after 12 hours.
- 10.3.2.4. If non-compliant refer to Section 12 for corrective action.

10.3.3. Initial Calibration (ICAL)

- 10.3.3.1. Perform ICAL when one of the conditions occurs.
  - Instrument is new
  - Instrument undergoes a major repair
  - DCC failed to meet the acceptance criteria
- 10.3.3.2. Optimize the instrument condition prior to ICAL
  - Ensure that instrument parameters are set up properly
  - Ensure that there is no evidence of leak
  - Ensure that instrument maintenance is performed on schedule
  - Ensure that instrument tune check and column performance is not indicative that it is at the threshold of failing the acceptance criteria
- 10.3.3.3. Analyze a multi-point initial calibration curve as suggested in Figure 3 after a valid tune check.
- 10.3.3.4. Base quantitation of identified compounds on the integrated abundance from the EICP of the assigned primary characteristic ion (refer to Tables 6 and 7). For optimum output, assign internal standard to each compound based on the nearest retention time or as suggested on Tables (6 and 7).
- 10.3.3.5. Evaluate the ICAL Acceptance
  - 10.3.3.5.1. Check for completeness of target compound list. If there is/are missing compound(s), perform the following:
    - Check the established retention time window
    - Check the relative intensity of major ions
    - Adjust accordingly if necessary
  - 10.3.3.5.2. Evaluate retention time of each analyte with respect to the nearest internal standard. The relative retention time (RRT) of each analyte should agree within  $\pm 0.06$  RRT units.

## STANDARD OPERATING PROCEDURES

**VOLATILE ORGANICS BY GC/MS**SOP No.: EMAX-8260 Revision No. 10 Effective Date: 06-Jun-14

---

10.3.3.5.3. At a minimum, evaluate System Performance Check Compounds (SPCC) and Calibration Check Compounds (CCC) as specified in Appendix 1.

10.3.3.5.4. Check RSD and correlation coefficient. If more than 10% of the compounds included with the initial calibration exceed the 15% RSD limit and do not meet the minimum correlation coefficient (0.99) for alternate curve fits, then the chromatographic system is considered too reactive for analysis to begin. Perform necessary instrument maintenance and repeat calibration. Refer to 10.3.3.2, Section 12 for corrective action.

10.3.3.6. Application of ICAL Curve for Quantitation

10.3.3.6.1. Generate a summary of Relative Response Factors for each analyte at each concentration. Calculate the Average Relative Response Factor (RRFm), the Standard Deviation (SD), and the Relative Standard Deviation (RSD) according to Eq.-10.5.1.1, Eq.-10.5.1.2, Eq.-10.5.1.6 and Eq.-10.5.1.7 respectively.

10.3.3.6.2. If RSD is  $\leq 15\%$  average response factor may be applied.

10.3.3.6.3. Apply Inverse Weighting Factor ( $1/y$  or  $1/y^2$ ;  $y$  being the instrument response) if it is determined to be the best fit for specific analytes. This approach may be applied to any analyte including analyte that has RSD of  $\leq 15\%$  and correlation coefficient of  $\geq 0.995$ .

10.3.3.6.4. Apply linear least squares regression if past experience or priori knowledge of instrument response is known to be the best fit for specific analytes. This approach may be applied to any analyte including analyte that has RSD of  $\leq 15\%$  and correlation coefficient of  $\geq 0.995$ .

10.3.3.6.5. It may be appropriate to force the regression through zero for specific analytes<sup>3</sup>. When exercising this option [as included in the data acquisition software], make sure that the origin (0,0) is not included as a calibration point but rather the intercept is set to zero. This option shall only be applied if the curve favors better accuracy of quantitation.

10.3.3.7. Submit summary of ICAL, raw data and manual integration (if any) for secondary review.

10.3.4. Initial Calibration Verification (ICV)

10.3.4.1. Analyze ICV to verify the concentration of the ICAL standards (refer to Section 9.5).

10.3.4.2. Check for completeness of analytes as described in Section 10.4.3.

10.3.4.3. Compare the retention times of the internal standards to the ICAL mid-point. Excursion of  $\pm 30$  seconds indicates instrument malfunction. When non-compliant check the column head pressure, gas supply or leaks. Corrective action is required prior to further analysis.

10.3.4.4. Compare the area of the Internal Standards (IS) acquired against the midpoint of the initial calibration point. The extracted ion current profile (EICP) must be within a factor of two ( $-50\%$  to  $+100\%$ ).

---

<sup>3</sup> SW846 Method 8000B, Section 7.5.3

## STANDARD OPERATING PROCEDURES

**VOLATILE ORGANICS BY GC/MS**SOP No.: EMAX-8260 Revision No. 10 Effective Date: 06-Jun-14

---

10.3.4.5. Refer to Appendix 1 for ICV acceptance criteria and/or corrective action.

10.3.4.6. When non-compliant refer to Section 12 for corrective action.

10.3.5. Daily Continuing Calibration (DCC)

10.3.5.1. Analyze DCC to check the validity of the ICAL (refer to 9.6).

10.3.5.2. Check for completeness of analytes as described in Section 10.4.3.

10.3.5.3. Evaluate System Performance Check Compounds (SPCC) and Calibration Check Compounds (CCC) as specified in Appendix 1.

10.3.5.4. Compare the retention times of the internal standards to the ICAL mid-point. Excursion of  $\pm 30$  seconds indicates instrument malfunction. When non-compliant check the column head pressure, gas supply or leaks. Corrective action is required prior to further analysis.

10.3.5.5. Compare the area of the Internal Standards (IS) acquired against the midpoint of the initial calibration point. The extracted ion current profile (EICP) must be within a factor of two (-50% to +100%).

10.3.5.6. Establish RRF of each analyte, calculate %D (Eq.-10.5.2.1) against the ICAL.

10.3.5.7. Refer to Appendix 1 for DCC acceptance criteria and/or corrective action.

10.3.5.8. When non-compliant refer to Section 12 for corrective action.

**10.4. Analysis**

10.4.1. Analytical Sequence

10.4.1.1. Analyze BFB and evaluate tuning

10.4.1.2. Analyze DCC and check ICAL validity

10.4.1.3. Analyze Lab Control Sample

10.4.1.4. Analyze Lab Control Sample Duplicate (if required)

10.4.1.5. Analyze Method Blank

10.4.1.6. Analyze samples to a maximum number of 12-hours from the time of BFB injection.

10.4.1.7. Analyze a pair of matrix spikes (MS/MSD) for every 20 samples of the same matrix.

10.4.1.8. Record analytical sequence in the analysis log.

10.4.2. Sample Result Evaluation

10.4.2.1. Check the QC criteria as soon as the data is available.

✓ Check method blank. If result is non-compliant and analyte in question is not detected in any sample or contamination is  $< 10X$  of the sample concentration, results maybe reportable. Verify with the PM if results can be reported.

✓ Compare the retention times of each Internal Standards (IS) to the ICAL mid point (must be  $\pm 30$  seconds).

## STANDARD OPERATING PROCEDURES

**VOLATILE ORGANICS BY GC/MS**SOP No.: EMAX-8260 Revision No. 10 Effective Date: 06-Jun-14

- ✓ Compare the area of each IS acquired against the mid point of the ICAL. The Extracted Ion Current Profile (EICP) must be within a factor of two (-50 to +100%).
- ✓ Check concentration of target analytes if calibration range is exceeded.
- ✓ Check surrogate recoveries against project specific requirement (PSR). In the absence of PSR, default to Appendix 1 QC limits.
- ✓ If any of the above checkpoints indicate a problem, re-analysis is required. Note observations on the analysis log. When results arise to questionable result, e.g. inconsistency from the first analysis, consult the Supervisor for further action.

10.4.2.2. Properly fill up the analysis log.

10.4.3. Qualitative Identification

- The intensities of the characteristic ions maximize in the same scan or within one scan of each other.
- The relative retention time (RRT) of the sample component is within 0.06 RRT units of the RRT of the standard component.
- The relative intensity of the characteristic ions agrees within 30% of the relative intensity of these ions in the reference spectrum.
- Check the chromatogram for possible misidentified analytes. Investigate visible peaks in the chromatogram that were not identified in the data output. Manually integrate the peak if necessary. For manual integration refer to EMAX-DM01.
- Structural isomers that produce very similar mass spectra should be identified as individual isomers if they have sufficiently different GC retention times. Sufficient GC resolution is achieved if the height of the valley between two isomer peaks is less than 25% of the sum of the two peak heights. Otherwise, structural isomers are identified as isomeric pairs.<sup>4</sup>

10.4.3.1. For samples containing components not associated with the calibration standards, perform a library search for purposes of tentative identification<sup>5</sup> (TIC). Execute LSC (Chem Station program) to initiate the library search using NIST/EPA/MSDC mass spectral library. Visually inspect each extracted mass ion chromatograph to determine the identification of the unknown before final reporting following the guidelines below.

- Relative intensities of major ions in the reference spectrum (ions greater than 10% of the most abundant ion) should be present in the sample spectrum.
- The relative intensities of the major ions should agree within + 20%. Example: for an ion with an abundance of 50% of the standard spectra, the corresponding sample ion abundance must be between 30 and 70%.

<sup>4</sup> SW846 Method 8260B, Section 7.6.1.4

<sup>5</sup> Library search is performed only when indicated in the PSR.

## STANDARD OPERATING PROCEDURES

**VOLATILE ORGANICS BY GC/MS**SOP No.: EMAX-8260 Revision No. 10 Effective Date: 06-Jun-14

---

- Molecular ions present in reference spectrum should be present in sample spectrum.
- Ions present in the sample spectrum but not in the reference spectrum should be reviewed for possible background contamination or presence of co-eluting analytes.
- Ions present in the reference spectrum but not present in the sample spectrum should be reviewed for possible subtraction from the sample spectrum because of background contamination or co-eluting analytes. Data system library reduction programs can sometimes create these discrepancies.

**10.4.3.2. Reporting TICs**

- If the library search produces a match at or above 85%, report the analyte.
- If the library search produces more than one analyte at or above 85%, report the first analyte (highest).
- If the library search produces no matches at or above 85%, the compound should be reported as unknown.

**10.4.4. Quantitation**

10.4.4.1. Apply the appropriate quantitation method (Section 10.3.3.6). Calculate the concentration of any positively identified target analyte using Eq.-10.5.3. Apply the dilution factor for diluted samples to calculate for the final concentration of the sample.

**10.4.5. Manual Integration**

10.4.5.1. Refer to EMAX-DM01, Manual Integration Section.

**10.4.6. Dealing with Carryover**

10.4.6.1. Check the sample analyzed after a sample having target analyte concentrations exceeding the calibration range.

10.4.6.2. If there is no target analyte detected as found in the sample that exceeded the calibration range, proceed with data reduction.

10.4.6.3. If there is any target analyte detected as found in the sample that exceeded the calibration range, re-analyze the sample to rule out carry over. If carry over is confirmed, proceed with data reduction and report the data from re-analysis.

10.4.6.4. To clean-up the autosampler purge line consider purging a 25 ml or 5 ml sample spiked with 100  $\mu$ l of methanol and let it run like a blank sample. If improved result is noted repeat this process until no evidence of contamination is observed. Otherwise inform the Supervisor for further instruction.

**10.5. Calculations****10.5.1. Initial Calibration****10.5.1.1. Calculate for the Relative Response Factor (RRF)**

## STANDARD OPERATING PROCEDURES

**VOLATILE ORGANICS BY GC/MS**SOP No.: EMAX-8260 Revision No. 10 Effective Date: 06-Jun-14

$$RRF = \frac{A_X C_{IS}}{A_{IS} C_X} \quad \text{Eq.-10.5.1.1}$$

where:

- $A_X$  – Area of characteristic ion for the compound being measured  
 $A_{IS}$  – Area of characteristic ion for the specific internal standard  
 $C_X$  – Concentration of the compound being measured  
 $C_{IS}$  – Concentration of the specific internal standard

**10.5.1.2. Calculate for the Average Relative Response Factor (RRF<sub>m</sub>)**

$$RRF_m = \frac{\sum RRF}{n} \quad \text{Eq.-10.5.1.2}$$

where:

- $\sum RRF$  – Summation of response factors  
 $n$  – Number of measurements

**10.5.1.3. Calculate for Least Square Linear Regression**

$$y = ax + b \quad \text{Eq.-10.5.1.3}$$

where:

- $y$  – Response ratio ( $A_X/A_{IS}$ )  
 $x$  – Amount ratio ( $C_X/C_{IS}$ )  
 $a$  – x1 = slope of the line  

$$a = \frac{\sum (x - \bar{x})(y - \bar{y})}{\sum (x - \bar{x})^2}$$

where:

- $\bar{x}$  = average of amount ratios  
 $\bar{y}$  = average of response ratios  
 $b$  – x0 = intercept of the line  

$$b = \bar{y} - a * \bar{x}$$

**10.5.1.4. Calculate for Inverse Weighting Factor**

$$y = ax + b \quad \text{Eq.-10.5.1.4}$$

where:

- $y$  – Response ratio ( $A_X/A_{IS}$ )  
 $x$  – Amount ratio ( $C_X/C_{IS}$ )  
 $a$  – x1 = slope of the line  

$$a = \frac{\sum (x - x_a)(y - y_a)}{\sum (x - x_a)^2}$$

where:

$$x_a = \sum [x(1/x) / \sum (1/x)]$$

$$y_a = \sum [y(1/x) / \sum (1/x)]$$



## STANDARD OPERATING PROCEDURES

VOLATILE ORGANICS BY GC/MSSOP No.: EMAX-8260 Revision No. 10 Effective Date: 06-Jun-14

$$\text{or } x_a = \frac{\sum [x(1/x^2)]}{\sum (1/x^2)}$$

$$y_a = \frac{\sum [y(1/x^2)]}{\sum (1/x^2)}$$

$$b - x_0 = \text{intercept of the line}$$

$$b = y_a - a * x_a$$

## 10.5.1.5. Calculate Inverse Quadratic

$$y = ax^2 + bx + c$$

where:

$$y - \text{Resp\_Ratio} = x_0 + x_1 * \text{Amt\_Ratio} + x_2 * (\text{Amt\_Ratio})^2$$

$$x - \text{Amt\_Ratio}$$

$$c - x_0 = \text{Det } 0 / \text{Det } b$$

$$b - x_1 = \text{Det } 1 / \text{Det } b$$

$$a - x_2 = \text{Det } 2 / \text{Det } b$$

$$W_i = \frac{\frac{1}{x_i}}{\sum_{i=1}^n \frac{1}{x_i}}$$

where:

$$X_i = \text{amount ratio} = \text{Conc of Std} / \text{Conc of IS}$$

$$Y_i = \text{response ratio} = \text{Resp of Std} / \text{Resp of IS}$$

$$W_i = 1/X_i / \text{SUM}(1/X_i)$$

$$\langle X \rangle = \text{SUM}(W_i * X_i)$$

$$\langle Y \rangle = \text{SUM}(W_i * Y_i)$$

$$\langle XX \rangle = \text{SUM}(W_i * (X_i)^2)$$

$$\langle XXX \rangle = \text{SUM}(W_i * (X_i)^3)$$

$$\langle XXXX \rangle = \text{SUM}(W_i * (X_i)^4)$$

$$\langle YY \rangle = \text{SUM}(W_i * (Y_i)^2)$$

$$\langle XY \rangle = \text{SUM}(W_i * X_i * Y_i)$$

$$\langle XXY \rangle = \text{SUM}(W_i * (X_i)^2 * Y_i)$$

$$\langle Yd2 \rangle = \text{SUM}((Y_i - \langle Y \rangle)^2 * W_i)$$

$$Ye = x_0 + x_1 * X_i + x_2 * X_i^2 - \langle Y \rangle$$

$$\langle Ye2 \rangle = \text{SUM}(Ye^2 * W_i)$$

## STANDARD OPERATING PROCEDURES

**VOLATILE ORGANICS BY GC/MS**SOP No.: EMAX-8260 Revision No. 10 Effective Date: 06-Jun-14

|       |      |       |        |
|-------|------|-------|--------|
| Det b | 1    | <X>   | <XX>   |
|       | <X>  | <XX>  | <XXX>  |
|       | <XX> | <XXX> | <XXXX> |

|       |     |      |       |
|-------|-----|------|-------|
| Det 0 | 1   | <X>  | <XX>  |
|       | <X> | <XX> | <XXX> |
|       | <Y> | <XY> | <XXY> |

|       |      |       |        |
|-------|------|-------|--------|
| Det 1 | 1    | <X>   | <XX>   |
|       | <Y>  | <XY>  | <XXY>  |
|       | <XX> | <XXX> | <XXXX> |

|       |      |       |        |
|-------|------|-------|--------|
| Det 2 | <Y>  | <XY>  | <XXY>  |
|       | <X>  | <XX>  | <XXX>  |
|       | <XX> | <XXX> | <XXXX> |

$$r^2 = \frac{<Ye2>}{<Yd2>}$$

$$ccf2 = (r^2)^{1/2}$$

## 10.5.1.6. Calculate the Standard Deviation (SD)

$$SD = \sqrt{\frac{\sum_{i=1}^n (x_i - \bar{x})^2}{n-1}} \quad \text{Eq.-10.5.1.6}$$

where:

- $x_i$  – Result at  $i^{\text{th}}$  measurement
- $\bar{x}$  – Mean of the  $n$  measurements
- $n$  – Number of measurements

## 10.5.1.7. Calculate the % relative standard deviation (%RSD)

$$\%RSD = \frac{SD}{RRF_m} * 100\% \quad \text{Eq.-10.5.1.7}$$

where:

- $SD$  – Standard deviation
- $RRF_m$  – Average response factor

## 10.5.1.8. Calculate the relative retention time (RRT)

$$RRT = \frac{\text{Retention Time of the Analyte}}{\text{Retention Time of the Internal Standard}} \quad \text{Eq.-10.5.1.8}$$

10.5.2. Calibration Check/Continuing Calibration

## STANDARD OPERATING PROCEDURES

**VOLATILE ORGANICS BY GC/MS**SOP No.: EMAX-8260 Revision No. 10 Effective Date: 06-Jun-1410.5.2.1. **Calculate Percent Difference (%D)**

$$\%D = \frac{[RRF_c - RRF_m]}{RRF_m} * 100\% \quad \text{Eq.-10.5.2.1}$$

where:

- $RRF_c$  – Response factor from continuing calibration standard  
 $RRF_m$  – Average response factor

10.5.2.2. **% Drift**

$$\%Drift = \frac{[found\ Conc. - true\ Conc.]}{true\ Conc.} * 100\% \quad \text{Eq.-10.5.2.2}$$

10.5.3. **Calculation of Sample Concentration (Water and Soil/Sediment Samples)**

10.5.3.1. When a compound is identified, the quantitation of that compound shall be based on the integrated abundance from the EICP of the primary characteristic ion.

10.5.3.2. **Water Samples**

$$Concentration\ (ug/L) = \frac{(A_x)(I_s)}{(A_{is})(RRF_m)} \times DF \quad \text{Eq.-10.5.3.2}$$

where:

- $A_x$  – Area of characteristic ion for the compound to be measured  
 $I_s$  – Concentration of internal standard added in  $\mu\text{g/L}$   
 $A_{is}$  – Area of characteristic ion for the internal standard  
 $RRF_m$  – Average response factor  
 $DF$  – Dilution factor =  $\frac{\text{purge volume in ml (5 ml or 25 ml)}}{\text{sample amount in ml}}$

10.5.3.3. **Soil/Sediment Samples (Dry weight basis)**

$$Concentration\ (ug/kg) = \frac{(A_x)(I_s)}{(A_{is})(RRF_m)(DW)} \times DF \quad \text{Eq.-10.5.3.3}$$

where:

- $A_x$  – Area of characteristic ion for the compound to be measured  
 $I_s$  – Concentration of internal standard added in  $\mu\text{g/L}$   
 $A_{is}$  – Area of characteristic ion for the internal standard  
 $RRF_m$  – Average response factor  
 $DF$  – Dilution factor =  $\frac{5\ \text{g}}{(\text{sample amount in g})}$   
 $DW$  – % solid =  $\frac{100 - \%moisture}{100}$

10.5.3.4. **Extracted Soil/Sediment Samples (Dry weight basis)**

$$Concentration\ (ug/kg) = \frac{(A_x)(I_s)}{(A_{is})(RRF_m)(DW)} \times DF \quad \text{Eq.-10.5.3.4}$$

where:

- $A_x$  – Area of characteristic ion for the compound to be measured

## STANDARD OPERATING PROCEDURES

**VOLATILE ORGANICS BY GC/MS**SOP No.: EMAX-8260 Revision No. 10 Effective Date: 06-Jun-14

$$\begin{aligned}
 I_s & - \text{Concentration of internal standard added in } \mu\text{g/L} \\
 A_{is} & - \text{Area of characteristic ion for the internal standard} \\
 RRF_m & - \text{Average response factor} \\
 DF & - \text{Dilution factor} \\
 DW & - \text{\% solid} = \frac{(purged \text{ volume in } \mu\text{L})(5 \text{ g})}{(extract \text{ aliquot in } \mu\text{L})(sample \text{ amount in g})} \\
 & - \text{\% solid} = \frac{100 - \%moisture}{100}
 \end{aligned}$$

10.5.4. Alternatively, the regression line (area ratio of  $A_x/A_{is}$  versus concentration using first degree) fitted to the initial calibration may be used for determination of the sample concentration when RSD of the analyte is greater than 15% (Section 10.3.3.6) .

10.5.5. Concentration of TIC is estimated by the same method as target compounds with the following assumptions:

10.5.5.1. The area  $A_x$  and  $A_{is}$  are derived from total ion chromatogram.  $A_{is}$  refers to the closest internal standard (IS) free of interference.

10.5.5.2. RRF of the TIC is 1.

10.5.6. Method Proficiency

10.5.6.1. **Percent Recovery**

$$\% \text{ Recovery} = \frac{(C_f - C)}{C_s} \times 100 \quad \text{Eq.-10.5.6.1}$$

where:

$C_f$  - Concentration found

$C$  - Concentration of sample (use 0 for LCS)

$C_s$  - Concentration of spike

10.5.6.2. **Relative Percent Difference (RPD)**

$$RPD = \frac{|C_1 - C_2|}{\left(\frac{C_1 + C_2}{2}\right)} \times 100 \quad \text{Eq.-10.5.6.2}$$

where:

$C_1$  - Measured concentration of the first sample aliquot

$C_2$  - Measured concentration of the second sample aliquot

10.6. **Data Reduction**

10.6.1. Make a copy of the analysis log.

10.6.2. Print a copy of the sample weight log (if any).

10.6.3. Highlight the data to be reported.

## STANDARD OPERATING PROCEDURES

**VOLATILE ORGANICS BY GC/MS**SOP No.: EMAX-8260 Revision No. 10 Effective Date: 06-Jun-14

---

- 10.6.4. Print a copy of the raw data and the QC report.
- 10.6.5. Collate the reportable raw data separating the QC results from the sample results.
- 10.6.6. Keep all other data generated with the analytical folder marked with "For record only".

**10.7. Report Generation**

- 10.7.1. Generate the method.txt file using WDB1C.exe.
- 10.7.2. Generate the sample results using F1NV3C.exe or F1NV3C4.exe.
- 10.7.3. Generate the QC summary using QCV3CN.exe or QCV3CN4.exe.
- 10.7.4. Generate the Instrument Performance Check (ICAL and DCC) using F5VOA.exe.
- 10.7.5. Generate the IS and RT summary using F8VC.exe.
- 10.7.6. Generate Lab Chronicle using LABCHRN1.exe
- 10.7.7. Generate Case Narrative using CN1.exe
- 10.7.8. Arrange the analysis package in sequence as detailed below using section separators. Attach all raw data to every form generated, to include manual integration and re-analyses.
  - 10.7.8.1. Case Narrative
  - 10.7.8.2. Lab Chronicle
  - 10.7.8.3. Sample Results
  - 10.7.8.4. Method Blank Results
  - 10.7.8.5. LCS/LCSD Summary
  - 10.7.8.6. MS/MSD Summary
  - 10.7.8.7. Instrument Performance Check (ICAL)
  - 10.7.8.8. ICAL Summary
  - 10.7.8.9. ICV Summary
  - 10.7.8.10. Instrument Performance Check (DCC)
  - 10.7.8.11. IS and RT Summary
  - 10.7.8.12. DCC Summary
  - 10.7.8.13. Analysis Log
  - 10.7.8.14. Sample Weight Log (if any)
  - 10.7.8.15. Non-Conformance Report (If any)

**10.8. Data Review**

- 10.8.1. Perform a 100% data review in accordance to EMAX-DM01 and the PSR.
  - 10.8.1.1. If any of the checkpoints below indicates a problem, re-analysis is required.
    - ✓ Check internal standard area. They should be within -50 to +100% of ICAL midpoint to be acceptable, otherwise follow PSR.

## STANDARD OPERATING PROCEDURES

**VOLATILE ORGANICS BY GC/MS**SOP No.: EMAX-8260 Revision No. 10 Effective Date: 06-Jun-14

- ✓ Check retention time of each IS to the ICAL midpoint. They should be within  $\pm 30$  seconds to be acceptable, otherwise follow PSR.
- ✓ Check surrogate recoveries against project specific criteria (PSR). In the absence of PSR, default to in-house QC limits.
- ✓ Check concentration of target analytes if calibration range is exceeded.

10.8.1.2. Review the attached logs that they are properly filled.

10.8.1.3. Check the generated reports against the raw data. Check that the analytical data generated indicating positive results are qualitatively and quantitatively correct.

10.8.1.4. Review the case narrative and check that it accurately describes what transpired in the analytical process. Edit as necessary to reflect essential issues not captured by the case narrative generator program.

10.8.2. Submit the analytical folder for secondary review.

#### 10.9. Preventive Maintenance

10.9.1. Perform instrument routine preventive maintenance and record on instrument-specific maintenance logs. Routine maintenance ensures that all equipment is operating under optimum conditions, thus reducing the possibility of instrument malfunction that may affect data quality.

10.9.2. The table below list suggested routine maintenance schedule.

| Task   | Every Day | Every Week | Every Month | Every 3 Months | Every 6 Months | As Needed |
|--|-----------|------------|-------------|----------------|----------------|-----------|
| Tune Check   | ✓         |            |             |                |                |           |
| Check gas cylinders pressure   | ✓         |            |             |                |                |           |
| Check the foreline pump oil level  |           | ✓          |             |                |                |           |
| Check the calibration vial   |           |            |             |                |                | ✓         |
| Check and if necessary, change injection port liners, septa and O-rings. |           |            |             |                | ✓              |           |
| Replace the foreline pump oil  |           |            |             |                | ✓              |           |
| Replace the diffusion pump fluid   |           |            |             |                | ✓              |           |
| Replace the traps and filters  |           |            |             |                | ✓              |           |
| Clean the ion source   |           |            |             |                |                | ✓         |
| Change the carrier gas trap(s) and purifier                              |           |            |             |                |                | ✓         |
| Replace column   |           |            |             |                |                | ✓         |
| AutoTune the MSD   |           |            |             |                |                | ✓         |
| Replace the worn out parts   |           |            |             |                |                | ✓         |

## STANDARD OPERATING PROCEDURES

**VOLATILE ORGANICS BY GC/MS**SOP No.: EMAX-8260 Revision No. 10 Effective Date: 06-Jun-14

---

**11.0 QUALITY CONTROL****11.1. Analytical Batch QC**

- 11.1.1. Perform tune check to verify that the mass spectrometer meets standard mass spectra abundance criteria prior to calibration and check for any contamination.
- 11.1.2. Perform initial calibration (ICAL) to establish a calibration curve for the quantification of the analytes of interest.
- 11.1.3. Establish retention time window position for each analyte every after ICAL for proper qualitative identification.
- 11.1.4. Perform initial continuing calibration verification (ICV) every after ICAL to verify accuracy of ICAL.
- 11.1.5. Perform continuing calibration verification (CCV) every 12 hours to verify that instrument response is reliable, and has not changed significantly from the current ICAL curve.
- 11.1.6. Evaluate relative retention time for each analytes in every sample to be within  $\pm 0.06$  RRT units.
- 11.1.7. Verify internal standard (IS) for quantitative accuracy and that its Retention time is within  $\pm 30$  seconds from retention time of the midpoint standard in the ICAL and EICP area is within -50% to +100% of ICAL midpoint standard.
- 11.1.8. Evaluate surrogate recovery to monitor instrument response on every sample.

**11.2. Preparation Batch QC**

- 11.2.1. Reagent water used for IB shall be of the same source for all QC samples and sample dilutions.
- 11.2.2. Analyze MB, LCS, MS/MSD and < 20 field samples.
- 11.2.3. Solvents and reagents must undergo quality control check prior to its use. Refer to EMAX-QC01 for details.
- 11.2.4. Properly treat lab wares used in the sample preparation as specified in EMAX-QC07.

**11.3. Method QC**

- 11.3.1. All analytes reported must have a valid DL, LOD and LOQ as described in EMAX-QA04.
  - 11.3.2. All analysts conducting this analysis must demonstrate capability (IDOC/DOC) as described in EMAX-QA05.
- 11.4. Refer to Appendix 1 for all related Quality Control parameters, frequency and acceptance criteria.

**12.0 CORRECTIVE ACTION**

12.1. Corrective action for each Quality Control procedure is summarized in Appendix 1.

**12.2. Analytical Batch QC**

- 12.2.1. Tune Check – If tune check is non-compliant consider the following suggestion to correct the problem:
  - Check the abundance of mass 95 and 174. If it is significantly less than previous tune checks, it is indicative of insufficient amount of BFB injected. Probable causes are:

## STANDARD OPERATING PROCEDURES

**VOLATILE ORGANICS BY GC/MS**SOP No.: EMAX-8260 Revision No. 10 Effective Date: 06-Jun-14

---

improper spiking, leaks, standard degradation or low vacuum system. Repeat tune check ensuring that BFB was properly spiked or rule out leaks, prepare a fresh BFB standard and repeat the tune check.

- If problem persist, re-tune the instrument and repeat tune check.
- If problem is unresolved, inform the supervisor for further action.

**12.2.2. Initial Calibration**

12.2.2.1. If the %RSD is out of acceptance criteria, consider the following suggestions to correct the problem.

- If one of the standards returns a bias low or bias high on all of the analytes then that point is considered an out-liner. Prepare a standard at that ICAL point and re-analyze.
- If the highest ICAL point appears to be saturated, drop the highest point.
- If the lowest point returns a bias low or bias high response or the peaks are not distinct and sharp, drop the lowest point.

*Note : The lowest calibration point identifies the limit of quantitation (LOQ). Therefore, check that the LOQ is in conformance to the current projects where the ICAL will be used.*

12.2.2.2. If instrument problem is suspected, consider the following suggestion to correct the problem:

- Check the connection and make sure they are air tight and perform maintenance as needed.
- Check the gas flow.
- Re-tune the MS.
- Prepare a fresh standard and repeat calibration.
- Clean the MS source and repeat calibration.
- If problem is unresolved, inform the supervisor for further action.

12.2.3. **Initial Calibration Verification (ICV)** – If the ICV is non-compliant, consider the following suggestions to correct the problem:

- Re-analyze ICV to rule out poor purge.
- If ICV is still out of acceptance criteria, prepare a fresh standard and re-analyze to rule out any preparation error.
- If ICV is still out of acceptance criteria, prepare a fresh ICAL standard and repeat calibration.
- If problem is unresolved, inform the supervisor for further action.

12.2.4. **Daily Calibration Check (DCC)** – If DCC is non-compliant consider the following suggestions to correct the problem:



## STANDARD OPERATING PROCEDURES

**VOLATILE ORGANICS BY GC/MS**SOP No.: EMAX-8260 Revision No. 10 Effective Date: 06-Jun-14

---

- If majority of the analyte response are low and no evidence of leak in the system is apparent, it is indicative of a bad purge or leak in the vial. Re-analyze DCC.
- If problem persist, rule out standard degradation. Prepare a fresh standard and repeat DCC.
- Otherwise execute instrument maintenance and perform ICAL.

12.2.5. Instrument Blank – If instrument blank is non-compliant, consider the following suggestions to correct the problem:

- If trace level of THMs is observed, it is indicative that water filters need replacement. Otherwise, bake the trap at the manufacturer's recommended temperature for about 30 minutes.
- If contamination is high, flush the sample line with methanol and replace the trap.
- If problem is unresolved, inform the supervisor for further action.

**12.3. Preparation Batch QC**

12.3.1. For insufficient amount of sample(s), inform the supervisor immediately for further action.

12.3.2. If MB is non-compliant, consider the suggestions as described in Instrument Blank.

12.3.3. If LCS is non-compliant, consider the following suggestions to correct the problem:

- If result is bias low or high, prepare a fresh standard and re-analyze LCS and the associated samples.
- If problem is unresolved, inform the supervisor for further advice.

12.3.4. If MS is non-compliant consider the following suggestion to correct the problem:

- Check the standard log and analytical log and verify that the spike amount value used for calculation is correct.
- If LCS is within acceptance criteria then and the right amount of spike amount used for calculation is correct, then it is indicative of matrix interference. Discuss the probable matrix interference in the case narrative.

12.4. Discuss water samples that are labeled preserved having a pH  $\geq 2$  and/or residual chlorine  $\geq 5$  mg/L in the case narrative.

12.5. A Non-Conformance Report (NCR) is required when the following circumstances occur.

- Anomalies other than specified in Appendix 1, is observed.
- Sample is out of technical holding time.

12.5.1. Refer to EMAX-QA08 for NCR details.

**13.0 POLLUTION PREVENTION**

13.1. Observe all necessary precautions to avoid spillage of solvent that may go to wastewater drains.

13.2. Prepare all standards in fume hoods.

## STANDARD OPERATING PROCEDURES

**VOLATILE ORGANICS BY GC/MS**SOP No.: EMAX-8260 Revision No. 10 Effective Date: 06-Jun-14

---

**14.0 WASTE MANAGEMENT**

- 14.1. No samples shall be dumped on the laboratory sink.
- 14.2. Separate and properly identify all unused and expired analytical standards for proper disposal.
- 14.3. Place all waste generated during analytical process in properly labeled satellite waste containers for proper collection.
- 14.4. Dispose all unused samples, expired analytical standards and other waste generated during the analytical process in accordance to EMAX-SM03.

**15.0 SUPPLEMENTARY NOTES****15.1. Definition of Terms**

- 15.1.1. Analyte – The specific chemicals or components for which a sample is analyzed; may be a group of chemicals that belong to the same chemical family, and which are analyzed together.
- 15.1.2. Batch – is a group of samples that are prepared and/or analyzed at the same time using the same lot of reagents.
  - 15.1.2.1. **Preparation Batch** - is composed of one to 20 samples of the same matrix, a method blank, a lab control sample and matrix spike/matrix spike duplicate.
  - 15.1.2.2. **Analytical batch** - is composed of prepared samples (extracts, digestates, or concentrates), which are analyzed together as a group using an instrument in conformance to the analytical requirement. An analytical batch can include samples originating from various matrices, preparation batches, and can exceed 20 samples.
- 15.1.3. Detection Limit (DL) – is defined as the smallest analyte concentration that can be demonstrated to be different from zero or a blank concentration at the 99% level of confidence. At the DL, the false positive rate (Type I error) is 1%.
- 15.1.4. Limit of Detection (LOD) – is defined as the smallest amount or concentration of a substance that must be present in a sample in order to be detected at a high level of confidence (99%). At the LOD, the false negative result rate (Type II error) is 1 %.
- 15.1.5. Limit of Quantitation (LOQ) – is at the lowest concentration that produces a quantitative result within specified limits of precision and bias. For DoD projects, the LOQ shall be set at or above the concentration of the lowest initial calibration standard.
- 15.1.6. Safety Data Sheet (SDS) – is written information concerning a chemical physical properties, toxicity, health hazards, fire hazard and reactivity data including storage, spill and handling precautions.
- 15.1.7. Calibration – is a determinant measured from a standard to obtain the correct value of an instrument output.
- 15.1.8. Calibration Blank – is a target-analyte-free solvent subjected to the entire analytical process to establish zero baseline or background value.

## STANDARD OPERATING PROCEDURES

**VOLATILE ORGANICS BY GC/MS**SOP No.: EMAX-8260 Revision No. 10 Effective Date: 06-Jun-14

- 
- 15.1.9. Carry-over – are contaminants retained in the instrument/apparatus from a highly contaminated sample that is passed into the succeeding sample(s).
- 15.1.10. Calibration Check Compounds (CCC) – evaluate the integrity of the system. Variability of these compounds may indicate system leak or reactive sites in the column.
- 15.1.11. Instrument Method – is a file generated to contain the instrument calibration and instrument parameter settings for a particular analysis.
- 15.1.12. Method Blank – is a target-analyte-free sample subjected to the entire sample preparation and/or analytical to monitor contamination.
- 15.1.13. Lab Control Sample (LCS) – is a target-analyte-free sample spiked with a verified known amount of target analyte(s) or a reference material with a certified known value subjected to the entire sample preparation and/or analytical process. LCS is analyzed to monitor the accuracy of the analytical system.
- 15.1.14. Lab Control Sample Duplicate (LCS D) – is a replicate of LCS analyzed to monitor precision in the absence of MS/MSD sample.
- 15.1.15. Sample – is a specimen received in the laboratory bearing a sample label traceable to the accompanying COC. Samples collected in different containers having the same field sample ID are considered the same and therefore labeled with the same lab sample ID unless otherwise specified by the project.
- 15.1.16. Sample Duplicate – is a replicate of a sub-sample taken from one sample, prepared and analyzed within the same preparation batch.
- 15.1.17. Sub-sample – is an aliquot taken from a sample for analysis. Each sub-sample is uniquely identified by the sample preparation ID.
- 15.1.18. Matrix – is a component or form of a sample.
- 15.1.19. Matrix Spike (MS) – is a sample spiked with a verified known amount of target analyte(s) subjected to the entire sample preparation and/or analytical process. MS is analyzed to monitor matrix effect on a method's recovery efficiency.
- 15.1.20. Matrix Spike Duplicate (MS D) – is a replicate of MS analyzed to monitor precision or recovery.
- 15.1.21. Response Factor – is the ratio of the peak area of the target compound in the sample or sample extract.
- 15.1.22. Surrogate – are compounds added to every blank, sample, matrix spike, matrix spike duplicate and standard; used to evaluate analytical efficiency by measuring recovery. Compounds not expected to be detected in environmental media.
- 15.1.23. SPCC – System performance check compounds are compounds that are used to check compound stability and to check for degradation cause by contaminated lines or active sites in the system.
- 15.1.24. Reagent Water – is purified water free from any target analyte or any other substance that may interfere with the analytical process.
- 15.1.25. Reagent Soil – organic-free Ottawa sand or equivalent.
- 15.2. **Application of EMAX QC Procedures**

## STANDARD OPERATING PROCEDURES

**VOLATILE ORGANICS BY GC/MS**SOP No.: EMAX-8260 Revision No. 10 Effective Date: 06-Jun-14

---

15.2.1. The procedures and QC criteria summarized in this SOP applies to all projects when performing Volatile analysis by GC/MS. The standard analyte list and RL are presented in Tables 6 & 7. In instances where there is a project or program QAPP, the requirements given in the project takes precedence over this SOP.

**15.3. Department of Defense (DoD) and Department of Energy (DoE) Projects**

15.3.1. Samples from DoD and DoE sponsored projects follows the Quality Assurance Project Plan (QAPP), Statement of Work (SOW) and/or client's quality control directive. In the absence of QAPP, the DoD Quality Systems Manual (QSM), latest update, is applied.

**16.0 REFERENCES**

- 16.1. U.S. EPA Method 8260B; SW846, as updated
- 16.2. EMAX Quality Systems Manual, as updated

**17.0 APPENDICES****17.1. Tables**

- 17.1.1. Table 1 Initial Calibration Intermediate Standards Preparation
- 17.1.2. Table 2 Initial Calibration Verification/LCS/MS/MSD Intermediate Standards Preparation
- 17.1.3. Table 3 Surrogate/Internal Standards Preparation
- 17.1.4. Table 4 Tuning Solution Standards Preparation
- 17.1.5. Table 5 BFB Key Ion Abundance Criteria
- 17.1.6. Table 6 Typical Analyte List, Quantitation Ions, IS, Surrogates, Calibration Standards, Detection Limits for 5 ml Purge
- 17.1.7. Table 7 Typical Analyte List, Quantitation Ions, IS, Surrogates, Calibration Standards, Detection Limits for 25 ml Purge

**17.2. Figures**

- 17.2.1. Figure 1 Peak Evaluation Techniques
- 17.2.2. Figure 2 Typical Chromatogram
- 17.2.3. Figure 3 Typical ICAL Summary
- 17.2.4. Figure 4 Typical Instrument Performance Check (Tuning)
- 17.2.5. Figure 5 Typical Instrument Performance Check (Tuning) Summary
- 17.2.6. Figure 6 Typical Internal Standard Area and Retention Time Summary
- 17.2.7. Figure 7 Typical Sample Result Summary
- 17.2.8. Figure 8 Typical LCS/LCSD Summary
- 17.2.9. Figure 9 Typical MS/MSD Summary
- 17.2.10. Figure 10 Typical Case Narrative

## STANDARD OPERATING PROCEDURES

**VOLATILE ORGANICS BY GC/MS**SOP No.: EMAX-8260 Revision No. 10 Effective Date: 06-Jun-14

---

**17.3. Appendices**

- 17.3.1. Appendix 1 Summary of Quality Control Procedures
- 17.3.2. Appendix 2 Demonstration of Capability for 25 ml
- 17.3.3. Appendix 3 Demonstration of Capability for 5 ml
- 17.3.4. Appendix 4 Demonstration of Capability for 5 g

**17.4. Forms**

- 17.4.1. 8260FS Sample Preparation Log
- 17.4.2. 8260FA Analytical Run Log
- 17.4.3. 8260FM Instrument Maintenance Log

**Table 1: INITIAL CALIBRATION INTERMEDIATE STANDARDS PREPARATION**

| ICAL/DCC Intermediate Standard | Stock Standard              |                  |                    | Preparation (Solvent: Methanol) |                 | Final Conc. (mg/L) |
|--------------------------------|-----------------------------|------------------|--------------------|---------------------------------|-----------------|--------------------|
|                                | Standard Name               | Source           | Conc. (mg/L)       | Aliquot (μl)                    | Final Vol. (ml) |                    |
| I                              | 1-Chlorohexane              | AccuStandard     | 2000               | 50                              | 2               | 50                 |
|                                | 2-Chloroethylvinylether     | CPI              | 2000               | 50                              | 2               | 50                 |
|                                | Oxygenate Gasoline Additive | AccuStandard     | 2000-10000         | 50                              | 2               | 50 - 250           |
|                                | Custom VOA Mix              | CPI              | 2000, 20000, 40000 | 50                              | 2               | 50, 500, 1000      |
| II                             | VOC Gas Mix                 | Ultra Scientific | 2000               | 250                             | 2               | 250                |
|                                | Vinyl Acetate               | CPI              | 2500               | 200                             | 2               | 250                |
| III                            | Carbon Disulfide            | CPI              | 5000               | 100                             | 2               | 250                |
| IV                             | VOA Calibration Mix 1       | Restek           | 5000               | 100                             | 2               | 250                |
|                                | Acrolein / Acrylonitrile    | AccuStandard     | 5000               | 100                             | 2               | 250                |

**Table 2: INITIAL CALIBRATION VERIFICATION/LCS/MS/MSD INTERMEDIATE STANDARDS PREPARATION**

| ICV / LCS / MS Intermediate Standard | Stock Standard              |                  |                    | Preparation (Solvent: Methanol) |                 | Final Conc. (mg/L) |
|--------------------------------------|-----------------------------|------------------|--------------------|---------------------------------|-----------------|--------------------|
|                                      | Standard Name               | Source           | Conc. (mg/L)       | Aliquot (μl)                    | Final Vol. (ml) |                    |
| I                                    | 1-Chlorohexane              | Ultra Scientific | 1000               | 100                             | 2               | 50                 |
|                                      | 2-Chloroethylvinylether     | AccuStandard     | 2000               | 50                              | 2               | 50                 |
|                                      | California Oxygenate Mix    | Restek           | 2000 - 10000       | 50                              | 2               | 50 – 250           |
|                                      | Custom 8260 Mega Mix        | Restek           | 2000, 20000, 40000 | 50                              | 2               | 50, 500, 1000      |
| II                                   | Volatile Organic Cpds Mix 6 | Supelco          | 2000               | 250                             | 2               | 250                |
|                                      | Vinyl Acetate               | Restek           | 2000               | 250                             | 2               | 250                |
| III                                  | Carbon Disulfide Solution   | Ultra scientific | 5000               | 20                              | 2               | 50                 |
| IV                                   | TCL Volatile Mix 1          | Supelco          | 2000               | 250                             | 2               | 250                |
|                                      | Acrolein / Acrylonitrile    | Ultra Scientific | 2000               | 250                             | 2               | 250                |

**Table 3: SURROGATE / INTERNAL STANDARDS PREPARATION**

| Intermediate Standard | Stock Standard                          |        |              | Preparation (Solvent: Methanol) |                 | Final Conc. (mg/L) |
|-----------------------|---|--------|--------------|---------------------------------|-----------------|--------------------|
|                       | Standard Name                           | Source | Conc. (mg/L) | Aliquot (μl)                    | Final Vol. (ml) |                    |
| Surrogate             | 8260 Surrogate Mix                      | Restek | 2500         | 200                             | 2               | 250                |
| Internal Standard     | Custom 8260 Internal Standard Mix, 3-30 | CPI    | 2500         | 200                             | 2               | 250                |

**Table 4: TUNING SOLUTION STANDARDS PREPARATION**

| BFB Intermediate Standard | Stock Standard |        |              | Preparation (Solvent: Methanol) |                 | Final Conc. (mg/L) |
|---------------------------|----------------|--------|--------------|---------------------------------|-----------------|--------------------|
|                           | Standard Name  | Source | Conc. (mg/L) | Aliquot (μl)                    | Final Vol. (ml) |                    |
| Tuning Compound           | BFB            | Restek | 5000         | 20                              | 2               | 50                 |

**Table 5: BFB KEY ION ABUNDANCE CRITERIA**

| M/z | Required Intensity (relative abundance)        |
|-----|--|
| 50  | 15 to 40% of m/z 95                            |
| 75  | 30 to 60% of m/z 95                            |
| 95  | Base peak, 100% relative abundance             |
| 96  | 5 to 9% of m/z 95                              |
| 173 | Less than 2% of m/z 174                        |
| 174 | Greater than 50% of m/z 95                     |
| 175 | 5 to 9% of m/z 174                             |
| 176 | Greater than 95% but less than 101% of m/z 174 |
| 177 | 5 to 9% of m/z 176                             |

**Table 6: TYPICAL TARGET ANALYTE LIST FOR 5-ml PURGE**

| ANALYTES                              | CHARACTERISTIC ION(S) |               | IS  | SURR   | ICAL ANALYTE CONCENTRATIONS (µg/L) |    |    |     |     |     |     |      | ICV/DCC<br>EV(µg/L) | LCS/MS<br>EV(µg/L) | WATER (µg/L) |     |     | SOIL (µg/Kg) |     |     |
|---------------------------------------|-----------------------|---------------|-----|--------|------------------------------------|----|----|-----|-----|-----|-----|------|---------------------|--------------------|--------------|-----|-----|--------------|-----|-----|
|                                       | PRIMARY               | SECONDARY     |     |        | 1                                  | 2  | 3  | 4   | 5   | 6   | 7   | 8    |                     |                    | DL           | LOD | LOQ | DL           | LOD | LOQ |
| 1,1,1,2-Tetrachloroethane             | 131                   | 133, 119, 117 | IS2 | Sur3   | 2                                  | 5  | 10 | 20  | 50  | 80  | 100 | 200  | 50                  | 50                 | 0.5          | 1   | 5   | 0.5          | 1   | 5   |
| 1,1,1-Trichloroethane                 | 97                    | 99, 61        | IS1 | Sur0/1 | 2                                  | 5  | 10 | 20  | 50  | 80  | 100 | 200  | 50                  | 50                 | 0.5          | 1   | 5   | 0.5          | 1   | 5   |
| 1,1,2,2-Tetrachloroethane             | 83                    | 85            | IS3 | Sur2   | 2                                  | 5  | 10 | 20  | 50  | 80  | 100 | 200  | 50                  | 50                 | 0.5          | 1   | 5   | 0.5          | 1   | 5   |
| 1,1,2-Trichloro-1,2,2-trifluoroethane | 151                   | 153           | IS1 | Sur0/1 | 2                                  | 5  | 10 | 20  | 50  | 80  | 100 | 200  | 50                  | 50                 | 1            | 2   | 5   | 1            | 2   | 5   |
| 1,1,2-Trichloroethane                 | 97                    | 83, 85, 99    | IS2 | Sur3   | 2                                  | 5  | 10 | 20  | 50  | 80  | 100 | 200  | 50                  | 50                 | 0.5          | 1   | 5   | 0.5          | 1   | 5   |
| 1,1-Dichloroethane                    | 63                    | 65, 83        | IS1 | Sur0/1 | 2                                  | 5  | 10 | 20  | 50  | 80  | 100 | 200  | 50                  | 50                 | 0.5          | 1   | 5   | 0.5          | 1   | 5   |
| 1,1-Dichloroethene                    | 61                    | 63, 96        | IS1 | Sur0/1 | 2                                  | 5  | 10 | 20  | 50  | 80  | 100 | 200  | 50                  | 50                 | 0.5          | 1   | 5   | 0.5          | 1   | 5   |
| 1,1-Dichloropropene                   | 110                   | 112           | IS1 | Sur0/1 | 2                                  | 5  | 10 | 20  | 50  | 80  | 100 | 200  | 50                  | 50                 | 0.5          | 1   | 5   | 0.5          | 1   | 5   |
| 1,2,3-Trichlorobenzene                | 180                   | 182, 145      | IS3 | Sur2   | 2                                  | 5  | 10 | 20  | 50  | 80  | 100 | 200  | 50                  | 50                 | 0.5          | 1   | 5   | 1            | 2   | 5   |
| 1,2,3-Trichloropropane                | 110                   | 61, 77        | IS3 | Sur2   | 2                                  | 5  | 10 | 20  | 50  | 80  | 100 | 200  | 50                  | 50                 | 1            | 2   | 5   | 1            | 2   | 5   |
| 1,2,4-Trichlorobenzene                | 180                   | 182, 145      | IS3 | Sur2   | 2                                  | 5  | 10 | 20  | 50  | 80  | 100 | 200  | 50                  | 50                 | 0.5          | 1   | 5   | 1            | 2   | 5   |
| 1,2,4-Trimethylbenzene                | 105                   | 120           | IS3 | Sur2   | 2                                  | 5  | 10 | 20  | 50  | 80  | 100 | 200  | 50                  | 50                 | 0.5          | 1   | 5   | 0.55         | 1   | 5   |
| 1,2-Dibromo-3-chloropropane           | 157                   | 155, 75       | IS3 | Sur2   | 2                                  | 5  | 10 | 20  | 50  | 80  | 100 | 200  | 50                  | 50                 | 1            | 2   | 5   | 1            | 2   | 5   |
| 1,2-Dibromoethane                     | 107                   | 109           | IS2 | Sur3   | 2                                  | 5  | 10 | 20  | 50  | 80  | 100 | 200  | 50                  | 50                 | 0.5          | 1   | 5   | 0.5          | 1   | 5   |
| 1,2-Dichlorobenzene                   | 146                   | 111, 148      | IS3 | Sur2   | 2                                  | 5  | 10 | 20  | 50  | 80  | 100 | 200  | 50                  | 50                 | 0.5          | 1   | 5   | 0.5          | 1   | 5   |
| 1,2-Dichloroethane                    | 62                    | 64            | IS1 | Sur0/1 | 2                                  | 5  | 10 | 20  | 50  | 80  | 100 | 200  | 50                  | 50                 | 0.5          | 1   | 5   | 0.5          | 1   | 5   |
| 1,2-Dichloropropane                   | 63                    | 41, 76        | IS1 | Sur0/1 | 2                                  | 5  | 10 | 20  | 50  | 80  | 100 | 200  | 50                  | 50                 | 0.5          | 1   | 5   | 0.5          | 1   | 5   |
| 1,3,5-Trimethylbenzene                | 105                   | 120, 119      | IS3 | Sur2   | 2                                  | 5  | 10 | 20  | 50  | 80  | 100 | 200  | 50                  | 50                 | 0.5          | 1   | 5   | 0.59         | 1   | 5   |
| 1,3-Dichlorobenzene                   | 146                   | 111, 148      | IS3 | Sur2   | 2                                  | 5  | 10 | 20  | 50  | 80  | 100 | 200  | 50                  | 50                 | 0.5          | 1   | 5   | 0.52         | 1   | 5   |
| 1,3-Dichloropropane                   | 76                    | 78            | IS2 | Sur3   | 2                                  | 5  | 10 | 20  | 50  | 80  | 100 | 200  | 50                  | 50                 | 0.5          | 1   | 5   | 0.5          | 1   | 5   |
| 1,4-Dichlorobenzene                   | 146                   | 111, 148      | IS3 | Sur2   | 2                                  | 5  | 10 | 20  | 50  | 80  | 100 | 200  | 50                  | 50                 | 0.5          | 1   | 5   | 0.5          | 1   | 5   |
| 1-Chlorohexane                        | 91                    | 93, 55, 56    | IS2 | Sur3   | 2                                  | 5  | 10 | 20  | 50  | 80  | 100 | 200  | 50                  | 50                 | 0.5          | 1   | 5   | 0.58         | 1   | 5   |
| 2,2-Dichloropropane                   | 77                    | 97, 79        | IS1 | Sur0/1 | 2                                  | 5  | 10 | 20  | 50  | 80  | 100 | 200  | 50                  | 50                 | 1            | 2   | 5   | 1            | 2   | 5   |
| 2-Butanone (MEK)                      | 43                    | 72            | IS1 | Sur0/1 | 10                                 | 25 | 50 | 100 | 250 | 400 | 500 | 1000 | 250                 | 250                | 2.5          | 5   | 10  | 2.5          | 5   | 10  |
| 2-Chloroethyl vinyl ether             | 63                    | 65, 106       | IS1 | Sur0/1 | 2                                  | 5  | 10 | 20  | 50  | 80  | 100 | 200  | 50                  | 50                 | 1            | 2   | 5   | 1            | 2   | 5   |
| 2-Chlorotoluene                       | 91                    | 126           | IS3 | Sur2   | 2                                  | 5  | 10 | 20  | 50  | 80  | 100 | 200  | 50                  | 50                 | 0.5          | 1   | 5   | 0.82         | 1   | 5   |
| 2-Hexanone (MBK)                      | 43                    | 58, 100       | IS2 | Sur3   | 10                                 | 25 | 50 | 100 | 250 | 400 | 500 | 1000 | 250                 | 250                | 2.5          | 5   | 10  | 2.86         | 5   | 10  |
| 4-Chlorotoluene                       | 91                    | 126           | IS3 | Sur2   | 2                                  | 5  | 10 | 20  | 50  | 80  | 100 | 200  | 50                  | 50                 | 0.61         | 1   | 5   | 0.67         | 1   | 5   |
| 4-Methyl-2-pentanone (MIBK)           | 43                    | 58, 85, 100   | IS1 | Sur0/1 | 10                                 | 25 | 50 | 100 | 250 | 400 | 500 | 1000 | 250                 | 250                | 2.5          | 5   | 10  | 2.75         | 5   | 10  |
| Acetone                               | 43                    | 58, 42        | IS1 | Sur0/1 | 10                                 | 25 | 50 | 100 | 250 | 400 | 500 | 1000 | 250                 | 250                | 2.5          | 5   | 10  | 3.06         | 5   | 10  |
| Acrolein                              | 56                    | 55            | IS1 | Sur0/1 | 10                                 | 25 | 50 | 100 | 250 | 400 | 500 | 1000 | 250                 | 250                | 2.5          | 5   | 10  | 2.5          | 5   | 10  |
| Acrylonitrile                         | 53                    | 52, 51        | IS1 | Sur0/1 | 10                                 | 25 | 50 | 100 | 250 | 400 | 500 | 1000 | 250                 | 250                | 2.5          | 5   | 10  | 2.5          | 5   | 10  |
| Benzene                               | 78                    | 77, 52        | IS1 | Sur0/1 | 2                                  | 5  | 10 | 20  | 50  | 80  | 100 | 200  | 50                  | 50                 | 0.5          | 1   | 5   | 0.5          | 1   | 5   |
| Bromobenzene                          | 156                   | 77, 158       | IS3 | Sur2   | 2                                  | 5  | 10 | 20  | 50  | 80  | 100 | 200  | 50                  | 50                 | 0.5          | 1   | 5   | 0.5          | 1   | 5   |
| Bromochloromethane                    | 49                    | 128, 130      | IS1 | Sur0/1 | 2                                  | 5  | 10 | 20  | 50  | 80  | 100 | 200  | 50                  | 50                 | 0.5          | 1   | 5   | 0.5          | 1   | 5   |
| Bromodichloromethane                  | 83                    | 85            | IS1 | Sur0/1 | 2                                  | 5  | 10 | 20  | 50  | 80  | 100 | 200  | 50                  | 50                 | 0.5          | 1   | 5   | 0.5          | 1   | 5   |
| Bromoform                             | 173                   | 171, 175      | IS3 | Sur2   | 2                                  | 5  | 10 | 20  | 50  | 80  | 100 | 200  | 50                  | 50                 | 0.5          | 1   | 5   | 1            | 2   | 5   |
| Bromomethane                          | 94                    | 96            | IS1 | Sur0/1 | 2                                  | 5  | 10 | 20  | 50  | 80  | 100 | 200  | 50                  | 50                 | 1.1          | 2   | 5   | 1.81         | 2   | 5   |



**Table 6: TYPICAL TARGET ANALYTE LIST FOR 5-ml PURGE**

| ANALYTES                      | CHARACTERISTIC ION(S) |               | IS  | SURR   | ICAL ANALYTE CONCENTRATIONS (µg/L) |    |    |     |     |     |     |      | ICV/DCC<br>EV(µg/L) | LCS/MS<br>EV(µg/L) | WATER (µg/L) |     |     | SOIL (µg/Kg) |     |     |
|-------------------------------|-----------------------|---------------|-----|--------|------------------------------------|----|----|-----|-----|-----|-----|------|---------------------|--------------------|--------------|-----|-----|--------------|-----|-----|
|                               | PRIMARY               | SECONDARY     |     |        | 1                                  | 2  | 3  | 4   | 5   | 6   | 7   | 8    |                     |                    | DL           | LOD | LOQ | DL           | LOD | LOQ |
| Carbon disulfide              | 76                    | 78            | IS1 | Sur0/1 | 2                                  | 5  | 10 | 20  | 50  | 80  | 100 | 200  | 50                  | 50                 | 0.5          | 1   | 5   | 0.5          | 1   | 5   |
| Carbon tetrachloride          | 119                   | 117           | IS1 | Sur0/1 | 2                                  | 5  | 10 | 20  | 50  | 80  | 100 | 200  | 50                  | 50                 | 0.5          | 1   | 5   | 0.54         | 1   | 5   |
| Chlorobenzene                 | 112                   | 51, 77, 114   | IS2 | Sur3   | 2                                  | 5  | 10 | 20  | 50  | 80  | 100 | 200  | 50                  | 50                 | 0.5          | 1   | 5   | 0.5          | 1   | 5   |
| Chloroethane                  | 64                    | 49, 66        | IS1 | Sur0/1 | 2                                  | 5  | 10 | 20  | 50  | 80  | 100 | 200  | 50                  | 50                 | 1            | 2   | 5   | 1            | 2   | 5   |
| Chloroform                    | 83                    | 85, 47        | IS1 | Sur0/1 | 2                                  | 5  | 10 | 20  | 50  | 80  | 100 | 200  | 50                  | 50                 | 0.5          | 1   | 5   | 0.5          | 1   | 5   |
| Chloromethane                 | 50                    | 52            | IS1 | Sur0/1 | 2                                  | 5  | 10 | 20  | 50  | 80  | 100 | 200  | 50                  | 50                 | 1            | 2   | 5   | 1.02         | 2   | 5   |
| cis-1,2-Dichloroethene        | 96                    | 61, 98        | IS1 | Sur0/1 | 2                                  | 5  | 10 | 20  | 50  | 80  | 100 | 200  | 50                  | 50                 | 0.5          | 1   | 5   | 0.5          | 1   | 5   |
| cis-1,3-Dichloropropene       | 75                    | 77, 39, 110   | IS1 | Sur0/1 | 2                                  | 5  | 10 | 20  | 50  | 80  | 100 | 200  | 50                  | 50                 | 0.5          | 1   | 5   | 0.5          | 1   | 5   |
| Dibromochloromethane          | 129                   | 127           | IS2 | Sur3   | 2                                  | 5  | 10 | 20  | 50  | 80  | 100 | 200  | 50                  | 50                 | 0.5          | 1   | 5   | 0.5          | 1   | 5   |
| Dibromomethane                | 93                    | 95, 174       | IS1 | Sur0/1 | 2                                  | 5  | 10 | 20  | 50  | 80  | 100 | 200  | 50                  | 50                 | 0.5          | 1   | 5   | 0.5          | 1   | 5   |
| Dichlorodifluoromethane       | 85                    | 87            | IS1 | Sur0/1 | 2                                  | 5  | 10 | 20  | 50  | 80  | 100 | 200  | 50                  | 50                 | 1.3          | 2   | 5   | 1.16         | 2   | 5   |
| Dichlorofluoromethane         | 67                    | 69            | IS1 | Sur0/1 | 2                                  | 5  | 10 | 20  | 50  | 80  | 100 | 200  | 50                  | 50                 | 0.5          | 1   | 5   | 0.5          | 1   | 5   |
| Diisopropyl ether (DIPE)      | 45                    | 87            | IS1 | Sur0/1 | 2                                  | 5  | 10 | 20  | 50  | 80  | 100 | 200  | 50                  | 50                 | 0.5          | 1   | 5   | 0.5          | 1   | 5   |
| Ethyl Methacrylate            | 69                    | 99, 41        | IS2 | Sur3   | 2                                  | 5  | 10 | 20  | 50  | 80  | 100 | 200  | 50                  | 50                 | 1            | 2   | 5   | 1            | 2   | 5   |
| Ethylbenzene                  | 91                    | 106           | IS2 | Sur3   | 2                                  | 5  | 10 | 20  | 50  | 80  | 100 | 200  | 50                  | 50                 | 0.5          | 1   | 5   | 0.5          | 1   | 5   |
| Ethyl-tert-butyl ether (ETBE) | 59                    | 87            | IS1 | Sur0/1 | 2                                  | 5  | 10 | 20  | 50  | 80  | 100 | 200  | 50                  | 50                 | 0.5          | 1   | 5   | 0.5          | 1   | 5   |
| Hexachlorobutadiene           | 225                   | 223, 227      | IS3 | Sur2   | 2                                  | 5  | 10 | 20  | 50  | 80  | 100 | 200  | 50                  | 50                 | 0.5          | 1   | 5   | 1            | 2   | 5   |
| Iodomethane                   | 142                   | 127           | IS1 | Sur0/1 | 2                                  | 5  | 10 | 20  | 50  | 80  | 100 | 200  | 50                  | 50                 | 0.5          | 1   | 5   | 1            | 2   | 5   |
| Isopropylbenzene              | 105                   | 120, 79, 103  | IS3 | Sur2   | 2                                  | 5  | 10 | 20  | 50  | 80  | 100 | 200  | 50                  | 50                 | 0.5          | 1   | 5   | 0.64         | 1   | 5   |
| m/p-Xylenes                   | 91                    | 106           | IS2 | Sur3   | 4                                  | 10 | 20 | 40  | 100 | 160 | 200 | 400  | 100                 | 100                | 1            | 2   | 10  | 1            | 2   | 10  |
| Methylene chloride            | 49                    | 84, 86        | IS1 | Sur0/1 | 2                                  | 5  | 10 | 20  | 50  | 80  | 100 | 200  | 50                  | 50                 | 0.5          | 1   | 5   | 1            | 2   | 5   |
| Methyl-t-butyl ether (MTBE)   | 73                    | 57            | IS1 | Sur0/1 | 2                                  | 5  | 10 | 20  | 50  | 80  | 100 | 200  | 50                  | 50                 | 0.5          | 1   | 5   | 0.5          | 1   | 5   |
| Naphthalene                   | 128                   | 127           | IS3 | Sur2   | 2                                  | 5  | 10 | 20  | 50  | 80  | 100 | 200  | 50                  | 50                 | 1            | 2   | 5   | 1            | 2   | 5   |
| n-Butylbenzene                | 91                    | 92, 134       | IS3 | Sur2   | 2                                  | 5  | 10 | 20  | 50  | 80  | 100 | 200  | 50                  | 50                 | 0.73         | 1   | 5   | 0.7          | 1   | 5   |
| n-Propylbenzene               | 91                    | 65, 120       | IS3 | Sur2   | 2                                  | 5  | 10 | 20  | 50  | 80  | 100 | 200  | 50                  | 50                 | 0.51         | 1   | 5   | 0.65         | 1   | 5   |
| o-Xylene                      | 91                    | 106           | IS2 | Sur3   | 2                                  | 5  | 10 | 20  | 50  | 80  | 100 | 200  | 50                  | 50                 | 0.5          | 1   | 5   | 0.5          | 1   | 5   |
| p-Isopropyltoluene            | 119                   | 91, 134       | IS3 | Sur2   | 2                                  | 5  | 10 | 20  | 50  | 80  | 100 | 200  | 50                  | 50                 | 0.56         | 1   | 5   | 0.62         | 1   | 5   |
| sec-Butylbenzene              | 105                   | 134           | IS3 | Sur2   | 2                                  | 5  | 10 | 20  | 50  | 80  | 100 | 200  | 50                  | 50                 | 0.5          | 1   | 5   | 0.67         | 1   | 5   |
| Styrene                       | 104                   | 78, 103       | IS2 | Sur3   | 2                                  | 5  | 10 | 20  | 50  | 80  | 100 | 200  | 50                  | 50                 | 0.5          | 1   | 5   | 0.5          | 1   | 5   |
| tert-Amylmethyl ether (TAME)  | 87                    | 55, 73        | IS1 | Sur0/1 | 2                                  | 5  | 10 | 20  | 50  | 80  | 100 | 200  | 50                  | 50                 | 0.5          | 1   | 5   | 0.5          | 1   | 5   |
| tert-Butyl alcohol (TBA)      | 59                    | 41            | IS1 | Sur0/1 | 10                                 | 25 | 50 | 100 | 250 | 400 | 500 | 1000 | 250                 | 250                | 7.1          | 10  | 25  | 9.18         | 10  | 20  |
| tert-Butylbenzene             | 134                   | 91, 119       | IS3 | Sur2   | 2                                  | 5  | 10 | 20  | 50  | 80  | 100 | 200  | 50                  | 50                 | 0.5          | 1   | 5   | 0.62         | 1   | 5   |
| Tetrachloroethene             | 164                   | 129, 131, 166 | IS2 | Sur3   | 2                                  | 5  | 10 | 20  | 50  | 80  | 100 | 200  | 50                  | 50                 | 0.52         | 1   | 5   | 0.5          | 1   | 5   |
| Toluene                       | 91                    | 92            | IS2 | Sur3   | 2                                  | 5  | 10 | 20  | 50  | 80  | 100 | 200  | 50                  | 50                 | 0.5          | 1   | 5   | 0.5          | 1   | 5   |
| trans-1,2-Dichloroethene      | 61                    | 96, 98        | IS1 | Sur0/1 | 2                                  | 5  | 10 | 20  | 50  | 80  | 100 | 200  | 50                  | 50                 | 0.5          | 1   | 5   | 0.5          | 1   | 5   |
| trans-1,3-Dichloropropene     | 75                    | 77, 39        | IS2 | Sur3   | 2                                  | 5  | 10 | 20  | 50  | 80  | 100 | 200  | 50                  | 50                 | 0.5          | 1   | 5   | 0.5          | 1   | 5   |
| trans-1,4-Dichloro-2-butene   | 53                    | 88            | IS3 | Sur2   | 2                                  | 5  | 10 | 20  | 50  | 80  | 100 | 200  | 50                  | 50                 | 1            | 2   | 5   | 1            | 2   | 5   |
| Trichloroethene               | 130                   | 97, 132, 95   | IS1 | Sur0/1 | 2                                  | 5  | 10 | 20  | 50  | 80  | 100 | 200  | 50                  | 50                 | 0.5          | 1   | 5   | 0.5          | 1   | 5   |

**Table 6: TYPICAL TARGET ANALYTE LIST FOR 5-ml PURGE**

| ANALYTES                     | CHARACTERISTIC ION(S) |           | IS  | SURR   | ICAL ANALYTE CONCENTRATIONS (µg/L) |   |    |    |    |    |     |     | ICV/DCC<br>EV(µg/L) | LCS/MS<br>EV(µg/L) | WATER (µg/L) |     |     | SOIL (µg/Kg) |     |     |
|------------------------------|-----------------------|-----------|-----|--------|------------------------------------|---|----|----|----|----|-----|-----|---------------------|--------------------|--------------|-----|-----|--------------|-----|-----|
|                              | PRIMARY               | SECONDARY |     |        | 1                                  | 2 | 3  | 4  | 5  | 6  | 7   | 8   |                     |                    | DL           | LOD | LOQ | DL           | LOD | LOQ |
| Trichlorofluoromethane       | 101                   | 103       | IS1 | Sur0/1 | 2                                  | 5 | 10 | 20 | 50 | 80 | 100 | 200 | 50                  | 50                 | 0.86         | 1   | 5   | 1.06         | 2   | 5   |
| Vinyl acetate                | 43                    | 86        | IS1 | Sur0/1 | 2                                  | 5 | 10 | 20 | 50 | 80 | 100 | 200 | 50                  | 50                 | 1            | 2   | 5   | 1.26         | 2   | 5   |
| Vinyl chloride               | 62                    | 64        | IS1 | Sur0/1 | 2                                  | 5 | 10 | 20 | 50 | 80 | 100 | 200 | 50                  | 50                 | 0.61         | 1   | 5   | 1            | 2   | 5   |
| Dibromofluoromethane (Sur0)  | 111                   | 113, 192  | IS1 |        | 2                                  | 5 | 10 | 20 | 50 | 80 | 100 | 200 | 50                  | 50                 | 1            | 2   | 5   | 0.5          | 1   | 5   |
| 1,2-Dichloroethane-d4 (Sur1) | 65                    | 102       | IS1 |        | 2                                  | 5 | 10 | 20 | 50 | 80 | 100 | 200 | 50                  | 50                 | 1            | 2   | 5   | 1            | 2   | 5   |
| 4-Bromofluorobenzene (Sur2)  | 95                    | 174, 176  | IS3 |        | 2                                  | 5 | 10 | 20 | 50 | 80 | 100 | 200 | 50                  | 50                 | 1            | 2   | 5   | 1            | 2   | 5   |
| Toluene-D8 (Sur3)            | 98                    | 100       | IS2 |        | 2                                  | 5 | 10 | 20 | 50 | 80 | 100 | 200 | 50                  | 50                 | 1            | 2   | 5   | 1            | 2   | 5   |
| 1,4-Difluorobenzene (IS1)    | 114                   | 88        |     |        |                                    |   |    |    |    |    |     |     |                     |                    |              |     |     |              |     |     |
| Chlorobenzene-d5 (IS2)       | 117                   | 82, 119   |     |        |                                    |   |    |    |    |    |     |     |                     |                    |              |     |     |              |     |     |
| 1,2-Dichlorobenzene-d4 (IS3) | 152                   | 150       |     |        |                                    |   |    |    |    |    |     |     |                     |                    |              |     |     |              |     |     |

Note: Since, retention time of Dibromofluoromethane (Sur0) and 1,2-Dichloroethane-d4 (Sur1) is too close (~43 sec) hence, Dibromofluoromethane (Sur0) is only used when required by the project.

**Table 7: TYPICAL TARGET ANALYTE LIST FOR 25-ml PURGE**

| Analytes                              | CHARACTERISTIC ION(S) |               | IS  | SURR   | ICAL ANALYTE CONCENTRATIONS (µg/L) |     |   |    |    |    |     |     |     | ICV/DCC<br>EV(µg/L) | LCS/MS<br>EV(µg/L) | WATER (µg/L) |     |     |
|---------------------------------------|-----------------------|---------------|-----|--------|------------------------------------|-----|---|----|----|----|-----|-----|-----|---------------------|--------------------|--------------|-----|-----|
|                                       | PRIMARY               | SECONDARY     |     |        | 1                                  | 2   | 3 | 4  | 5  | 6  | 7   | 8   | 9   |                     |                    | DL           | LOD | LOQ |
| 1,1,1,2-Tetrachloroethane             | 131                   | 133, 119, 117 | IS2 | Sur3   | 0.3                                | 0.5 | 1 | 2  | 5  | 10 | 20  | 30  | 40  | 10                  | 10                 | 0.1          | 0.2 | 0.5 |
| 1,1,1-Trichloroethane                 | 97                    | 99, 61        | IS1 | Sur0/1 | 0.3                                | 0.5 | 1 | 2  | 5  | 10 | 20  | 30  | 40  | 10                  | 10                 | 0.1          | 0.2 | 0.5 |
| 1,1,2,2-Tetrachloroethane             | 83                    | 85            | IS3 | Sur2   | 0.3                                | 0.5 | 1 | 2  | 5  | 10 | 20  | 30  | 40  | 10                  | 10                 | 0.11         | 0.2 | 0.5 |
| 1,1,2-Trichloro-1,2,2-trifluoroethane | 151                   | 153           | IS1 | Sur0/1 | 0.3                                | 0.5 | 1 | 2  | 5  | 10 | 20  | 30  | 40  | 10                  | 10                 | 0.17         | 0.3 | 0.5 |
| 1,1,2-Trichloroethane                 | 97                    | 83, 85, 99    | IS2 | Sur3   | 0.3                                | 0.5 | 1 | 2  | 5  | 10 | 20  | 30  | 40  | 10                  | 10                 | 0.1          | 0.2 | 0.5 |
| 1,1-Dichloroethane                    | 63                    | 65, 83        | IS1 | Sur0/1 | 0.3                                | 0.5 | 1 | 2  | 5  | 10 | 20  | 30  | 40  | 10                  | 10                 | 0.1          | 0.2 | 0.5 |
| 1,1-Dichloroethene                    | 61                    | 63, 96        | IS1 | Sur0/1 | 0.3                                | 0.5 | 1 | 2  | 5  | 10 | 20  | 30  | 40  | 10                  | 10                 | 0.1          | 0.2 | 0.5 |
| 1,1-Dichloropropene                   | 110                   | 112           | IS1 | Sur0/1 | 0.3                                | 0.5 | 1 | 2  | 5  | 10 | 20  | 30  | 40  | 10                  | 10                 | 0.1          | 0.2 | 0.5 |
| 1,2,3-Trichlorobenzene                | 180                   | 182, 145      | IS3 | Sur2   | 0.3                                | 0.5 | 1 | 2  | 5  | 10 | 20  | 30  | 40  | 10                  | 10                 | 0.15         | 0.3 | 0.5 |
| 1,2,3-Trichloropropane                | 110                   | 61, 77        | IS3 | Sur2   | 0.3                                | 0.5 | 1 | 2  | 5  | 10 | 20  | 30  | 40  | 10                  | 10                 | 0.25         | 0.5 | 1   |
| 1,2,4-Trichlorobenzene                | 180                   | 182, 145      | IS3 | Sur2   | 0.3                                | 0.5 | 1 | 2  | 5  | 10 | 20  | 30  | 40  | 10                  | 10                 | 0.15         | 0.3 | 0.5 |
| 1,2,4-Trimethylbenzene                | 105                   | 120           | IS3 | Sur2   | 0.3                                | 0.5 | 1 | 2  | 5  | 10 | 20  | 30  | 40  | 10                  | 10                 | 0.11         | 0.2 | 0.5 |
| 1,2-Dibromo-3-chloropropane           | 157                   | 155, 75       | IS3 | Sur2   | 0.3                                | 0.5 | 1 | 2  | 5  | 10 | 20  | 30  | 40  | 10                  | 10                 | 0.25         | 0.5 | 1   |
| 1,2-Dibromoethane                     | 107                   | 109           | IS2 | Sur3   | 0.3                                | 0.5 | 1 | 2  | 5  | 10 | 20  | 30  | 40  | 10                  | 10                 | 0.1          | 0.2 | 0.5 |
| 1,2-Dichlorobenzene                   | 146                   | 111, 148      | IS3 | Sur2   | 0.3                                | 0.5 | 1 | 2  | 5  | 10 | 20  | 30  | 40  | 10                  | 10                 | 0.1          | 0.2 | 0.5 |
| 1,2-Dichloroethane                    | 62                    | 64            | IS1 | Sur0/1 | 0.3                                | 0.5 | 1 | 2  | 5  | 10 | 20  | 30  | 40  | 10                  | 10                 | 0.1          | 0.2 | 0.5 |
| 1,2-Dichloropropane                   | 63                    | 41, 76        | IS1 | Sur0/1 | 0.3                                | 0.5 | 1 | 2  | 5  | 10 | 20  | 30  | 40  | 10                  | 10                 | 0.1          | 0.2 | 0.5 |
| 1,3,5-Trimethylbenzene                | 105                   | 120, 119      | IS3 | Sur2   | 0.3                                | 0.5 | 1 | 2  | 5  | 10 | 20  | 30  | 40  | 10                  | 10                 | 0.13         | 0.2 | 0.5 |
| 1,3-Dichlorobenzene                   | 146                   | 111, 148      | IS3 | Sur2   | 0.3                                | 0.5 | 1 | 2  | 5  | 10 | 20  | 30  | 40  | 10                  | 10                 | 0.11         | 0.2 | 0.5 |
| 1,3-Dichloropropane                   | 76                    | 78            | IS2 | Sur3   | 0.3                                | 0.5 | 1 | 2  | 5  | 10 | 20  | 30  | 40  | 10                  | 10                 | 0.1          | 0.2 | 0.5 |
| 1,4-Dichlorobenzene                   | 146                   | 111, 148      | IS3 | Sur2   | 0.3                                | 0.5 | 1 | 2  | 5  | 10 | 20  | 30  | 40  | 10                  | 10                 | 0.1          | 0.2 | 0.5 |
| 1-Chlorohexane                        | 91                    | 93, 55, 56    | IS2 | Sur3   | 0.3                                | 0.5 | 1 | 2  | 5  | 10 | 20  | 30  | 40  | 10                  | 10                 | 0.14         | 0.2 | 0.5 |
| 2,2-Dichloropropane                   | 77                    | 97, 79        | IS1 | Sur0/1 | 0.3                                | 0.5 | 1 | 2  | 5  | 10 | 20  | 30  | 40  | 10                  | 10                 | 0.16         | 0.2 | 0.5 |
| 2-Butanone (MEK)                      | 43                    | 72            | IS1 | Sur0/1 | 1.5                                | 2.5 | 5 | 10 | 25 | 50 | 100 | 150 | 200 | 50                  | 50                 | 2            | 4   | 10  |
| 2-Chloroethyl vinyl ether             | 63                    | 65, 106       | IS1 | Sur0/1 | 0.3                                | 0.5 | 1 | 2  | 5  | 10 | 20  | 30  | 40  | 10                  | 10                 | 0.5          | 1   | 2   |
| 2-Chlorotoluene                       | 91                    | 126           | IS3 | Sur2   | 0.3                                | 0.5 | 1 | 2  | 5  | 10 | 20  | 30  | 40  | 10                  | 10                 | 0.12         | 0.2 | 0.5 |
| 2-Hexanone (MBK)                      | 43                    | 58, 100       | IS2 | Sur3   | 1.5                                | 2.5 | 5 | 10 | 25 | 50 | 100 | 150 | 200 | 50                  | 50                 | 2.3          | 4   | 5   |
| 4-Chlorotoluene                       | 91                    | 126           | IS3 | Sur2   | 0.3                                | 0.5 | 1 | 2  | 5  | 10 | 20  | 30  | 40  | 10                  | 10                 | 0.11         | 0.2 | 0.5 |
| 4-Methyl-2-pentanone (MIBK)           | 43                    | 58, 85, 100   | IS1 | Sur0/1 | 1.5                                | 2.5 | 5 | 10 | 25 | 50 | 100 | 150 | 200 | 50                  | 50                 | 2.2          | 4   | 5   |
| Acetone                               | 43                    | 58, 42        | IS1 | Sur0/1 | 1.5                                | 2.5 | 5 | 10 | 25 | 50 | 100 | 150 | 200 | 50                  | 50                 | 2.6          | 5   | 10  |
| Acrolein                              | 56                    | 55            | IS1 | Sur0/1 | 1.5                                | 2.5 | 5 | 10 | 25 | 50 | 100 | 150 | 200 | 50                  | 50                 | 2.5          | 5   | 10  |
| Acrylonitrile                         | 53                    | 52, 51        | IS1 | Sur0/1 | 1.5                                | 2.5 | 5 | 10 | 25 | 50 | 100 | 150 | 200 | 50                  | 50                 | 2.5          | 5   | 10  |
| Benzene                               | 78                    | 77, 52        | IS1 | Sur0/1 | 0.3                                | 0.5 | 1 | 2  | 5  | 10 | 20  | 30  | 40  | 10                  | 10                 | 0.1          | 0.2 | 0.5 |

**Table 7: TYPICAL TARGET ANALYTE LIST FOR 25-ml PURGE**

| Analytes                      | CHARACTERISTIC ION(S) |              | IS  | SURR   | ICAL ANALYTE CONCENTRATIONS (µg/L) |     |   |   |    |    |    |    |    | ICV/DCC<br>EV(µg/L) | LCS/MS<br>EV(µg/L) | WATER (µg/L) |     |     |
|-------------------------------|-----------------------|--------------|-----|--------|------------------------------------|-----|---|---|----|----|----|----|----|---------------------|--------------------|--------------|-----|-----|
|                               | PRIMARY               | SECONDARY    |     |        | 1                                  | 2   | 3 | 4 | 5  | 6  | 7  | 8  | 9  |                     |                    | DL           | LOD | LOQ |
| Bromobenzene                  | 156                   | 77, 158      | IS3 | Sur2   | 0.3                                | 0.5 | 1 | 2 | 5  | 10 | 20 | 30 | 40 | 10                  | 10                 | 0.1          | 0.2 | 0.5 |
| Bromochloromethane            | 49                    | 128, 130     | IS1 | Sur0/1 | 0.3                                | 0.5 | 1 | 2 | 5  | 10 | 20 | 30 | 40 | 10                  | 10                 | 0.11         | 0.2 | 0.5 |
| Bromodichloromethane          | 83                    | 85           | IS1 | Sur0/1 | 0.3                                | 0.5 | 1 | 2 | 5  | 10 | 20 | 30 | 40 | 10                  | 10                 | 0.1          | 0.2 | 0.5 |
| Bromoform                     | 173                   | 171, 175     | IS3 | Sur2   | 0.3                                | 0.5 | 1 | 2 | 5  | 10 | 20 | 30 | 40 | 10                  | 10                 | 0.15         | 0.3 | 0.5 |
| Bromomethane                  | 94                    | 96           | IS1 | Sur0/1 | 0.3                                | 0.5 | 1 | 2 | 5  | 10 | 20 | 30 | 40 | 10                  | 10                 | 0.16         | 0.3 | 0.5 |
| Carbon disulfide              | 76                    | 78           | IS1 | Sur0/1 | 0.3                                | 0.5 | 1 | 2 | 5  | 10 | 20 | 30 | 40 | 10                  | 10                 | 0.1          | 0.2 | 0.5 |
| Carbon tetrachloride          | 119                   | 117          | IS1 | Sur0/1 | 0.3                                | 0.5 | 1 | 2 | 5  | 10 | 20 | 30 | 40 | 10                  | 10                 | 0.1          | 0.2 | 0.5 |
| Chlorobenzene                 | 112                   | 51, 77, 114  | IS2 | Sur3   | 0.3                                | 0.5 | 1 | 2 | 5  | 10 | 20 | 30 | 40 | 10                  | 10                 | 0.1          | 0.2 | 0.5 |
| Chloroethane                  | 64                    | 49, 66       | IS1 | Sur0/1 | 0.3                                | 0.5 | 1 | 2 | 5  | 10 | 20 | 30 | 40 | 10                  | 10                 | 0.27         | 0.3 | 0.5 |
| Chloroform                    | 83                    | 85, 47       | IS1 | Sur0/1 | 0.3                                | 0.5 | 1 | 2 | 5  | 10 | 20 | 30 | 40 | 10                  | 10                 | 0.1          | 0.2 | 0.5 |
| Chloromethane                 | 50                    | 52           | IS1 | Sur0/1 | 0.3                                | 0.5 | 1 | 2 | 5  | 10 | 20 | 30 | 40 | 10                  | 10                 | 0.15         | 0.3 | 0.5 |
| cis-1,2-Dichloroethene        | 96                    | 61, 98       | IS1 | Sur0/1 | 0.3                                | 0.5 | 1 | 2 | 5  | 10 | 20 | 30 | 40 | 10                  | 10                 | 0.1          | 0.2 | 0.5 |
| cis-1,3-Dichloropropene       | 75                    | 77, 39, 110  | IS1 | Sur0/1 | 0.3                                | 0.5 | 1 | 2 | 5  | 10 | 20 | 30 | 40 | 10                  | 10                 | 0.1          | 0.2 | 0.5 |
| Dibromochloromethane          | 129                   | 127          | IS2 | Sur3   | 0.3                                | 0.5 | 1 | 2 | 5  | 10 | 20 | 30 | 40 | 10                  | 10                 | 0.1          | 0.2 | 0.5 |
| Dibromomethane                | 93                    | 95, 174      | IS1 | Sur0/1 | 0.3                                | 0.5 | 1 | 2 | 5  | 10 | 20 | 30 | 40 | 10                  | 10                 | 0.1          | 0.2 | 0.5 |
| Dichlorodifluoromethane       | 85                    | 87           | IS1 | Sur0/1 | 0.3                                | 0.5 | 1 | 2 | 5  | 10 | 20 | 30 | 40 | 10                  | 10                 | 0.15         | 0.3 | 0.5 |
| Dichlorofluoromethane         | 67                    | 69           | IS1 | Sur0/1 | 0.3                                | 0.5 | 1 | 2 | 5  | 10 | 20 | 30 | 40 | 10                  | 10                 | 0.1          | 0.2 | 0.5 |
| Diisopropyl ether (DIPE)      | 45                    | 87           | IS1 | Sur0/1 | 0.3                                | 0.5 | 1 | 2 | 5  | 10 | 20 | 30 | 40 | 10                  | 10                 | 0.11         | 0.2 | 0.5 |
| Ethyl Methacrylate            | 69                    | 99, 41       | IS2 | Sur3   | 0.3                                | 0.5 | 1 | 2 | 5  | 10 | 20 | 30 | 40 | 10                  | 10                 | 0.25         | 0.5 | 1   |
| Ethylbenzene                  | 91                    | 106          | IS2 | Sur3   | 0.3                                | 0.5 | 1 | 2 | 5  | 10 | 20 | 30 | 40 | 10                  | 10                 | 0.1          | 0.2 | 0.5 |
| Ethyl-tert-butyl ether (ETBE) | 59                    | 87           | IS1 | Sur0/1 | 0.3                                | 0.5 | 1 | 2 | 5  | 10 | 20 | 30 | 40 | 10                  | 10                 | 0.11         | 0.2 | 0.5 |
| Hexachlorobutadiene           | 225                   | 223, 227     | IS3 | Sur2   | 0.3                                | 0.5 | 1 | 2 | 5  | 10 | 20 | 30 | 40 | 10                  | 10                 | 0.22         | 0.3 | 0.5 |
| Iodomethane                   | 142                   | 127          | IS1 | Sur0/1 | 0.3                                | 0.5 | 1 | 2 | 5  | 10 | 20 | 30 | 40 | 10                  | 10                 | 0.15         | 0.3 | 0.5 |
| Isopropylbenzene              | 105                   | 120, 79, 103 | IS3 | Sur2   | 0.3                                | 0.5 | 1 | 2 | 5  | 10 | 20 | 30 | 40 | 10                  | 10                 | 0.1          | 0.2 | 0.5 |
| m/p-Xylenes                   | 91                    | 106          | IS2 | Sur3   | 0.6                                | 1   | 2 | 4 | 10 | 20 | 40 | 60 | 80 | 20                  | 20                 | 0.21         | 0.4 | 1   |
| Methylene chloride            | 49                    | 84, 86       | IS1 | Sur0/1 | 0.3                                | 0.5 | 1 | 2 | 5  | 10 | 20 | 30 | 40 | 10                  | 10                 | 0.25         | 0.5 | 1   |
| Methyl-t-butyl ether (MTBE)   | 73                    | 57           | IS1 | Sur0/1 | 0.3                                | 0.5 | 1 | 2 | 5  | 10 | 20 | 30 | 40 | 10                  | 10                 | 0.13         | 0.2 | 0.5 |
| Naphthalene                   | 128                   | 127          | IS3 | Sur2   | 0.3                                | 0.5 | 1 | 2 | 5  | 10 | 20 | 30 | 40 | 10                  | 10                 | 0.25         | 0.5 | 1   |
| n-Butylbenzene                | 91                    | 92, 134      | IS3 | Sur2   | 0.3                                | 0.5 | 1 | 2 | 5  | 10 | 20 | 30 | 40 | 10                  | 10                 | 0.17         | 0.2 | 0.5 |
| n-Propylbenzene               | 91                    | 65, 120      | IS3 | Sur2   | 0.3                                | 0.5 | 1 | 2 | 5  | 10 | 20 | 30 | 40 | 10                  | 10                 | 0.13         | 0.2 | 0.5 |
| o-Xylene                      | 91                    | 106          | IS2 | Sur3   | 0.3                                | 0.5 | 1 | 2 | 5  | 10 | 20 | 30 | 40 | 10                  | 10                 | 0.1          | 0.2 | 0.5 |
| p-Isopropyltoluene            | 119                   | 91, 134      | IS3 | Sur2   | 0.3                                | 0.5 | 1 | 2 | 5  | 10 | 20 | 30 | 40 | 10                  | 10                 | 0.14         | 0.2 | 0.5 |
| sec-Butylbenzene              | 105                   | 134          | IS3 | Sur2   | 0.3                                | 0.5 | 1 | 2 | 5  | 10 | 20 | 30 | 40 | 10                  | 10                 | 0.13         | 0.2 | 0.5 |

**Table 7: TYPICAL TARGET ANALYTE LIST FOR 25-ml PURGE**

| Analytes                     | CHARACTERISTIC ION(S) |               | IS  | SURR   | ICAL ANALYTE CONCENTRATIONS (µg/L) |     |   |    |    |    |     |     |     | ICV/DCC<br>EV(µg/L) | LCS/MS<br>EV(µg/L) | WATER (µg/L) |     |     |
|------------------------------|-----------------------|---------------|-----|--------|------------------------------------|-----|---|----|----|----|-----|-----|-----|---------------------|--------------------|--------------|-----|-----|
|                              | PRIMARY               | SECONDARY     |     |        | 1                                  | 2   | 3 | 4  | 5  | 6  | 7   | 8   | 9   |                     |                    | DL           | LOD | LOQ |
| Styrene                      | 104                   | 78, 103       | IS2 | Sur3   | 0.3                                | 0.5 | 1 | 2  | 5  | 10 | 20  | 30  | 40  | 10                  | 10                 | 0.1          | 0.2 | 0.5 |
| tert-Amylmethyl ether (TAME) | 87                    | 55,73         | IS1 | Sur0/1 | 0.3                                | 0.5 | 1 | 2  | 5  | 10 | 20  | 30  | 40  | 10                  | 10                 | 0.11         | 0.2 | 0.5 |
| tert-Butyl alcohol (TBA)     | 59                    | 41            | IS1 | Sur0/1 | 1.5                                | 2   | 5 | 10 | 25 | 50 | 100 | 150 | 200 | 50                  | 50                 | 2.5          | 5   | 10  |
| tert-Butylbenzene            | 134                   | 91, 119       | IS3 | Sur2   | 0.3                                | 0.5 | 1 | 2  | 5  | 10 | 20  | 30  | 40  | 10                  | 10                 | 0.13         | 0.2 | 0.5 |
| Tetrachloroethene            | 164                   | 129, 131, 166 | IS2 | Sur3   | 0.3                                | 0.5 | 1 | 2  | 5  | 10 | 20  | 30  | 40  | 10                  | 10                 | 0.15         | 0.2 | 0.5 |
| Toluene                      | 91                    | 92            | IS2 | Sur3   | 0.3                                | 0.5 | 1 | 2  | 5  | 10 | 20  | 30  | 40  | 10                  | 10                 | 0.1          | 0.2 | 0.5 |
| trans-1,2-Dichloroethene     | 61                    | 96, 98        | IS1 | Sur0/1 | 0.3                                | 0.5 | 1 | 2  | 5  | 10 | 20  | 30  | 40  | 10                  | 10                 | 0.1          | 0.2 | 0.5 |
| trans-1,3-Dichloropropene    | 75                    | 77, 39        | IS2 | Sur3   | 0.3                                | 0.5 | 1 | 2  | 5  | 10 | 20  | 30  | 40  | 10                  | 10                 | 0.11         | 0.2 | 0.5 |
| trans-1,4-Dichloro-2-butene  | 53                    | 88            | IS3 | Sur2   | 0.3                                | 0.5 | 1 | 2  | 5  | 10 | 20  | 30  | 40  | 10                  | 10                 | 0.5          | 1   | 2   |
| Trichloroethene              | 130                   | 97, 132, 95   | IS1 | Sur0/1 | 0.3                                | 0.5 | 1 | 2  | 5  | 10 | 20  | 30  | 40  | 10                  | 10                 | 0.1          | 0.2 | 0.5 |
| Trichlorofluoromethane       | 101                   | 103           | IS1 | Sur0/1 | 0.3                                | 0.5 | 1 | 2  | 5  | 10 | 20  | 30  | 40  | 10                  | 10                 | 0.15         | 0.3 | 0.5 |
| Vinyl acetate                | 43                    | 86            | IS1 | Sur0/1 | 0.3                                | 0.5 | 1 | 2  | 5  | 10 | 20  | 30  | 40  | 10                  | 10                 | 0.25         | 0.5 | 1   |
| Vinyl chloride               | 62                    | 64            | IS1 | Sur0/1 | 0.3                                | 0.5 | 1 | 2  | 5  | 10 | 20  | 30  | 40  | 10                  | 10                 | 0.12         | 0.2 | 0.5 |
| Dibromofluoromethane (Sur0)  | 111                   | 113, 192      | IS1 |        | 0.3                                | 0.5 | 1 | 2  | 5  | 10 | 20  | 30  | 40  | 10                  | 10                 | 0.5          | 1   | 2   |
| 1,2-Dichloroethane-d4 (Sur1) | 65                    | 102           | IS1 |        | 0.3                                | 0.5 | 1 | 2  | 5  | 10 | 20  | 30  | 40  | 10                  | 10                 | 0.5          | 1   | 2   |
| 4-Bromofluorobenzene (Sur2)  | 95                    | 174, 176      | IS3 |        | 0.3                                | 0.5 | 1 | 2  | 5  | 10 | 20  | 30  | 40  | 10                  | 10                 | 0.5          | 1   | 2   |
| Toluene-D8 (Sur3)            | 98                    | 100           | IS2 |        | 0.3                                | 0.5 | 1 | 2  | 5  | 10 | 20  | 30  | 40  | 10                  | 10                 | 0.5          | 1   | 2   |
| 1,4-Difluorobenzene (IS1)    | 114                   | 88            |     |        |                                    |     |   |    |    |    |     |     |     |                     |                    |              |     |     |
| Chlorobenzene-d5 (IS2)       | 117                   | 82, 119       |     |        |                                    |     |   |    |    |    |     |     |     |                     |                    |              |     |     |
| 1,2-Dichlorobenzene-d4 (IS3) | 152                   | 150           |     |        |                                    |     |   |    |    |    |     |     |     |                     |                    |              |     |     |

Note: Since retention time of Dibromofluoromethane (Sur0) and 1,2-Dichloroethane-d4 (Sur1) is too close (~43 sec) hence, Dibromofluoromethane (Sur0) is only used when required by the project.

**Figure 1:**

**PEAK EVALUATION TECHNIQUES**

---

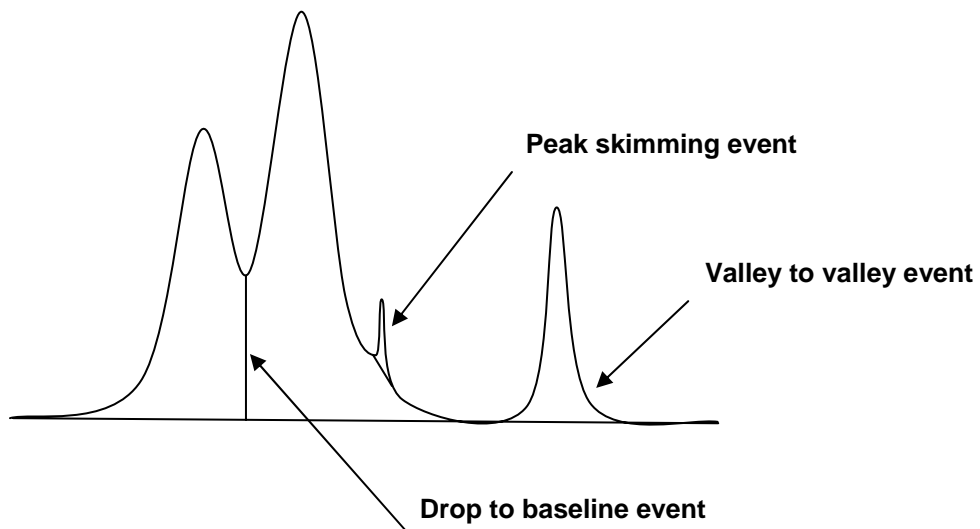

Figure 2:

TYPICAL CHROMATOGRAM

Quantitation Report

Data File : D:\HPCHEM\1\DATA\11E25\REC395.D  
Acq On : 25 May 2011 1:40 pm  
Sample : IVO67E2402 10ppb  
Misc : 10ppb 8260/50ppb KET-ACR-ACN-TBA  
MS Integration Params: LSCINT1.P  
Quant Time: May 25 16:32 2011

Vial: 2  
Operator: AS  
Inst : TO67  
Multiplr: 1.00

Quant Results File: VO67E24.RES

Method : D:\HPCHEM\1\METHODS\VO67E24.M (RTE Integrator)  
Title : METHOD 8260B 4.0  
Last Update : Wed May 25 16:26:28 2011  
Response via : Initial Calibration

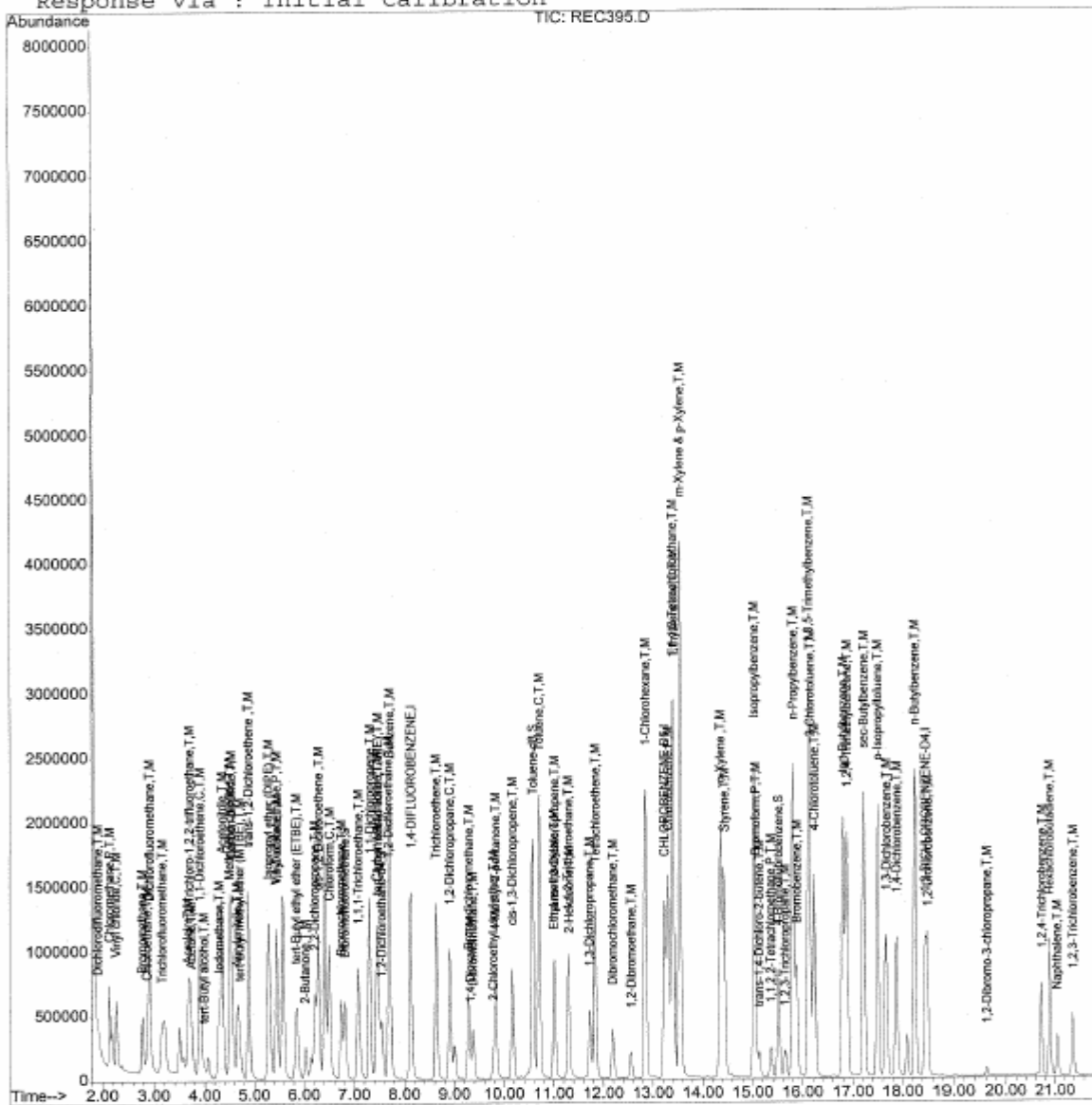

Figure 3:

TYPICAL ICAL SUMMARY

INITIAL\_CALIBRATION - RELATIVE\_RESPONSE\_FACTOR

Instrument ID :03  
Beginning DateTime :03/12/13 07:57  
Spike Units :PPB  
IC File :RCB023

Column Spec :ZB-624 ID :0.25MM  
Ending DateTime :03/12/13 12:58  
HPChem Method :V003C12

| M_IDX | Parameters                            | .3<br>RCB018 | .5<br>RCB019 | 1<br>RCB020 | 2<br>RCB021 | 5<br>RCB022 | 10<br>RCB023 | 20<br>RCB024 | 30<br>RCB025 | 50<br>RCB026 | 100<br>RCB027 | Av_RRF | %_RSD | Av_Rt_M |
|-------|---------------------------------------|--------------|--------------|-------------|-------------|-------------|--------------|--------------|--------------|--------------|---------------|--------|-------|---------|
| 1     | 1,4-DIFLUOROENZENE                    | 1            | 1            | 1           | 1           | 1           | 1            | 1            | 1            | 1            | 1             | 1      | 0     | 13.1167 |
| 2     | Chlorotrifluoroethylene               |              |              |             |             |             |              |              |              |              |               | 0.000  | 0.00  | 0.0000  |
| 3     | Dichlorodifluoromethane               | 0.312        | 0.311        | 0.326       | 0.327       | 0.302       | 0.284        | 0.298        | 0.281        | 0.271        | 0.265         | 0.298  | 7.35  | 4.0527  |
| 4     | Chloromethane                         | 0.497        | 0.479        | 0.499       | 0.498       | 0.449       | 0.423        | 0.434        | 0.414        | 0.395        | 0.379         | 0.447  | 10.02 | 4.5516  |
| 5     | Vinyl chloride                        | 0.295        | 0.288        | 0.315       | 0.308       | 0.286       | 0.271        | 0.286        | 0.277        | 0.270        | 0.273         | 0.287  | 5.39  | 4.8866  |
| 6     | 2-Chloro-1,1,1-trifluoroethane        |              |              |             |             |             |              |              |              |              |               | 0.000  | 0.00  | 0.0000  |
| 7     | Bromomethane                          | 0.307        | 0.306        | 0.320       | 0.311       | 0.275       | 0.265        | 0.267        | 0.247        | 0.210        |               | 0.279  | 12.91 | 5.7735  |
| 8     | Chloroethane                          | 0.209        | 0.223        | 0.239       | 0.233       | 0.210       | 0.202        | 0.209        | 0.197        | 0.184        | 0.165         | 0.207  | 10.58 | 6.0466  |
| 9     | Dichlorofluoromethane                 | 0.670        | 0.653        | 0.680       | 0.650       | 0.648       | 0.592        | 0.632        | 0.621        | 0.635        | 0.625         | 0.641  | 3.96  | 6.5916  |
| 10    | Trichlorofluoromethane                | 0.321        | 0.351        | 0.385       | 0.402       | 0.365       | 0.363        | 0.384        | 0.376        | 0.364        | 0.363         | 0.367  | 5.95  | 6.6749  |
| 5 11  | Acrolein                              | 0.012        | 0.010        | 0.011       | 0.011       | 0.012       | 0.013        | 0.013        | 0.013        | 0.013        | 0.013         | 0.012  | 9.23  | 7.7679  |
| 12    | 1,1,2-Trichloro-1,2,2-trifluoroethane | 0.214        | 0.199        | 0.207       | 0.193       | 0.190       | 0.173        | 0.180        | 0.176        | 0.185        | 0.180         | 0.190  | 7.16  | 7.8901  |
| 13    | 1,1-Dichloroethene                    | 0.613        | 0.612        | 0.620       | 0.579       | 0.570       | 0.534        | 0.548        | 0.523        | 0.543        | 0.514         | 0.566  | 6.97  | 7.9392  |
| 5 14  | Acetone                               |              |              | 0.045       | 0.035       | 0.032       | 0.031        | 0.029        | 0.027        | 0.029        | 0.028         | 0.032  | 18.18 | 8.1020  |
| 15    | Iodomethane                           | 0.553        | 0.519        | 0.566       | 0.525       | 0.512       | 0.471        | 0.490        | 0.476        | 0.484        | 0.486         | 0.508  | 6.41  | 8.3338  |
| 16    | Carbon disulfide                      | 1.259        | 1.220        | 1.291       | 1.367       | 1.204       | 1.194        | 1.218        | 1.179        | 1.183        | 1.151         | 1.227  | 5.20  | 8.4588  |
| 17    | Methyl acetate                        |              |              |             |             |             |              |              |              |              |               | 0.000  | 0.00  | 0.0000  |
| 18    | Methylene chloride                    |              |              | 0.548       | 0.484       | 0.450       | 0.419        | 0.422        | 0.397        | 0.422        | 0.401         | 0.443  | 11.51 | 9.0085  |
| 5 19  | tert-Butyl alcohol                    | 0.009        | 0.009        | 0.011       | 0.010       | 0.010       | 0.009        | 0.010        | 0.009        | 0.010        | 0.009         | 0.010  | 6.11  | 9.2093  |
| 20    | tert-Butyl methyl ether (MTBE)        | 0.430        | 0.405        | 0.440       | 0.420       | 0.409       | 0.367        | 0.381        | 0.371        | 0.404        | 0.374         | 0.400  | 6.43  | 9.4267  |
| 21    | trans-1,2-Dichloroethene              | 0.681        | 0.638        | 0.664       | 0.629       | 0.618       | 0.585        | 0.584        | 0.553        | 0.577        | 0.535         | 0.606  | 7.83  | 9.4834  |
| 5 22  | Acrylonitrile                         | 0.036        | 0.036        | 0.041       | 0.040       | 0.038       | 0.039        | 0.037        | 0.037        | 0.038        | 0.036         | 0.038  | 5.13  | 9.5161  |
| 23    | Isopropyl ether (DIPE)                | 1.387        | 1.263        | 1.335       | 1.285       | 1.234       | 1.171        | 1.151        | 1.110        | 1.121        | 1.024         | 1.208  | 9.29  | 10.2472 |
| 24    | 1,1-Dichloroethane                    | 0.768        | 0.739        | 0.749       | 0.730       | 0.706       | 0.676        | 0.668        | 0.644        | 0.653        | 0.605         | 0.694  | 7.62  | 10.2785 |
| 25    | Vinyl acetate                         |              | 0.332        | 0.283       | 0.324       | 0.337       | 0.355        | 0.379        | 0.413        | 0.347        | 0.317         | 0.343  | 10.92 | 10.3003 |
| 26    | tert-Butyl ethyl ether (ETBE)         | 0.796        | 0.755        | 0.728       | 0.707       | 0.718       | 0.694        | 0.681        | 0.696        | 0.732        | 0.705         | 0.721  | 4.69  | 10.8667 |
| 27    | 2,2-Dichloropropane                   | 0.395        | 0.372        | 0.378       | 0.353       | 0.339       | 0.345        | 0.323        | 0.310        | 0.300        | 0.263         | 0.338  | 11.78 | 11.2345 |
| 5 28  | 2-Butanone                            | 0.083        | 0.072        | 0.068       | 0.069       | 0.064       | 0.064        | 0.055        | 0.056        | 0.058        | 0.053         | 0.064  | 14.51 | 11.2761 |
| 29    | cis-1,2-Dichloroethene                | 0.469        | 0.440        | 0.442       | 0.430       | 0.415       | 0.405        | 0.384        | 0.379        | 0.390        | 0.365         | 0.412  | 8.05  | 11.2687 |
| 5 30  | 2-Butanol                             |              |              |             |             |             |              |              |              |              |               | 0.000  | 0.00  | 0.0000  |
| 31    | Bromochloromethane                    | 0.307        | 0.309        | 0.315       | 0.309       | 0.309       | 0.274        | 0.277        | 0.276        | 0.288        | 0.257         | 0.292  | 6.89  | 11.6797 |
| 32    | Tetrahydrofuran                       |              |              | 0.048       | 0.045       | 0.037       | 0.034        | 0.033        | 0.036        | 0.036        | 0.034         | 0.038  | 13.93 | 11.7372 |
| 33    | Chloroform                            | 0.705        | 0.690        | 0.687       | 0.691       | 0.672       | 0.607        | 0.605        | 0.606        | 0.620        | 0.579         | 0.646  | 7.24  | 11.7705 |
| 34    | Dibromofluoromethane                  | 0.326        | 0.367        | 0.356       | 0.342       | 0.340       | 0.327        | 0.311        | 0.315        | 0.311        | 0.294         | 0.329  | 6.83  | 12.0326 |
| 35    | 1,1,1-Trichloroethane                 | 0.523        | 0.515        | 0.500       | 0.484       | 0.512       | 0.471        | 0.477        | 0.472        | 0.470        | 0.435         | 0.486  | 5.50  | 12.0386 |
| 36    | Cyclohexane                           |              |              |             |             |             |              |              |              |              |               | 0.000  | 0.00  | 0.0000  |
| 37    | 1,1-Dichloropropene                   | 0.209        | 0.194        | 0.192       | 0.189       | 0.183       | 0.178        | 0.181        | 0.182        | 0.174        | 0.159         | 0.184  | 7.23  | 12.2738 |
| 38    | Carbon tetrachloride                  | 0.467        | 0.452        | 0.446       | 0.423       | 0.441       | 0.427        | 0.429        | 0.426        | 0.426        | 0.403         | 0.434  | 4.16  | 12.2857 |
| 39    | 1,2-Dichloroethane-d4                 | 0.270        | 0.266        | 0.275       | 0.269       | 0.258       | 0.251        | 0.225        |              |              |               | 0.259  | 6.60  | 12.5581 |
| 40    | Benzene                               | 1.724        | 1.622        | 1.501       | 1.421       | 1.497       | 1.348        | 1.382        | 1.392        | 1.393        |               | 1.476  | 8.50  | 12.6150 |
| 41    | tert-Amyl methyl ether (TAME)         | 0.100        | 0.103        | 0.107       | 0.100       | 0.109       | 0.098        | 0.097        | 0.102        | 0.105        | 0.098         | 0.102  | 4.11  | 12.6595 |
| 42    | 1,2-Dichloroethane                    | 0.299        | 0.308        | 0.290       | 0.294       | 0.303       | 0.287        | 0.279        | 0.277        | 0.287        | 0.256         | 0.288  | 5.20  | 12.6729 |
| 43    | Trichloroethene                       | 0.428        | 0.404        | 0.405       | 0.389       | 0.419       | 0.382        | 0.382        | 0.375        | 0.400        | 0.366         | 0.395  | 4.98  | 13.5291 |
| 44    | Methylcyclohexane                     |              |              |             |             |             |              |              |              |              |               | 0.000  | 0.00  | 0.0000  |
| 45    | 1,2-Dichloropropane                   | 0.387        | 0.398        | 0.375       | 0.376       | 0.407       | 0.377        | 0.381        | 0.361        | 0.376        | 0.342         | 0.378  | 4.76  | 13.8776 |
| 20 46 | 1,4-Dioxane                           | 0.001        | 0.001        | 0.001       | 0.001       | 0.001       | 0.001        | 0.001        | 0.001        | 0.001        | 0.001         | 0.001  | 9.47  | 14.0562 |
| 47    | Dibromomethane                        | 0.163        | 0.146        | 0.158       | 0.146       | 0.166       | 0.142        | 0.149        | 0.144        | 0.158        | 0.145         | 0.152  | 5.80  | 14.0935 |
| 48    | Bromodichloromethane                  | 0.438        | 0.407        | 0.437       | 0.429       | 0.470       | 0.419        | 0.416        | 0.430        | 0.448        | 0.413         | 0.431  | 4.33  | 14.2617 |



Figure 3 (cont.):

TYPICAL ICAL SUMMARY

|    |                             |       |       |       |       |       |       |       |       |       |       |       |       |         |
|----|-----------------------------|-------|-------|-------|-------|-------|-------|-------|-------|-------|-------|-------|-------|---------|
| 49 | 2-Chloroethyl vinyl ether   | ----- | 0.052 | 0.053 | 0.059 | 0.064 | 0.062 | 0.064 | 0.067 | 0.077 | 0.073 | 0.063 | 13.09 | 14.5606 |
| 50 | cis-1,3-Dichloropropene     | 0.511 | 0.509 | 0.493 | 0.489 | 0.553 | 0.509 | 0.513 | 0.510 | 0.537 | 0.492 | 0.512 | 3.91  | 14.8291 |
| 51 | 4-Methyl-2-pentanone        | 0.182 | 0.169 | 0.170 | 0.164 | 0.180 | 0.168 | 0.154 | 0.160 | 0.170 | 0.144 | 0.166 | 6.86  | 14.9541 |
| 52 | CHLOROBENZENE-D5            | 1     | 1     | 1     | 1     | 1     | 1     | 1     | 1     | 1     | 1     | 1     | 0     | 17.1073 |
| 53 | Toluene-d8                  | 1.471 | 1.484 | 1.407 | 1.468 | 1.417 | 1.414 | 1.426 | 1.350 | 1.404 | ----- | 1.427 | 2.94  | 15.1712 |
| 54 | Toluene                     | 1.975 | 1.822 | 1.622 | 1.764 | 1.814 | 1.638 | 1.732 | 1.646 | 1.710 | ----- | 1.747 | 6.46  | 15.2622 |
| 55 | Ethyl methacrylate          | 0.274 | 0.248 | 0.237 | 0.247 | 0.287 | 0.268 | 0.263 | 0.270 | 0.286 | 0.266 | 0.264 | 6.15  | 15.5111 |
| 56 | trans-1,3-Dichloropropene   | 0.383 | 0.368 | 0.358 | 0.376 | 0.420 | 0.392 | 0.406 | 0.404 | 0.429 | 0.403 | 0.394 | 5.77  | 15.5483 |
| 57 | 1,1,2-Trichloroethane       | 0.222 | 0.209 | 0.198 | 0.196 | 0.213 | 0.196 | 0.195 | 0.206 | 0.217 | 0.201 | 0.205 | 4.79  | 15.8267 |
| 58 | Tetrachloroethene           | 0.438 | 0.389 | 0.368 | 0.385 | 0.382 | 0.355 | 0.371 | 0.366 | 0.383 | 0.352 | 0.379 | 6.42  | 15.9995 |
| 59 | 2-Hexanone                  | 0.119 | 0.137 | 0.116 | 0.121 | 0.117 | 0.125 | 0.112 | 0.121 | 0.125 | 0.106 | 0.120 | 6.87  | 16.0248 |
| 60 | 1,3-Dichloropropane         | 0.416 | 0.397 | 0.392 | 0.417 | 0.411 | 0.384 | 0.385 | 0.389 | 0.415 | 0.377 | 0.398 | 3.79  | 16.0531 |
| 61 | Dibromochloromethane        | 0.252 | 0.234 | 0.233 | 0.261 | 0.259 | 0.256 | 0.262 | 0.267 | 0.287 | 0.268 | 0.258 | 6.22  | 16.3941 |
| 62 | 1,2-Dibromoethane           | 0.207 | 0.208 | 0.195 | 0.197 | 0.212 | 0.193 | 0.202 | 0.205 | 0.224 | 0.208 | 0.205 | 4.47  | 16.5847 |
| 63 | 1-Chlorohexane              | 0.897 | 0.862 | 0.785 | 0.803 | 0.835 | 0.761 | 0.806 | 0.779 | 0.829 | 0.757 | 0.811 | 5.53  | 16.9495 |
| 64 | Chlorobenzene               | 1.152 | 1.065 | 0.937 | 0.954 | 0.990 | 0.958 | 0.962 | 0.991 | 1.007 | 0.911 | 0.993 | 7.08  | 17.1475 |
| 65 | Ethylbenzene                | 2.251 | 2.178 | 2.021 | 1.994 | 2.182 | 1.965 | 2.014 | 2.014 | 1.839 | ----- | 2.051 | 6.29  | 17.1930 |
| 66 | 1,1,1,2-Tetrachloroethane   | 0.319 | 0.317 | 0.311 | 0.307 | 0.333 | 0.304 | 0.308 | 0.319 | 0.318 | 0.294 | 0.313 | 3.37  | 17.2264 |
| 67 | m-Xylene & p-Xylene         | 1.713 | 1.626 | 1.515 | 1.469 | 1.497 | 1.439 | 1.490 | 1.387 | ----- | ----- | 1.517 | 6.90  | 17.3227 |
| 68 | o-Xylene                    | 1.694 | 1.653 | 1.478 | 1.477 | 1.519 | 1.428 | 1.437 | 1.428 | 1.440 | ----- | 1.506 | 6.65  | 17.8581 |
| 69 | Styrene                     | 1.028 | 1.012 | 0.971 | 0.933 | 1.027 | 0.971 | 0.981 | 0.978 | 0.998 | 0.874 | 0.977 | 4.73  | 17.8787 |
| 70 | 1,2-DICHLOROBENZENE-D4      | 1     | 1     | 1     | 1     | 1     | 1     | 1     | 1     | 1     | 1     | 1     | 0     | 20.6245 |
| 71 | Bromoform                   | 0.330 | 0.326 | 0.329 | 0.333 | 0.339 | 0.334 | 0.362 | 0.385 | 0.425 | 0.401 | 0.356 | 9.92  | 18.2613 |
| 72 | Isopropylbenzene            | 5.562 | 5.517 | 5.180 | 5.026 | 5.022 | 4.609 | 5.010 | 5.013 | 5.337 | ----- | 5.142 | 5.76  | 18.2767 |
| 73 | 4-Bromofluorobenzene        | 1.603 | 1.546 | 1.384 | 1.356 | 1.335 | 1.258 | 1.308 | 1.333 | 1.419 | 1.324 | 1.386 | 7.83  | 18.5621 |
| 74 | 1,1,2,2-Tetrachloroethane   | 0.746 | 0.756 | 0.716 | 0.675 | 0.696 | 0.618 | 0.665 | 0.707 | 0.749 | 0.704 | 0.703 | 6.08  | 18.7036 |
| 75 | trans-1,4-Dichloro-2-butene | 0.187 | 0.180 | 0.176 | 0.186 | 0.198 | 0.177 | 0.197 | 0.205 | 0.223 | 0.201 | 0.193 | 7.69  | 18.7438 |
| 76 | n-Propylbenzene             | 8.651 | 8.030 | 7.852 | 7.211 | 7.500 | 6.892 | 7.592 | 7.274 | ----- | ----- | 7.625 | 7.21  | 18.7857 |
| 77 | 1,2,3-Trichloropropane      | 0.177 | 0.170 | 0.160 | 0.153 | 0.158 | 0.140 | 0.147 | 0.149 | 0.157 | 0.138 | 0.155 | 7.93  | 18.8019 |
| 78 | Bromobenzene                | 1.165 | 1.071 | 1.055 | 1.014 | 1.052 | 0.931 | 0.983 | 1.022 | 1.109 | 1.010 | 1.041 | 6.31  | 18.8227 |
| 79 | 1,3,5-Trimethylbenzene      | 4.694 | 4.553 | 4.332 | 4.080 | 4.256 | 3.733 | 4.106 | 4.107 | 4.355 | 3.299 | 4.151 | 9.67  | 18.9612 |
| 80 | 2-Chlorotoluene             | 5.150 | 4.552 | 4.413 | 4.224 | 4.372 | 3.923 | 4.126 | 4.108 | 4.517 | 3.691 | 4.308 | 9.28  | 18.9999 |
| 81 | 4-Chlorotoluene             | 4.441 | 3.866 | 3.719 | 3.646 | 3.838 | 3.506 | 3.604 | 3.728 | 4.047 | 3.296 | 3.769 | 8.31  | 19.1265 |
| 82 | tert-Butylbenzene           | 1.011 | 0.999 | 0.944 | 0.893 | 0.936 | 0.837 | 0.894 | 0.889 | 0.955 | 0.865 | 0.922 | 6.14  | 19.4213 |
| 83 | 1,2,4-Trimethylbenzene      | 4.627 | 4.271 | 3.973 | 4.095 | 4.026 | 3.564 | 3.677 | 3.874 | 4.208 | 3.401 | 3.972 | 9.12  | 19.4794 |
| 84 | sec-Butylbenzene            | 6.845 | 6.467 | 6.537 | 6.165 | 6.138 | 5.570 | 5.934 | 5.860 | 6.013 | ----- | 6.170 | 6.32  | 19.6962 |
| 85 | p-Isopropyltoluene          | 4.982 | 4.670 | 4.483 | 4.208 | 4.407 | 4.011 | 4.268 | 4.060 | 4.454 | ----- | 4.394 | 6.93  | 19.8402 |
| 86 | 1,3-Dichlorobenzene         | 2.358 | 2.168 | 2.115 | 2.002 | 2.047 | 1.927 | 2.037 | 1.985 | 2.204 | 2.008 | 2.085 | 6.15  | 19.9961 |
| 87 | 1,4-Dichlorobenzene         | 2.379 | 2.019 | 1.958 | 1.903 | 1.942 | 1.756 | 1.873 | 1.837 | 2.027 | 1.854 | 1.955 | 8.73  | 20.1063 |
| 88 | n-Butylbenzene              | 5.550 | 4.899 | 5.079 | 4.650 | 4.817 | 4.593 | 4.886 | 4.619 | 4.980 | ----- | 4.897 | 6.06  | 20.3928 |
| 89 | 1,2-Dichlorobenzene         | 1.816 | 1.636 | 1.646 | 1.560 | 1.576 | 1.448 | 1.505 | 1.471 | 1.578 | 1.464 | 1.570 | 7.08  | 20.6528 |
| 90 | 1,2-Dibromo-3-chloropropane | 0.063 | 0.069 | 0.073 | 0.072 | 0.076 | 0.068 | 0.073 | 0.073 | 0.078 | 0.074 | 0.072 | 6.04  | 21.7696 |
| 91 | 1,2,4-Trichlorobenzene      | 0.972 | 0.844 | 0.786 | 0.841 | 0.831 | 0.798 | 0.763 | 0.733 | 0.817 | 0.766 | 0.815 | 8.11  | 23.0070 |
| 92 | Hexachlorobutadiene         | ----- | 0.740 | 0.722 | 0.700 | 0.678 | 0.604 | 0.560 | 0.503 | 0.559 | 0.527 | 0.621 | 14.43 | 23.1360 |
| 93 | Naphthalene                 | 1.249 | 1.099 | 1.013 | 1.042 | 1.036 | 0.961 | 0.917 | 0.843 | 0.957 | 0.895 | 1.001 | 11.58 | 23.4983 |
| 94 | 1,2,3-Trichlorobenzene      | 0.700 | 0.631 | 0.619 | 0.614 | 0.617 | 0.556 | 0.499 | 0.460 | 0.505 | 0.476 | 0.568 | 14.08 | 23.9168 |

Spike Amount = Nominal Amount \* M  
Ave\_%RSD : 7.5                      Max\_%RSD : 18.2

Use Least Square Linear Regression with weighting factor of inverse concentration for comps with %\_RSD > 15  
Resp\_Ratio = x0 + x1 \* Amt\_Ratio

| IDX | Parameter | x0      | x1      | CCF    |
|-----|-----------|---------|---------|--------|
| 14  | Acetone   | 0.00872 | 0.02772 | 0.9996 |

**Figure 4: TYPICAL INSTRUMENT PERFORMANCE CHECK (TUNING)**

BFB

Data File : D:\HPCHEM\1\DATA\11D07\RDB064.D Vial: 2  
 Acq On : 7 Apr 2011 7:43 pm Operator: MW  
 Sample : BFB03D04 Inst : TO03  
 Misc : T/CHECK Multiplr: 1.00  
 MS Integration Params: 524INT.P  
 Method : D:\HPCHEM\1\METHODS\VO03D07.M (RTE Integrator)  
 Title : METHOD 8260 25mL

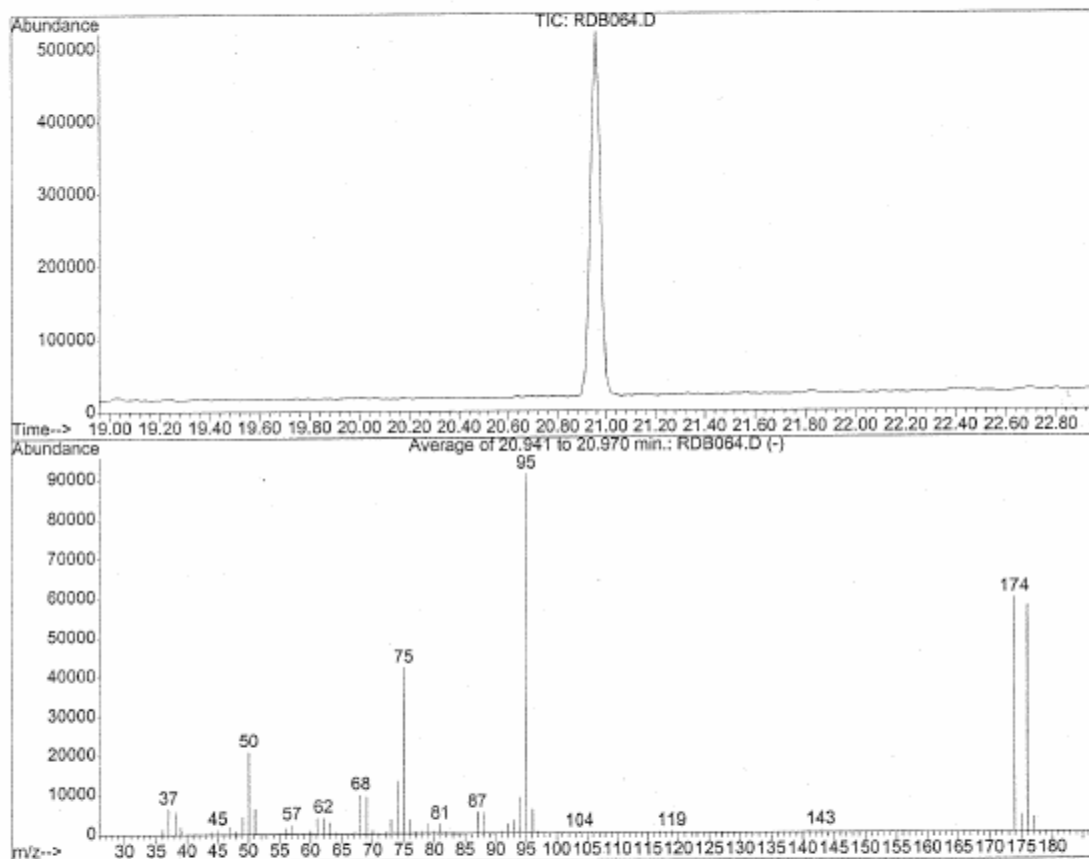

AutoFind: Scans 1163, 1164, 1165; Background Corrected with Scan 1156

| Target Mass | Rel. to Mass | Lower Limit% | Upper Limit% | Rel. Abn% | Raw Abn | Result Pass/Fail |
|-------------|--------------|--------------|--------------|-----------|---------|------------------|
| 50          | 95           | 15           | 40           | 22.9      | 20916   | PASS             |
| 75          | 95           | 30           | 60           | 46.4      | 42347   | PASS             |
| 95          | 95           | 100          | 100          | 100.0     | 91301   | PASS             |
| 96          | 95           | 5            | 9            | 6.6       | 6055    | PASS             |
| 173         | 174          | 0.00         | 2            | 0.0       | 0       | PASS             |
| 174         | 95           | 50           | 100          | 65.3      | 59619   | PASS             |
| 175         | 174          | 5            | 9            | 7.4       | 4406    | PASS             |
| 176         | 174          | 95           | 101          | 96.7      | 57635   | PASS             |
| 177         | 176          | 5            | 9            | 6.7       | 3884    | PASS             |



**Figure 6: TYPICAL INTERNAL STANDARD AREA AND RETENTION TIME SUMMARY**

8A  
 VOLATILE INTERNAL STANDARD AREA AND RT SUMMARY

|                                    |                               |
|------------------------------------|-------------------------------|
| Lab Name : EMAX INC.               | Project : CLEAN WATER PROJECT |
| Lab Code : EMXT                    | SDG No. : YMNNN               |
| Lab File ID : RDC168               | Date Analyzed : 04/09/14      |
| Instrument ID: 67                  | Time Analyzed : 18:54         |
| GC Column : RTX502.2ID:0.25mm (mm) | Heated Purge : No             |

|                  | IS1 (DFB) |      | IS2 (CBZ) |       | IS3 (DCB) |       |
|------------------|-----------|------|-----------|-------|-----------|-------|
|                  | AREA #    | RT # | AREA #    | RT #  | AREA #    | RT #  |
| 12 HOUR STD      | 1321331   | 8.08 | 1022177   | 13.17 | 321226    | 18.40 |
| UPPER LIMIT      | 2642662   | 8.58 | 2044354   | 13.67 | 642452    | 18.90 |
| LOWER LIMIT      | 660666    | 7.58 | 511089    | 12.67 | 160613    | 17.90 |
| SAMPLE ID        |           |      |           |       |           |       |
| 1 VSTD010        | 1155410   | 8.07 | 908594    | 13.15 | 276831    | 18.38 |
| 2 MBLK1W         | 1259632   | 8.07 | 956984    | 13.15 | 261376    | 18.38 |
| 3 LCS1W          | 1216852   | 8.07 | 957974    | 13.15 | 290568    | 18.38 |
| 4 LCD1W          | 1262335   | 8.07 | 983468    | 13.15 | 300886    | 18.38 |
| 5 XXX-59GW001    | 1202358   | 8.07 | 934767    | 13.16 | 277693    | 18.38 |
| 6 XXX-59GW001MS  | 1216852   | 8.07 | 957974    | 13.17 | 290568    | 18.38 |
| 7 XXX-59GW001MSD | 1262335   | 8.07 | 983468    | 13.17 | 300886    | 18.38 |

IS1 (DFB) = 1,4-Difluorobenzene  
 IS2 (CBZ) = Chlorobenzene-d5  
 IS3 (DCB) = 1,2-Dichlorobenzene-d4

AREA UPPER LIMIT = + 100% of internal standard area  
 AREA LOWER LIMIT = - 50% of internal standard area  
 RT UPPER LIMIT = + 0.5 minutes (30 sec) of internal standard RT  
 RT LOWER LIMIT = - 0.5 minutes (30 sec) of internal standard RT

# Column used to flag internal standard area values with an asterisk  
 \* Values outside of QC limits.

Figure 7:

TYPICAL SAMPLE RESULT SUMMARY

METHOD SW5030C/8260B  
 VOLATILE ORGANICS BY GC/MS

```

=====
Client      : XYZ INC.                      Date Collected: 04/28/14
Project     : CLEAN WATER PROJECT          Date Received: 04/29/14
Batch No.   : YMNNN                        Date Extracted: 04/29/14 16:55
Sample ID:  : XX-59XX001                   Date Analyzed: 04/29/14 16:55
Lab Samp ID: MNNN-02                       Dilution Factor: 1
Lab File ID: RDC534                         Matrix          : WATER
Ext Btch ID: VO67D21                       % Moisture     : NA
Calib. Ref.: RDC168                         Instrument ID   : 67
=====
  
```

| PARAMETERS                         | RESULTS<br>(ug/L) | LOQ<br>(ug/L) | DL<br>(ug/L) | LOD<br>(ug/L) |
|------------------------------------|-------------------|---------------|--------------|---------------|
| BENZENE                            | 0.11J             | 1.0           | 0.10         | 0.20          |
| BROMODICHLOROMETHANE               | ND                | 1.0           | 0.10         | 0.20          |
| BROMOFORM                          | 1.5               | 1.0           | 0.15         | 0.30          |
| BROMOMETHANE                       | ND                | 1.0           | 0.16         | 0.30          |
| CARBON TETRACHLORIDE               | ND                | 1.0           | 0.10         | 0.20          |
| CHLORO BENZENE                     | ND                | 1.0           | 0.10         | 0.20          |
| CHLOROETHANE                       | ND                | 1.0           | 0.27         | 0.30          |
| CHLOROFORM                         | ND                | 1.0           | 0.10         | 0.20          |
| CHLOROMETHANE                      | ND                | 2.0           | 0.15         | 0.30          |
| DIBROMOCHLOROMETHANE               | 0.20J             | 1.0           | 0.10         | 0.20          |
| 1,2-DICHLORO BENZENE               | ND                | 1.0           | 0.10         | 0.20          |
| 1,3-DICHLORO BENZENE               | ND                | 1.0           | 0.11         | 0.20          |
| 1,4-DICHLORO BENZENE               | ND                | 1.0           | 0.10         | 0.20          |
| DICHLORODIFLUOROMETHANE (FREON 12) | ND                | 1.0           | 0.15         | 0.30          |
| 1,1-DICHLOROETHANE                 | ND                | 1.0           | 0.10         | 0.20          |
| 1,2-DICHLOROETHANE                 | ND                | 1.0           | 0.10         | 0.20          |
| 1,1-DICHLOROETHENE                 | ND                | 1.0           | 0.10         | 0.20          |
| 1,2-DICHLOROETHENE (TOTAL)         | 0.30J             | 1.0           | 0.10         | 0.20          |
| 1,2-DICHLOROPROPANE                | ND                | 1.0           | 0.10         | 0.20          |
| TRANS-1,3-DICHLOROPROPENE          | ND                | 1.0           | 0.11         | 0.20          |
| CIS-1,3-DICHLOROPROPENE            | ND                | 1.0           | 0.10         | 0.20          |
| ETHYLBENZENE                       | ND                | 1.0           | 0.10         | 0.20          |
| METHYLENE CHLORIDE                 | ND                | 5.0           | 0.25         | 0.50          |
| 1,1,2,2-TETRACHLOROETHANE          | ND                | 1.0           | 0.11         | 0.20          |
| TETRACHLOROETHENE                  | 0.19J             | 1.0           | 0.15         | 0.20          |
| TOLUENE                            | 62                | 1.0           | 0.10         | 0.20          |
| 1,1,1-TRICHLOROETHANE              | ND                | 1.0           | 0.10         | 0.20          |
| 1,1,2-TRICHLOROETHANE              | ND                | 1.0           | 0.10         | 0.20          |
| TRICHLOROFLUOROMETHANE (FREON 11)  | ND                | 1.0           | 0.15         | 0.30          |
| TRICHLOROETHENE                    | 14                | 1.0           | 0.10         | 0.20          |
| VINYL CHLORIDE                     | ND                | 2.0           | 0.12         | 0.20          |
| XYLENES (TOTAL)                    | ND                | 1.0           | 0.10         | 0.50          |

| SURROGATE PARAMETERS  | RESULTS | SPK_AMT | % RECOVERY | QC LIMIT |
|-----------------------|---------|---------|------------|----------|
| 1,2-DICHLOROETHANE-D4 | 8.44    | 10.00   | 84.4       | 70-120   |
| 4-BROMOFLUOROBENZENE  | 9.41    | 10.00   | 94.1       | 75-120   |
| TOLUENE-D8            | 10.3    | 10.00   | 103        | 85-120   |
| DIBROMOFLUOROMETHANE  | 9.95    | 10.00   | 99.5       | 85-115   |

Figure 8:

## TYPICAL LCS/LCSD SUMMARY

EMAX QUALITY CONTROL DATA  
LCS/LCD ANALYSIS

CLIENT: XYZ INC.  
PROJECT: CLEAN WATER PROJECT  
BATCH NO.: YMMNN  
METHOD: SW5030C/8260B

=====

MATRIX: WATER % MOISTURE: NA  
DILUTION FACTOR: 1 1 1  
SAMPLE ID: MBLK1W  
LAB SAMP ID: VO67D21B VO67D21L VO67D21C  
LAB FILE ID: RDC527 RDC524 RDC525  
DATE EXTRACTED: 04/29/1413:15 04/29/1411:44 04/29/1412:15 DATE COLLECTED: NA  
DATE ANALYZED: 04/29/1413:15 04/29/1411:44 04/29/1412:15 DATE RECEIVED: 04/29/14  
PREP. BATCH: VO67D21 VO67D21 VO67D21  
CALIB. REF: RDC168 RDC168 RDC168

## ACCESSION:

| PARAMETER                          | BLNK RSLT<br>(ug/L) | SPIKE AMT<br>(ug/L) | BS RSLT<br>(ug/L) | BS<br>% REC | SPIKE AMT<br>(ug/L) | BSD RSLT<br>(ug/L) | BSD<br>% REC | RPD<br>( % ) | QC LIMIT<br>( % ) | MAX RPD<br>( % ) |
|------------------------------------|---------------------|---------------------|-------------------|-------------|---------------------|--------------------|--------------|--------------|-------------------|------------------|
| Benzene                            | ND                  | 10.0                | 9.32              | 93          | 10.0                | 9.17               | 92           | 2            | 80-120            | 30               |
| Bromodichloromethane               | ND                  | 10.0                | 9.65              | 97          | 10.0                | 9.37               | 94           | 3            | 75-120            | 30               |
| Bromoform                          | ND                  | 10.0                | 10.1              | 101         | 10.0                | 9.80               | 98           | 3            | 70-130            | 30               |
| Bromomethane                       | ND                  | 10.0                | 10.6              | 106         | 10.0                | 9.80               | 98           | 7            | 30-145            | 30               |
| Carbon Tetrachloride               | ND                  | 10.0                | 8.35              | 83          | 10.0                | 8.20               | 82           | 2            | 65-140            | 30               |
| Chlorobenzene                      | ND                  | 10.0                | 9.78              | 98          | 10.0                | 9.68               | 97           | 1            | 80-120            | 30               |
| Chloroethane                       | ND                  | 10.0                | 11.0              | 110         | 10.0                | 10.1               | 101          | 8            | 60-135            | 30               |
| Chloroform                         | ND                  | 10.0                | 9.84              | 98          | 10.0                | 9.56               | 96           | 3            | 65-135            | 30               |
| Chloromethane                      | ND                  | 10.0                | 10.2              | 102         | 10.0                | 9.58               | 96           | 7            | 40-125            | 30               |
| Dibromochloromethane               | ND                  | 10.0                | 9.64              | 96          | 10.0                | 9.49               | 95           | 2            | 60-135            | 30               |
| 1,2-Dichlorobenzene                | ND                  | 10.0                | 10.3              | 103         | 10.0                | 10.1               | 101          | 2            | 70-120            | 30               |
| 1,3-Dichlorobenzene                | ND                  | 10.0                | 10.1              | 101         | 10.0                | 9.91               | 99           | 2            | 75-125            | 30               |
| 1,4-Dichlorobenzene                | ND                  | 10.0                | 10.0              | 100         | 10.0                | 9.87               | 99           | 1            | 75-125            | 30               |
| Dichlorodifluoromethane (Freon 12) | ND                  | 10.0                | 9.93              | 99          | 10.0                | 9.39               | 94           | 6            | 30-155            | 30               |
| 1,1-Dichloroethane                 | ND                  | 10.0                | 9.27              | 93          | 10.0                | 8.99               | 90           | 3            | 70-135            | 30               |
| 1,2-Dichloroethane                 | ND                  | 10.0                | 7.97              | 80          | 10.0                | 7.88               | 79           | 1            | 70-130            | 30               |
| 1,1-Dichloroethene                 | ND                  | 10.0                | 7.58              | 76          | 10.0                | 7.41               | 74           | 2            | 70-130            | 30               |
| 1,2-Dichloroethene (Total)         | ND                  | 20.0                | 17.1              | 85          | 20.0                | 16.6               | 83           | 3            | 70-125            | 30               |
| 1,2-Dichloropropane                | ND                  | 10.0                | 9.90              | 99          | 10.0                | 9.70               | 97           | 2            | 75-125            | 30               |
| Trans-1,3-Dichloropropene          | ND                  | 10.0                | 8.39              | 84          | 10.0                | 8.49               | 85           | 1            | 55-140            | 30               |
| cis-1,3-Dichloropropene            | ND                  | 10.0                | 9.23              | 92          | 10.0                | 8.93               | 89           | 3            | 70-130            | 30               |
| Ethylbenzene                       | ND                  | 10.0                | 9.84              | 98          | 10.0                | 9.67               | 97           | 2            | 75-125            | 30               |
| Methylene Chloride                 | ND                  | 10.0                | 8.28              | 83          | 10.0                | 8.40               | 84           | 1            | 55-140            | 30               |
| 1,1,2,2-Tetrachloroethane          | ND                  | 10.0                | 10.5              | 105         | 10.0                | 10.3               | 103          | 2            | 65-130            | 30               |
| Tetrachloroethene                  | ND                  | 10.0                | 9.31              | 93          | 10.0                | 9.20               | 92           | 1            | 45-150            | 30               |
| Toluene                            | ND                  | 10.0                | 9.57              | 96          | 10.0                | 9.47               | 95           | 1            | 75-120            | 30               |
| 1,1,1-Trichloroethane              | ND                  | 10.0                | 8.74              | 87          | 10.0                | 8.56               | 86           | 2            | 65-130            | 30               |
| 1,1,2-Trichloroethane              | ND                  | 10.0                | 10.3              | 103         | 10.0                | 10.3               | 103          | 0            | 75-125            | 30               |
| Trichlorofluoromethane (Freon 11)  | ND                  | 10.0                | 10.8              | 108         | 10.0                | 9.93               | 99           | 9            | 60-145            | 30               |
| Trichloroethene                    | ND                  | 10.0                | 9.46              | 95          | 10.0                | 9.19               | 92           | 3            | 70-125            | 30               |
| Vinyl Chloride                     | ND                  | 10.0                | 10.3              | 103         | 10.0                | 9.61               | 96           | 7            | 50-145            | 30               |
| Xylenes (Total)                    | ND                  | 30.0                | 28.5              | 95          | 30.0                | 28.0               | 93           | 2            | 80-120            | 30               |

=====

| SURROGATE PARAMETER   | SPIKE AMT<br>(ug/L) | BS RSLT<br>(ug/L) | BS<br>% REC | SPIKE AMT<br>(ug/L) | BSD RSLT<br>(ug/L) | BSD<br>% REC | QC LIMIT<br>( % ) |
|-----------------------|---------------------|-------------------|-------------|---------------------|--------------------|--------------|-------------------|
| 1,2-Dichloroethane-d4 | 10.0                | 8.20              | 82          | 10.0                | 8.24               | 82           | 70-120            |
| 4-Bromofluorobenzene  | 10.0                | 9.69              | 97          | 10.0                | 9.70               | 97           | 75-120            |
| Toluene-d8            | 10.0                | 10.4              | 104         | 10.0                | 10.4               | 104          | 85-120            |
| Dibromofluoromethane  | 10.0                | 9.92              | 99          | 10.0                | 9.85               | 98           | 85-115            |

## Figure 9: TYPICAL MS/MSD SUMMARY

EMAX QUALITY CONTROL DATA  
MS/MSD ANALYSIS

CLIENT: XYZ INC.  
PROJECT: CLEAN WATER PROJECT  
BATCH NO.: YMMNN  
METHOD: SW5030C/8260B

MATRIX: WATER % MOISTURE: NA  
DILUTION FACTOR: 1 1 1  
SAMPLE ID: XXX-59XX001 XXX-59XX001MS XXX-59XX001MSD  
LAB SAMP ID: MNNN-02 MNNN-02M MNNN-02S  
LAB FILE ID: RDC534 RDC535 RDC536  
DATE EXTRACTED: 04/29/1416:55 04/29/1417:26 04/29/1418:15 DATE COLLECTED: NA  
DATE ANALYZED: 04/29/1416:55 04/29/1417:26 04/29/1418:15 DATE RECEIVED: 04/29/14  
PREP. BATCH: VO67D21 VO67D21 VO67D21  
CALIB. REF: RDC168 RDC168 RDC168

ACCESSION:

| PARAMETER                          | BLNK RSLT<br>(ug/L) | SPIKE AMT<br>(ug/L) | BS RSLT<br>(ug/L) | BS<br>% REC | SPIKE AMT<br>(ug/L) | BSD RSLT<br>(ug/L) | BSD<br>% REC | RPD<br>( % ) | QC LIMIT<br>( % ) | MAX RPD<br>( % ) |
|------------------------------------|---------------------|---------------------|-------------------|-------------|---------------------|--------------------|--------------|--------------|-------------------|------------------|
| Benzene                            | ND                  | 10.0                | 9.32              | 93          | 10.0                | 9.17               | 92           | 2            | 80-120            | 30               |
| Bromodichloromethane               | ND                  | 10.0                | 9.65              | 97          | 10.0                | 9.37               | 94           | 3            | 75-120            | 30               |
| Bromoform                          | ND                  | 10.0                | 10.1              | 101         | 10.0                | 9.80               | 98           | 3            | 70-130            | 30               |
| Bromomethane                       | ND                  | 10.0                | 10.6              | 106         | 10.0                | 9.80               | 98           | 7            | 30-145            | 30               |
| Carbon Tetrachloride               | ND                  | 10.0                | 8.35              | 83          | 10.0                | 8.20               | 82           | 2            | 65-140            | 30               |
| Chlorobenzene                      | ND                  | 10.0                | 9.78              | 98          | 10.0                | 9.68               | 97           | 1            | 80-120            | 30               |
| Chloroethane                       | ND                  | 10.0                | 11.0              | 110         | 10.0                | 10.1               | 101          | 8            | 60-135            | 30               |
| Chloroform                         | ND                  | 10.0                | 9.84              | 98          | 10.0                | 9.56               | 96           | 3            | 65-135            | 30               |
| Chloromethane                      | ND                  | 10.0                | 10.2              | 102         | 10.0                | 9.58               | 96           | 7            | 40-125            | 30               |
| Dibromochloromethane               | ND                  | 10.0                | 9.64              | 96          | 10.0                | 9.49               | 95           | 2            | 60-135            | 30               |
| 1,2-Dichlorobenzene                | ND                  | 10.0                | 10.3              | 103         | 10.0                | 10.1               | 101          | 2            | 70-120            | 30               |
| 1,3-Dichlorobenzene                | ND                  | 10.0                | 10.1              | 101         | 10.0                | 9.91               | 99           | 2            | 75-125            | 30               |
| 1,4-Dichlorobenzene                | ND                  | 10.0                | 10.0              | 100         | 10.0                | 9.87               | 99           | 1            | 75-125            | 30               |
| Dichlorodifluoromethane (Freon 12) | ND                  | 10.0                | 9.93              | 99          | 10.0                | 9.39               | 94           | 6            | 30-155            | 30               |
| 1,1-Dichloroethane                 | ND                  | 10.0                | 9.27              | 93          | 10.0                | 8.99               | 90           | 3            | 70-135            | 30               |
| 1,2-Dichloroethane                 | ND                  | 10.0                | 7.97              | 80          | 10.0                | 7.88               | 79           | 1            | 70-130            | 30               |
| 1,1-Dichloroethene                 | ND                  | 10.0                | 7.58              | 76          | 10.0                | 7.41               | 74           | 2            | 70-130            | 30               |
| 1,2-Dichloroethene (Total)         | ND                  | 20.0                | 17.1              | 85          | 20.0                | 16.6               | 83           | 3            | 70-125            | 30               |
| 1,2-Dichloropropane                | ND                  | 10.0                | 9.90              | 99          | 10.0                | 9.70               | 97           | 2            | 75-125            | 30               |
| Trans-1,3-Dichloropropene          | ND                  | 10.0                | 8.39              | 84          | 10.0                | 8.49               | 85           | 1            | 55-140            | 30               |
| cis-1,3-Dichloropropene            | ND                  | 10.0                | 9.23              | 92          | 10.0                | 8.93               | 89           | 3            | 70-130            | 30               |
| Ethylbenzene                       | ND                  | 10.0                | 9.84              | 98          | 10.0                | 9.67               | 97           | 2            | 75-125            | 30               |
| Methylene Chloride                 | ND                  | 10.0                | 8.28              | 83          | 10.0                | 8.40               | 84           | 1            | 55-140            | 30               |
| 1,1,2,2-Tetrachloroethane          | ND                  | 10.0                | 10.5              | 105         | 10.0                | 10.3               | 103          | 2            | 65-130            | 30               |
| Tetrachloroethene                  | ND                  | 10.0                | 9.31              | 93          | 10.0                | 9.20               | 92           | 1            | 45-150            | 30               |
| Toluene                            | ND                  | 10.0                | 9.57              | 96          | 10.0                | 9.47               | 95           | 1            | 75-120            | 30               |
| 1,1,1-Trichloroethane              | ND                  | 10.0                | 8.74              | 87          | 10.0                | 8.56               | 86           | 2            | 65-130            | 30               |
| 1,1,2-Trichloroethane              | ND                  | 10.0                | 10.3              | 103         | 10.0                | 10.3               | 103          | 0            | 75-125            | 30               |
| Trichlorofluoromethane (Freon 11)  | ND                  | 10.0                | 10.8              | 108         | 10.0                | 9.93               | 99           | 9            | 60-145            | 30               |
| Trichloroethene                    | ND                  | 10.0                | 9.46              | 95          | 10.0                | 9.19               | 92           | 3            | 70-125            | 30               |
| Vinyl Chloride                     | ND                  | 10.0                | 10.3              | 103         | 10.0                | 9.61               | 96           | 7            | 50-145            | 30               |
| Xylenes (Total)                    | ND                  | 30.0                | 28.5              | 95          | 30.0                | 28.0               | 93           | 2            | 80-120            | 30               |

| SURROGATE PARAMETER   | SPIKE AMT<br>(ug/L) | BS RSLT<br>(ug/L) | BS<br>% REC | SPIKE AMT<br>(ug/L) | BSD RSLT<br>(ug/L) | BSD<br>% REC | QC LIMIT<br>( % ) |
|-----------------------|---------------------|-------------------|-------------|---------------------|--------------------|--------------|-------------------|
| 1,2-Dichloroethane-d4 | 10.0                | 8.20              | 82          | 10.0                | 8.24               | 82           | 70-120            |
| 4-Bromofluorobenzene  | 10.0                | 9.69              | 97          | 10.0                | 9.70               | 97           | 75-120            |
| Toluene-d8            | 10.0                | 10.4              | 104         | 10.0                | 10.4               | 104          | 85-120            |
| Dibromofluoromethane  | 10.0                | 9.92              | 99          | 10.0                | 9.85               | 98           | 85-115            |

**Figure 10:**

**TYPICAL CASE NARRATIVE**

---

CASE NARRATIVE

Client : XYZ INC.

Project : CLEAN WATER PROJECT

SDG : YYDNNN

METHOD SW5030C/8260B  
VOLATILE ORGANICS BY GC/MS

A total of two (2) water samples were received on 04/29/14 for Volatile Organics by GC/MS analysis, Method 5030C/8260B in accordance with USEPA SW-846, Test Methods for Evaluating Solid Waste, Physical/Chemical Methods and Project QAPP Clean Water Project.

Holding Time

Samples were analyzed within the prescribed holding time.

Instrument Performance and Calibration

Instrument tune check was performed prior to calibration. Instrument mass ratios were within specification. Multi-calibration points were generated to establish initial calibration (ICAL). ICAL was verified using secondary source (ICV). Continuing calibration (CCV) was carried on at a frequency required by the project. All project calibration requirements were satisfied. Refer to calibration summary forms of ICAL, ICV and CCV for details.

Method Blank

Method blank was analyzed at the frequency required by the project. For this SDG, one method blank was analyzed with the samples. Results were compliant to project requirement.

Lab Control Sample

A set of LCS/LCD was analyzed with the samples in this SDG.  
Percent recoveries for VO67D21L/C were all within QC limits.

Matrix QC Sample

Matrix QC sample was analyzed at the frequency prescribed by the project.  
Percent recoveries and RPDs for MNNN-02M/S were within project QC limits.

Surrogate

Surrogates were added on QC and field samples. Surrogate recoveries were within project QC limits. Refer to sample result forms for details.

Sample Analysis

Samples were analyzed according to prescribed analytical procedures. All project requirements were met; otherwise, anomalies were discussed within the associated QC parameter.



**Appendix 1:**

**SUMMARY OF QUALITY CONTROL PROCEDURES**

| QC PROCEDURE   | FREQUENCY   | ACCEPTANCE CRITERIA  | CORRECTIVE ACTION   | 1st Rvw      | 2 <sup>nd</sup> Rvw |
|--|---|--|---|--------------|---------------------|
| Check of mass spectral ion intensities using BFB   | Prior to initial calibration and calibration verification         | Refer to criteria listed in Table 5  | Retune instrument and verify  |              |                     |
| Multi point Initial Calibration(ICAL) minimum of 5 points  | Initially; as needed  | SPCCs :<br>RF $\geq$ 0.1 for Bromoform, Chloromethane and 1,1-Dichloroethane<br>RF $\geq$ 0.3 for Chlorobenzene and 1,1,2,2-Tetrachloroethane<br>CCC: RSD $\leq$ 30% for the following analytes:<br>Chloroform, 1,1-DCE, 1,2-DCP, Ethylbenzene, Toluene and Vinyl Chloride.<br>1.) if RRF is applied, then RSD $\leq$ 15%<br>2.) If 1st order is applied, then $r \geq$ 0.995 with min 5 pt ICAL<br>3.) If 2nd order is applied, then $r \geq$ 0.99 with min 6 pt ICAL | Check for outliers. Otherwise, optimize the instrument then repeat initial calibration.   |              |                     |
| Initial calibration verification (ICV)   | After initial calibration   | All analytes within $\pm$ 20% of expected value except for the following compounds due to erratic chromatographic behavior: Bromomethane, Chloroethane, Chloromethane, Dichlorodifluoromethane but must be within $\pm$ 35% of expected value.   | Verify second source standard. Prepare fresh standard and rerun ICV. If that fails, Optimize instrument and repeat ICAL.  |              |                     |
| Evaluation of relative retention times (RRT)   | Each sample   | Within $\pm$ 0.06 RRT units  | Correct the problem then reanalyze all samples analyzed since the last retention time check   |              |                     |
| Continuing Calibration verification (CCV)  | Daily, before sample analysis and every 12 hours of analysis time | SPCCs: Min. RF same as ICAL<br>CCC : %Diff $\leq$ 20% (when using RFs) or drift (when using least squares regression or non-linear calibration)  | Correct the problem then repeat initial calibration   |              |                     |
| Internal Standard (IS)   | All samples   | Retention time $\pm$ 30 seconds from retention time of the midpoint standard in the ICAL;<br>EICP area within -50% to +100% of ICAL midpoint standard  | Inspect mass spectrometer and GC for malfunctions; mandatory reanalysis of samples analyzed while system was malfunctioning   |              |                     |
| Method blank (MB)  | One per preparation batch   | No analytes detected $>$ $\frac{1}{2}$ LOQ   | Rule out instrument contamination by re-analyzing the MB. If problem persist refer to PSR. In the absence of PSR, report NDs and results $>$ 10X of the MB concentration. Otherwise, cure contamination source, re-prep and re-analyze method blank and all associated samples. |              |                     |
| LCS  | One LCS per preparation   | Within project QC Limits   | Re-prep and re-analyze the LCS and all associated samples   |              |                     |
| MS/MSD   | One MS/MSD per every 20 project samples per matrix                | Within project QC Limits   | Check if sample was properly spiked. If indicative of matrix interference, discuss in case narrative, otherwise re-prep and re-analyze the sample   |              |                     |
| Surrogate  | Every Sample, MB, LCS, MS/MSD, DCC                                | Within project QC Limits   | Correct the problem then re-analyze   |              |                     |
| <b>Comments:</b><br>This QCP is applicable in the absence of the PSR<br>Report values between LOD and LOQ. Refer to PSR for Flagging Criteria. |   |  |   | Reviewed by: |                     |
|  |   |  |   | Date:        |                     |

**Appendix 2: DEMONSTRATION OF CAPABILITY for 25 ml**

DEMONSTRATION OF CAPABILITY  
METHOD: SW 8260

Unit: ug/L  
Sample Amount(ml): 25  
Sample Purge(ml): 25

Date Analyzed: 01/31 & 02/01/12  
Analyzed by: D. Nguyen

| PARAMETER                   | RAY133   | RAY134   | RBY004   | RBY005   | True Value | Ave. Conc. | Ave. % Rec. | Std. Dev. | RSD | QC Criteria | Comments |
|-----------------------------|----------|----------|----------|----------|------------|------------|-------------|-----------|-----|-------------|----------|
|                             | VOF5A10L | VOF5A10C | VOF5B01L | VOF5B01C |            |            |             |           |     |             |          |
| Acetone                     | 46.2     | 49.8     | 45.0     | 49.4     | 50         | 47.6       | 95          | 2.378     | 5   | 60 - 130    | Passed   |
| Acetonitrile                | 83.4     | 86.1     | 88.7     | 83.0     | 100        | 85.3       | 85          | 2.632     | 3   | 50 - 130    | Passed   |
| Acrolein                    | 47.0     | 50.2     | 42.0     | 48.0     | 50         | 46.8       | 94          | 3.502     | 7   | 10 - 160    | Passed   |
| Acrylonitrile               | 50.0     | 52.1     | 45.0     | 51.3     | 50         | 49.6       | 99          | 3.188     | 6   | 60 - 150    | Passed   |
| Benzene                     | 9.39     | 10.0     | 9.71     | 9.62     | 10         | 9.69       | 97          | 0.255     | 3   | 70 - 130    | Passed   |
| Bromobenzene                | 9.65     | 10.4     | 9.85     | 10.1     | 10         | 10.0       | 100         | 0.344     | 3   | 70 - 130    | Passed   |
| Bromochloromethane          | 9.08     | 9.78     | 9.18     | 9.48     | 10         | 9.4        | 94          | 0.315     | 3   | 70 - 130    | Passed   |
| Bromodichloromethane        | 9.58     | 10.1     | 9.81     | 10.0     | 10         | 9.9        | 99          | 0.239     | 2   | 70 - 130    | Passed   |
| Bromoform                   | 9.70     | 10.3     | 9.00     | 10.0     | 10         | 9.76       | 98          | 0.568     | 6   | 60 - 130    | Passed   |
| Bromomethane                | 9.49     | 10.2     | 10.6     | 10.3     | 10         | 10.14      | 101         | 0.465     | 5   | 50 - 140    | Passed   |
| tert-Butyl alcohol          | 51.8     | 54.4     | 42.6     | 48.4     | 50         | 49.3       | 99          | 5.096     | 10  | 50 - 150    | Passed   |
| 2-Butanone (MEK)            | 49.3     | 51.8     | 42.1     | 50.5     | 50         | 48.4       | 97          | 4.344     | 9   | 70 - 130    | Passed   |
| n-Butylbenzene              | 10.0     | 10.8     | 11.1     | 10.4     | 10         | 10.6       | 106         | 0.472     | 4   | 70 - 130    | Passed   |
| sec-Butylbenzene            | 9.94     | 10.8     | 10.8     | 10.5     | 10         | 10.5       | 105         | 0.397     | 4   | 70 - 130    | Passed   |
| tert-Butylbenzene           | 8.78     | 9.46     | 9.31     | 8.95     | 10         | 9.1        | 91          | 0.315     | 3   | 70 - 130    | Passed   |
| Carbon disulfide            | 9.24     | 10.2     | 8.45     | 8.74     | 10         | 9.15       | 92          | 0.755     | 8   | 50 - 130    | Passed   |
| Carbon tetrachloride        | 9.24     | 10.0     | 10.0     | 9.65     | 10         | 9.7        | 97          | 0.343     | 4   | 60 - 130    | Passed   |
| Chlorobenzene               | 9.08     | 9.68     | 9.39     | 9.22     | 10         | 9.3        | 93          | 0.257     | 3   | 70 - 130    | Passed   |
| 2-Chloroethyl vinyl ether   | 9.55     | 9.91     | 8.16     | 9.38     | 10         | 9.3        | 93          | 0.760     | 8   | 10 - 160    | Passed   |
| Chloroethane                | 9.11     | 9.81     | 9.89     | 10.1     | 10         | 9.72       | 97          | 0.414     | 4   | 60 - 130    | Passed   |
| Chloroform                  | 9.02     | 9.65     | 9.54     | 9.39     | 10         | 9.4        | 94          | 0.272     | 3   | 70 - 130    | Passed   |
| 1-Chlorohexane              | 8.77     | 9.38     | 9.10     | 8.85     | 10         | 9.0        | 90          | 0.278     | 3   | 70 - 130    | Passed   |
| Chloromethane               | 9.12     | 9.52     | 9.39     | 9.53     | 10         | 9.39       | 94          | 0.191     | 2   | 50 - 130    | Passed   |
| 2-Chlorotoluene             | 9.86     | 10.7     | 10.1     | 10.7     | 10         | 10.3       | 103         | 0.433     | 4   | 70 - 130    | Passed   |
| 4-Chlorotoluene             | 9.70     | 10.4     | 11.1     | 9.9      | 10         | 10.3       | 103         | 0.611     | 6   | 70 - 130    | Passed   |
| Isopropyl ether (DIPE)      | 9.76     | 10.4     | 9.33     | 9.68     | 10         | 9.8        | 98          | 0.435     | 4   | 70 - 130    | Passed   |
| Dibromochloromethane        | 9.85     | 10.4     | 9.62     | 10.2     | 10         | 10.0       | 100         | 0.346     | 3   | 70 - 130    | Passed   |
| 1,2-Dibromo-3-chloropropane | 9.14     | 9.80     | 8.25     | 8.90     | 10         | 9.02       | 90          | 0.641     | 7   | 60 - 130    | Passed   |
| 1,2-Dibromoethane           | 9.90     | 10.5     | 9.39     | 10.2     | 10         | 10.0       | 100         | 0.487     | 5   | 70 - 130    | Passed   |
| Dibromomethane              | 9.82     | 10.3     | 8.87     | 9.58     | 10         | 9.6        | 96          | 0.584     | 6   | 70 - 130    | Passed   |
| 1,1-Dichloroethane          | 9.15     | 9.83     | 9.42     | 9.31     | 10         | 9.4        | 94          | 0.292     | 3   | 70 - 130    | Passed   |
| 1,2-Dichloroethane          | 9.45     | 10.0     | 9.52     | 9.89     | 10         | 9.7        | 97          | 0.261     | 3   | 70 - 130    | Passed   |
| 1,2-Dichlorobenzene         | 8.98     | 9.68     | 9.33     | 9.26     | 10         | 9.3        | 93          | 0.290     | 3   | 70 - 130    | Passed   |
| 1,3-Dichlorobenzene         | 9.61     | 10.4     | 9.92     | 9.88     | 10         | 9.9        | 99          | 0.327     | 3   | 70 - 130    | Passed   |
| trans-1,4-Dichloro-2-Butene | 10.6     | 11.5     | 9.58     | 10.8     | 10         | 10.6       | 106         | 0.812     | 8   | 50 - 140    | Passed   |
| 1,4-Dichlorobenzene         | 9.82     | 10.6     | 10.1     | 10.1     | 10         | 10.2       | 102         | 0.340     | 3   | 70 - 130    | Passed   |
| Dichlorodifluoromethane     | 9.14     | 10.0     | 9.22     | 9.67     | 10         | 9.50       | 95          | 0.383     | 4   | 50 - 140    | Passed   |
| 1,1-Dichloroethene          | 9.17     | 9.8      | 9.40     | 9.27     | 10         | 9.4        | 94          | 0.289     | 3   | 60 - 130    | Passed   |
| cis-1,2-Dichloroethene      | 9.40     | 10.1     | 9.71     | 9.60     | 10         | 9.7        | 97          | 0.285     | 3   | 70 - 130    | Passed   |
| trans-1,2-Dichloroethene    | 9.27     | 9.83     | 9.34     | 9.21     | 10         | 9.4        | 94          | 0.282     | 3   | 60 - 130    | Passed   |
| Dichlorofluoromethane       | 8.27     | 9.12     | 9.84     | 9.25     | 10         | 9.12       | 91          | 0.646     | 7   | 70 - 130    | Passed   |
| 1,1-Dichloropropene         | 9.42     | 10.2     | 9.79     | 9.72     | 10         | 9.8        | 98          | 0.319     | 3   | 70 - 130    | Passed   |
| 1,2-Dichloropropene         | 9.43     | 10.0     | 9.48     | 9.68     | 10         | 9.6        | 96          | 0.256     | 3   | 70 - 130    | Passed   |
| 1,3-Dichloropropane         | 9.82     | 10.4     | 9.54     | 10.1     | 10         | 10.0       | 100         | 0.359     | 4   | 70 - 130    | Passed   |

**Appendix 2 (cont.): DEMONSTRATION OF CAPABILITY for 25 ml**

DEMONSTRATION OF CAPABILITY  
METHOD: SW 8260

Unit: ug/L  
Sample Amount(ml): 25  
Sample Purge(ml): 25

Date Analyzed: 01/31 & 02/01/12  
Analyzed by: D. Nguyen

| PARAMETER                             | RAY133   | RAY134   | RBV004   | RBV005   | True Value | Ave. Conc. | Ave. % Rec. | Std. Dev. | RSD | QC Criteria | Comments |
|---------------------------------------|----------|----------|----------|----------|------------|------------|-------------|-----------|-----|-------------|----------|
|                                       | VOF5A10L | VOF5A10C | VOF5B01L | VOF5B01C |            |            |             |           |     |             |          |
| 2,2-Dichloropropane                   | 9.07     | 10.4     | 10.2     | 9.65     | 10         | 9.8        | 98          | 0.598     | 6   | 60 - 140    | Passed   |
| cis-1,3-Dichloropropene               | 10.0     | 10.7     | 10.0     | 10.3     | 10         | 10.3       | 103         | 0.339     | 3   | 70 - 130    | Passed   |
| trans-1,3-Dichloropropene             | 9.30     | 9.75     | 9.06     | 9.42     | 10         | 9.4        | 94          | 0.288     | 3   | 70 - 130    | Passed   |
| tert-Butyl ethyl ether (ETB)          | 11.1     | 11.8     | 10.1     | 10.8     | 10         | 11.0       | 110         | 0.685     | 6   | 70 - 130    | Passed   |
| Ethyl Methacrylate                    | 9.30     | 9.68     | 8.15     | 9.21     | 10         | 9.1        | 91          | 0.656     | 7   | 70 - 130    | Passed   |
| Ethylbenzene                          | 9.47     | 10.1     | 10.0     | 9.68     | 10         | 9.8        | 98          | 0.300     | 3   | 70 - 130    | Passed   |
| 2-Hexanone (MBK)                      | 50.6     | 52.3     | 42.7     | 50.6     | 50         | 49.0       | 98          | 4.298     | 9   | 70 - 140    | Passed   |
| Hexachlorobutadiene                   | 8.21     | 8.92     | 8.99     | 8.08     | 10         | 8.6        | 86          | 0.469     | 5   | 70 - 130    | Passed   |
| Iodomethane                           | 9.16     | 10.0     | 9.31     | 9.21     | 10         | 9.43       | 94          | 0.417     | 4   | 50 - 150    | Passed   |
| Isopropylbenzene                      | 10.4     | 11.2     | 11.0     | 10.8     | 10         | 10.9       | 109         | 0.380     | 3   | 70 - 130    | Passed   |
| p-Isopropyltoluene                    | 10.1     | 11.0     | 11.0     | 10.4     | 10         | 10.6       | 106         | 0.423     | 4   | 70 - 130    | Passed   |
| Methylene Chloride                    | 8.56     | 9.09     | 8.74     | 8.87     | 10         | 8.8        | 88          | 0.225     | 3   | 60 - 130    | Passed   |
| 4-Methyl-2-pentanone (MIBK)           | 52.9     | 54.7     | 45.5     | 53.6     | 50         | 51.7       | 103         | 4.184     | 8   | 70 - 130    | Passed   |
| tert-Butyl methyl ether               | 10.1     | 10.7     | 8.99     | 10.1     | 10         | 10.0       | 100         | 0.723     | 7   | 60 - 130    | Passed   |
| Naphthalene                           | 10.3     | 10.7     | 9.41     | 9.88     | 10         | 10.07      | 101         | 0.565     | 6   | 50 - 140    | Passed   |
| n-Propylbenzene                       | 10.6     | 11.4     | 11.2     | 11.1     | 10         | 11.1       | 111         | 0.369     | 3   | 70 - 130    | Passed   |
| Styrene                               | 9.63     | 10.4     | 10.0     | 9.8      | 10         | 10.0       | 100         | 0.311     | 3   | 70 - 130    | Passed   |
| tert-Amyl methyl ether (TAME)         | 11.3     | 12.0     | 10.2     | 11.1     | 10         | 11.1       | 111         | 0.747     | 7   | 60 - 140    | Passed   |
| 1,1,1,2-Tetrachloroethane             | 9.32     | 9.91     | 9.59     | 9.54     | 10         | 9.6        | 96          | 0.246     | 3   | 70 - 130    | Passed   |
| 1,1,1,2-Tetrachloroethane             | 9.92     | 10.6     | 9.52     | 10.5     | 10         | 10.1       | 101         | 0.501     | 5   | 60 - 130    | Passed   |
| Tetrachloroethene                     | 9.08     | 9.77     | 9.50     | 9.01     | 10         | 9.3        | 93          | 0.356     | 4   | 60 - 130    | Passed   |
| Toluene                               | 9.68     | 10.3     | 10.1     | 9.94     | 10         | 10.0       | 100         | 0.262     | 3   | 70 - 130    | Passed   |
| 1,1,1-Trichloroethane                 | 8.83     | 10.0     | 10.2     | 9.52     | 10         | 9.6        | 96          | 0.591     | 6   | 70 - 130    | Passed   |
| 1,1,2-Trichloroethane                 | 9.67     | 10.1     | 9.45     | 10.1     | 10         | 9.8        | 98          | 0.346     | 4   | 70 - 130    | Passed   |
| 1,2,3-Trichlorobenzene                | 8.77     | 9.14     | 8.46     | 8.40     | 10         | 8.7        | 87          | 0.339     | 4   | 60 - 130    | Passed   |
| 1,2,4-Trichlorobenzene                | 9.04     | 9.63     | 8.93     | 8.60     | 10         | 9.1        | 91          | 0.432     | 5   | 60 - 140    | Passed   |
| Trichloroethene                       | 9.21     | 9.93     | 9.42     | 9.29     | 10         | 9.5        | 95          | 0.326     | 3   | 70 - 130    | Passed   |
| Trichlorofluoromethane                | 9.06     | 9.62     | 10.1     | 10.3     | 10         | 9.76       | 98          | 0.544     | 6   | 60 - 140    | Passed   |
| 1,2,3-Trichloropropane                | 9.93     | 10.5     | 9.45     | 10.6     | 10         | 10.1       | 101         | 0.524     | 5   | 70 - 130    | Passed   |
| 1,1,2-Trichloro-1,2,2-trifluoroethane | 8.70     | 9.49     | 9.45     | 9.05     | 10         | 9.2        | 92          | 0.376     | 4   | 60 - 150    | Passed   |
| 1,2,4-Trimethylbenzene                | 9.8      | 10.6     | 10.6     | 10.2     | 10         | 10.3       | 103         | 0.374     | 4   | 70 - 130    | Passed   |
| 1,3,5-Trimethylbenzene                | 9.9      | 10.7     | 10.5     | 10.2     | 10         | 10.3       | 103         | 0.335     | 3   | 70 - 130    | Passed   |
| Vinyl Acetate                         | 10.9     | 11.0     | 9.68     | 11.1     | 10         | 10.66      | 107         | 0.662     | 6   | 40 - 150    | Passed   |
| Vinyl Chloride                        | 8.26     | 8.56     | 9.02     | 9.01     | 10         | 8.71       | 87          | 0.372     | 4   | 60 - 130    | Passed   |
| m-Xylene & p-xylene                   | 19.2     | 20.6     | 20.4     | 19.6     | 20         | 19.9       | 100         | 0.633     | 3   | 60 - 140    | Passed   |
| o-Xylene                              | 8.80     | 9.41     | 9.18     | 8.93     | 10         | 9.1        | 91          | 0.270     | 3   | 70 - 130    | Passed   |
| 1,2-Dichloroethane-d4                 | 10.0     | 10.0     | 9.9      | 10.3     | 10         | 10.05      | 101         | 0.200     | 2   | 70 - 130    | Passed   |
| Toluene-d8                            | 10.3     | 10.3     | 10.4     | 10.3     | 10         | 10.32      | 103         | 0.046     | 0.5 | 70 - 130    | Passed   |
| 4-Bromofluorobenzene                  | 10.6     | 10.6     | 10.5     | 10.9     | 10         | 10.68      | 107         | 0.189     | 2   | 70 - 130    | Passed   |
| Dibromofluoromethane                  | 10.0     | 9.93     | 10.1     | 10.2     | 10         | 10.06      | 101         | 0.106     | 1   | 70 - 130    | Passed   |

### Appendix 3: DEMONSTRATION OF CAPABILITY for 5 ml

DEMONSTRATION OF CAPABILITY  
METHOD: SW 8260

| PARAMETER                      | RAN044   | RAN045   | RAN058   | RAN059   | True Value | Ave. Conc. | Ave. % Rec. | Std. Dev. | RSD | QC Criteria | Comments |
|--------------------------------|----------|----------|----------|----------|------------|------------|-------------|-----------|-----|-------------|----------|
|                                | VSF4A07L | VSF4A07C | VSF4A08L | VSF4A08C |            |            |             |           |     |             |          |
| Acetone                        | 261      | 261      | 275      | 272      | 250        | 267        | 107         | 7.569     | 3   | 60 130      | Passed   |
| Acetonitrile                   | 540      | 546      | 510      | 533      | 500        | 532        | 106         | 15.685    | 3   | 30 160      | Passed   |
| Acrolein                       | 334      | 330      | 337      | 325      | 250        | 331        | 133         | 5.396     | 2   | 30 160      | Passed   |
| Acrylonitrile                  | 269      | 270      | 278      | 271      | 250        | 272        | 109         | 4.119     | 2   | 70 130      | Passed   |
| Benzene                        | 51.0     | 52.3     | 48.2     | 49.6     | 50         | 50.3       | 101         | 1.744     | 3   | 70 130      | Passed   |
| Bromobenzene                   | 46.8     | 48.0     | 45.4     | 46.2     | 50         | 46.6       | 93          | 1.104     | 2   | 70 130      | Passed   |
| Bromochloromethane             | 51.7     | 52.2     | 50.7     | 51.2     | 50         | 51.5       | 103         | 0.611     | 1   | 70 130      | Passed   |
| Bromodichloromethane           | 49.5     | 50.8     | 48.4     | 49.2     | 50         | 49.5       | 99          | 1.022     | 2   | 70 130      | Passed   |
| Bromoform                      | 47.8     | 48.6     | 45.6     | 47.5     | 50         | 47.4       | 95          | 1.282     | 3   | 70 130      | Passed   |
| Bromomethane                   | 54.8     | 51.5     | 50.4     | 50.5     | 50         | 51.8       | 104         | 2.076     | 4   | 60 130      | Passed   |
| tert-Butyl alcohol             | 281      | 286      | 255      | 271      | 250        | 273        | 109         | 13.969    | 5   | 60 140      | Passed   |
| 2-Butanone (MEK)               | 279      | 278      | 284      | 282      | 250        | 281        | 112         | 3.049     | 1   | 70 130      | Passed   |
| n-Butylbenzene                 | 53.8     | 54.5     | 49.7     | 50.6     | 50         | 52.2       | 104         | 2.387     | 5   | 70 130      | Passed   |
| sec-Butylbenzene               | 52.0     | 52.5     | 47.9     | 49.4     | 50         | 50.5       | 101         | 2.181     | 4   | 70 130      | Passed   |
| tert-Butylbenzene              | 52.4     | 52.3     | 48.2     | 49.6     | 50         | 50.6       | 101         | 2.047     | 4   | 70 130      | Passed   |
| Carbon disulfide               | 48.2     | 46.9     | 44.2     | 46.0     | 50         | 46.4       | 93          | 1.669     | 4   | 60 130      | Passed   |
| Carbon tetrachloride           | 52.9     | 53.1     | 49.7     | 51.2     | 50         | 51.7       | 103         | 1.588     | 3   | 70 130      | Passed   |
| Chlorobenzene                  | 49.3     | 50.2     | 47.1     | 47.9     | 50         | 48.6       | 97          | 1.402     | 3   | 70 130      | Passed   |
| 2-Chloroethyl vinyl ether      | 50.1     | 49.7     | 36.4     | 38.4     | 50         | 43.7       | 87          | 7.258     | 17  | 50 150      | Passed   |
| Chloroethane                   | 58.5     | 52.1     | 53.0     | 53.1     | 50         | 54.2       | 108         | 2.944     | 5   | 70 130      | Passed   |
| Chloroform                     | 52.1     | 52.6     | 50.9     | 51.3     | 50         | 51.7       | 103         | 0.749     | 1   | 70 130      | Passed   |
| 1-Chlorohexane                 | 56.0     | 56.6     | 50.6     | 51.8     | 50         | 53.7       | 107         | 2.974     | 6   | 70 130      | Passed   |
| Chloromethane                  | 53.8     | 48.8     | 48.5     | 50.0     | 50         | 50.3       | 101         | 2.456     | 5   | 60 130      | Passed   |
| 2-Chlorotoluene                | 49.0     | 48.9     | 45.9     | 46.6     | 50         | 47.6       | 95          | 1.619     | 3   | 70 130      | Passed   |
| 4-Chlorotoluene                | 51.9     | 53.0     | 49.5     | 49.8     | 50         | 51.1       | 102         | 1.675     | 3   | 70 130      | Passed   |
| 2-Chloro-1,1,1-trifluoroethane | 54.6     | 53.8     | 51.2     | 54.3     | 50         | 53.5       | 107         | 1.562     | 3   | 30 160      | Passed   |
| Chlorotrifluoroethylene        | 46.4     | 44.7     | 41.6     | 45.6     | 50         | 44.6       | 89          | 2.093     | 5   | 30 160      | Passed   |
| Dibromochloromethane           | 48.4     | 49.7     | 47.4     | 47.9     | 50         | 48.4       | 97          | 1.017     | 2   | 70 130      | Passed   |
| 1,2-Dibromo-3-chloropropane    | 47.1     | 47.9     | 44.3     | 45.6     | 50         | 46.2       | 92          | 1.577     | 3   | 60 130      | Passed   |
| 1,2-Dibromoethane              | 49.2     | 50.7     | 47.3     | 48.4     | 50         | 48.9       | 98          | 1.452     | 3   | 70 130      | Passed   |
| Dibromomethane                 | 48.1     | 49.6     | 47.1     | 48.3     | 50         | 48.3       | 97          | 1.022     | 2   | 70 130      | Passed   |
| 1,1-Dichloroethane             | 55.3     | 55.9     | 52.7     | 53.4     | 50         | 54.3       | 109         | 1.554     | 3   | 70 130      | Passed   |
| 1,2-Dichloroethane             | 49.5     | 50.1     | 48.7     | 49.8     | 50         | 49.5       | 99          | 0.593     | 1   | 70 130      | Passed   |
| 1,2-Dichlorobenzene            | 47.0     | 47.6     | 45.5     | 45.6     | 50         | 46.4       | 93          | 1.084     | 2   | 70 130      | Passed   |
| 1,3-Dichlorobenzene            | 48.6     | 49.3     | 45.9     | 46.2     | 50         | 47.5       | 95          | 1.704     | 4   | 70 130      | Passed   |
| trans-1,4-Dichloro-2-Butene    | 51.0     | 50.7     | 48.7     | 50.0     | 50         | 50.1       | 100         | 1.012     | 2   | 70 130      | Passed   |
| 1,4-Dichlorobenzene            | 49.0     | 49.7     | 46.6     | 46.7     | 50         | 48.0       | 96          | 1.599     | 3   | 70 130      | Passed   |
| Dichlorodifluoromethane        | 51.3     | 47.0     | 46.7     | 47.4     | 50         | 48.1       | 96          | 2.151     | 4   | 60 130      | Passed   |
| 1,1-Dichloroethene             | 58.3     | 58.5     | 54.2     | 55.1     | 50         | 56.5       | 113         | 2.189     | 4   | 70 130      | Passed   |
| cis-1,2-Dichloroethene         | 53.3     | 53.5     | 50.9     | 51.2     | 50         | 52.2       | 104         | 1.358     | 3   | 70 130      | Passed   |
| trans-1,2-Dichloroethene       | 55.7     | 55.7     | 51.9     | 52.8     | 50         | 54.0       | 108         | 1.960     | 4   | 70 130      | Passed   |
| Dichlorofluoromethane          | 56.9     | 57.0     | 54.7     | 55.1     | 50         | 55.9       | 112         | 1.234     | 2   | 70 130      | Passed   |
| 1,1-Dichloropropene            | 53.1     | 53.5     | 48.5     | 49.7     | 50         | 51.2       | 102         | 2.483     | 5   | 70 130      | Passed   |
| 1,2-Dichloropropane            | 51.0     | 52.2     | 48.8     | 50.4     | 50         | 50.6       | 101         | 1.413     | 3   | 70 130      | Passed   |

Unit: ug/L  
Sample Amount(ml): 5  
Sample Purge(ml): 5

Date Analyzed: 01/07/13 & 01/08/13  
Analyzed by: C. Mendoza

**Appendix 3 (cont.): DEMONSTRATION OF CAPABILITY for 5 ml**

DEMONSTRATION OF CAPABILITY  
METHOD: SW 8260

| PARAMETER                             | RAN044   | RAN045   | RAN058   | RAN059   | True Value | Ave. Conc. | Ave. % Rec. | Std. Dev. | RSD | QC Criteria | Comments |
|---------------------------------------|----------|----------|----------|----------|------------|------------|-------------|-----------|-----|-------------|----------|
|                                       | V5F4A07L | V5F4A07C | V5F4A08L | V5F4A08C |            |            |             |           |     |             |          |
| 1,3-Dichloropropane                   | 49.4     | 50.8     | 47.8     | 49.3     | 50         | 49.3       | 99          | 1.251     | 3   | 70 130      | Passed   |
| 2,2-Dichloropropane                   | 57.2     | 57.1     | 54.0     | 54.5     | 50         | 55.7       | 111         | 1.706     | 3   | 70 140      | Passed   |
| cis-1,3-Dichloropropene               | 51.3     | 52.8     | 49.1     | 50.4     | 50         | 50.9       | 102         | 1.548     | 3   | 70 130      | Passed   |
| trans-1,3-Dichloropropene             | 51.2     | 52.4     | 49.6     | 50.5     | 50         | 50.9       | 102         | 1.191     | 2   | 70 130      | Passed   |
| tert-Butyl ethyl ether (ETB)          | 56.5     | 57.2     | 53.8     | 55.1     | 50         | 55.7       | 111         | 1.523     | 3   | 70 130      | Passed   |
| Ethyl Methacrylate                    | 52.9     | 53.6     | 49.9     | 51.0     | 50         | 52         | 104         | 1.679     | 3   | 30 160      | Passed   |
| Ethylbenzene                          | 51.6     | 52.9     | 48.5     | 49.6     | 50         | 50.7       | 101         | 1.946     | 4   | 70 130      | Passed   |
| 2-Hexanone (MBK)                      | 275      | 275      | 284      | 277      | 250        | 278.0      | 111         | 4.403     | 2   | 70 130      | Passed   |
| Hexachlorobutadiene                   | 47.3     | 49.2     | 45.7     | 45.1     | 50         | 46.8       | 94          | 1.814     | 4   | 70 130      | Passed   |
| Iodomethane                           | 40.7     | 39.4     | 36.9     | 39.0     | 50         | 39.0       | 78          | 1.595     | 4   | 60 130      | Passed   |
| Isopropyl ether (DIPE)                | 57.2     | 58.2     | 54.5     | 56.0     | 50         | 56.5       | 113         | 1.595     | 3   | 70 130      | Passed   |
| Isopropylbenzene                      | 52.1     | 52.3     | 48.0     | 49.5     | 50         | 50.5       | 101         | 2.093     | 4   | 70 130      | Passed   |
| p-Isopropyltoluene                    | 52.4     | 53.0     | 48.7     | 49.2     | 50         | 51         | 102         | 2.199     | 4   | 70 130      | Passed   |
| Methyl acetate                        | 52.9     | 52.1     | 54.2     | 55.6     | 50         | 53.7       | 107         | 1.525     | 3   | 30 160      | Passed   |
| Methylene Chloride                    | 50.4     | 51.6     | 49.6     | 50.2     | 50         | 50.5       | 101         | 0.856     | 2   | 70 130      | Passed   |
| 4-Methyl-2-pentanone (MIBK)           | 278      | 279      | 283      | 276      | 250        | 278.7      | 111         | 2.713     | 1   | 70 130      | Passed   |
| tert-Butyl methyl ether               | 54.7     | 55.3     | 52.6     | 53.8     | 50         | 54.1       | 108         | 1.140     | 2   | 70 130      | Passed   |
| Naphthalene                           | 43.7     | 44.3     | 40.8     | 39.8     | 50         | 42.2       | 84          | 2.180     | 5   | 60 140      | Passed   |
| n-Propylbenzene                       | 51.9     | 52.3     | 47.9     | 49.3     | 50         | 50.4       | 101         | 2.098     | 4   | 70 130      | Passed   |
| Styrene                               | 51.6     | 53.2     | 49.6     | 50.4     | 50         | 51.2       | 102         | 1.553     | 3   | 70 130      | Passed   |
| tert-Amyl methyl ether (TAME)         | 55.3     | 56.0     | 53.3     | 54.2     | 50         | 54.7       | 109         | 1.212     | 2   | 70 130      | Passed   |
| 1,1,1,2-Tetrachloroethane             | 48.7     | 50.4     | 47.5     | 48.2     | 50         | 48.7       | 97          | 1.250     | 3   | 30 160      | Passed   |
| 1,1,2,2-Tetrachloroethane             | 49.1     | 49.2     | 45.7     | 47.4     | 50         | 47.9       | 96          | 1.652     | 3   | 30 160      | Passed   |
| Tetrachloroethene                     | 50.6     | 51.2     | 47.0     | 48.0     | 50         | 49.2       | 98          | 2.014     | 4   | 70 130      | Passed   |
| Toluene                               | 51.3     | 52.4     | 48.6     | 49.7     | 50         | 50.5       | 101         | 1.718     | 3   | 70 130      | Passed   |
| 1,1,1-Trichloroethane                 | 55.0     | 55.2     | 52.6     | 52.9     | 50         | 53.9       | 108         | 1.405     | 3   | 30 160      | Passed   |
| 1,1,2-Trichloroethane                 | 48.3     | 50.1     | 46.3     | 48.0     | 50         | 48.2       | 96          | 1.553     | 3   | 30 160      | Passed   |
| 1,2,3-Trichlorobenzene                | 48.0     | 49.6     | 46.0     | 44.8     | 50         | 47.1       | 94          | 2.140     | 5   | 70 130      | Passed   |
| 1,2,4-Trichlorobenzene                | 50.8     | 51.5     | 46.7     | 45.5     | 50         | 48.6       | 97          | 2.965     | 6   | 70 130      | Passed   |
| Trichloroethene                       | 50.7     | 51.5     | 47.7     | 48.3     | 50         | 49.5       | 99          | 1.834     | 4   | 70 130      | Passed   |
| Trichlorofluoromethane                | 61.7     | 55.1     | 54.8     | 55.3     | 50         | 56.7       | 113         | 3.322     | 6   | 70 140      | Passed   |
| 1,2,3-Trichloropropane                | 47.8     | 47.7     | 45.6     | 47.4     | 50         | 47.1       | 94          | 1.036     | 2   | 70 130      | Passed   |
| 1,1,2-Trichloro-1,2,2-trifluoroethane | 57.4     | 56.8     | 52.9     | 53.6     | 50         | 55.2       | 110         | 2.264     | 4   | 70 - 130    | Passed   |
| 1,2,4-Trimethylbenzene                | 51.5     | 52.0     | 48.2     | 49.2     | 50         | 50.2       | 100         | 1.810     | 4   | 70 130      | Passed   |
| 1,3,5-Trimethylbenzene                | 51.7     | 52.3     | 48.0     | 49.2     | 50         | 50.3       | 101         | 2.016     | 4   | 70 130      | Passed   |
| Vinyl Acetate                         | 65.3     | 59.2     | 58.1     | 58.5     | 50         | 60.3       | 121         | 3.366     | 6   | 50 140      | Passed   |
| Vinyl Chloride                        | 59.8     | 52.9     | 54.5     | 54.5     | 50         | 55.4       | 111         | 3.040     | 5   | 70 140      | Passed   |
| m-Xylene & p-xylene                   | 103      | 105      | 97.0     | 98.7     | 100        | 101.0      | 101         | 3.765     | 4   | 70 130      | Passed   |
| o-Xylene                              | 52.3     | 53.5     | 49.4     | 50.7     | 50         | 51.5       | 103         | 1.786     | 3   | 70 130      | Passed   |
| Allyl Chloride                        | 57.3     | 58.3     | 54.1     | 55.5     | 50         | 56.3       | 113         | 1.869     | 3   | 30 160      | Passed   |

Unit: µg/L  
 Sample Amount(ml): 5  
 Sample Purge(ml): 5  
 Date Analyzed: 01/07/13 & 01/08/13  
 Analyzed by: C. Mendoza

## Appendix 4: DEMONSTRATION OF CAPABILITY for 5 g

DEMONSTRATION OF CAPABILITY  
METHOD: SW 8260

| PARAMETER                   | RCP061   | RCP062   | RCP066   | RCP067   | True Value | Ave. Conc. | Ave. % Rec. | Std. Dev. | RSD | QC Criteria | Comments |
|-----------------------------|----------|----------|----------|----------|------------|------------|-------------|-----------|-----|-------------|----------|
|                             | VO02C04L | VO02C04C | VO02C06L | VO02C06C |            |            |             |           |     |             |          |
| Acetone                     | 259      | 264      | 288      | 281      | 250        | 273        | 109         | 14.006    | 5   | 40 - 140    | Passed   |
| Acetonitrile                | 480      | 506      | 528      | 546      | 500        | 515        | 103         | 28.361    | 6   | 50 - 150    | Passed   |
| Acrylonitrile               | 240      | 245      | 275      | 268      | 250        | 257        | 103         | 17.133    | 7   | 10 - 160    | Passed   |
| Benzene                     | 50.1     | 49.3     | 49.9     | 49.6     | 50         | 49.7       | 99          | 0.364     | 1   | 70 - 130    | Passed   |
| Bromobenzene                | 49.3     | 47.4     | 48.9     | 49.1     | 50         | 48.7       | 97          | 0.838     | 2   | 70 - 130    | Passed   |
| Bromochloromethane          | 52.6     | 53.3     | 55.0     | 56.1     | 50         | 54.2       | 108         | 1.592     | 3   | 70 - 130    | Passed   |
| Bromodichloromethane        | 50.1     | 49.8     | 51.8     | 52.2     | 50         | 51.0       | 102         | 1.207     | 2   | 70 - 130    | Passed   |
| Bromoform                   | 49.2     | 49.2     | 50.3     | 49.6     | 50         | 49.6       | 99          | 0.501     | 1   | 70 - 130    | Passed   |
| Bromomethane                | 46.4     | 46.6     | 45.4     | 46.7     | 50         | 46.3       | 93          | 0.585     | 1   | 60 - 130    | Passed   |
| tert-Butyl alcohol          | 254      | 266      | 274      | 285      | 250        | 270        | 108         | 13.169    | 5   | 40 - 150    | Passed   |
| 2-Butanone (MEK)            | 246      | 251      | 271      | 260      | 250        | 257        | 103         | 11.327    | 4   | 60 - 140    | Passed   |
| n-Butylbenzene              | 53.2     | 51.3     | 52.5     | 53.9     | 50         | 52.7       | 105         | 1.105     | 2   | 70 - 130    | Passed   |
| sec-Butylbenzene            | 52.1     | 51.3     | 51.9     | 52.3     | 50         | 51.9       | 104         | 0.441     | 1   | 70 - 130    | Passed   |
| tert-Butylbenzene           | 48.4     | 48.0     | 48.7     | 49.4     | 50         | 48.6       | 97          | 0.572     | 1   | 70 - 130    | Passed   |
| Carbon disulfide            | 48.1     | 49.8     | 52.1     | 42.5     | 50         | 48.1       | 96          | 4.087     | 8   | 60 - 130    | Passed   |
| Carbon tetrachloride        | 52.5     | 51.2     | 52.2     | 51.2     | 50         | 51.8       | 104         | 0.666     | 1   | 70 - 130    | Passed   |
| Chlorobenzene               | 51.3     | 51.3     | 49.8     | 51.2     | 50         | 50.9       | 102         | 0.728     | 1   | 70 - 130    | Passed   |
| 2-Chloroethyl vinyl ether   | 57.8     | 57.8     | 51.8     | 51.2     | 50         | 54.6       | 109         | 3.681     | 7   | 50 - 140    | Passed   |
| Chloroethane                | 55.0     | 56.1     | 52.3     | 53.3     | 50         | 54.2       | 108         | 1.696     | 3   | 70 - 140    | Passed   |
| Chloroform                  | 55.4     | 55.5     | 53.0     | 54.3     | 50         | 54.5       | 109         | 1.171     | 2   | 70 - 130    | Passed   |
| 1-Chlorohexane              | 53.3     | 51.9     | 51.8     | 52.2     | 50         | 52.3       | 105         | 0.678     | 1   | 70 - 130    | Passed   |
| Chloromethane               | 49.5     | 51.4     | 50.8     | 52.4     | 50         | 51.0       | 102         | 1.201     | 2   | 60 - 130    | Passed   |
| 2-Chlorotoluene             | 44.7     | 48.4     | 45.5     | 48.0     | 50         | 46.6       | 93          | 1.814     | 4   | 70 - 130    | Passed   |
| 4-Chlorotoluene             | 57.2     | 51.0     | 56.4     | 52.5     | 50         | 54.3       | 109         | 3.031     | 6   | 60 - 130    | Passed   |
| Dibromochloromethane        | 49.5     | 49.7     | 51.1     | 52.9     | 50         | 50.8       | 102         | 1.574     | 3   | 70 - 130    | Passed   |
| 1,2-Dibromo-3-chloropropane | 44.9     | 46.0     | 47.8     | 48.2     | 50         | 46.7       | 93          | 1.570     | 3   | 60 - 130    | Passed   |
| 1,2-Dibromoethane           | 47.2     | 48.1     | 50.3     | 50.4     | 50         | 49.0       | 98          | 1.600     | 3   | 70 - 130    | Passed   |
| Dibromomethane              | 48.8     | 48.5     | 49.8     | 50.6     | 50         | 49.4       | 99          | 0.957     | 2   | 70 - 130    | Passed   |
| 1,1-Dichloroethane          | 55.4     | 55.2     | 54.5     | 55.8     | 50         | 55.2       | 110         | 0.518     | 1   | 70 - 130    | Passed   |
| 1,2-Dichloroethane          | 51.3     | 50.9     | 51.7     | 51.1     | 50         | 51.3       | 103         | 0.310     | 1   | 70 - 130    | Passed   |
| 1,2-Dichlorobenzene         | 50.3     | 50.3     | 49.0     | 50.0     | 50         | 49.9       | 100         | 0.602     | 1   | 70 - 130    | Passed   |
| 1,3-Dichlorobenzene         | 50.6     | 50.0     | 50.0     | 50.8     | 50         | 50.3       | 101         | 0.429     | 1   | 70 - 130    | Passed   |
| trans-1,4-Dichloro-2-Butene | 48.8     | 47.7     | 53.8     | 52.2     | 50         | 50.6       | 101         | 2.848     | 6   | 60 - 140    | Passed   |
| 1,4-Dichlorobenzene         | 51.7     | 51.0     | 49.8     | 50.8     | 50         | 50.8       | 102         | 0.775     | 2   | 70 - 130    | Passed   |
| Dichlorodifluoromethane     | 66.9     | 67.2     | 58.9     | 59.2     | 50         | 63.1       | 126         | 4.620     | 7   | 60 - 130    | Passed   |
| 1,1-Dichloroethene          | 51.9     | 53.0     | 52.1     | 54.3     | 50         | 52.8       | 106         | 1.104     | 2   | 60 - 130    | Passed   |
| cis-1,2-Dichloroethene      | 49.5     | 49.2     | 53.0     | 54.8     | 50         | 51.6       | 103         | 2.725     | 5   | 70 - 130    | Passed   |
| trans-1,2-Dichloroethene    | 53.2     | 52.2     | 54.2     | 55.1     | 50         | 53.7       | 107         | 1.267     | 2   | 70 - 130    | Passed   |
| Dichlorofluoromethane       | 49.3     | 51.4     | 53.2     | 56.7     | 50         | 52.6       | 105         | 3.134     | 6   | 70 - 130    | Passed   |
| 1,1-Dichloropropene         | 51.5     | 49.7     | 50.8     | 50.5     | 50         | 50.6       | 101         | 0.753     | 1   | 70 - 130    | Passed   |
| 1,2-Dichloropropane         | 50.5     | 49.7     | 52.0     | 51.8     | 50         | 51.0       | 102         | 1.108     | 2   | 70 - 130    | Passed   |
| 1,3-Dichloropropane         | 47.6     | 47.9     | 50.9     | 51.5     | 50         | 49.5       | 99          | 2.010     | 4   | 70 - 130    | Passed   |
| 2,2-Dichloropropane         | 56.3     | 55.0     | 54.4     | 55.9     | 50         | 55.4       | 111         | 0.857     | 2   | 60 - 140    | Passed   |
| cis-1,3-Dichloropropene     | 51.7     | 51.3     | 52.3     | 52.4     | 50         | 52.0       | 104         | 0.517     | 1   | 70 - 130    | Passed   |

Unit: µg/Kg

Date Analyzed: 03/20 & 03/21/12

Sample Amount(g): 5

Analyzed by: C. Mendoza

Sample Purge(ml): 5

**Appendix 4 (cont.): DEMONSTRATION OF CAPABILITY for 5 g**

DEMONSTRATION OF CAPABILITY  
METHOD: SW 8260

| PARAMETER                             | RCP061   | RCP062   | RCP066   | RCP067   | True Value | Ave. Conc. | Ave. % Rec. | Std. Dev. | RSD | QC Criteria | Comments |
|---------------------------------------|----------|----------|----------|----------|------------|------------|-------------|-----------|-----|-------------|----------|
|                                       | VO02C04L | VO02C04C | VO02C06L | VO02C06C |            |            |             |           |     |             |          |
| trans-1,3-Dichloropropene             | 52.6     | 52.3     | 53.1     | 53.7     | 50         | 52.9       | 106         | 0.623     | 1   | 70 - 130    | Passed   |
| 1,4-Dioxane                           | 878      | 878      | 947      | 958      | 1000       | 915        | 92          | 43.314    | 5   | 50 - 150    | Passed   |
| tert-Butyl ethyl ether (ETBE)         | 54.0     | 53.9     | 54.2     | 55.2     | 50         | 54.3       | 109         | 0.617     | 1   | 70 - 130    | Passed   |
| Ethyl Methacrylate                    | 49.5     | 49.8     | 51.2     | 51.4     | 50         | 50.5       | 101         | 0.964     | 2   | 70 - 130    | Passed   |
| Ethylbenzene                          | 50.5     | 50.8     | 50.7     | 51.3     | 50         | 50.8       | 102         | 0.355     | 1   | 70 - 130    | Passed   |
| 2-Hexanone (MBK)                      | 241      | 247      | 270      | 256      | 250        | 253        | 101         | 12.291    | 5   | 20 - 160    | Passed   |
| Hexachlorobutadiene                   | 52.6     | 48.4     | 49.6     | 49.2     | 50         | 49.9       | 100         | 1.873     | 4   | 70 - 130    | Passed   |
| Iodomethane                           | 61.3     | 61.7     | 50.7     | 52.5     | 50         | 56.6       | 113         | 5.760     | 10  | 60 - 140    | Passed   |
| Isopropyl ether (DIPE)                | 53.2     | 53.2     | 54.7     | 55.5     | 50         | 54.2       | 108         | 1.156     | 2   | 70 - 130    | Passed   |
| Isopropylbenzene                      | 55.9     | 53.8     | 51.7     | 50.4     | 50         | 52.9       | 106         | 2.417     | 5   | 70 - 130    | Passed   |
| p-Isopropyltoluene                    | 53.6     | 52.7     | 51.5     | 51.5     | 50         | 52.3       | 105         | 1.040     | 2   | 70 - 130    | Passed   |
| Methylene Chloride                    | 48.6     | 49.4     | 49.9     | 51.6     | 50         | 49.9       | 100         | 1.276     | 3   | 70 - 130    | Passed   |
| 4-Methyl-2-pentanone (MIBK)           | 243      | 249      | 266      | 253      | 250        | 253        | 101         | 9.792     | 4   | 50 - 150    | Passed   |
| tert-Butyl methyl ether               | 51.2     | 51.8     | 52.3     | 53.4     | 50         | 52.2       | 104         | 0.957     | 2   | 70 - 130    | Passed   |
| Naphthalene                           | 49.7     | 47.2     | 48.9     | 48.7     | 50         | 48.6       | 97          | 1.018     | 2   | 60 - 140    | Passed   |
| n-Propylbenzene                       | 50.2     | 48.4     | 51.1     | 49.9     | 50         | 49.9       | 100         | 1.136     | 2   | 70 - 130    | Passed   |
| Styrene                               | 52.6     | 53.1     | 51.7     | 53.0     | 50         | 52.6       | 105         | 0.637     | 1   | 70 - 130    | Passed   |
| tert-Amyl methyl ether (TAME)         | 51.9     | 52.9     | 52.4     | 53.9     | 50         | 52.8       | 106         | 0.850     | 2   | 70 - 130    | Passed   |
| 1,1,1,2-Tetrachloroethane             | 50.7     | 51.8     | 50.8     | 52.0     | 50         | 51.3       | 103         | 0.670     | 1   | 70 - 130    | Passed   |
| 1,1,2,2-Tetrachloroethane             | 48.3     | 48.6     | 50.5     | 49.7     | 50         | 49.3       | 99          | 1.013     | 2   | 70 - 130    | Passed   |
| Tetrachloroethene                     | 52.5     | 50.5     | 50.0     | 50.2     | 50         | 50.8       | 102         | 1.184     | 2   | 70 - 130    | Passed   |
| Toluene                               | 49.9     | 49.3     | 50.1     | 50.1     | 50         | 49.9       | 100         | 0.359     | 1   | 70 - 130    | Passed   |
| 1,1,1-Trichloroethane                 | 55.4     | 55.0     | 53.7     | 54.8     | 50         | 54.7       | 109         | 0.756     | 1   | 70 - 130    | Passed   |
| 1,1,2-Trichloroethane                 | 49.6     | 49.4     | 50.3     | 51.7     | 50         | 50.2       | 100         | 1.049     | 2   | 70 - 130    | Passed   |
| 1,2,3-Trichlorobenzene                | 52.9     | 49.1     | 50.9     | 50.8     | 50         | 50.9       | 102         | 1.545     | 3   | 70 - 130    | Passed   |
| 1,2,4-Trichlorobenzene                | 56.6     | 52.9     | 52.3     | 54.2     | 50         | 54.0       | 108         | 1.911     | 4   | 70 - 140    | Passed   |
| Trichloroethene                       | 51.4     | 50.6     | 49.6     | 49.4     | 50         | 50.3       | 101         | 0.955     | 2   | 70 - 130    | Passed   |
| Trichlorofluoromethane                | 63.3     | 61.5     | 57.5     | 55.8     | 50         | 59.6       | 119         | 3.486     | 6   | 70 - 140    | Passed   |
| 1,2,3-Trichloropropane                | 45.2     | 45.3     | 48.9     | 48.3     | 50         | 46.9       | 94          | 1.942     | 4   | 70 - 130    | Passed   |
| 1,1,2-Trichloro-1,2,2-trifluoroethane | 57.2     | 58.5     | 50.7     | 54.4     | 50         | 55.2       | 110         | 3.450     | 6   | 70 - 140    | Passed   |
| 1,2,4-Trimethylbenzene                | 52.6     | 51.3     | 51.3     | 51.4     | 50         | 51.7       | 103         | 0.647     | 1   | 70 - 130    | Passed   |
| 1,3,5-Trimethylbenzene                | 50.7     | 49.9     | 51.0     | 51.1     | 50         | 50.7       | 101         | 0.516     | 1   | 70 - 130    | Passed   |
| Vinyl Acetate                         | 50.9     | 47.8     | 59.8     | 57.1     | 50         | 53.9       | 108         | 5.524     | 10  | 20 - 160    | Passed   |
| Vinyl Chloride                        | 55.2     | 57.3     | 51.7     | 52.9     | 50         | 54.3       | 109         | 2.495     | 5   | 60 - 140    | Passed   |
| m-Xylene & p-xylene                   | 102      | 101      | 101      | 104      | 100        | 102.0      | 102         | 1.343     | 1   | 70 - 130    | Passed   |
| o-Xylene                              | 49.9     | 50.3     | 51.3     | 52.6     | 50         | 51.0       | 102         | 1.217     | 2   | 70 - 130    | Passed   |

Unit: µg/Kg

Date Analyzed: 03/20 & 03/21/12

Sample Amount(g): 5

Analyzed by: C. Mendoza

Sample Purge(ml): 5





8260FA:

ANALYTICAL RUN LOG



Page 1

ANALYSIS LOG FOR VOLATILES

SOP  EMAX-8260 Rev.No. \_  EMAX-624 Rev.No. \_  EMAX-8260SIM Rev.No. \_  EMAX-TCP5IM Rev.No. \_  EMAX-M8260SIM Rev.No. \_  EMAX-8260C Rev. No. \_

Start Date:  5-mL Purge  10-mL Purge  25-mL Purge

Book # A06 -053

| Sample<br>Prep<br>ID | Data<br>File Name | Lab Sample ID | Sample<br>Amount | DF | Matrix    |                           |   | Notes | Instrument No. 06                                   |       |                |                 |
|----------------------|-------------------|---------------|------------------|----|-----------|---------------------------|---|-------|---|-------|----------------|-----------------|
|                      |                   |               |                  |    | W         |                           | S |       | INITIAL CALIBRATION REFERENCE                       |       |                |                 |
|                      |                   |               |                  |    | pH<br>< 2 | Cl <sub>2</sub><br>< 5ppm |   |       | DATE  |       |                |                 |
| 01                   |                   |               |                  |    |           |                           |   |       | ICAL ID   |       |                |                 |
| 02                   |                   |               |                  |    |           |                           |   |       | STANDARDS   |       |                |                 |
| 03                   |                   |               |                  |    |           |                           |   |       | NAME  | ID    | Amount<br>(µl) | Conc.<br>(mg/L) |
| 04                   |                   |               |                  |    |           |                           |   |       | DCC   |       |                |                 |
| 05                   |                   |               |                  |    |           |                           |   |       | DCC   |       |                |                 |
| 06                   |                   |               |                  |    |           |                           |   |       | DCC   |       |                |                 |
| 07                   |                   |               |                  |    |           |                           |   |       | DCC   |       |                |                 |
| 08                   |                   |               |                  |    |           |                           |   |       | BFB   |       |                |                 |
| 09                   |                   |               |                  |    |           |                           |   |       | IS/SURR.  |       |                |                 |
| 10                   |                   |               |                  |    |           |                           |   |       | ICV/LCS   |       |                |                 |
| 11                   |                   |               |                  |    |           |                           |   |       | ICV/LCS   |       |                |                 |
| 12                   |                   |               |                  |    |           |                           |   |       | ICV/LCS   |       |                |                 |
| 13                   |                   |               |                  |    |           |                           |   |       | ICV/LCS   |       |                |                 |
| 14                   |                   |               |                  |    |           |                           |   |       | Data File Folder                                    |       |                |                 |
| 15                   |                   |               |                  |    |           |                           |   |       |   | LOT # |                |                 |
| 16                   |                   |               |                  |    |           |                           |   |       | pH strip  |       |                |                 |
| 17                   |                   |               |                  |    |           |                           |   |       | Chlorine strip                                      |       |                |                 |
| 18                   |                   |               |                  |    |           |                           |   |       | Methanol  |       |                |                 |
| 19                   |                   |               |                  |    |           |                           |   |       | NaHSO <sub>4</sub>                                  |       |                |                 |
| 20                   |                   |               |                  |    |           |                           |   |       | Reagent Water                                       |       |                |                 |
| 21                   |                   |               |                  |    |           |                           |   |       | Sand  |       |                |                 |
| 22                   |                   |               |                  |    |           |                           |   |       | Electronic Data Archival Location                   |       | Date           |                 |
| 23                   |                   |               |                  |    |           |                           |   |       | HPCHEM_VOA/TO06                                     |       |                |                 |
| 24                   |                   |               |                  |    |           |                           |   |       | Comments:   |       |                |                 |
| 25                   |                   |               |                  |    |           |                           |   |       |   |       |                |                 |
| 26                   |                   |               |                  |    |           |                           |   |       |   |       |                |                 |
| 27                   |                   |               |                  |    |           |                           |   |       |   |       |                |                 |
| 28                   |                   |               |                  |    |           |                           |   |       | <input type="checkbox"/> Refer to sample weight log |       |                |                 |
| 29                   |                   |               |                  |    |           |                           |   |       | Analyzed By:  |       |                |                 |
| 30                   |                   |               |                  |    |           |                           |   |       | Date Disposed:                                      |       | Disposed By:   |                 |

BATCH





**LABORATORIES, INC.**  
 1835 W. 205th Street  
 Torrance, CA 90501  
 Tel: (310) 618-8889  
 Fax: (310) 618-0818

ERRATUM TO

|                  |                    |
|------------------|--------------------|
| Document         | EMAX-8270          |
| Revision Number  | 6                  |
| Section          | Forms: Table 8     |
| Date             | September 20, 2016 |
| Reference Number | 8270.6.2           |

Page 1 of 4

Table 8 shall read as attached.

PREPARED BY:  Date: 09-20-16

Name Tu Nisamaneepong  
 Title Operations Manager

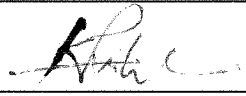
APPROVED BY:  Date: 09-20-16

Name Kenette Pimentel  
 Title QA Manager

APPROVED BY:  Date: 09-20-16

Name Caspar Pang  
 Title Laboratory Director

**Table 8: TYPICAL TARGET ANALYTE LIST FOR REGULAR LIST**

| Analyte                       | Quantitation Ions |           | IS  | SUR    | ICAL ANALYTE CONCENTRATIONS (µg/L) |    |    |    |    |    |    |     | ICV/DCC<br>EV(µg/L) | LCS/MS<br>EV(µg/L) | WATER |     |     |      | SOIL |     |      |       |
|-------------------------------|-------------------|-----------|-----|--------|------------------------------------|----|----|----|----|----|----|-----|---------------------|--------------------|-------|-----|-----|------|------|-----|------|-------|
|                               | Primary           | Secondary |     |        | 1                                  | 2  | 3  | 4  | 5  | 6  | 7  | 8   |                     |                    | DL    | LOD | LOQ | Unit | DL   | LOD | LOQ  | Unit  |
| Acenaphthene                  | 153               | 152       | IS3 | Sur4   | 4                                  | 10 | 20 | 25 | 40 | 50 |    |     | 25                  | 40                 | 2.5   | 5   | 10  | µg/L | 83   | 167 | 333  | µg/Kg |
| Acenaphthylene                | 152               | 151       | IS3 | Sur4   | 4                                  | 10 | 20 | 25 | 40 | 50 |    |     | 25                  | 40                 | 2.5   | 5   | 10  | µg/L | 83   | 167 | 333  | µg/Kg |
| Aniline                       | 93                | 66        | IS1 | Sur3   | 4                                  | 10 | 20 | 25 | 40 | 50 |    |     | 25                  | 40                 | 5.3   | 10  | 20  | µg/L | 83   | 167 | 667  | µg/Kg |
| Anthracene                    | 178               | 152       | IS4 | Sur4/6 | 4                                  | 10 | 20 | 25 | 40 | 50 |    |     | 25                  | 40                 | 2.5   | 5   | 10  | µg/L | 83   | 167 | 333  | µg/Kg |
| Azobenzene*                   | 77                | 105       | IS4 | Sur4/6 | 4                                  | 10 | 20 | 25 | 40 | 50 |    |     | 25                  | 40                 | 2.5   | 5   | 10  | µg/L | 96   | 167 | 333  | µg/Kg |
| Benzo(a)anthracene            | 228.1             | 113       | IS5 | Sur6   | 4                                  | 10 | 20 | 25 | 40 | 50 |    |     | 25                  | 40                 | 2.5   | 5   | 10  | µg/L | 83   | 167 | 333  | µg/Kg |
| Benzo(a)pyrene                | 252.1             | 125       | IS6 | Sur6   | 4                                  | 10 | 20 | 25 | 40 | 50 |    |     | 25                  | 40                 | 2.5   | 5   | 10  | µg/L | 83   | 167 | 333  | µg/Kg |
| Benzo(b)fluoranthene          | 252.1             | 124.9     | IS6 | Sur6   | 4                                  | 10 | 20 | 25 | 40 | 50 |    |     | 25                  | 40                 | 2.6   | 5   | 10  | µg/L | 86   | 167 | 333  | µg/Kg |
| Benzo(e)pyrene                | 252.1             | 125       | IS6 | Sur6   | 4                                  | 10 | 20 | 25 | 40 | 50 |    |     | 25                  | 40                 | 2.5   | 5   | 10  | µg/L | 83   | 167 | 333  | µg/Kg |
| Benzo(g,h,i)perylene          | 276.1             | 137.9     | IS6 | Sur6   | 4                                  | 10 | 20 | 25 | 40 | 50 |    |     | 25                  | 40                 | 2.5   | 5   | 10  | µg/L | 87   | 167 | 333  | µg/Kg |
| Benzo(k)fluoranthene          | 252.1             | 124.9     | IS6 | Sur6   | 4                                  | 10 | 20 | 25 | 40 | 50 |    |     | 25                  | 40                 | 2.5   | 5   | 10  | µg/L | 83   | 167 | 333  | µg/Kg |
| Benzoic acid                  | 105               | 77        | IS2 | Sur1/2 | 4                                  | 10 | 20 | 25 | 40 | 50 | 80 | 100 | 25                  | 80                 | 10    | 20  | 40  | µg/L | 333  | 667 | 1333 | µg/Kg |
| Benzyl alcohol                | 108               | 79        | IS1 | Sur3   | 4                                  | 10 | 20 | 25 | 40 | 50 |    |     | 25                  | 40                 | 2.5   | 5   | 10  | µg/L | 83   | 167 | 333  | µg/Kg |
| Biphenyl                      | 154               | 153       | IS3 | Sur4   | 4                                  | 10 | 20 | 25 | 40 | 50 |    |     | 25                  | 40                 | 2.5   | 5   | 10  | µg/L | 83   | 167 | 333  | µg/Kg |
| Bis (2-Chloroethoxy) methane  | 92.9              | 94.9      | IS2 | Sur3   | 4                                  | 10 | 20 | 25 | 40 | 50 |    |     | 25                  | 40                 | 2.5   | 5   | 10  | µg/L | 83   | 167 | 333  | µg/Kg |
| Bis (2-Chloroethyl) ether     | 92.9              | 62.9      | IS1 | Sur3   | 4                                  | 10 | 20 | 25 | 40 | 50 |    |     | 25                  | 40                 | 2.5   | 5   | 10  | µg/L | 83   | 167 | 333  | µg/Kg |
| Bis (2-chloroisopropyl) ether | 45                | 76.9      | IS1 | Sur3   | 4                                  | 10 | 20 | 25 | 40 | 50 |    |     | 25                  | 40                 | 2.5   | 5   | 10  | µg/L | 83   | 167 | 333  | µg/Kg |
| Bis(2-ethylhexyl)adipate      | 129               | 57        | IS5 | Sur6   | 4                                  | 10 | 20 | 25 | 40 | 50 |    |     | 25                  | 40                 | 2.5   | 5   | 10  | µg/L | 87   | 167 | 333  | µg/Kg |
| bis(2-Ethylhexyl)phthalate    | 149               | 167       | IS5 | Sur6   | 4                                  | 10 | 20 | 25 | 40 | 50 |    |     | 25                  | 40                 | 2.5   | 5   | 10  | µg/L | 115  | 167 | 333  | µg/Kg |
| 4-Bromophenyl-phenylether     | 247.9             | 250       | IS4 | Sur4/6 | 4                                  | 10 | 20 | 25 | 40 | 50 |    |     | 25                  | 40                 | 2.5   | 5   | 10  | µg/L | 90   | 167 | 333  | µg/Kg |
| Butylbenzylphthalate          | 149               | 91        | IS5 | Sur6   | 4                                  | 10 | 20 | 25 | 40 | 50 |    |     | 25                  | 40                 | 2.5   | 5   | 10  | µg/L | 83   | 167 | 333  | µg/Kg |
| Carbazole                     | 167               | 139       | IS4 | Sur4/6 | 4                                  | 10 | 20 | 25 | 40 | 50 |    |     | 25                  | 40                 | 2.5   | 5   | 10  | µg/L | 89   | 167 | 333  | µg/Kg |
| 4-Chloro-3-methylphenol       | 107               | 77        | IS2 | Sur1/2 | 4                                  | 10 | 20 | 25 | 40 | 50 |    |     | 25                  | 40                 | 2.5   | 5   | 10  | µg/L | 83   | 167 | 333  | µg/Kg |
| 4-Chloroaniline               | 127               | 129       | IS2 | Sur3   | 4                                  | 10 | 20 | 25 | 40 | 50 |    |     | 25                  | 40                 | 4.2   | 5   | 10  | µg/L | 83   | 167 | 333  | µg/Kg |
| 2-Chloronaphthalene           | 162               | 164       | IS3 | Sur4   | 4                                  | 10 | 20 | 25 | 40 | 50 |    |     | 25                  | 40                 | 2.5   | 5   | 10  | µg/L | 83   | 167 | 333  | µg/Kg |
| 2-Chlorophenol                | 127.9             | 64        | IS1 | Sur1/2 | 4                                  | 10 | 20 | 25 | 40 | 50 |    |     | 25                  | 40                 | 2.5   | 5   | 10  | µg/L | 83   | 167 | 333  | µg/Kg |
| 4-Chlorophenyl-phenylether    | 204               | 206       | IS3 | Sur4   | 4                                  | 10 | 20 | 25 | 40 | 50 |    |     | 25                  | 40                 | 2.5   | 5   | 10  | µg/L | 83   | 167 | 333  | µg/Kg |
| Chrysene                      | 228.1             | 226.1     | IS5 | Sur6   | 4                                  | 10 | 20 | 25 | 40 | 50 |    |     | 25                  | 40                 | 2.5   | 5   | 10  | µg/L | 83   | 167 | 333  | µg/Kg |
| Dibenzo(a,h)anthracene        | 278.1             | 139       | IS6 | Sur6   | 4                                  | 10 | 20 | 25 | 40 | 50 |    |     | 25                  | 40                 | 2.5   | 5   | 10  | µg/L | 83   | 167 | 333  | µg/Kg |
| Dibenzofuran                  | 168               | 139       | IS3 | Sur4   | 4                                  | 10 | 20 | 25 | 40 | 50 |    |     | 25                  | 40                 | 2.5   | 5   | 10  | µg/L | 83   | 167 | 333  | µg/Kg |
| 1,2-Dichlorobenzene           | 145.9             | 147.9     | IS1 | Sur3   | 4                                  | 10 | 20 | 25 | 40 | 50 |    |     | 25                  | 40                 | 2.5   | 5   | 10  | µg/L | 83   | 167 | 333  | µg/Kg |
| 1,3-Dichlorobenzene           | 145.9             | 147.9     | IS1 | Sur3   | 4                                  | 10 | 20 | 25 | 40 | 50 |    |     | 25                  | 40                 | 2.5   | 5   | 10  | µg/L | 83   | 167 | 333  | µg/Kg |
| 1,4-Dichlorobenzene           | 145.9             | 147.9     | IS1 | Sur3   | 4                                  | 10 | 20 | 25 | 40 | 50 |    |     | 25                  | 40                 | 2.5   | 5   | 10  | µg/L | 83   | 167 | 333  | µg/Kg |
| 3,3'-Dichlorobenzidine        | 252               | 254       | IS5 | Sur6   | 4                                  | 10 | 20 | 25 | 40 | 50 |    |     | 25                  | 40                 | 2.5   | 5   | 10  | µg/L | 84   | 167 | 333  | µg/Kg |
| 2,4-Dichlorophenol            | 161.9             | 163.9     | IS2 | Sur1/2 | 4                                  | 10 | 20 | 25 | 40 | 50 |    |     | 25                  | 40                 | 2.5   | 5   | 10  | µg/L | 83   | 167 | 333  | µg/Kg |
| Diethylphthalate              | 149               | 177       | IS3 | Sur4   | 4                                  | 10 | 20 | 25 | 40 | 50 |    |     | 25                  | 40                 | 2.5   | 5   | 10  | µg/L | 83   | 167 | 333  | µg/Kg |
| 2,6-Dimethylnaphthalene       | 156               | 141       | IS3 | Sur4   | 4                                  | 10 | 20 | 25 | 40 | 50 |    |     | 25                  | 40                 | 2.5   | 5   | 10  | µg/L | 83   | 167 | 333  | µg/Kg |
| 2,4-Dimethylphenol            | 107               | 122       | IS2 | Sur1/2 | 4                                  | 10 | 20 | 25 | 40 | 50 |    |     | 25                  | 40                 | 2.6   | 5   | 10  | µg/L | 83   | 167 | 333  | µg/Kg |
| 3,4-Dimethylphenol            | 107               | 122       | IS2 | Sur1/2 | 4                                  | 10 | 20 | 25 | 40 | 50 |    |     | 25                  | 40                 | 2.5   | 5   | 10  | µg/L | 83   | 167 | 333  | µg/Kg |
| Dimethylphthalate             | 163               | 164       | IS3 | Sur4   | 4                                  | 10 | 20 | 25 | 40 | 50 |    |     | 25                  | 40                 | 2.5   | 5   | 10  | µg/L | 83   | 167 | 333  | µg/Kg |
| Di-n-butylphthalate           | 149               | 150       | IS4 | Sur4/6 | 4                                  | 10 | 20 | 25 | 40 | 50 |    |     | 25                  | 40                 | 2.5   | 5   | 10  | µg/L | 97   | 167 | 333  | µg/Kg |

**Table 8: TYPICAL TARGET ANALYTE LIST FOR REGULAR LIST**

| Analyte                    | Quantitation Ions |           | IS  | SUR    | ICAL ANALYTE CONCENTRATIONS (µg/L) |    |    |    |    |    |    |     | ICV/DCC<br>EV(µg/L) | LCS/MS<br>EV(µg/L) | WATER |     |     |      | SOIL |     |      |       |
|----------------------------|-------------------|-----------|-----|--------|------------------------------------|----|----|----|----|----|----|-----|---------------------|--------------------|-------|-----|-----|------|------|-----|------|-------|
|                            | Primary           | Secondary |     |        | 1                                  | 2  | 3  | 4  | 5  | 6  | 7  | 8   |                     |                    | DL    | LOD | LOQ | Unit | DL   | LOD | LOQ  | Unit  |
| 4,6-Dinitro-2-methylphenol | 198               | 121       | IS4 | Sur5   | 4                                  | 10 | 20 | 25 | 40 | 50 |    |     | 25                  | 40                 | 2.5   | 5   | 10  | µg/L | 83   | 167 | 333  | µg/Kg |
| 1,3-Dinitrobenzene         | 168               | 75        | IS3 | Sur4   | 4                                  | 10 | 20 | 25 | 40 | 50 |    |     | 25                  | 40                 | 2.5   | 5   | 10  | µg/L | 83   | 167 | 333  | µg/Kg |
| 2,4-Dinitrophenol          | 184               | 106.9     | IS3 | Sur5   | 4                                  | 10 | 20 | 25 | 40 | 50 |    |     | 25                  | 40                 | 2.5   | 5   | 10  | µg/L | 86   | 167 | 333  | µg/Kg |
| 2,4-Dinitrotoluene         | 165               | 89        | IS3 | Sur4   | 4                                  | 10 | 20 | 25 | 40 | 50 |    |     | 25                  | 40                 | 2.5   | 5   | 10  | µg/L | 83   | 167 | 333  | µg/Kg |
| 2,6-Dinitrotoluene         | 165               | 89        | IS3 | Sur4   | 4                                  | 10 | 20 | 25 | 40 | 50 |    |     | 25                  | 40                 | 2.5   | 5   | 10  | µg/L | 83   | 167 | 333  | µg/Kg |
| Di-n-octylphthalate        | 149               | 150       | IS6 | Sur6   | 4                                  | 10 | 20 | 25 | 40 | 50 |    |     | 25                  | 40                 | 2.5   | 5   | 10  | µg/L | 97   | 167 | 333  | µg/Kg |
| Fluoranthene               | 202               | 100.9     | IS4 | Sur4/6 | 4                                  | 10 | 20 | 25 | 40 | 50 |    |     | 25                  | 40                 | 2.5   | 5   | 10  | µg/L | 126  | 167 | 333  | µg/Kg |
| Fluorene                   | 166               | 165       | IS3 | Sur4   | 4                                  | 10 | 20 | 25 | 40 | 50 |    |     | 25                  | 40                 | 2.5   | 5   | 10  | µg/L | 83   | 167 | 333  | µg/Kg |
| Hexachlorobenzene          | 283.8             | 141.9     | IS4 | Sur4/6 | 4                                  | 10 | 20 | 25 | 40 | 50 |    |     | 25                  | 40                 | 2.5   | 5   | 10  | µg/L | 83   | 167 | 333  | µg/Kg |
| Hexachlorobutadiene        | 224.8             | 222.8     | IS2 | Sur3   | 4                                  | 10 | 20 | 25 | 40 | 50 |    |     | 25                  | 40                 | 2.5   | 5   | 10  | µg/L | 83   | 167 | 333  | µg/Kg |
| Hexachlorocyclopentadiene  | 236.8             | 234.8     | IS3 | Sur4   | 4                                  | 10 | 20 | 25 | 40 | 50 |    |     | 25                  | 40                 | 2.5   | 5   | 10  | µg/L | 83   | 167 | 333  | µg/Kg |
| Hexachloroethane           | 116.8             | 200.8     | IS1 | Sur3   | 4                                  | 10 | 20 | 25 | 40 | 50 |    |     | 25                  | 40                 | 2.5   | 5   | 10  | µg/L | 83   | 167 | 333  | µg/Kg |
| Indeno(1,2,3-cd)pyrene     | 276.1             | 137.9     | IS6 | Sur6   | 4                                  | 10 | 20 | 25 | 40 | 50 |    |     | 25                  | 40                 | 2.5   | 5   | 10  | µg/L | 83   | 167 | 333  | µg/Kg |
| Isophorone                 | 82                | 138       | IS2 | Sur3   | 4                                  | 10 | 20 | 25 | 40 | 50 |    |     | 25                  | 40                 | 2.5   | 5   | 10  | µg/L | 83   | 167 | 333  | µg/Kg |
| 1-Methylnaphthalene        | 142               | 141       | IS2 | Sur3   | 4                                  | 10 | 20 | 25 | 40 | 50 |    |     | 25                  | 40                 | 2.5   | 5   | 10  | µg/L | 83   | 167 | 333  | µg/Kg |
| 2-Methylnaphthalene        | 142               | 141       | IS2 | Sur3   | 4                                  | 10 | 20 | 25 | 40 | 50 |    |     | 25                  | 40                 | 2.5   | 5   | 10  | µg/L | 83   | 167 | 333  | µg/Kg |
| 1-Methylphenanthrene       | 192.1             | 165       | IS4 | Sur4/6 | 4                                  | 10 | 20 | 25 | 40 | 50 |    |     | 25                  | 40                 | 2.5   | 5   | 10  | µg/L | 83   | 167 | 333  | µg/Kg |
| 2-Methylphenol             | 107               | 108       | IS1 | Sur1/2 | 4                                  | 10 | 20 | 25 | 40 | 50 |    |     | 25                  | 40                 | 2.5   | 5   | 10  | µg/L | 83   | 167 | 333  | µg/Kg |
| 4-Methylphenol             | 107               | 108       | IS1 | Sur1/2 | 4                                  | 10 | 20 | 25 | 40 | 50 |    |     | 25                  | 40                 | 2.5   | 5   | 10  | µg/L | 83   | 167 | 333  | µg/Kg |
| Naphthalene                | 128               | 129       | IS2 | Sur3   | 4                                  | 10 | 20 | 25 | 40 | 50 |    |     | 25                  | 40                 | 2.5   | 5   | 10  | µg/L | 83   | 167 | 333  | µg/Kg |
| 2-Nitroaniline             | 65                | 92        | IS3 | Sur4   | 4                                  | 10 | 20 | 25 | 40 | 50 |    |     | 25                  | 40                 | 2.5   | 5   | 10  | µg/L | 83   | 167 | 333  | µg/Kg |
| 3-Nitroaniline             | 138               | 92        | IS3 | Sur4   | 4                                  | 10 | 20 | 25 | 40 | 50 |    |     | 25                  | 40                 | 2.5   | 5   | 10  | µg/L | 83   | 167 | 333  | µg/Kg |
| 4-Nitroaniline             | 138               | 92        | IS3 | Sur4   | 4                                  | 10 | 20 | 25 | 40 | 50 |    |     | 25                  | 40                 | 2.5   | 5   | 10  | µg/L | 120  | 167 | 333  | µg/Kg |
| Nitrobenzene               | 77                | 123       | IS2 | Sur3   | 4                                  | 10 | 20 | 25 | 40 | 50 |    |     | 25                  | 40                 | 2.5   | 5   | 10  | µg/L | 83   | 167 | 333  | µg/Kg |
| 2-Nitrophenol              | 139               | 65        | IS2 | Sur1/2 | 4                                  | 10 | 20 | 25 | 40 | 50 |    |     | 25                  | 40                 | 2.5   | 5   | 10  | µg/L | 83   | 167 | 333  | µg/Kg |
| 4-Nitrophenol              | 109               | 139       | IS3 | Sur5   | 4                                  | 10 | 20 | 25 | 40 | 50 |    |     | 25                  | 40                 | 2.5   | 5   | 10  | µg/L | 106  | 167 | 667  | µg/Kg |
| N-nitrosodimethylamine     | 74                | 42        | IS1 | Sur3   | 4                                  | 10 | 20 | 25 | 40 | 50 |    |     | 25                  | 40                 | 2.5   | 5   | 10  | µg/L | 83   | 167 | 333  | µg/Kg |
| N-Nitroso-di-n-propylamine | 70                | 42        | IS1 | Sur3   | 4                                  | 10 | 20 | 25 | 40 | 50 |    |     | 25                  | 40                 | 2.5   | 5   | 10  | µg/L | 83   | 167 | 333  | µg/Kg |
| N-Nitrosodiphenylamine     | 169               | 168       | IS4 | Sur4/6 | 4                                  | 10 | 20 | 25 | 40 | 50 |    |     | 25                  | 40                 | 2.5   | 5   | 10  | µg/L | 153  | 167 | 333  | µg/Kg |
| Pentachlorophenol          | 265.8             | 164.9     | IS4 | Sur5   | 4                                  | 10 | 20 | 25 | 40 | 50 |    |     | 25                  | 40                 | 2.5   | 5   | 10  | µg/L | 83   | 167 | 667  | µg/Kg |
| Perylene                   | 252.1             | 125       | IS6 | Sur6   | 4                                  | 10 | 20 | 25 | 40 | 50 |    |     | 25                  | 40                 | 2.5   | 5   | 10  | µg/L | 86   | 167 | 333  | µg/Kg |
| Phenanthrene               | 178               | 152       | IS4 | Sur4/6 | 4                                  | 10 | 20 | 25 | 40 | 50 |    |     | 25                  | 40                 | 2.5   | 5   | 10  | µg/L | 83   | 167 | 333  | µg/Kg |
| Phenol                     | 94                | 65        | IS1 | Sur1/2 | 4                                  | 10 | 20 | 25 | 40 | 50 |    |     | 25                  | 40                 | 2.5   | 5   | 10  | µg/L | 83   | 167 | 333  | µg/Kg |
| Pyrene                     | 202               | 100.9     | IS5 | Sur6   | 4                                  | 10 | 20 | 25 | 40 | 50 |    |     | 25                  | 40                 | 2.5   | 5   | 10  | µg/L | 160  | 167 | 333  | µg/Kg |
| Pyridine                   | 79                | 52        | IS1 | Sur3   | 4                                  | 10 | 20 | 25 | 40 | 50 | 80 | 100 | 25                  | 80                 | 11    | 20  | 40  | µg/L | 333  | 667 | 1333 | µg/Kg |
| 2,3,4,6-Tetrachlorophenol  | 231.8             | 229.8     | IS3 | Sur5   | 4                                  | 10 | 20 | 25 | 40 | 50 |    |     | 25                  | 40                 | 3.6   | 5   | 10  | µg/L | 100  | 167 | 333  | µg/Kg |
| 1,2,4-Trichlorobenzene     | 179.9             | 181.9     | IS2 | Sur3   | 4                                  | 10 | 20 | 25 | 40 | 50 |    |     | 25                  | 40                 | 2.5   | 5   | 10  | µg/L | 83   | 167 | 333  | µg/Kg |
| 2,3,4-Trichlorophenol      | 195.9             | 96.9      | IS3 | Sur5   | 4                                  | 10 | 20 | 25 | 40 | 50 |    |     | 25                  | 40                 | 2.5   | 5   | 10  | µg/L | 83   | 167 | 333  | µg/Kg |
| 2,3,5-Trichlorophenol      | 195.9             | 96.9      | IS3 | Sur5   | 4                                  | 10 | 20 | 25 | 40 | 50 |    |     | 25                  | 40                 | 2.5   | 5   | 10  | µg/L | 165  | 167 | 333  | µg/Kg |
| 2,4,5-Trichlorophenol      | 195.9             | 197.9     | IS3 | Sur5   | 4                                  | 10 | 20 | 25 | 40 | 50 |    |     | 25                  | 40                 | 2.5   | 5   | 10  | µg/L | 91   | 167 | 333  | µg/Kg |
| 2,4,6-Trichlorophenol      | 195.9             | 197.9     | IS3 | Sur5   | 4                                  | 10 | 20 | 25 | 40 | 50 |    |     | 25                  | 40                 | 2.5   | 5   | 10  | µg/L | 83   | 167 | 333  | µg/Kg |

**Table 8: TYPICAL TARGET ANALYTE LIST FOR REGULAR LIST**

| Analyte                      | Quantitation Ions |           | IS    | SUR  | ICAL ANALYTE CONCENTRATIONS (µg/L) |    |    |    |    |    |     |   | ICV/DCC<br>EV(µg/L) | LCS/MS<br>EV(µg/L) | WATER |     |      |      | SOIL |     |      |       |
|------------------------------|-------------------|-----------|-------|------|------------------------------------|----|----|----|----|----|-----|---|---------------------|--------------------|-------|-----|------|------|------|-----|------|-------|
|                              | Primary           | Secondary |       |      | 1                                  | 2  | 3  | 4  | 5  | 6  | 7   | 8 |                     |                    | DL    | LOD | LOQ  | Unit | DL   | LOD | LOQ  | Unit  |
| 2,3,5-Trimethylnaphthalene   | 171.1             | 155       | IS3   | Sur4 | 4                                  | 10 | 20 | 25 | 40 | 50 |     |   | 25                  | 40                 | 2.5   | 5   | 10   | µg/L | 83   | 167 | 333  | µg/Kg |
| Benzidine                    | 184               | 92        | IS1/4 | Sur6 | 4                                  | 10 | 25 | 40 | 50 | 80 | 100 |   | 25                  | 80                 | 10    | 20  | 50   | µg/L | 863  | 867 | 1333 | µg/Kg |
| 2-Fluorophenol (Sur1)        | 112               | 64        | IS1   |      | 4                                  | 10 | 20 | 25 | 40 | 50 |     |   | 25                  | 40                 | 1.5   | 3   | 5    | µg/L | 61   | 100 | 167  | µg/Kg |
| Phenol-d5 (Sur2)             | 99                | 71        | IS1   |      | 4                                  | 10 | 20 | 25 | 40 | 50 |     |   | 25                  | 40                 | 1.5   | 3   | 5    | µg/L | 52   | 100 | 167  | µg/Kg |
| Nitrobenzene-d5 (Sur3)       | 82                | 128       | IS2   |      | 4                                  | 10 | 20 | 25 | 40 | 50 |     |   | 25                  | 40                 | 0.59  | 1   | 1.67 | µg/L | 17   | 33  | 56   | µg/Kg |
| 2-Fluorobiphenyl (Sur4)      | 172               | 171       | IS3   |      | 4                                  | 10 | 20 | 25 | 40 | 50 |     |   | 25                  | 40                 | 0.5   | 1   | 1.67 | µg/L | 24   | 33  | 56   | µg/Kg |
| 2,4,6-Tribromophenol (Sur5)  | 329.8             | 331.8     | IS4   |      | 4                                  | 10 | 20 | 25 | 40 | 50 |     |   | 25                  | 40                 | 1.5   | 3   | 5    | µg/L | 55   | 100 | 167  | µg/Kg |
| Terphenyl-d14 (Sur6)         | 244.2             | 122       | IS5   |      | 4                                  | 10 | 20 | 25 | 40 | 50 |     |   | 25                  | 40                 | 0.54  | 1   | 1.67 | µg/L | 24   | 33  | 56   | µg/Kg |
| 1,4-Dichlorobenzene-d4 (IS1) | 151.9             | 115       |       |      |                                    |    |    |    |    |    |     |   |                     |                    |       |     |      |      |      |     |      |       |
| Naphtalene-d8 (IS2)          | 136               | 68        |       |      |                                    |    |    |    |    |    |     |   |                     |                    |       |     |      |      |      |     |      |       |
| Acenaphthene-d10 (IS3)       | 164.1             | 162.1     |       |      |                                    |    |    |    |    |    |     |   |                     |                    |       |     |      |      |      |     |      |       |
| Phenanthrene-d10 (IS4)       | 188.1             | 94        |       |      |                                    |    |    |    |    |    |     |   |                     |                    |       |     |      |      |      |     |      |       |
| Chrysene-d12 (IS5)           | 240.1             | 120       |       |      |                                    |    |    |    |    |    |     |   |                     |                    |       |     |      |      |      |     |      |       |
| Perylene-d12 (IS6)           | 264.1             | 130       |       |      |                                    |    |    |    |    |    |     |   |                     |                    |       |     |      |      |      |     |      |       |

## Notes:

1. PSR supersedes Table 8 2. Other analytes not listed above must have a minimum response factor of 0.01 3. \* Dissociated to Azobenzene



**LABORATORIES, INC.**  
1835 W. 205th Street  
Torrance, CA 90501  
Tel: (310) 618-8889

Page 1 of 1

ADDENDUM TO

|                  |                            |
|------------------|----------------------------|
| Document         | ALL ANALYTICAL SOPS        |
| Revision Number  | CURRENT REVISIONS          |
| Section          | 10.2 Instrument Parameters |
| Date             | 11 September 2019          |
| Reference Number | AA.7                       |

This applies to all GC/MS, GC, HPLC-MS, HPLC, ICP-MS, ICP and IC Method SOPs

Section 10.2 shall include:

**10.2. Instrument Parameters**

- 10.2.1. Instrument parameters setup stipulated in the SOPs, are instrument suggested parameters. Fine tune the instrument to obtain optimum instrument condition.
- 10.2.2. Print and staple a copy of the current instrument parameter on the instrument log for easy access when performing daily instrument routine check.
- 10.2.3. In the event that instrument parameters necessitate a change, replace the instrument parameter printout with the new parameter setup. Archive the previous instrument parameters at the back of the instrument maintenance log.

PREPARED BY:  Date: 9/11/19  
Name Farina Madamba  
Title QA / QC Coordinator

APPROVED BY:  Date: 09.11.19  
Name Kenette Pimentel  
Title QA Manager

APPROVED BY:  Date: 09-11-19  
Name Caspar Pang  
Title Laboratory Director

## STANDARD OPERATING PROCEDURES

SEMIVOLATILE ORGANICS BY GC/MS

SOP No.: EMAX-8270 Revision No. 6 Date: 10-Jul-14

Prepared By: Souzan Grease *Souzan Grease* Date: 07-09-14

Approved By: Kenette Pimentel *K. Pimentel* Date: 07-09-14  
QA Manager

Approved By: Caspar Pang *C. Pang* Date: 07-09-14  
Laboratory Director

Control Number: 8270-06-

**1.0 SCOPE AND APPLICATION**

- 1.1. This method is used to determine the concentration of semivolatife organic compounds extracted from many types of solid waste matrices, soils, air sampling media and water samples. Analytes that are listed in Table 9 were determined when this SOP was established. Additional analytes may be added upon completion of similar validation as the analytes that are listed in Table 8 & 9.
- 1.2. This SOP is an adaptation of method SW846 8270C.

**2.0 SUMMARY OF METHOD**

- 2.1. Samples are extracted with methylene chloride. Extracts are concentrated and appropriate cleanup procedure is applied if necessary.
- 2.2. Internal standards are added to an aliquot of the final extract and are qualitatively and quantitatively analyzed by gas chromatography equipped with mass spectrometry (GC/MS).
- 2.3. **Interference**
  - 2.3.1. Solvents, reagents, glassware, and other sample processing devices are all possible sources of artifacts and/or interferences to sample analysis. Hence, quality control of chemicals and proper decontamination of re-usable glassware and proofing the analytical instrument to be free from contamination shall be observed.
  - 2.3.2. Raw GC/MS data from all blanks, samples, and spikes must be evaluated for interference. Determine source of interference in the preparation and/or cleanup of the samples and Perform corrective action to eliminate the problem.
  - 2.3.3. Contamination by carry-over can occur whenever high-concentration and low-concentration samples are sequentially analyzed. To reduce carryover, rinse the sample syringe with solvent between sample injections. Whenever an unusually concentrated sample is encountered, it should be followed by the analysis of solvent to check for cross-contamination.
  - 2.3.4. Another possible source of contamination is the analytical instrument itself. This can be monitored by analyzing an instrument blank prior to any analysis.

**3.0 DETECTION LIMITS**

- 3.1. **Detection Limit (DL), Limit of Detection (LOD) & Limit of Quantitation (LOQ)**
  - 3.1.1. Refer to EMAX-QA04 for generation, validation and verification for DL, LOD and LOQ.



## STANDARD OPERATING PROCEDURES

**SEMIVOLATILE ORGANICS BY GC/MS**

SOP No.: EMAX-8270 Revision No. 6 Date: 10-Jul-14

3.1.2. Refer to Table 8 & 9 for established limits.

**4.0 DYNAMIC RANGE**

- 4.1. The highest quantifiable concentration requiring no dilution is equal to the highest calibration point. All samples analyzed above this concentration are considered "over-range" and requires dilution for proper quantitation.
- 4.2. Likewise, the lowest quantifiable concentration of diluted samples is equal to the lowest calibration point. All diluted samples analyzed below this concentration are considered "under-range". A lower dilution factor is required for proper quantitation.
- 4.3. The dynamic range established for this method are:

| <u>Water (µg/L)</u> | <u>Soil (µg/kg)</u> |
|---------------------|---------------------|
| 10 - 100 µg/L       | 330 - 3300 µg/kg    |

**5.0 SAMPLE HOLDING TIME & PRESERVATION****5.1. Sample Preservation**

- 5.1.1. Store water and soil samples at ≤ 6°C away from light without freezing.
- 5.1.2. Store all extracts at ≤ 6°C without freezing.

**5.2. Holding Time**

- 5.2.1. Extract water samples within 7 days from sampling date.
- 5.2.2. Extract soil samples within 14 days from sampling date.
- 5.2.3. Analyze all extracts within 40 days from extraction completion date.

**6.0 ASSOCIATED SOPs**

- 6.1. EMAX-1311 TCLP for Organic and Inorganic Analytes
- 6.2. EMAX-3520 Extraction, Continuous Liquid/Liquid
- 6.3. EMAX-3540 Extraction, Soxhlet
- 6.4. EMAX-3546 Extraction, Microwave
- 6.5. EMAX-3550 Extraction, Pulse Sonication
- 6.6. EMAX-3580 Waste Dilution
- 6.7. EMAX-3640 Cleanup, GPC
- 6.8. EMAX-DM01 Data Flow and Review
- 6.9. EMAX-QA04 Detection Limit (DL)
- 6.10. EMAX-QA05 Training
- 6.11. EMAX-QA08 Corrective Action

## STANDARD OPERATING PROCEDURES

**SEMIVOLATILE ORGANICS BY GC/MS**SOP No.: EMAX-8270 Revision No. 6 Date: 10-Jul-14

- 
- 
- 6.12. EMAX-QC01 Quality Control for Chemicals
  - 6.13. EMAX-QC02 Analytical Standard Preparation
  - 6.14. EMAX-QC07 Glassware Cleaning
  - 6.15. EMAX-SM01 Sample Management
  - 6.16. EMAX-SM03 Waste Disposal
  - 6.17. EMAX-SM04 Analytical and QC Sample Labeling

**7.0 SAFETY**

- 7.1. Read all SDS for all chemicals listed in this SOP.
- 7.2. Treat all reagents, standards, and samples as potential hazards. Observe the standard laboratory safety procedures. Wear protective gear, i.e., lab coat, safety glasses, gloves, at all times when performing this procedure. Perform all sample and standard handling in the fume hood.
- 7.3. If for any reason, solvent and/or other reagents get in contact with the skin or any other part of the body, rinse the affected body part thoroughly with tap water. If irritations persist, inform your supervisor immediately so that proper action can be taken.

**8.0 INSTRUMENTS, CHEMICALS & REAGENTS****8.1. Instruments and Supplies**

|                        |  |
|------------------------|--|
| Gas Chromatography     | Agilent Technologies 7890A with split/splitless injection, Shimadzu GC-17A, or equivalent  |
| Mass Spectrometer      | Agilent Technologies 5975C MSD or Shimadzu GCMS – GP 5000 capable of scanning from 1.6 to 1050 amu every 1 second using 70 volts electrode energy in the electron impact ionization mode or equivalent |
| GC/MS Interface        | Capillary-direct into the mass spectrometer source or equivalent   |
| Chromatographic Column | ZB-5MS (20 m x 0.18 mm x 0.32 µm) or equivalent  |
| Data System            | MS-ChemStation with Enviroquant software or equivalent   |
| GC Autosampler         | Agilent Technologies 7683B series injector or Shimadzu AOC-20i capable of direct injection of 1 µL and 10 µL of extract.   |
| Gases                  | Ultra high purity helium   |
| Syringes               | 10 µL, 25 µL, 50 µL, 100 µL, 250 µL, 500 µL and 1000 µL syringe Hamilton 202N or equivalent  |
| Vials                  | Autosampler vials with teflon lined septa  |

**8.2. Chemicals and Reagents**

|                                      |
|--------------------------------------|
| Methylene chloride, pesticides grade |
|--------------------------------------|

## STANDARD OPERATING PROCEDURES

**SEMIVOLATILE ORGANICS BY GC/MS**SOP No.: EMAX-8270 Revision No. 6 Date: 10-Jul-14

|                       |
|-----------------------|
| Methanol, high purity |
|-----------------------|

**9.0 STANDARDS****9.1. Standard Preparation**

- 9.1.1. Follow procedures for all standard preparations and labeling as described in EMAX-QC02 and EMAX-SM04, respectively.
- 9.1.2. Other concentration levels may be prepared to meet the data quality objective of a project.

**9.2. Stock Standard**

- 9.2.1. Purchase stock standards as certified solutions from a reputable vendor (refer to Table 1 for the listing of all certified solutions). Standards are expected to be at least 96% purity. Read vendor's note if correction has been applied to certified values, otherwise corrections must be applied.
- 9.2.2. Transfer the stock standard solutions into 2 mL amber vial with Teflon lined screw caps and store at -10°C to -20°C.

**9.3. Intermediate Standard**

- 9.3.1. Using stock standard solutions, prepare the intermediate standard in Methylene Chloride according to Table 1.

**9.4. Internal Standard**

- 9.4.1. The internal standard shall include 1,4-Dichlorobenzene-d<sub>4</sub>, Naphthalene-d<sub>8</sub>, Acenaphthalene-d<sub>10</sub>, Phenanthrene-d<sub>10</sub>, Chrysene-d<sub>12</sub> and Perylene-d<sub>12</sub> in methylene chloride solution.
- 9.4.2. Purchase internal standard solutions as certified solution from a reputable vendor at 4,000 µg/mL.
- 9.4.3. Prepare a 10 mL of 2,000 µg/mL of working internal standard from 4,000 µg/mL (refer to Table 4). Transfer the solution in a properly labeled 10 mL amber vial and store in -10°C to -20°C.

**9.5. GC/MS Tuning**

- 9.5.1. The tuning standard shall include decafluorotriphenylphosphine (DFTPP), 4,4-DDT, Pentachlorophenol, and Benzidine.
- 9.5.2. Purchase tuning standard solution as certified standard at 1000 µg/mL.
- 9.5.3. Prepare a 500 µL of 50 µg/mL of working standard tuning solution (refer to Table 5). Transfer the solution in a 1 mL amber vial and store in -10°C to -20°C.

**9.6. Surrogate Standard**

- 9.6.1. Purchase surrogate stock standards as certified standard.
  - 9.6.1.1. The acid surrogate mixture includes Phenol-d<sub>5</sub>, 2-Fluorophenol, and 2,4,6-Tribromophenol at 150 µg/mL.

## STANDARD OPERATING PROCEDURES

**SEMIVOLATILE ORGANICS BY GC/MS**SOP No.: EMAX-8270 Revision No. 6 Date: 10-Jul-14

9.6.1.2. The basic neutral surrogate mixture includes Nitrobenzene-d<sub>5</sub>, 2-Fluorobiphenyl, Terphenyl-d<sub>14</sub>, and 1,2-Dichlorobenzene-d<sub>4</sub> at 50 µg/mL.

9.6.2. For typical extraction [soil: 30 g – 2 mL or water: 1000 mL – 2 mL], add 0.4 mL of surrogate spiking standard to the sample prior to extraction. Spike volume may be adjusted to normalize with the final extract and yield the same concentration.

**9.7. Calibration Standard**

9.7.1. Prepare working standard solutions for initial calibration and daily calibration (refer to Tables 2A-2C). Transfer the solutions in a 1 mL amber vial and store them at ≤ 6°C without freezing.

**9.8. ICAL Verification Standard (Second Source Verification) (ICV)**

9.8.1. Purchase a certified ICV standard from a different vendor. The ICV standard contains the same list of compounds as the stock standard (refer to Table 1B for the standard mix and the corresponding vendors).

9.8.2. Prepare a 500 µL of 25 µg/mL check standard solution (refer to Table 3A-3C). Transfer the solution in a properly labeled 1 mL amber vial and store at ≤ 6°C without freezing.

**9.9. LCS/MS Spiking Standards**

9.9.1. Purchase spiking standards as certified solutions from a different source.

9.9.2. Refer to specific extraction SOP for spiking amount used for LCS/LCSD/MS/MSD, unless otherwise specified by project.

**10.0 PROCEDURES****10.1. Sample Preparation**

10.1.1. For aqueous samples (including TCLP leachates), refer to EMAX-3520 or EMAX-1311. Record in the extraction log if presence of residual chlorine is observed.

10.1.2. For solid samples, refer to EMAX-3550, EMAX-3540 or EMAX-3546.

10.1.3. For waste samples, refer to EMAX-3580.

10.1.4. After extraction, examine the color and consistency of the extract. If the extract appears to be opaque and/or viscous, it is advisable to perform extract cleanup preferably GPC. Refer to EMAX-3640.

**10.2. Instrument Parameters**

10.2.1. Set the instrument parameters as suggested in Table 6. Fine tune the instrument to obtain optimum instrument condition.

10.2.2. Print and display current condition on the instrument for easy access when performing daily instrument routine check.

10.2.3. In the event that instrument parameters necessitate a change, replace the instrument parameter printout with the new parameter setup. Archive the previous instrument parameters in the instrument maintenance log.

10.2.4. Set injection volume to 1 µL to 2 µL.

## STANDARD OPERATING PROCEDURES

**SEMIVOLATILE ORGANICS BY GC/MS**SOP No.: EMAX-8270 Revision No. 6 Date: 10-Jul-14**10.3. Calibration**

10.3.1. Set GC/MS operating condition as described in Section 10.2.

10.3.2. Perform Tune Check

10.3.2.1. Analyze a solution containing 50 µg/mL of tuning standard working solution, DFTTP, DDT, benzidine and pentachlorophenol.

10.3.2.2. A valid Tune Check expires after 12 hours. Evaluate the tune check by averaging three scans (the peak apex scan and the scan immediately preceding and the scan immediately following the apex). Apply a background subtraction using a single scan no more than 20 scans prior to the elution of DFTPP. Do not subtract part of the DFTPP peak or any other discrete peak that does not coelute with DFTPP. Use the DFTPP mass intensity criteria in the manufacturer's instructions as primary tuning acceptance criteria, otherwise refer to Table 7 for acceptance criteria. A valid tune expires after 12 hours.

10.3.2.3. Evaluate column performance and injection port inertness using the data acquisition software.

- Degradation of DDT to DDE and DDD must be less than 20% based on area obtained from the total ion chromatogram.
- Benzidine and Pentachlorophenol must be present at their normal responses. Evaluate the tailing factor of benzidine and pentachlorophenol. Benzidine tailing  $\leq 3$  and pentachlorophenol  $\leq 5$ . Refer to the attached figure for peak evaluation.

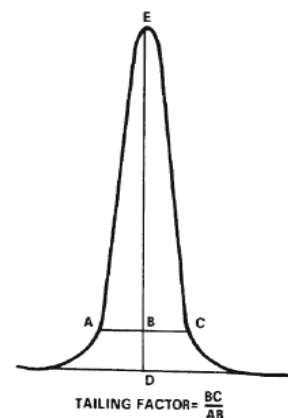

Example calculation: Peak Height = DE = 100 mm  
 10% Peak Height = BD = 10 mm  
 Peak Width at 10% Peak Height = AC = 23 mm  
 AB = 11 mm  
 BC = 12 mm  
 Therefore: Tailing Factor =  $\frac{12}{11} \approx 1.1$

10.3.2.4. If tune check is non-compliant, refer to Section 12 for corrective action.

10.3.3. Initial Calibration (ICAL)

10.3.3.1. Perform ICAL when one of the conditions occurs.

- Instrument is new
- Instrument undergoes a major repair
- DCC failed to meet the acceptance criteria

10.3.3.2. Optimize the instrument condition prior to ICAL.

- Ensure that instrument parameters are set up properly
- Ensure that there is no evidence of leak
- Ensure that instrument maintenance is performed on schedule

## STANDARD OPERATING PROCEDURES

**SEMIVOLATILE ORGANICS BY GC/MS**SOP No.: EMAX-8270 Revision No. 6 Date: 10-Jul-14

- 
- 
- Ensure that instrument tune check and column performance is not indicative that it is at the threshold of failing the acceptance criteria.
- 10.3.3.3. Analyze a multi-point initial calibration curve as suggested in Figure 3 after a valid tune check.
- 10.3.3.4. Base quantitation of identified compounds on the integrated abundance from the EICP of the assigned primary characteristic ion (refer to Tables 8 & 9). For optimum output, assign internal standard to each compound based on the nearest retention time or as suggested on tables 8 and 9.
- 10.3.3.5. **Evaluate the ICAL Acceptance**
- 10.3.3.5.1. Check for completeness of target compound list. If there is/are missing compound(s), perform the following:
- Check the established retention time window
  - Check the relative intensity of major ions
  - Adjust accordingly if necessary.
- 10.3.3.5.2. Evaluate retention time of each analyte with respect to the nearest internal standard. The relative retention time (RRT) of each analyte should agree within  $\pm 0.06$  RRT units.
- 10.3.3.5.3. At a minimum, evaluate System Performance Check Compounds (SPCCs) and Calibration Check Compounds (CCCs) as specified in Appendix 1. The list of SPCCs and CCCs are provided in Tables 10 and 11.
- 10.3.3.5.4. Check RSD and Correlation Coefficient. If more than 10% of the compounds included with the initial calibration exceed the 15% RSD limit and do not meet the minimum correlation coefficient (0.99) for alternate curve fits, then the chromatographic system is considered too reactive for analysis to begin. Perform necessary instrument maintenance and repeat calibration. Refer to 10.3.3.2., Section 12 for corrective action.
- 10.3.3.6. **Application of ICAL Curve for Quantitation**
- 10.3.3.6.1. Generate a summary of Relative Response Factors for each analyte at each concentration. Calculate the Average Relative Response Factor (RRFm), the Standard Deviation (SD), and the Relative Standard Deviation (RSD) according to Eq.-10.5.1.1, Eq.-10.5.1.2, Eq.-10.5.1.6 and Eq.-10.5.1.7 respectively.
- 10.3.3.6.2. If RSD is  $\leq 15\%$  average response factor may be applied.
- 10.3.3.6.3. Apply Inverse Weighting Factor ( $1/y$  or  $1/y^2$ ;  $y$  being the instrument response) if it is determined to be the best fit for specific analytes. This approach may be applied to any analyte including analyte that has RSD of  $\leq 15\%$  and correlation coefficient of  $\geq 0.995$ .
- 10.3.3.6.4. Apply linear least squares regression if past experience or priori knowledge of instrument response is known to be the best fit for specific analytes. This approach may be applied to any analyte including analyte that has RSD of  $\leq 15\%$  and correlation of determination (COD)  $\geq 0.99$ .

## STANDARD OPERATING PROCEDURES

**SEMIVOLATILE ORGANICS BY GC/MS**SOP No.: EMAX-8270 Revision No. 6 Date: 10-Jul-14

10.3.3.6.5. It may be appropriate to force the regression through zero for specific analytes.<sup>1</sup> When exercising this option [as included in the data acquisition software], make sure that the origin (0,0) is not included as a calibration point but rather the intercept is set to zero. This option shall only be applied if the curve favors better accuracy of quantitation.

10.3.3.7. Submit summary of ICAL, raw data and manual integration (if any) for secondary review.

10.3.4. Initial Calibration Verification (ICV)

10.3.4.1. Analyze ICV to verify the concentration of the ICAL standards (Refer to Section 9.8).

10.3.4.2. Check for completeness of analytes as described in Section 10.4.3.

10.3.4.3. Compare the retention times of the internal standards to the ICAL mid-point. Excursion of  $\pm 30$  seconds indicate instrument malfunction. Corrective action is required prior to further analysis.

10.3.4.4. Compare the area of the Internal Standards (IS) acquired against the midpoint of the initial calibration point. The extracted ion current profile (EICP) must be within a factor of two (- 50% to + 100%).

10.3.4.5. Refer to Appendix 1 for ICV acceptance criteria and/or corrective action.

10.3.4.6. When non-compliant refer to Section 12 for corrective action.

10.3.5. Daily Continuing Calibration (DCC)

10.3.5.1. Analyze DCC to check the validity of the ICAL (refer to 9.7).

10.3.5.2. Check for completeness of analytes as described in Section 10.4.3.

10.3.5.3. Evaluate System Performance Check Compounds (SPCC) and Calibration Check Compounds (CCC) as specified in Appendix 1.

10.3.5.4. Compare the retention times of the internal standards to the ICAL mid-point. Excursion of  $\pm 30$  seconds indicates instrument malfunction. When non-compliant check the column head pressure, gas supply or leaks. Corrective action is required prior to further analysis.

10.3.5.5. Compare the area of the Internal Standards (IS) acquired against the midpoint of the initial calibration point. The extracted ion current profile (EICP) must be within a factor of two (-50% to +100%).

10.3.5.6. Establish RRF of each analyte, calculate %D (Eq.-10.5.2.1) against the ICAL.

10.3.5.7. Refer to Appendix 1 for DCC acceptance criteria and/or corrective action,

10.3.5.8. When non-compliant refer to Section 12 for corrective action.

10.4. **Analysis**

10.4.1. Extract Preparation

10.4.1.1. Allow extracts to equilibrate with room temperature.

<sup>1</sup> SW846 Method 8000B, Section 7.5.3

## STANDARD OPERATING PROCEDURES

**SEMIVOLATILE ORGANICS BY GC/MS**SOP No.: EMAX-8270 Revision No. 6 Date: 10-Jul-14

10.4.1.2. Measure 300 µL of extract, transfer into an autosampler vial.

10.4.1.3. Add 6 µL of 2000 µg/mL of internal standard (refer to 9.4).

10.4.1.4. Seal the vial with Teflon-lined septa cap.

10.4.2. Analytical Sequence

10.4.2.1. Analyze instrument blank.

10.4.2.2. Analyze DFTPP and evaluate tuning.

10.4.2.3. Analyze DCC and check ICAL validity.

10.4.2.4. Analyze Method Blank.

10.4.2.5. Analyze Lab Control Sample and Lab Control Sample Duplicate (if requested).

10.4.2.6. Analyze samples to a maximum number of 12-hours from time of DFTPP injection.

10.4.2.7. Analyze a pair of matrix spikes (MS/MSD) for every 20 samples of the same matrix.

10.4.2.8. Record analytical sequence in the analysis log.

10.4.3. Sample Result Evaluation

10.4.3.1. Check the QC criteria as soon as the data is available.

- ✓ Check method blank. If result is non-compliant and analyte in question is not detected in any sample or contamination is < 10X of the sample concentration, results maybe reportable. Verify with the PM if results can be reported.
- ✓ Compare the retention times of each Internal Standards (IS) to the ICAL mid point (must be ± 30 seconds).
- ✓ Compare the area of each IS acquired against the mid point of the ICAL. The Extracted ION Current Profile (EICP) must be within a factor of two (-50 to +100%).
- ✓ Check concentration of target analytes if calibration range is exceeded.
- ✓ Check surrogate recoveries against project specific requirements (PSR). In the absence of PSR, default to Appendix 1 QC limits.
- ✓ If any of the above checkpoints indicate a problem, re-analysis is required. Note observations on the analysis log. When result arise to questionable result, e.g. inconsistency from the first analysis, consult the Supervisor for further action.

10.4.3.2. **Qualitative Identification**

- The intensities of the characteristic ions must maximize in the same scan or within one scan of each other.
- The relative retention time (RRT) of the sample component is within 0.06 RRT units of the RRT of the standard component.
- The relative intensity of the characteristic ions agrees within 30% of the relative intensity of these ions in the reference spectrum.



## STANDARD OPERATING PROCEDURES

**SEMIVOLATILE ORGANICS BY GC/MS**SOP No.: EMAX-8270 Revision No. 6 Date: 10-Jul-14

- Check the chromatogram for possible misidentified analytes. Investigate visible peaks in the chromatogram that were not identified in the data output. Manually integrate the peak if necessary. For manual integration refer to EMAX-DM01.
- Structural isomers that produce very similar mass spectra should be identified as individual isomers if they have sufficiently different GC retention times. Sufficient GC resolution is achieved if the height of the valley between two isomers peaks is less than 25% of the sum of the two peak heights. Otherwise, structural isomers are identified as isomeric pairs.<sup>2</sup>

10.4.3.2.1. For samples containing components not associated with the calibration standards, perform a library search for purposes of tentative<sup>3</sup> (TIC). Execute LSC (Chem Station program) to initiate the library search using NIST/EPA/MSDC mass spectral library. Visually inspect each extracted mass ion chromatograph to determine the identification of the unknown before final reporting following the guidelines below.

- Relative intensities of major ions in the reference spectrum (ions greater than 10% of the most abundant ion) should be present in the sample spectrum.
- The relative intensities of the major ions should agree within + 20%.

Example: for an ion with an abundance of 50% of the standard spectra, the corresponding sample ion abundance must be between 30 and 70%.

- Molecular ions present in reference spectrum but not present in the sample spectrum.
- Ions present in the sample spectrum but not in the reference spectrum should be reviewed for possible background contamination or presence of co-eluting analytes.
- Ions present in the reference spectrum but not present in the sample spectrum should be reviewed for possible subtraction from the sample spectrum because of the background contamination or co-eluting analytes. Data system library reduction programs can sometimes create these discrepancies.

10.4.3.2.2. **Reporting TICs**

- If the library search produces a match at or above 85%, report the analyte.
- If the library search produces more than one analyte at or above 85%, report the first analyte (highest).

<sup>2</sup> SW846 Method 8270C, Section 7.6.1.4

<sup>3</sup> Library search is performed only when indicated in the PSR.

## STANDARD OPERATING PROCEDURES

**SEMIVOLATILE ORGANICS BY GC/MS**SOP No.: EMAX-8270 Revision No. 6 Date: 10-Jul-14

- If the library search produces no matches at or above 85%, the compound should be reported as unknown.

**10.4.3.3. Quantitation**

- 10.4.3.3.1. Apply the appropriate quantitation method (Section 10.3.3.6). Calculate the concentration of any positively identified target analyte using Eq.-10.5.3. Apply the dilution factor for diluted samples to calculate for the final concentration of the sample.

**10.4.3.4. Manual Integration**

- 10.4.3.4.1. Refer to EMAX-DM01, manual integration section.

**10.4.3.5. Dealing with Carryover**

- 10.4.3.5.1. Check the sample analyzed after a sample having target analyte concentrations exceeding the calibration range.
- 10.4.3.5.2. If there was no target analyte detected as found in the sample that exceeded the calibration range, proceed with data reduction.
- 10.4.3.5.3. If there is any target analyte detected as found in the sample that exceeded the calibration range, re-analyze the sample to rule out carry over. If carry over is confirmed, proceed with data reduction and report the data from re-analysis.
- 10.4.3.5.4. To clean-up the system, run a blank sample. If improved result is noted repeat this process until no evidence of contamination is observed. Otherwise inform the Supervisor for further instruction.

**10.5. Calculations****10.5.1. Initial Calibration****10.5.1.1. Calculate for Relative Response Factor (RRF)**

$$RRF = \frac{(AX)(CIS)}{(AIS)(CX)} \quad \text{Eq.-10.5.1.1}$$

where:

- AX - Area of characteristic ion for the compound being measured
- AIS - Area of characteristic ion for the specific internal standard
- CX - Concentration of the compound being measured
- CIS - Concentration of the specific internal standard

**10.5.1.2. Calculate for Average Relative Response Factor (RRF<sub>m</sub>)**

$$RRF_m = \frac{\sum RRF}{n} \quad \text{Eq-10.5.1.2}$$

where:

- RRF<sub>m</sub> - average response factor

## STANDARD OPERATING PROCEDURES

**SEMIVOLATILE ORGANICS BY GC/MS**SOP No.: EMAX-8270Revision No. 6Date: 10-Jul-14 $\sum RRF$  - summation of response factors $n$  - number of measurements**10.5.1.3. Calculate for Least Square Linear Regression**

$$y = ax + b \quad \text{Eq.-10.5.1.3}$$

where:

 $y$  - Response Ratio (AX/AIS) $x$  - Amount Ratio (CX/CIS) $a$  - x1 = slope of the line

$$a = \frac{\sum (x - \bar{x})(y - \bar{y})}{\sum (x - \bar{x})^2}$$

where:

 $\bar{x}$  - Average of amount ratios $\bar{y}$  - Average of response ratios $b$  - x0 = intercept of the line

$$b = \bar{y} - a * \bar{x}$$

**10.5.1.4. Calculate for Inverse Weighting Factor**

$$y = ax + b \quad \text{Eq.-10.5.1.4}$$

where:

 $y$  - Response Ratio (AX/AIS) $x$  - Amount Ratio (CX/CIS) $a$  - x1 = slope of the line

$$a = \frac{\sum [(x - x_a)(y - y_a)]}{\sum (x - x_a)^2}$$

where:

$$x_a = \sum [x(1/x)] / \sum (1/x)$$

$$y_a = \sum [y(1/x)] / \sum (1/x) \text{ or}$$

$$x_a = \sum [x(1/x^2)] / \sum (1/x^2)$$

## STANDARD OPERATING PROCEDURES

**SEMIVOLATILE ORGANICS BY GC/MS**SOP No.: EMAX-8270 Revision No. 6 Date: 10-Jul-14

$$y_a = \frac{\sum[y(1/x^2)]}{\sum(1/x^2)}$$

b = x0 = intercept of the line

$$b = y_a - a * x_a$$

10.5.1.5. **Calculate Inverse Quadratic**

$$y = ax^2 + bx + c \quad \text{Eq.-10.5.1.5}$$

where:

y - Resp\_Ratio = **x0 + x1 \* Amt\_Ratio + x2 \* (Amt\_Ratio)<sup>2</sup>**

x - Amt\_Ratio

c - **x0 = Det 0/Det b**

b - **x1 = Det 1/Det b**

a - **x2 = Det 2/Det b**

$$W_i = \frac{\frac{1}{X_i}}{\sum_{i=1}^n \frac{1}{X_i}}$$

where:

X<sub>i</sub> - amount ratio = Conc of Std/Conc of IS

Y<sub>i</sub> - response ratio = Resp of Std/Resp of IS

**Wi** - 1/X)/SUM(1/X)

**<X>** - SUM(W<sub>i</sub>\*X<sub>i</sub>)

**<Y>** - SUM(W<sub>i</sub>\*Y<sub>i</sub>)

**<XX>** - SUM(W<sub>i</sub>\*(X<sub>i</sub>)<sup>2</sup>)

**<XXX>** - SUM(W<sub>i</sub>\*(X<sub>i</sub>)<sup>3</sup>)

**<XXXX>** - SUM(W<sub>i</sub>\*(X<sub>i</sub>)<sup>4</sup>)

**<YY>** - SUM(W<sub>i</sub>\*(Y<sub>i</sub>)<sup>2</sup>)

**<XY>** - SUM(W<sub>i</sub>\*X<sub>i</sub>\*Y<sub>i</sub>)

**<XXY>** - SUM(W<sub>i</sub>\*(X<sub>i</sub>)<sup>2</sup>\*Y<sub>i</sub>)

**<Yd2>** - SUM((Y<sub>i</sub>-<Y>)<sup>2</sup>\*W<sub>i</sub>)

**Ye** - x0+x1\*X<sub>i</sub>+x2\*X<sub>i</sub><sup>2</sup>-<Y>

**<Ye2>** - SUM(Ye<sup>2</sup>\*W<sub>i</sub>)

## STANDARD OPERATING PROCEDURES

**SEMIVOLATILE ORGANICS BY GC/MS**SOP No.: EMAX-8270 Revision No. 6 Date: 10-Jul-14

|       |      |       |        |
|-------|------|-------|--------|
| Det b | 1    | <X>   | <XX>   |
|       | <X>  | <XX>  | <XXX>  |
|       | <XX> | <XXX> | <XXXX> |

|       |     |      |       |
|-------|-----|------|-------|
| Det 0 | 1   | <X>  | <XX>  |
|       | <X> | <XX> | <XXX> |
|       | <Y> | <XY> | <XXY> |

|       |      |       |        |
|-------|------|-------|--------|
| Det 1 | 1    | <X>   | <XX>   |
|       | <Y>  | <XY>  | <XXY>  |
|       | <XX> | <XXX> | <XXXX> |

|       |      |       |        |
|-------|------|-------|--------|
| Det 2 | <Y>  | <XY>  | <XXY>  |
|       | <X>  | <XX>  | <XXX>  |
|       | <XX> | <XXX> | <XXXX> |

$$r^2 = \frac{Y_e^2}{Y_d^2}$$

$$ccf^2 = (r^2)^{1/2}$$

## 10.5.1.6. Calculate for Standard Deviation (SD)

$$SD = \sqrt{\frac{\sum_{i=1}^n (x_i - \bar{x})^2}{n - 1}} \quad \text{Eq.-10.5.1.6}$$

where:

 $X_i$  - result at  $i^{\text{th}}$  measurement $\bar{x}$  - mean $n$  - number of measurements

## 10.5.1.7. Calculate for % relative standard deviation (%RSD)

$$\%RSD = \frac{SD}{RRF_m} * 100\% \quad \text{Eq.-10.5.1.7}$$

where:

 $SD$  - standard deviation $RRF_m$  - average response factor

## STANDARD OPERATING PROCEDURES

**SEMIVOLATILE ORGANICS BY GC/MS**SOP No.: EMAX-8270 Revision No. 6 Date: 10-Jul-1410.5.1.8. **Calculate the Relative Retention Time (RRT)**

$$RRT = \frac{\text{Retention Time of the Analyte}}{\text{Retention Time of the Internal Standard}} \quad \text{Eq.-10.5.1.8}$$

10.5.2. **Calibration Check/Continuing Calibration**10.5.2.1. **Calculate Percent Difference (%D) when RRF<sub>m</sub> is used for quantitation**

$$\%D = \frac{[RRF_c - RRF_m]}{RRF_m} * 100\% \quad \text{Eq.-10.5.2.1}$$

where:

RRF<sub>c</sub> - response factor from continuing calibration standardRRF<sub>m</sub> - average response factor10.5.2.2. **Calculate Percent Deviation (%D<sub>t</sub>) when applied calculation is other than ARF**

$$\%D_t = \frac{|T_t - T_f|}{T_t} * 100\% \quad \text{Eq.-10.5.2.2}$$

where:

T<sub>t</sub> - true value of standard in µg/LT<sub>f</sub> - found value of standard in µg/L

10.5.3. Calculation of Sample Concentration (Water and Soil/Sediment Samples). When a compound is identified, the quantitation of that compound shall be based on the integrated abundance from the EICP of the primary characteristic ion.

10.5.3.1. **Water Samples**

$$\text{Concentration (ug/L)} = \frac{(A_x)(I_s)(V_e)(DF)}{(A_{is})(RRF_m)(V_i)(V_t)} \quad \text{Eq.-10.5.3.1}$$

where:

A<sub>x</sub> - area of characteristic ion for the compound to be measuredI<sub>s</sub> - amount of internal standard addedV<sub>e</sub> - extract final volume from sample extraction, usually 1 mLDF - dilution factor =  $\frac{\text{aliquot}(\mu\text{L}) + \text{solvent}(\mu\text{L})}{\text{aliquot}(\mu\text{L})}$ A<sub>is</sub> - area of characteristic ion for the internal standardRRF<sub>m</sub> - average response factorV<sub>i</sub> - volume of extract injected in µL, usually 1 µLV<sub>t</sub> - volume of water extracted in mL, usually 1000 mL

## STANDARD OPERATING PROCEDURES

**SEMIVOLATILE ORGANICS BY GC/MS**SOP No.: EMAX-8270 Revision No. 6 Date: 10-Jul-1410.5.3.2. **Soil/Sediment Samples (Dry weight basis)**

$$\text{Concentration}(\mu\text{g} / \text{Kg}) = \frac{(A_x)(I_s)(V_e)(DF)}{(A_{is})(RRF_m)(V_i)(W_s)(DW)} \quad \text{Eq.-10.5.3.2}$$

where:

- $A_x$  - area of characteristic ion for the compound to be measured  
 $I_s$  - amount of internal standard injected in ng  
 $V_e$  - volume of extract in mL, usually 1 mL<sup>4</sup>  
 $DF$  - dilution factor =  $\frac{\text{aliquot}(\mu\text{L}) + \text{solvent}(\mu\text{L})}{\text{aliquot}(\mu\text{L})}$   
 $A_{is}$  - area of characteristic ion for the internal standard  
 $RRF_m$  - average response factor  
 $V_i$  - volume of extract injected in  $\mu\text{L}$ , usually 1  $\mu\text{L}$   
 $W_s$  - wet soil weight in kg  
 $DW$  - % solid =  $\frac{100 - \% \text{moisture}}{100}$

10.5.3.3. **Calculation for results subjected to cleanup shall have the following equations:**

$$\text{Concentration}(\mu\text{g} / \text{Kg}) = \frac{(A_x)(I_s)(V_e)(DF)}{(A_{is})(RRF_m)(V_i)(W_s)(DW)} \cdot \frac{V_{bg}}{V_{ig}} \quad \text{Eq.-10.5.3.3.1}$$

$$\text{Concentration}(\mu\text{g} / \text{L}) = \frac{(A_x)(I_s)(V_e)(DF)}{(A_{is})(RRF_m)(V_i)(V_t)} \cdot \frac{V_{bg}}{V_{ig}} \quad \text{Eq.-10.5.3.3.2}$$

where:

- $A_x$  - area of characteristic ion for the compound to be measured  
 $I_s$  - amount of internal standard injection in ng  
 $V_e$  - volume of extract in mL  
 $DF$  - dilution factor =  $\frac{\text{aliquot}(\mu\text{L}) + \text{solvent}(\mu\text{L})}{\text{aliquot}(\mu\text{L})}$   
 $A_{is}$  - area of characteristic ion for the compound to be measured  
 $RRF_m$  - average response factor  
 $V_i$  - volume of extract injected in  $\mu\text{L}$ , usually 1  $\mu\text{L}$   
 $W_s$  - wet soil weight in Kg

<sup>4</sup> For extracts subjected to GPC  $V_i=0.5\text{-mL}$

## STANDARD OPERATING PROCEDURES

**SEMIVOLATILE ORGANICS BY GC/MS**SOP No.: EMAX-8270 Revision No. 6 Date: 10-Jul-14

$$DW - \%solid = \frac{100 - \%moisture}{100}$$

$V_t$  - volume of water extracted in mL

$V_{bg}$  - total volume of extract before GPC clean-up in mL

$V_{ig}$  - injected volume of extracts to GPC in mL

10.5.4. Base all sample result calculations on the ICAL curve, e.g., area ratio of  $A_x/A_{is}$  versus concentration using inverse weighting factor fitted to the initial calibration is also used for determination of sample concentration.

10.5.5. Concentration of TIC is estimated by the same method as target compounds with the following assumptions:

10.5.5.1. The area "Ax" and "Ais" are derived from total ion chromatogram. "Ais" refers to the closest internal standard (IS) free of interference.

10.5.5.2. RRF of the TIC is 1.

10.5.6. Accuracy and Precision

10.5.6.1. **Percent Recovery**

$$\% Recovery = \frac{(C_f - C)}{C_s} \times 100 \quad \text{Eq.-10.5.6.1}$$

where:

$C_f$  - concentration found

$C$  - concentration of sample (use 0 for LCS)

$C_s$  - concentration of spike

10.5.6.2. **Relative Percent Difference (%RPD)**

$$\%RPD = \frac{|C_1 - C_2|}{\left(\frac{C_1 + C_2}{2}\right)} \times 100 \quad \text{Eq.-10.5.6.2}$$

where:

$C_1$  - Measured concentration of the first sample aliquot

$C_2$  - Measured concentration of the second sample aliquot

10.5.7. DDT Degradation

$$\%B = \frac{A_{DDD} + A_{DDE}}{A_{DDT} + A_{DDD} + A_{DDE}} (100) \quad \text{Eq.-10.5.7}$$

where:

$\%B$  - percent breakdown



## STANDARD OPERATING PROCEDURES

**SEMIVOLATILE ORGANICS BY GC/MS**SOP No.: EMAX-8270 Revision No. 6 Date: 10-Jul-14

---

---

*ADDD* - area of DDD*ADDE* - area of DDE*ADDT* - area of DDT**10.6. Data Reduction**

- 10.6.1. Make a copy of the analytical run log and sample preparation log.
- 10.6.2. Highlight the data to be reported.
- 10.6.3. Print a copy of the raw data and the QC report.
- 10.6.4. Check that all positively identified analytes are within the calibration range.
- 10.6.5. Collate the reportable data separating the QC results from the sample results.
- 10.6.6. Keep all other data generated with the analytical folder marked with "For record only".

**10.7. Report Generation**

- 10.7.1. Generate the method.txt file using WDB1C.exe
- 10.7.2. Generate the sample results using F1NV3C.exe or F1N3C4.exe
- 10.7.3. Generate the QC summary using QCV3CN.exe or QCV3CN4.exe
- 10.7.4. Generate the Instrument Performance Check (ICAL and DCC) using F5SVTEST.exe.
- 10.7.5. Generate the IS and RT Summary using F8SV.exe.
- 10.7.6. Generate Lab Chronicle using LABCHRN1.exe
- 10.7.7. Generate the Case Narrative using CN1.exe
- 10.7.8. Arrange the analysis package in sequence as detailed below using section separators. Attach all raw data to every form generated, to include manual integration(s) and re-analyses.
  - 10.7.8.1. Case Narrative
  - 10.7.8.2. Lab Chronicle
  - 10.7.8.3. Sample Results
  - 10.7.8.4. Method Blank Results
  - 10.7.8.5. LCS/LCSD Summary
  - 10.7.8.6. MS/MSD Summary
  - 10.7.8.7. Instrument Performance Check (ICAL)
  - 10.7.8.8. ICAL Summary
  - 10.7.8.9. ICV Summary
  - 10.7.8.10. Instrument Performance Check (DCC)
  - 10.7.8.11. IS and RT Summary
  - 10.7.8.12. DCC Summary

## STANDARD OPERATING PROCEDURES

**SEMIVOLATILE ORGANICS BY GC/MS**SOP No.: EMAX-8270 Revision No. 6 Date: 10-Jul-14

10.7.8.13. Analytical Run Log

10.7.8.14. Sample Preparation Log

10.7.8.15. Non-Conformance Report (if any)

**10.8. Data Review**

10.8.1. Perform a 100% data review in accordance to EMAX-DM01 and the PSR.

10.8.1.1. If any of the checkpoints below indicates a problem, re-analysis is required.

- ✓ Check internal standard area. They should be within -50 to +100% of the ICAL midpoint to be acceptable, otherwise follow PSR.
- ✓ Check retention time of each IS to the ICAL midpoint. They should be within  $\pm$  30 seconds to be acceptable, otherwise follow PSR.
- ✓ Check surrogate recoveries against Project Specific requirements (PSR). In the absence of PSR, default to in-house QC limits.
- ✓ Check concentrations of target analytes if calibration range is exceeded.

10.8.1.2. Review the attached log that they are properly filled.

10.8.1.3. Check the generated reports against the raw data. Check that the analytical data generated indicating positive results are qualitatively and quantitatively correct.

10.8.1.4. Review the case narrative and check that it accurately describes what transpired in the analytical process. Edit as necessary to reflect essential issues not captured by the case narrative generator program.

10.8.2. Submit the analytical folder for secondary review.

**10.9. Preventive Maintenance**

10.9.1. Perform instrument routine preventive maintenance and record on instrument-specific maintenance logs. Routine maintenance ensures that all equipment is operating under optimum conditions, thus reducing the possibility of instrument malfunction that may affect data quality.

10.9.2. Instruments should receive routine preventive maintenance and recorded in instrument-specific maintenance logs. Routine maintenance ensures that all equipment is operating under optimum conditions, thus reducing the possibility of instrument malfunction and consequently affecting data quality. The table below is a list of preventive maintenance activities that are essential to consider in performing this SOP.

| Maintenance Activity       | Description   | Frequency               |
|----------------------------|---|-------------------------|
| Autosampler                | Inspect and clean syringe. Check autosampler response.  | Daily prior to analysis |
| Vacuum System Verification | Verify pressure. Perform system tune check  | Daily prior to analysis |
| Verification               | Check instrument parameters to ensure normal operating conditions. Check instrument performance | Daily prior to analysis |

## STANDARD OPERATING PROCEDURES

**SEMIVOLATILE ORGANICS BY GC/MS**SOP No.: EMAX-8270 Revision No. 6 Date: 10-Jul-14

|                           |  |  |
|---------------------------|--|--|
|                           | (e.g., Daily calibration check, instrument blank, DDT/Endrin breakdown). |  |
| Source Cleaning           | Remove and clean the Mass Spec ion source                                | Every 6 months or as necessary                                   |
| Vacuum System Maintenance | Inspect vacuum pumps, and replace mechanical/diffusion pump oil          | Every 6 months   |
| Documentation             | Record maintenance in instrument service logs                            | Daily prior to analysis to include services done by third party. |

**11.0 QUALITY CONTROL****11.1. Analytical Batch QC**

- 11.1.1. Perform tune check to verify that the mass spectrometer meets standard mass spectra abundance criteria prior to calibration and check for any contamination.
- 11.1.2. Perform Initial Calibration (ICAL) to establish a calibration curve for the quantification of the analytes of interest. Obtain secondary review before using the new ICAL.
- 11.1.3. Establish Retention Time Window position for each analyte every after ICAL for proper qualitative identification.
- 11.1.4. Perform Initial Calibration Verification (ICV) every after ICAL to verify accuracy of ICAL.
- 11.1.5. Perform Continuing Calibration Verification (CCV) every 12 hours to verify that the instrument response is reliable, and has not changed significantly from the current ICAL curve.
- 11.1.6. Evaluate Relative Retention Time for each analytes in every sample to be within  $\pm 0.06$  RRT units.
- 11.1.7. Verify Internal Standards (IS) for quantitatively accuracy and that its Retention Time is within  $\pm 30$  seconds from retention time of the midpoint standard in the ICAL and EICP area is within -50 to +100% of ICAL midpoint standard.
- 11.1.8. Evaluate Surrogate recovery to monitor instrument response on every sample.

**11.2. Sample Preparation Batch QC**

- 11.2.1. Analyze Method Blank (MB) to demonstrate that preparation of sample was free from contamination.
- 11.2.2. Analyze Lab Control Sample (LCS) to assess preparative batch accuracy and precision.
- 11.2.3. Analyze Matrix Spike (MS/MSD) to assess matrix interference.
- 11.2.4. Properly treat lab wares used in the sample preparation as specified in EMAX-QC07.
- 11.2.5. Solvents and reagents must undergo quality control check in the stationary laboratory prior to its use. Refer to EMAX-QC01 for details.
  - Verify that the spike amount added is accurate by checking the record.

## STANDARD OPERATING PROCEDURES

**SEMIVOLATILE ORGANICS BY GC/MS**

SOP No.: EMAX-8270 Revision No. 6 Date: 10-Jul-14

---

---

- If LCS is within acceptance criteria and the right amount of spike is added into the sample then it is indicative of matrix interference. Discuss the probable matrix interference in the case narrative.

**11.3. Method QC**

- 11.3.1. All analytes reported must have a valid DL, LOD and LOQ as described in EMAX-QA04.
- 11.3.2. All analysts conducting this analysis must demonstrate capability (IDOC/DOC) as described in EMAX-QA05.
- 11.4. Refer to Appendix 1 for all related Quality Control parameters, frequency and acceptance criteria.

**12.0 CORRECTIVE ACTIONS**

12.1. Corrective action for each Quality Control Procedures is summarized in Appendix 1.

**12.2. Sample Preparation QC**

- 12.2.1. If the instrument blank is non-compliant, consider the following suggestions to correct the problem:
  - 12.2.1.1. Rule out instrument contamination by performing the instrument daily maintenance, such as changing septum, cleaning liner, cleaning or using new autosampler syringe.
  - 12.2.1.2. Rule out reagent contamination by testing solvent used for analysis and working internal standard.
  - 12.2.1.3. Rule out preparation contamination by preparing a new instrument blank.
  - 12.2.1.4. If the problem persists, inform the supervisor for further advice.
- 12.2.2. If method blank is non-compliant, consider the following suggestions to correct the problem:
  - 12.2.2.1. Rule out instrument contamination by checking instrument blank.
  - 12.2.2.2. Rule out reagent contamination by testing each reagent used for extraction as described in EMAX-QC01.
  - 12.2.2.3. Rule out glassware contamination used for extraction as described in EMAX-QC07.
  - 12.2.2.4. Re-extract MB and the associated samples with reagents free of contamination or with newly opened reagents.
  - 12.2.2.5. If problem persists, inform the supervisor for further advice.
- 12.2.3. If LCS is non-compliant, consider the following suggestions to correct the problem:
  - 12.2.3.1. If result is bias-high or bias-low, check the LCS Standard by analyzing at the spike level.
  - 12.2.3.2. If LCS check is within 80-120% of expected value, check the calibration of the micropipette or syringe used for spiking. Re-extract and re-analyze the LCS and the associated samples.
  - 12.2.3.3. If LCS check is not within 80-120% of expected value, prepare a fresh LCS standard, re-extract and re-analyze LCS and the associated samples.

## STANDARD OPERATING PROCEDURES

**SEMIVOLATILE ORGANICS BY GC/MS**SOP No.: EMAX-8270 Revision No. 6 Date: 10-Jul-14

12.2.3.4. If LCS is within acceptance then and the right amount of spike is added into sample then it is indicative of matrix interference. Discuss the probable matrix interference in Case Narrative.

12.2.4. If MS is non-compliant, consider the following suggestions to correct the problem:

12.2.4.1. Verify from the sample preparation log that the spike amount added is correct.

12.2.4.2. If LCS is within acceptance criteria and the right amount of spike is added into the sample then it is indicative of matrix interference. Discuss the probability of matrix interference in the case narrative.

**12.3. Analytical Batch QC****12.3.1. Tune Check**

12.3.1.1. If tune check is non-compliant, consider the following suggestion to correct the problem:

- Check the instrument settings and make sure that the instrument parameters are properly set-up.
- Check gas flow.
- Perform auto-tune or visual optimization.
- If the problem persists, inform the supervisor for further actions.

12.3.1.2. If instrument performance is non-compliant, consider the following suggestion to correct the problem:

- Excessive degradation of DDT and/or poor chromatography demonstrated by too much tailing are indications of dirty injection port. Clean or replace the injection port. If problem persist, cut off the first 6-12 inches of the capillary column.

**12.3.2. Initial Calibration (ICAL)**

12.3.2.1. If initial calibration is non-compliant, consider the following suggestions to correct the problem:

- If RSD% is out of acceptance criteria, review result and identify presence of an outlier.
- If one of the standard return a bias-low or bias-high on all of the analytes, then the point is considered an outlier, prepare a standard at the ICAL point and re-analyze.
- If the highest ICAL point appears to be saturated, drop the highest point.
- If the lowest point returns a bias-low response or the peaks are not distinct and sharp, consider the point not usable.

*Note: The lowest calibration identifies the limit of quantitation (LOQ). Therefore, check that the LOQ is in conformance to the current projects where the ICAL will be used.*

12.3.2.2. If instrumentation problem is suspected, consider the following suggestions to correct the problem:

## STANDARD OPERATING PROCEDURES

**SEMIVOLATILE ORGANICS BY GC/MS**SOP No.: EMAX-8270 Revision No. 6 Date: 10-Jul-14

- Check the connections and make sure they are air-tight and perform maintenance as needed.
- Check the gas flow.
- Re-tune the MS.
- Prepare a fresh standard and repeat calibration.
- Clean the MS source and repeat the calibration.

12.3.2.3. If the problem persists, inform the supervisor for further action.

12.3.3. Initial Calibration Verification (ICV)

12.3.3.1. If the ICV is non-compliant, consider the following suggestions to correct the problem:

- Re-analyze ICV to rule out poor injection.
- If ICV is still out of acceptance criteria, prepare a fresh ICAL standard and repeat calibration.
- If ICV is still out of acceptance criteria, prepare a fresh ICAL standard and repeat calibration.
- If problem persist, inform the supervisor for further action.

12.3.4. Daily Calibration Check (DCC)

12.3.4.1. If DCC is non-compliant consider the following suggestions to correct the problem:

- If majority of the analyte response are low and no evidence of leak in the system is apparent, it is indicative of a poor injection or leak in the vial. Re-analyze DCC.
- If problem persist, rule out standard degradation. Prepare a fresh standard and repeat DCC.

12.3.4.2. If Continuing Calibration is non-compliant consider the following suggestions to correct the problem:

- Change the liner.
- Clean the injection port.
- Prepare a new standard.
- Cut or replace column.
- Rule out leaks by checking all connections.
- If continuing calibration is still non-compliant, prepare a new standard and repeat the ICAL.

12.3.5. Instrument Blank: If instrument blank is non-compliant, consider the following suggestions to correct the problem:

- Rule out instrument contamination.

## STANDARD OPERATING PROCEDURES

**SEMIVOLATILE ORGANICS BY GC/MS**SOP No.: EMAX-8270 Revision No. 6 Date: 10-Jul-14

- Rule out reagent contamination by testing each reagent used as described in EMAX-QC01.
  - Rule out vials and glassware contamination as described in EMAX-QC07.
  - If the problem persists, inform the supervisor for further advice.
- 12.4. Discuss in the case narrative, water samples that have residual chlorine above acceptable limits.
- 12.5. Execute a Non-Conformance Report (NCR) when the following circumstances occur:
- 12.5.1. If corrective action needs the function of the department; e.g. if the sample needs to be re-extracted, refer to EMAX-QA08 for details of completing an NCR.
- 12.5.2. If corrective action needs the assistance of the project manager; e.g. if the sample is non-compliant to the technical holding time requirement, insufficient amount of sample, or other non-conforming issues.
- 12.6. For other problems encountered, inform the supervisor immediately for further instruction.

**13.0 POLLUTION PREVENTION**

- 13.1. Observe all necessary precautions to avoid spillage of solvent that may go to wastewater drains.
- 13.2. Prepare all standards in fume hoods.

**14.0 WASTE MANAGEMENT**

- 14.1. No samples shall be dumped on the laboratory sink.
- 14.2. Separate and properly identify all unused and expired analytical standards for proper disposal.
- 14.3. Place all waste generated during analytical process in properly labeled satellite waste containers for proper collection.
- 14.4. Dispose all unused samples, expired analytical standards and other waste generated during the analytical process in accordance to EMAX-SM03.

**15.0 SUPPLEMENTARY NOTES****15.1. Definition of Terms**

- 15.1.1. Analyte – The specific chemicals or components for which a sample is analyzed; may be a group of chemicals that belong to the same chemical family, and which are analyzed together.
- 15.1.2. Batch – is a group of samples that are prepared and/or analyzed at the same time using the same lot of reagents.
- 15.1.2.1. **Preparation Batch** – is composed of one to 20 samples of the same matrix, a method blank, a lab control sample and matrix spike/matrix spike duplicate.
- 15.1.2.2. **Analytical Batch** – is composed of prepared samples (extracts, digestates or concentrates) which are analyzed together as a group using an instrument in conformance to the analytical requirement. An analytical batch can include samples

## STANDARD OPERATING PROCEDURES

**SEMIVOLATILE ORGANICS BY GC/MS**SOP No.: EMAX-8270 Revision No. 6 Date: 10-Jul-14

originating from various matrices, preparation batches, and can exceed 20 samples.

- 15.1.3. Detection Limit (DL) – The lowest concentration or amount of the target analyte that can be identified, measured and reported with confidence that the analyte concentration is not false positive.
- 15.1.4. Limit of Detection (LOD) – An estimate of the minimum amount of substance that an analytical process can reliably detect.
- 15.1.5. Limit of Quantitation (LOQ) – The minimum levels, concentrations or quantities of target variable (e.g., target analyte) that can be reported with a specified degree of confidence.
- 15.1.6. Safety Data Sheet (SDS) – is where the physical data, toxicology and safety precaution of a certain substance is listed.
- 15.1.7. Calibration – is a determinant measured from a standard to obtain the correct value of an instrument output.
- 15.1.8. Carry-over – are contaminants retained in the instruments/apparatus from a highly contaminated sample that is passed into the succeeding sample(s).
- 15.1.9. Calibration Check Compounds (CCC) – evaluate the integrity of the system. Variability of these compounds may indicate system leak or reactive sites in the column.
- 15.1.10. Instrument Method – is a file generated to contain the instrument calibration and instrument parameter settings for a particular analysis.
- 15.1.11. Instrument Blank – is a target-analyte-free solvent subjected to the entire analytical process to establish zero baseline or background value.
- 15.1.12. Method Blank – is a target-analyte-free sample subjected to the entire sample preparation and/or analytical to monitor contamination.
- 15.1.13. Lab Control Sample (LCS) – is a target-analyte-free sample spiked with verified known amount of target analyte(s) or a reference material with a certified known value subjected to the entire sample preparation and/or analytical process. LCS is analyzed to monitor the accuracy of the analytical system.
- 15.1.14. Lab Control Sample Duplicate (LCSD) – is a replicate of LCS analyzed to monitor precision in the absence of MS/MSD sample.
- 15.1.15. Sample – is a specimen received in the laboratory bearing a sample label traceable to the accompanying COC. Samples collected in different containers having the same field sample ID are considered the same and therefore labeled with the same lab sample ID unless otherwise specified by the project.
- 15.1.16. Sample Duplicate – is a replicate of a sub-sample taken from one sample, prepared and analyzed within the same preparation batch.
- 15.1.17. Sub-sample – is an aliquot taken from a sample for analysis. Each sub-sample is uniquely identified by the sample preparation ID.
- 15.1.18. Matrix – is a component or form of a sample.
- 15.1.19. Matrix Spike (MS) – is a sample spiked with a verified known amount of target analyte(s) subjected to the entire sample preparation and/or analytical process. MS is analyzed to monitor matrix effect on a method's recovery efficiency.



## STANDARD OPERATING PROCEDURES

**SEMIVOLATILE ORGANICS BY GC/MS**SOP No.: EMAX-8270 Revision No. 6 Date: 10-Jul-14

- 
- 
- 15.1.20. Matrix Spike Duplicate (MSD) – is a replicate of MS analyzed to monitor precision or recovery.
  - 15.1.21. Response Factor – is the ratio of the peak area of the target compound in the sample or sample extract.
  - 15.1.22. Surrogate – are compounds added to every blank, sample, matrix spike, matrix spike duplicate and standard used to evaluate analytical efficiency by measuring recovery. Compounds not expected to be detected in environmental media.
  - 15.1.23. System Performance Check Compounds (SPCC) – are compounds that are used to check compound stability and to check for degradation cause by contaminated lines or active sites in the system.

**15.2. Application of QC Procedures**

- 15.2.1. The procedures and QC criteria summarized in this SOP shall be applied to all projects when performing Semi Volatile analysis by GC/MS unless otherwise other directive is specified by the project requirements.

**15.3. Department of Defense (DoD) and Department of Energy Projects**

- 15.3.1. Samples from DoD and DoE sponsored projects follows the Quality Assurance Project Plan (QAPP), Statement of Work (SOW) and/or client's quality control directive. In the absence of QAPP, the DoD Quality Systems Manual (QSM), latest update, is applied.

**16.0 REFERENCES**

- 16.1. "Test Methods for Evaluation of Solid Wastes", EPA SW846, Method 8270C as updated
- 16.2. EMAX Quality Systems Manual, as updated

**17.0 APPENDICES****17.1. Tables**

- 17.1.1. Table 1 Intermediate Standard Preparation
  - A) Primary Source B) Secondary Source
- 17.1.2. Table 2A Working Standard Preparation
- 17.1.3. Table 2B Working Standard Preparation for Benzidine
- 17.1.4. Table 2C Working Standard Preparation for Additional Analytes (Appendix IX)
- 17.1.5. Table 3A Working Secondary Source Standard
- 17.1.6. Table 3B Working Secondary Source Standard for Benzidine
- 17.1.7. Table 3C Working Secondary Source Standard for Additional Analytes "Appendix IX"
- 17.1.8. Table 4 Working Internal Standard Preparation
- 17.1.9. Table 5 Working GC/MS Tuning (DFTPP) Standard
- 17.1.10. Table 6 Instrument Parameters

## STANDARD OPERATING PROCEDURES

**SEMIVOLATILE ORGANICS BY GC/MS**SOP No.: EMAX-8270 Revision No. 6 Date: 10-Jul-14

- 
- 
- 17.1.11. Table 7 DFTPP Key Ions and Ion Abundance Criteria for 8270C
  - 17.1.12. Table 8 Typical Analyte List, Quantitation Ions, IS, Surrogates, Calibration Standards and Detection Limits
  - 17.1.13. Table 9 Typical Analyte List, Quantitation Ions, IS, Surrogates, Calibration Standards and Detection Limits for Appendix IX
  - 17.1.14. Table 10 Calibration Check Compounds (CCCs)
  - 17.1.15. Table 11 System Performance Calibration Check Compounds (SPCCs)
  - 17.2. **Figures**
    - 17.2.1. Figure 1 Peak Evaluation Technique
    - 17.2.2. Figure 2 Typical Chromatogram
    - 17.2.3. Figure 2A Typical Chromatogram of Benzidine
    - 17.2.4. Figure 2B Typical Chromatogram of Additional Analytes "Appendix IX"
    - 17.2.5. Figure 3 Typical ICAL Summary
    - 17.2.6. Figure 3A Typical ICAL Summary of Benzidine
    - 17.2.7. Figure 3B Typical ICAL Summary of Appendix IX
    - 17.2.8. Figure 3C Typical ICAL Summary of Additional Analytes Appendix IX
    - 17.2.9. Figure 4 Typical DFTPP Tune Summary "8270C"
    - 17.2.10. Figure 5 Typical Instrument Performance Check Summary "8270C"
    - 17.2.11. Figure 6 Typical Continuing Calibration Summary
    - 17.2.12. Figure 6A Typical Continuing Calibration Summary of Benzidine
    - 17.2.13. Figure 6B Typical Continuing Calibration Summary of "Appendix IX"
    - 17.2.14. Figure 6C Typical Continuing Calibration Summary of Additional Analytes "Appendix IX"
    - 17.2.15. Figure 7A Typical Internal Standard and Retention Time Summary SV-1
    - 17.2.16. Figure 7B Typical Internal Standard and Retention Time Summary SV-2
    - 17.2.17. Figure 8 Typical Sample Result Summary
    - 17.2.18. Figure 9 Typical LCS/LCSD Report Summary
    - 17.2.19. Figure 10 Typical MS/MSD Report Summary
    - 17.2.20. Figure 11 Typical Case Narrative
  - 17.3. **Appendices**
    - 17.3.1. Appendix 1 Summary of Quality Control Procedures
    - 17.3.2. Appendix 2 Demonstration of Capability
    - 17.3.3. Appendix 3 Demonstration of Capability for Appendix IX Compounds
  - 17.4. **Forms**

STANDARD OPERATING PROCEDURES

**SEMIVOLATILE ORGANICS BY GC/MS**

SOP No.: EMAX-8270 Revision No. 6 Date: 10-Jul-14

---

---

- 17.4.1. 8270FS Sample Preparation Log
- 17.4.2. 8270FA Analytical Run Log
- 17.4.3. 8270FM Instrument Maintenance Log

**Table 1: INTERMEDIATE STANDARD PREPARATION**

**A. Primary Source: Restek, CPI, AccuStandard or equivalent**

| Standard Name | Stock / Internal Soln. Conc. (µg/mL)      | Source | Preparation  |               |                 | Final Conc. (µg/mL) |     |
|---------------|---|--------|--------------|---------------|-----------------|---------------------|-----|
|               |   |        | Aliquot (µL) | Dil. Solution | Final Vol. (mL) |                     |     |
| Standard List | 8270 Mega Mix                             | 1000   | Restek       | 1000          | MeCl2           | 5                   | 200 |
|               | 8270 Custom Std.                          | 2000   | CPI          | 500           | MeCl2           | 5                   | 200 |
|               | Benzidine Mix                             | 2000   | Restek       | 500           | MeCl2           | 5                   | 200 |
|               | Benzoic Mix                               | 2000   | Restek       | 500           | MeCl2           | 5                   | 200 |
|               | Acid Surrogate Mix                        | 7500   | Restek       | 133.3         | MeCl2           | 5                   | 200 |
|               | Base/Neutral Surrogate Mix                | 5000   | Restek       | 200           | MeCl2           | 5                   | 200 |
| Appendix IX   | Appendix IX Mix # 1                       | 2000   | Restek       | 300           | MeCl2           | 5                   | 120 |
|               | Appendix IX Mix # 2                       | 1000   | Restek       | 600           | MeCl2           | 5                   | 120 |
|               | EPA 8270 Organophosphorous Pesticides Mix | 2000   | Restek       | 300           | MeCl2           | 5                   | 120 |
|               | Cust. 8270 Std.                           | 2000   | AccuStandard | 300           | MeCl2           | 5                   | 120 |
|               | Acid Surrogate Mix                        | 7500   | Restek       | 80            | MeCl2           | 5                   | 120 |
|               | Base/Neutral Surrogate Mix                | 5000   | Restek       | 120           | MeCl2           | 5                   | 120 |

**B. Secondary Source: CPI, AccuStandard, Restek or equivalent**

| Standard Name | Stock / Internal Soln. Conc. (µg/mL)       | Source | Preparation  |               |                 | Final Conc. (µg/mL) |     |
|---------------|--|--------|--------------|---------------|-----------------|---------------------|-----|
|               |  |        | Aliquot (µL) | Dil. Solution | Final Vol. (mL) |                     |     |
| Standard List | Custom Semi Volatile Standard              | 2000   | CPI          | NA            | NA              | NA                  | NA  |
|               | 8270 LCS Solution                          | 200    | CPI          |               |                 |                     |     |
|               | 8270 Internal Standard                     | 2000   | AccuStandard |               |                 |                     |     |
|               | Benzidine                                  | 5000   | Ultra        |               |                 |                     |     |
| Appendix IX   | Appendix IX Mix # 1*                       | 2000   | Restek       | 300           | MeCl2 / MeOH    | 5                   | 120 |
|               | Appendix IX Mix # 2*                       | 1000   | Restek       | 600           | MeCl2 / MeOH    | 5                   | 120 |
|               | EPA 8270 Organophosphorous Pesticides Mix* | 2000   | Restek       | 300           | MeCl2 / MeOH    | 5                   | 120 |
|               | Cust. 8270 Std.                            | 2000   | CPI          | 300           | MeCl2 / MeOH    | 5                   | 120 |

\*Different Lot

**Table 1 (cont.): INTERMEDIATE STANDARD PREPARATION**

**a. Primary Source: Restek, SPEXertificate, AccuStandard, Ultra Scientific or equivalent**

| Standard Name             |                | Stock / Internal<br>Soln. Conc.<br>(µg/mL) | Source           | Preparation     |                   |                    | Final<br>Conc.<br>(µg/mL) |
|---------------------------|----------------|--|------------------|-----------------|-------------------|--------------------|---------------------------|
|                           |                |  |                  | Aliquot<br>(µL) | Dil.<br>Solution  | Final<br>Vol. (mL) |                           |
| Standard List             | Benzidine      | 1000                                       | Restek           | NA              | NA                | NA                 | NA                        |
| Appendix IX<br>Additional | Kepone         | 2000                                       | SPEXertificate   | 750             | MeCl <sub>2</sub> | 5                  | 300                       |
|                           | Famphur        | 2000                                       | AccuStandard     | 750             | MeCl <sub>2</sub> | 5                  | 300                       |
|                           | Hexachloropene | 5000                                       | Ultra Scientific | 300             | MeCl <sub>2</sub> | 5                  | 300                       |

**b. Secondary Source: CPI, Supelco or equivalent**

| Standard Name             |                | Stock / Internal<br>Soln. Conc.<br>(µg/mL) | Source  | Preparation     |                             |                    | Final<br>Conc.<br>(µg/mL) |
|---------------------------|----------------|--|---------|-----------------|-----------------------------|--------------------|---------------------------|
|                           |                |  |         | Aliquot<br>(µL) | Dil.<br>Solution            | Final<br>Vol. (mL) |                           |
| Appendix IX<br>Additional | Kepone         | 2000                                       | CPI     | 750             | MeCl <sub>2</sub> /<br>MeOH | 5                  | 300                       |
|                           | Famphur        | 2000                                       | CPI     | 750             | MeCl <sub>2</sub> /<br>MeOH | 5                  | 300                       |
|                           | Hexachloropene | 5000                                       | Supelco | 300             | MeCl <sub>2</sub> /<br>MeOH | 5                  | 300                       |

**Table 2A: INITIAL CALIBRATION  
 WORKING STANDARD PREPARATION**

| Standard Name | Intermediate Standard<br>μL of 200 mg/L | Internal Standard<br>μL of 2000 mg/L | Dil. Solvent      | Final Volume<br>(μL) | Final Conc.  |
|---------------|---|--------------------------------------|-------------------|----------------------|--|
| 1             | 10                                      | 10                                   | MeCl <sub>2</sub> | 500                  | 4 μg/mL of Cal. Std.<br>40 μg/mL of Internal Std.  |
| 2             | 25                                      | 10                                   | MeCl <sub>2</sub> | 500                  | 10 μg/mL of Cal. Std.<br>40 μg/mL of Internal Std. |
| 3             | 50                                      | 10                                   | MeCl <sub>2</sub> | 500                  | 20 μg/mL of Cal. Std.<br>40 μg/mL of Internal Std. |
| 4             | 62.5                                    | 10                                   | MeCl <sub>2</sub> | 500                  | 25 μg/mL of Cal. Std.<br>40 μg/mL of Internal Std. |
| 5             | 75                                      | 10                                   | MeCl <sub>2</sub> | 500                  | 30 μg/mL of Cal. Std.<br>40 μg/mL of Internal Std. |
| 6             | 100                                     | 10                                   | MeCl <sub>2</sub> | 500                  | 40 μg/mL of Cal. Std.<br>40 μg/mL of Internal Std. |
| 7             | 125                                     | 10                                   | MeCl <sub>2</sub> | 500                  | 50 μg/mL of Cal. Std.<br>40 μg/mL of Internal Std. |

**Table 2B: INITIAL CALIBRATION  
 WORKING STANDARD PREPARATION FOR BENZIDINE**

| Standard Name | Intermediate Standard<br>μL of 1000 mg/L | Internal Standard<br>μL of 2000 mg/L | Dil. Solvent      | Final Volume<br>(μL) | Final Conc.  |
|---------------|--|--------------------------------------|-------------------|----------------------|--|
| 1             | 2  | 10                                   | MeCl <sub>2</sub> | 500                  | 4 μg/mL of Benzidine Std.<br>40 μg/mL of Internal Std.   |
| 2             | 5  | 10                                   | MeCl <sub>2</sub> | 500                  | 10 μg/mL of Benzidine Std.<br>40 μg/mL of Internal Std.  |
| 3             | 12.5                                     | 10                                   | MeCl <sub>2</sub> | 500                  | 25 μg/mL of Benzidine Std.<br>40 μg/mL of Internal Std.  |
| 4             | 20                                       | 10                                   | MeCl <sub>2</sub> | 500                  | 40 μg/mL of Benzidine Std.<br>40 μg/mL of Internal Std.  |
| 5             | 25                                       | 10                                   | MeCl <sub>2</sub> | 500                  | 50 μg/mL of Benzidine Std.<br>40 μg/mL of Internal Std.  |
| 6             | 40                                       | 10                                   | MeCl <sub>2</sub> | 500                  | 80 μg/mL of Benzidine Std.<br>40 μg/mL of Internal Std.  |
| 7             | 50                                       | 10                                   | MeCl <sub>2</sub> | 500                  | 100 μg/mL of Benzidine Std.<br>40 μg/mL of Internal Std. |

**Table 2C:** **INITIAL CALIBRATION**  
**WORKING STANDARD PREPARATION**  
**FOR ADDITIONAL ANALYTES (APPENDIX IX)**

**Appendix IX Standard List**

| Standard Name | Intermediate Standard<br>μL of 120 mg/L | Internal Standard<br>μL of 2000 mg/L | Dil. Solvent      | Final Volume<br>(μL) | Final Conc.  |
|---------------|---|--------------------------------------|-------------------|----------------------|--|
| 1             | 16.7                                    | 10                                   | MeCl <sub>2</sub> | 500                  | 4 μg/mL of Cal. Std.<br>40 μg/mL of Internal Std.  |
| 2             | 41.6                                    | 10                                   | MeCl <sub>2</sub> | 500                  | 10 μg/mL of Cal. Std.<br>40 μg/mL of Internal Std. |
| 3             | 83.3                                    | 10                                   | MeCl <sub>2</sub> | 500                  | 20 μg/mL of Cal. Std.<br>40 μg/mL of Internal Std. |
| 4             | 104.2                                   | 10                                   | MeCl <sub>2</sub> | 500                  | 25 μg/mL of Cal. Std.<br>40 μg/mL of Internal Std. |
| 5             | 125                                     | 10                                   | MeCl <sub>2</sub> | 500                  | 30 μg/mL of Cal. Std.<br>40 μg/mL of Internal Std. |
| 6             | 166.7                                   | 10                                   | MeCl <sub>2</sub> | 500                  | 40 μg/mL of Cal. Std.<br>40 μg/mL of Internal Std. |
| 7             | 208.3                                   | 10                                   | MeCl <sub>2</sub> | 500                  | 50 μg/mL of Cal. Std.<br>40 μg/mL of Internal Std. |

**Appendix IX Additional**

| Standard Name | Intermediate Standard<br>μL of 300 mg/L | Internal Standard<br>μL of 2000 mg/L | Dil. Solvent      | Final Volume<br>(μL) | Final Conc.   |
|---------------|---|--------------------------------------|-------------------|----------------------|---|
| 1             | 33.3                                    | 10                                   | MeCl <sub>2</sub> | 500                  | 20 μg/mL of Cal. Std.<br>40 μg/mL of Internal Std.  |
| 2             | 66.6                                    | 10                                   | MeCl <sub>2</sub> | 500                  | 40 μg/mL of Cal. Std.<br>40 μg/mL of Internal Std.  |
| 3             | 83.3                                    | 10                                   | MeCl <sub>2</sub> | 500                  | 50 μg/mL of Cal. Std.<br>40 μg/mL of Internal Std.  |
| 4             | 133.3                                   | 10                                   | MeCl <sub>2</sub> | 500                  | 80 μg/mL of Cal. Std.<br>40 μg/mL of Internal Std.  |
| 5             | 166.6                                   | 10                                   | MeCl <sub>2</sub> | 500                  | 100 μg/mL of Cal. Std.<br>40 μg/mL of Internal Std. |
| 6             | 200                                     | 10                                   | MeCl <sub>2</sub> | 500                  | 120 μg/mL of Cal. Std.<br>40 μg/mL of Internal Std. |
| 7             | 233.3                                   | 10                                   | MeCl <sub>2</sub> | 500                  | 140 μg/mL of Cal. Std.<br>40 μg/mL of Internal Std. |

**Table 3A: WORKING SECONDARY SOURCE STANDARD**

| Standard Name                 | Soln. Conc.<br>(µg/mL) | Preparation     |                   |                    | Final Conc.<br>(µg/mL) |
|-------------------------------|------------------------|-----------------|-------------------|--------------------|------------------------|
|                               |                        | Aliquot<br>(µL) | Dil.<br>Solution  | Final<br>Vol. (µL) |                        |
| Custom Semi Volatile Standard | 2000                   | 6.25            | MeCl <sub>2</sub> | 500                | 25                     |
| 8270 LCS Solution             | 200                    | 62.5            | MeCl <sub>2</sub> | 500                | 25                     |
| 8270 Internal Standard        | 2000                   | 10              | MeCl <sub>2</sub> | 500                | 40                     |

**Table 3B: WORKING SECONDARY SOURCE STANDARD  
FOR BENZIDINE**

| Standard Name          | Soln. Conc.<br>(µg/mL) | Preparation     |                   |                    | Final Conc.<br>(µg/mL) |
|------------------------|------------------------|-----------------|-------------------|--------------------|------------------------|
|                        |                        | Aliquot<br>(µL) | Dil.<br>Solution  | Final<br>Vol. (µL) |                        |
| Benzidine              | 5000                   | 2.5             | MeCl <sub>2</sub> | 500                | 25                     |
| 8270 Internal Standard | 2000                   | 10              | MeCl <sub>2</sub> | 500                | 40                     |

**Table 3C: WORKING SECONDARY SOURCE STANDARD  
FOR ADDITIONAL ANALYTES APPENDIX IX**

**Appendix IX Standard List**

| Standard Name          | Soln. Conc.<br>(µg/mL) | Preparation     |                   |                    | Final Conc.<br>(µg/mL) |
|------------------------|------------------------|-----------------|-------------------|--------------------|------------------------|
|                        |                        | Aliquot<br>(µL) | Dil.<br>Solution  | Final<br>Vol. (µL) |                        |
| Appendix IX Spike      | 120                    | 104.2           | MeCl <sub>2</sub> | 500                | 25                     |
| 8270 Internal Standard | 2000                   | 10              | MeCl <sub>2</sub> | 500                | 40                     |

**Appendix IX Additional**

| Standard Name          | Soln. Conc.<br>(µg/mL) | Preparation     |                   |                    | Final Conc.<br>(µg/mL) |
|------------------------|------------------------|-----------------|-------------------|--------------------|------------------------|
|                        |                        | Aliquot<br>(µL) | Dil.<br>Solution  | Final<br>Vol. (µL) |                        |
| Appendix IX Add. Spike | 300                    | 83.3            | MeCl <sub>2</sub> | 500                | 50                     |
| 8270 Internal Standard | 2000                   | 10              | MeCl <sub>2</sub> | 500                | 40                     |



**Table 4: WORKING INTERNAL STANDARD PREPARATION**

| Standard Name         | Soln. Conc.<br>(µg/mL) | Preparation     |                   |                    | Final Conc.<br>(µg/mL) |
|-----------------------|------------------------|-----------------|-------------------|--------------------|------------------------|
|                       |                        | Aliquot<br>(mL) | Dil.<br>Solution  | Final<br>Vol. (mL) |                        |
| Internal Standard Mix | 4000                   | 5               | MeCl <sub>2</sub> | 10                 | 2000                   |

**Table 5: WORKING GC/MS TUNING (DFTPP) STANDARD**

| Standard Name    | Soln. Conc.<br>(µg/mL) | Preparation     |                   |                    | Final Conc.<br>(µg/mL) |
|------------------|------------------------|-----------------|-------------------|--------------------|------------------------|
|                  |                        | Aliquot<br>(µL) | Dil.<br>Solution  | Final<br>Vol. (µL) |                        |
| GC/MS Tuning Mix | 1000                   | 25              | MeCl <sub>2</sub> | 500                | 50                     |

**Table 6: INSTRUMENT PARAMETERS**

|                                 | Inst. E4 / Inst. E7   | Inst. E9 / Inst. F0                     |
|---------------------------------|---|---|
| Carrier Gas                     | Helium at 100 psi at outlet   | Helium at 100 psi at outlet             |
| Column head pressure            | 15 - 35 psi at 40°C   | 15-35 psi at 45°C                       |
| Injection port temperature      | 280-300°C   | 200-250°C                               |
| Interface                       | Direct column interference at 280-300°C   | Direct column interference at 280-300°C |
| Valve time                      | Split 0.2 minute  | Split 0.2 minutes                       |
| <b>Oven Temperature Program</b> |   |   |
| Initial Temperature             | 50°C/min; hold for 0min.  | 45°C/min; hold for 0.2min.              |
| Rate                            | 30°C/min to 100°C; hold for 0.0 min.;<br>20°C/min to 200°C; hold for 0.0 min.;<br>25°C/min to 320°C; hold for 2.53 min. | 20°C/min to 320°C; hold for 4 min.      |
| Run Time                        | 14 minutes  | 18 minutes                              |
| <b>Scan Parameters</b>          |   |   |
| Scan start time                 | After solvent peak  | After solvent peak                      |
| Mass range                      | 40 to 550 AMU   | 40 to 550 AMU                           |
| Multiplier voltage              | 1000 - 3000   | 1000 - 3000                             |
| Number of sampling rate         | 1 - 2   | 1 - 2                                   |
| Threshold                       | 0 - 300   | 0 - 300                                 |
| Tuning File                     | DFTPP   | DFTPP                                   |

**Table 7: DFTTPP KEY IONS ABUNDANCE CRITERIA  
FOR 8270C**

---

| <b>Mass</b> | <b>Ion Abundance Criteria</b>      |
|-------------|------------------------------------|
| 51          | 30 – 60% of mass 198               |
| 68          | < 2.0% of mass 69                  |
| 69          | Present                            |
| 70          | < 2.0% of mass 69                  |
| 127         | 40 – 60% of mass 198               |
| 197         | < 1% of mass 198                   |
| 198         | Base peak, 100% relative abundance |
| 199         | 5 - 9% of mass 198                 |
| 275         | 10 – 30% of mass 198               |
| 365         | > 1% of mass 198                   |
| 441         | Present but < mass 443             |
| 442         | > 40% of mass 198                  |
| 443         | 17 – 23% of mass 442               |

**Table 8: TYPICAL TARGET ANALYTE LIST**

| Analyte                       | Quantitation Ions |           | IS  | SUR    | ICAL ANALYTE CONCENTRATIONS (µg/L) |    |    |    |    |    |    |     | ICV/DCC EV(µg/L) | LCS/MS EV(µg/L) | WATER |     |     |      | SOIL |     |      |       |
|-------------------------------|-------------------|-----------|-----|--------|------------------------------------|----|----|----|----|----|----|-----|------------------|-----------------|-------|-----|-----|------|------|-----|------|-------|
|                               | Primary           | Secondary |     |        | 1                                  | 2  | 3  | 4  | 5  | 6  | 7  | 8   |                  |                 | DL    | LOD | LOQ | Unit | DL   | LOD | LOQ  | Unit  |
| Acenaphthene                  | 153               | 152       | IS3 | Sur4   | 4                                  | 10 | 20 | 25 | 40 | 50 |    |     | 25               | 40              | 2.5   | 5   | 10  | µg/L | 83   | 167 | 333  | µg/Kg |
| Acenaphthylene                | 152               | 151       | IS3 | Sur4   | 4                                  | 10 | 20 | 25 | 40 | 50 |    |     | 25               | 40              | 2.5   | 5   | 10  | µg/L | 83   | 167 | 333  | µg/Kg |
| Aniline                       | 93                | 66        | IS1 | Sur1/2 | 4                                  | 10 | 20 | 25 | 40 | 50 |    |     | 25               | 40              | 5.3   | 10  | 20  | µg/L | 83   | 167 | 667  | µg/Kg |
| Anthracene                    | 178               | 152       | IS4 | Sur5   | 4                                  | 10 | 20 | 25 | 40 | 50 |    |     | 25               | 40              | 2.5   | 5   | 10  | µg/L | 83   | 167 | 333  | µg/Kg |
| Azobenzene*                   | 77                | 105       | IS4 | Sur5   | 4                                  | 10 | 20 | 25 | 40 | 50 |    |     | 25               | 40              | 2.5   | 5   | 10  | µg/L | 96   | 167 | 333  | µg/Kg |
| Benzo(a)anthracene            | 228.1             | 113       | IS5 | Sur6   | 4                                  | 10 | 20 | 25 | 40 | 50 |    |     | 25               | 40              | 2.5   | 5   | 10  | µg/L | 83   | 167 | 333  | µg/Kg |
| Benzo(a)pyrene                | 252.1             | 125       | IS6 | Sur6   | 4                                  | 10 | 20 | 25 | 40 | 50 |    |     | 25               | 40              | 2.5   | 5   | 10  | µg/L | 83   | 167 | 333  | µg/Kg |
| Benzo(b)fluoranthene          | 252.1             | 124.9     | IS6 | Sur6   | 4                                  | 10 | 20 | 25 | 40 | 50 |    |     | 25               | 40              | 2.6   | 5   | 10  | µg/L | 86   | 167 | 333  | µg/Kg |
| Benzo(e)pyrene                | 252.1             | 125       | IS6 | Sur6   | 4                                  | 10 | 20 | 25 | 40 | 50 |    |     | 25               | 40              | 2.5   | 5   | 10  | µg/L | 83   | 167 | 333  | µg/Kg |
| Benzo(g,h,i)perylene          | 276.1             | 137.9     | IS6 | Sur6   | 4                                  | 10 | 20 | 25 | 40 | 50 |    |     | 25               | 40              | 2.5   | 5   | 10  | µg/L | 87   | 167 | 333  | µg/Kg |
| Benzo(k)fluoranthene          | 252.1             | 124.9     | IS6 | Sur6   | 4                                  | 10 | 20 | 25 | 40 | 50 |    |     | 25               | 40              | 2.5   | 5   | 10  | µg/L | 83   | 167 | 333  | µg/Kg |
| Benzoic acid                  | 105               | 77        | IS2 | Sur3   | 4                                  | 10 | 20 | 25 | 40 | 50 | 80 | 100 | 25               | 80              | 10    | 20  | 40  | µg/L | 333  | 667 | 1333 | µg/Kg |
| Benzyl alcohol                | 108               | 79        | IS1 | Sur1/2 | 4                                  | 10 | 20 | 25 | 40 | 50 |    |     | 25               | 40              | 2.5   | 5   | 10  | µg/L | 83   | 167 | 333  | µg/Kg |
| Biphenyl                      | 154               | 153       | IS3 | Sur4   | 4                                  | 10 | 20 | 25 | 40 | 50 |    |     | 25               | 40              | 2.5   | 5   | 10  | µg/L | 83   | 167 | 333  | µg/Kg |
| Bis (2-Chloroethoxy) methane  | 92.9              | 94.9      | IS2 | Sur3   | 4                                  | 10 | 20 | 25 | 40 | 50 |    |     | 25               | 40              | 2.5   | 5   | 10  | µg/L | 83   | 167 | 333  | µg/Kg |
| Bis (2-Chloroethyl) ether     | 92.9              | 62.9      | IS1 | Sur1/2 | 4                                  | 10 | 20 | 25 | 40 | 50 |    |     | 25               | 40              | 2.5   | 5   | 10  | µg/L | 83   | 167 | 333  | µg/Kg |
| Bis (2-chloroisopropyl) ether | 45                | 76.9      | IS1 | Sur1/2 | 4                                  | 10 | 20 | 25 | 40 | 50 |    |     | 25               | 40              | 2.5   | 5   | 10  | µg/L | 83   | 167 | 333  | µg/Kg |
| Bis(2-ethylhexyl)adipate      | 129               | 57        | IS5 | Sur6   | 4                                  | 10 | 20 | 25 | 40 | 50 |    |     | 25               | 40              | 2.5   | 5   | 10  | µg/L | 87   | 167 | 333  | µg/Kg |
| bis(2-Ethylhexyl)phthalate    | 149               | 167       | IS5 | Sur6   | 4                                  | 10 | 20 | 25 | 40 | 50 |    |     | 25               | 40              | 2.5   | 5   | 10  | µg/L | 115  | 167 | 333  | µg/Kg |
| 4-Bromophenyl-phenylether     | 247.9             | 250       | IS4 | Sur5   | 4                                  | 10 | 20 | 25 | 40 | 50 |    |     | 25               | 40              | 2.5   | 5   | 10  | µg/L | 90   | 167 | 333  | µg/Kg |
| Butylbenzylphthalate          | 149               | 91        | IS5 | Sur6   | 4                                  | 10 | 20 | 25 | 40 | 50 |    |     | 25               | 40              | 2.5   | 5   | 10  | µg/L | 83   | 167 | 333  | µg/Kg |
| Carbazole                     | 167               | 139       | IS4 | Sur5   | 4                                  | 10 | 20 | 25 | 40 | 50 |    |     | 25               | 40              | 2.5   | 5   | 10  | µg/L | 89   | 167 | 333  | µg/Kg |
| 4-Chloro-3-methylphenol       | 107               | 77        | IS2 | Sur3   | 4                                  | 10 | 20 | 25 | 40 | 50 |    |     | 25               | 40              | 2.5   | 5   | 10  | µg/L | 83   | 167 | 333  | µg/Kg |
| 4-Chloroaniline               | 127               | 129       | IS2 | Sur3   | 4                                  | 10 | 20 | 25 | 40 | 50 |    |     | 25               | 40              | 4.2   | 5   | 10  | µg/L | 83   | 167 | 333  | µg/Kg |
| 2-Chloronaphthalene           | 162               | 164       | IS3 | Sur4   | 4                                  | 10 | 20 | 25 | 40 | 50 |    |     | 25               | 40              | 2.5   | 5   | 10  | µg/L | 83   | 167 | 333  | µg/Kg |
| 2-Chlorophenol                | 127.9             | 64        | IS1 | Sur1/2 | 4                                  | 10 | 20 | 25 | 40 | 50 |    |     | 25               | 40              | 2.5   | 5   | 10  | µg/L | 83   | 167 | 333  | µg/Kg |
| 4-Chlorophenyl-phenylether    | 204               | 206       | IS3 | Sur4   | 4                                  | 10 | 20 | 25 | 40 | 50 |    |     | 25               | 40              | 2.5   | 5   | 10  | µg/L | 83   | 167 | 333  | µg/Kg |
| Chrysene                      | 228.1             | 226.1     | IS5 | Sur6   | 4                                  | 10 | 20 | 25 | 40 | 50 |    |     | 25               | 40              | 2.5   | 5   | 10  | µg/L | 83   | 167 | 333  | µg/Kg |
| Dibenzo(a,h)anthracene        | 278.1             | 139       | IS6 | Sur6   | 4                                  | 10 | 20 | 25 | 40 | 50 |    |     | 25               | 40              | 2.5   | 5   | 10  | µg/L | 83   | 167 | 333  | µg/Kg |
| Dibenzofuran                  | 168               | 139       | IS3 | Sur4   | 4                                  | 10 | 20 | 25 | 40 | 50 |    |     | 25               | 40              | 2.5   | 5   | 10  | µg/L | 83   | 167 | 333  | µg/Kg |
| 1,2-Dichlorobenzene           | 145.9             | 147.9     | IS1 | Sur1/2 | 4                                  | 10 | 20 | 25 | 40 | 50 |    |     | 25               | 40              | 2.5   | 5   | 10  | µg/L | 83   | 167 | 333  | µg/Kg |
| 1,3-Dichlorobenzene           | 145.9             | 147.9     | IS1 | Sur1/2 | 4                                  | 10 | 20 | 25 | 40 | 50 |    |     | 25               | 40              | 2.5   | 5   | 10  | µg/L | 83   | 167 | 333  | µg/Kg |
| 1,4-Dichlorobenzene           | 145.9             | 147.9     | IS1 | Sur1/2 | 4                                  | 10 | 20 | 25 | 40 | 50 |    |     | 25               | 40              | 2.5   | 5   | 10  | µg/L | 83   | 167 | 333  | µg/Kg |
| 3,3'-Dichlorobenzidine        | 252               | 254       | IS5 | Sur6   | 4                                  | 10 | 20 | 25 | 40 | 50 |    |     | 25               | 40              | 2.5   | 5   | 10  | µg/L | 84   | 167 | 333  | µg/Kg |
| 2,4-Dichlorophenol            | 161.9             | 163.9     | IS2 | Sur3   | 4                                  | 10 | 20 | 25 | 40 | 50 |    |     | 25               | 40              | 2.5   | 5   | 10  | µg/L | 83   | 167 | 333  | µg/Kg |
| Diethylphthalate              | 149               | 177       | IS3 | Sur4   | 4                                  | 10 | 20 | 25 | 40 | 50 |    |     | 25               | 40              | 2.5   | 5   | 10  | µg/L | 83   | 167 | 333  | µg/Kg |
| 2,6-Dimethylnaphthalene       | 156               | 141       | IS3 | Sur4   | 4                                  | 10 | 20 | 25 | 40 | 50 |    |     | 25               | 40              | 2.5   | 5   | 10  | µg/L | 83   | 167 | 333  | µg/Kg |
| 2,4-Dimethylphenol            | 107               | 122       | IS2 | Sur3   | 4                                  | 10 | 20 | 25 | 40 | 50 |    |     | 25               | 40              | 2.6   | 5   | 10  | µg/L | 83   | 167 | 333  | µg/Kg |

**Table 8: TYPICAL TARGET ANALYTE LIST**

| Analyte                    | Quantitation Ions |           | IS  | SUR    | ICAL ANALYTE CONCENTRATIONS (µg/L) |    |    |    |    |    |    |     | ICV/DCC<br>EV(µg/L) | LCS/MS<br>EV(µg/L) | WATER |     |     |      | SOIL |     |      |       |
|----------------------------|-------------------|-----------|-----|--------|------------------------------------|----|----|----|----|----|----|-----|---------------------|--------------------|-------|-----|-----|------|------|-----|------|-------|
|                            | Primary           | Secondary |     |        | 1                                  | 2  | 3  | 4  | 5  | 6  | 7  | 8   |                     |                    | DL    | LOD | LOQ | Unit | DL   | LOD | LOQ  | Unit  |
| 3,4-Dimethylphenol         | 107               | 122       | IS2 | Sur3   | 4                                  | 10 | 20 | 25 | 40 | 50 |    |     | 25                  | 40                 | 2.5   | 5   | 10  | µg/L | 83   | 167 | 333  | µg/Kg |
| Dimethylphthalate          | 163               | 164       | IS3 | Sur4   | 4                                  | 10 | 20 | 25 | 40 | 50 |    |     | 25                  | 40                 | 2.5   | 5   | 10  | µg/L | 83   | 167 | 333  | µg/Kg |
| Di-n-butylphthalate        | 149               | 150       | IS4 | Sur5   | 4                                  | 10 | 20 | 25 | 40 | 50 |    |     | 25                  | 40                 | 2.5   | 5   | 10  | µg/L | 97   | 167 | 333  | µg/Kg |
| 4,6-Dinitro-2-methylphenol | 198               | 121       | IS4 | Sur5   | 4                                  | 10 | 20 | 25 | 40 | 50 |    |     | 25                  | 40                 | 2.5   | 5   | 10  | µg/L | 83   | 167 | 333  | µg/Kg |
| 1,3-Dinitrobenzene         | 168               | 75        | IS3 | Sur4   | 4                                  | 10 | 20 | 25 | 40 | 50 |    |     | 25                  | 40                 | 2.5   | 5   | 10  | µg/L | 83   | 167 | 333  | µg/Kg |
| 2,4-Dinitrophenol          | 184               | 106.9     | IS3 | Sur4   | 4                                  | 10 | 20 | 25 | 40 | 50 |    |     | 25                  | 40                 | 2.5   | 5   | 10  | µg/L | 86   | 167 | 333  | µg/Kg |
| 2,4-Dinitrotoluene         | 165               | 89        | IS3 | Sur4   | 4                                  | 10 | 20 | 25 | 40 | 50 |    |     | 25                  | 40                 | 2.5   | 5   | 10  | µg/L | 83   | 167 | 333  | µg/Kg |
| 2,6-Dinitrotoluene         | 165               | 89        | IS3 | Sur4   | 4                                  | 10 | 20 | 25 | 40 | 50 |    |     | 25                  | 40                 | 2.5   | 5   | 10  | µg/L | 83   | 167 | 333  | µg/Kg |
| Di-n-octylphthalate        | 149               | 150       | IS6 | Sur6   | 4                                  | 10 | 20 | 25 | 40 | 50 |    |     | 25                  | 40                 | 2.5   | 5   | 10  | µg/L | 97   | 167 | 333  | µg/Kg |
| Fluoranthene               | 202               | 100.9     | IS4 | Sur5   | 4                                  | 10 | 20 | 25 | 40 | 50 |    |     | 25                  | 40                 | 2.5   | 5   | 10  | µg/L | 126  | 167 | 333  | µg/Kg |
| Fluorene                   | 166               | 165       | IS3 | Sur4   | 4                                  | 10 | 20 | 25 | 40 | 50 |    |     | 25                  | 40                 | 2.5   | 5   | 10  | µg/L | 83   | 167 | 333  | µg/Kg |
| Hexachlorobenzene          | 283.8             | 141.9     | IS4 | Sur5   | 4                                  | 10 | 20 | 25 | 40 | 50 |    |     | 25                  | 40                 | 2.5   | 5   | 10  | µg/L | 83   | 167 | 333  | µg/Kg |
| Hexachlorobutadiene        | 224.8             | 222.8     | IS2 | Sur3   | 4                                  | 10 | 20 | 25 | 40 | 50 |    |     | 25                  | 40                 | 2.5   | 5   | 10  | µg/L | 83   | 167 | 333  | µg/Kg |
| Hexachlorocyclopentadiene  | 236.8             | 234.8     | IS3 | Sur4   | 4                                  | 10 | 20 | 25 | 40 | 50 |    |     | 25                  | 40                 | 2.5   | 5   | 10  | µg/L | 83   | 167 | 333  | µg/Kg |
| Hexachloroethane           | 116.8             | 200.8     | IS1 | Sur1/2 | 4                                  | 10 | 20 | 25 | 40 | 50 |    |     | 25                  | 40                 | 2.5   | 5   | 10  | µg/L | 83   | 167 | 333  | µg/Kg |
| Indeno(1,2,3-cd)pyrene     | 276.1             | 137.9     | IS6 | Sur6   | 4                                  | 10 | 20 | 25 | 40 | 50 |    |     | 25                  | 40                 | 2.5   | 5   | 10  | µg/L | 83   | 167 | 333  | µg/Kg |
| Isophorone                 | 82                | 138       | IS2 | Sur3   | 4                                  | 10 | 20 | 25 | 40 | 50 |    |     | 25                  | 40                 | 2.5   | 5   | 10  | µg/L | 83   | 167 | 333  | µg/Kg |
| 1-Methylnaphthalene        | 142               | 141       | IS2 | Sur3   | 4                                  | 10 | 20 | 25 | 40 | 50 |    |     | 25                  | 40                 | 2.5   | 5   | 10  | µg/L | 83   | 167 | 333  | µg/Kg |
| 2-Methylnaphthalene        | 142               | 141       | IS2 | Sur3   | 4                                  | 10 | 20 | 25 | 40 | 50 |    |     | 25                  | 40                 | 2.5   | 5   | 10  | µg/L | 83   | 167 | 333  | µg/Kg |
| 1-Methylphenanthrene       | 192.1             | 165       | IS4 | Sur5   | 4                                  | 10 | 20 | 25 | 40 | 50 |    |     | 25                  | 40                 | 2.5   | 5   | 10  | µg/L | 83   | 167 | 333  | µg/Kg |
| 2-Methylphenol             | 107               | 108       | IS1 | Sur1/2 | 4                                  | 10 | 20 | 25 | 40 | 50 |    |     | 25                  | 40                 | 2.5   | 5   | 10  | µg/L | 83   | 167 | 333  | µg/Kg |
| 4-Methylphenol             | 107               | 108       | IS1 | Sur1/2 | 4                                  | 10 | 20 | 25 | 40 | 50 |    |     | 25                  | 40                 | 2.5   | 5   | 10  | µg/L | 83   | 167 | 333  | µg/Kg |
| Naphthalene                | 128               | 129       | IS2 | Sur3   | 4                                  | 10 | 20 | 25 | 40 | 50 |    |     | 25                  | 40                 | 2.5   | 5   | 10  | µg/L | 83   | 167 | 333  | µg/Kg |
| 2-Nitroaniline             | 65                | 92        | IS3 | Sur4   | 4                                  | 10 | 20 | 25 | 40 | 50 |    |     | 25                  | 40                 | 2.5   | 5   | 10  | µg/L | 83   | 167 | 333  | µg/Kg |
| 3-Nitroaniline             | 138               | 92        | IS3 | Sur4   | 4                                  | 10 | 20 | 25 | 40 | 50 |    |     | 25                  | 40                 | 2.5   | 5   | 10  | µg/L | 83   | 167 | 333  | µg/Kg |
| 4-Nitroaniline             | 138               | 92        | IS3 | Sur4   | 4                                  | 10 | 20 | 25 | 40 | 50 |    |     | 25                  | 40                 | 2.5   | 5   | 10  | µg/L | 120  | 167 | 333  | µg/Kg |
| Nitrobenzene               | 77                | 123       | IS2 | Sur3   | 4                                  | 10 | 20 | 25 | 40 | 50 |    |     | 25                  | 40                 | 2.5   | 5   | 10  | µg/L | 83   | 167 | 333  | µg/Kg |
| 2-Nitrophenol              | 139               | 65        | IS2 | Sur3   | 4                                  | 10 | 20 | 25 | 40 | 50 |    |     | 25                  | 40                 | 2.5   | 5   | 10  | µg/L | 83   | 167 | 333  | µg/Kg |
| 4-Nitrophenol              | 109               | 139       | IS3 | Sur4   | 4                                  | 10 | 20 | 25 | 40 | 50 |    |     | 25                  | 40                 | 2.5   | 5   | 10  | µg/L | 106  | 167 | 667  | µg/Kg |
| N-nitrosodimethylamine     | 74                | 42        | IS1 | Sur1/2 | 4                                  | 10 | 20 | 25 | 40 | 50 |    |     | 25                  | 40                 | 2.5   | 5   | 10  | µg/L | 83   | 167 | 333  | µg/Kg |
| N-Nitroso-di-n-propylamine | 70                | 42        | IS1 | Sur1/2 | 4                                  | 10 | 20 | 25 | 40 | 50 |    |     | 25                  | 40                 | 2.5   | 5   | 10  | µg/L | 83   | 167 | 333  | µg/Kg |
| N-Nitrosodiphenylamine     | 169               | 168       | IS4 | Sur5   | 4                                  | 10 | 20 | 25 | 40 | 50 |    |     | 25                  | 40                 | 2.5   | 5   | 10  | µg/L | 153  | 167 | 333  | µg/Kg |
| Pentachlorophenol          | 265.8             | 164.9     | IS4 | Sur5   | 4                                  | 10 | 20 | 25 | 40 | 50 |    |     | 25                  | 40                 | 2.5   | 5   | 10  | µg/L | 83   | 167 | 667  | µg/Kg |
| Perylene                   | 252.1             | 125       | IS6 | Sur6   | 4                                  | 10 | 20 | 25 | 40 | 50 |    |     | 25                  | 40                 | 2.5   | 5   | 10  | µg/L | 86   | 167 | 333  | µg/Kg |
| Phenanthrene               | 178               | 152       | IS4 | Sur5   | 4                                  | 10 | 20 | 25 | 40 | 50 |    |     | 25                  | 40                 | 2.5   | 5   | 10  | µg/L | 83   | 167 | 333  | µg/Kg |
| Phenol                     | 94                | 65        | IS1 | Sur1/2 | 4                                  | 10 | 20 | 25 | 40 | 50 |    |     | 25                  | 40                 | 2.5   | 5   | 10  | µg/L | 83   | 167 | 333  | µg/Kg |
| Pyrene                     | 202               | 100.9     | IS5 | Sur6   | 4                                  | 10 | 20 | 25 | 40 | 50 |    |     | 25                  | 40                 | 2.5   | 5   | 10  | µg/L | 160  | 167 | 333  | µg/Kg |
| Pyridine                   | 79                | 52        | IS1 | Sur1/2 | 4                                  | 10 | 20 | 25 | 40 | 50 | 80 | 100 | 25                  | 80                 | 11    | 20  | 40  | µg/L | 333  | 667 | 1333 | µg/Kg |
| 2,3,4,6-Tetrachlorophenol  | 231.8             | 229.8     | IS3 | Sur4   | 4                                  | 10 | 20 | 25 | 40 | 50 |    |     | 25                  | 40                 | 3.6   | 5   | 10  | µg/L | 100  | 167 | 333  | µg/Kg |

**Table 8: TYPICAL TARGET ANALYTE LIST**

| Analyte                      | Quantitation Ions |           | IS    | SUR  | ICAL ANALYTE CONCENTRATIONS (µg/L) |    |    |    |    |    |     |   | ICV/DCC<br>EV(µg/L) | LCS/MS<br>EV(µg/L) | WATER |     |      |      | SOIL |     |      |       |
|------------------------------|-------------------|-----------|-------|------|------------------------------------|----|----|----|----|----|-----|---|---------------------|--------------------|-------|-----|------|------|------|-----|------|-------|
|                              | Primary           | Secondary |       |      | 1                                  | 2  | 3  | 4  | 5  | 6  | 7   | 8 |                     |                    | DL    | LOD | LOQ  | Unit | DL   | LOD | LOQ  | Unit  |
| 1,2,4-Trichlorobenzene       | 179.9             | 181.9     | IS2   | Sur3 | 4                                  | 10 | 20 | 25 | 40 | 50 |     |   | 25                  | 40                 | 2.5   | 5   | 10   | µg/L | 83   | 167 | 333  | µg/Kg |
| 2,3,4-Trichlorophenol        | 195.9             | 96.9      | IS3   | Sur4 | 4                                  | 10 | 20 | 25 | 40 | 50 |     |   | 25                  | 40                 | 2.5   | 5   | 10   | µg/L | 83   | 167 | 333  | µg/Kg |
| 2,3,5-Trichlorophenol        | 195.9             | 96.9      | IS3   | Sur4 | 4                                  | 10 | 20 | 25 | 40 | 50 |     |   | 25                  | 40                 | 2.5   | 5   | 10   | µg/L | 165  | 167 | 333  | µg/Kg |
| 2,4,5-Trichlorophenol        | 195.9             | 197.9     | IS3   | Sur4 | 4                                  | 10 | 20 | 25 | 40 | 50 |     |   | 25                  | 40                 | 2.5   | 5   | 10   | µg/L | 91   | 167 | 333  | µg/Kg |
| 2,4,6-Trichlorophenol        | 195.9             | 197.9     | IS3   | Sur4 | 4                                  | 10 | 20 | 25 | 40 | 50 |     |   | 25                  | 40                 | 2.5   | 5   | 10   | µg/L | 83   | 167 | 333  | µg/Kg |
| 2,3,5-Trimethylnaphthalene   | 171.1             | 155       | IS3   | Sur4 | 4                                  | 10 | 20 | 25 | 40 | 50 |     |   | 25                  | 40                 | 2.5   | 5   | 10   | µg/L | 83   | 167 | 333  | µg/Kg |
| Benzidine                    | 184               | 92        | IS1/4 | Sur5 | 4                                  | 10 | 25 | 40 | 50 | 80 | 100 |   | 25                  | 80                 | 10    | 20  | 50   | µg/L | 863  | 867 | 1333 | µg/Kg |
| 2-Fluorophenol (Sur1)        | 112               | 64        | IS1   |      | 4                                  | 10 | 20 | 25 | 40 | 50 |     |   | 25                  | 40                 | 1.5   | 3   | 5    | µg/L | 61   | 100 | 167  | µg/Kg |
| Phenol-d5 (Sur2)             | 99                | 71        | IS1   |      | 4                                  | 10 | 20 | 25 | 40 | 50 |     |   | 25                  | 40                 | 1.5   | 3   | 5    | µg/L | 52   | 100 | 167  | µg/Kg |
| Nitrobenzene-d5 (Sur3)       | 82                | 128       | IS2   |      | 4                                  | 10 | 20 | 25 | 40 | 50 |     |   | 25                  | 40                 | 0.59  | 1   | 1.67 | µg/L | 17   | 33  | 56   | µg/Kg |
| 2-Fluorobiphenyl (Sur4)      | 172               | 171       | IS3   |      | 4                                  | 10 | 20 | 25 | 40 | 50 |     |   | 25                  | 40                 | 0.5   | 1   | 1.67 | µg/L | 24   | 33  | 56   | µg/Kg |
| 2,4,6-Tribromophenol (Sur5)  | 329.8             | 331.8     | IS4   |      | 4                                  | 10 | 20 | 25 | 40 | 50 |     |   | 25                  | 40                 | 1.5   | 3   | 5    | µg/L | 55   | 100 | 167  | µg/Kg |
| Terphenyl-d14 (Sur6)         | 244.2             | 122       | IS5   |      | 4                                  | 10 | 20 | 25 | 40 | 50 |     |   | 25                  | 40                 | 0.54  | 1   | 1.67 | µg/L | 24   | 33  | 56   | µg/Kg |
| 1,4-Dichlorobenzene-d4 (IS1) | 151.9             | 115       |       |      |                                    |    |    |    |    |    |     |   |                     |                    |       |     |      |      |      |     |      |       |
| Naphtalene-d8 (IS2)          | 136               | 68        |       |      |                                    |    |    |    |    |    |     |   |                     |                    |       |     |      |      |      |     |      |       |
| Acenaphthene-d10 (IS3)       | 164.1             | 162.1     |       |      |                                    |    |    |    |    |    |     |   |                     |                    |       |     |      |      |      |     |      |       |
| Phenanthrene-d10 (IS4)       | 188.1             | 94        |       |      |                                    |    |    |    |    |    |     |   |                     |                    |       |     |      |      |      |     |      |       |
| Chrysene-d12 (IS5)           | 240.1             | 120       |       |      |                                    |    |    |    |    |    |     |   |                     |                    |       |     |      |      |      |     |      |       |
| Perylene-d12 (IS6)           | 264.1             | 130       |       |      |                                    |    |    |    |    |    |     |   |                     |                    |       |     |      |      |      |     |      |       |

\*Dissociated to 1,2-Diphenylhydrazine

**Table 9: TYPICAL TARGET ANALYTE LIST FOR APPENDIX IX**

| Appendix IX Compound          | Quantitation Ions |           | IS  | SUR    | ICAL ANALYTE CONCENTRATIONS (µg/L) |    |    |    |    |    |    | ICV/DCC<br>EV(µg/L) | LCS/MS<br>EV(µg/L) | WATER |     |     |      | SOIL |     |     |       |
|-------------------------------|-------------------|-----------|-----|--------|------------------------------------|----|----|----|----|----|----|---------------------|--------------------|-------|-----|-----|------|------|-----|-----|-------|
|                               | Primary           | Secondary |     |        | 1                                  | 2  | 3  | 4  | 5  | 6  | 7  |                     |                    | DL    | LOD | LOQ | Unit | DL   | LOD | LOQ | Unit  |
| a,a-dimethylphenethylamine    | 58                | 91        | IS2 | Sur3   | 4                                  | 10 | 20 | 25 | 30 | 40 | 50 | 25                  | 40                 | 13    | 20  | 40  | µg/L | NA   | NA  | NA  | µg/Kg |
| Acetophenone                  | 77                | 120       | IS2 | Sur3   | 4                                  | 10 | 20 | 25 | 30 | 40 | 50 | 25                  | 40                 | 2.5   | 5   | 10  | µg/L | 83   | 167 | 333 | µg/Kg |
| 2-Acetylaminofluorene         | 181               | 223.1     | IS6 | Sur6   | 4                                  | 10 | 20 | 25 | 30 | 40 | 50 | 25                  | 40                 | 2.7   | 5   | 10  | µg/L | 83   | 167 | 333 | µg/Kg |
| 4-Aminobiphenyl               | 169               | 115       | IS4 | Sur5   | 4                                  | 10 | 20 | 25 | 30 | 40 | 50 | 25                  | 40                 | 2.5   | 5   | 10  | µg/L | 85   | 167 | 333 | µg/Kg |
| Aramite                       | 184.9             | 62.9      | IS5 | Sur6   | 4                                  | 10 | 20 | 25 | 30 | 40 | 50 | 25                  | 40                 | 2.5   | 5   | 10  | µg/L | 83   | 167 | 333 | µg/Kg |
| Atrazine                      | 200               | 215       | IS4 | Sur5   | 4                                  | 10 | 20 | 25 | 30 | 40 | 50 | 25                  | 40                 | 2.5   | 5   | 10  | µg/L | 83   | 167 | 333 | µg/Kg |
| Biphenyl                      | 154               | 76        | IS3 | Sur4   | 4                                  | 10 | 20 | 25 | 30 | 40 | 50 | 25                  | 40                 | 2.5   | 5   | 10  | µg/L | 83   | 167 | 333 | µg/Kg |
| Chlorobenzilate               | 251               | 138.9     | IS5 | Sur6   | 4                                  | 10 | 20 | 25 | 30 | 40 | 50 | 25                  | 40                 | 2.5   | 5   | 10  | µg/L | 83   | 167 | 333 | µg/Kg |
| 1-Chloronaphthalene           | 162               | 127       | IS3 | Sur4   | 4                                  | 10 | 20 | 25 | 30 | 40 | 50 | 25                  | 40                 | 2.5   | 5   | 10  | µg/L | 83   | 167 | 333 | µg/Kg |
| Diallate                      | 86                | 234       | IS4 | Sur5   | 4                                  | 10 | 20 | 25 | 30 | 40 | 50 | 25                  | 40                 | 2.5   | 5   | 10  | µg/L | 100  | 167 | 333 | µg/Kg |
| Dibenzo(a,j)acridine          | 279.1             | 139.3     | IS6 | Sur6   | 4                                  | 10 | 20 | 25 | 30 | 40 | 50 | 25                  | 40                 | 2.5   | 5   | 10  | µg/L | 83   | 167 | 333 | µg/Kg |
| 2,6-Dichlorophenol            | 161.9             | 63        | IS2 | Sur3   | 4                                  | 10 | 20 | 25 | 30 | 40 | 50 | 25                  | 40                 | 2.5   | 5   | 10  | µg/L | 83   | 167 | 333 | µg/Kg |
| Dimethoate                    | 86.9              | 124.9     | IS4 | Sur5   | 4                                  | 10 | 20 | 25 | 30 | 40 | 50 | 25                  | 40                 | 3     | 5   | 10  | µg/L | 89   | 167 | 333 | µg/Kg |
| p-Dimethylaminoazobenzene     | 120               | 225.1     | IS5 | Sur6   | 4                                  | 10 | 20 | 25 | 30 | 40 | 50 | 25                  | 40                 | 2.5   | 5   | 10  | µg/L | 83   | 167 | 333 | µg/Kg |
| 7,12-Dimethylben(a)anthracene | 256.1             | 241.1     | IS6 | Sur6   | 4                                  | 10 | 20 | 25 | 30 | 40 | 50 | 25                  | 40                 | 2.5   | 5   | 10  | µg/L | 83   | 167 | 333 | µg/Kg |
| 3,3-Dimethylbenzidine         | 212.1             | 196       | IS5 | Sur6   | 4                                  | 10 | 20 | 25 | 30 | 40 | 50 | 25                  | 40                 | 5     | 10  | 20  | µg/L | 130  | 167 | 667 | µg/Kg |
| 3,4-Dimethylphenol            | 107               | 122       | IS2 | Sur3   | 4                                  | 10 | 20 | 25 | 30 | 40 | 50 | 25                  | 40                 | 2.5   | 5   | 10  | µg/L | 83   | 167 | 333 | µg/Kg |
| 1,3-Dinitrobenzene            | 167.9             | 75.9      | IS3 | Sur4   | 4                                  | 10 | 20 | 25 | 30 | 40 | 50 | 25                  | 40                 | 2.5   | 5   | 10  | µg/L | 83   | 167 | 333 | µg/Kg |
| Dinoseb                       | 211               | 162.9     | IS4 | Sur5   | 4                                  | 10 | 20 | 25 | 30 | 40 | 50 | 25                  | 40                 | 2.5   | 5   | 10  | µg/L | 83   | 167 | 333 | µg/Kg |
| 1,4-Dioxane                   | 88                | 57.9      | IS1 | Sur1/2 | 4                                  | 10 | 20 | 25 | 30 | 40 | 50 | 25                  | 40                 | 2.5   | 5   | 10  | µg/L | 83   | 167 | 333 | µg/Kg |
| Diphenyl ether                | 170               | 141       | IS3 | Sur4   | 4                                  | 10 | 20 | 25 | 30 | 40 | 50 | 25                  | 40                 | 2.5   | 5   | 10  | µg/L | 83   | 167 | 333 | µg/Kg |
| Disulfoton                    | 88                | 96.9      | IS4 | Sur5   | 4                                  | 10 | 20 | 25 | 30 | 40 | 50 | 25                  | 40                 | 2.5   | 5   | 10  | µg/L | 83   | 167 | 333 | µg/Kg |
| Ethyl methacrylate            | 69                | 41        | IS1 | Sur1/2 | 4                                  | 10 | 20 | 25 | 30 | 40 | 50 | 25                  | 40                 | 2.5   | 5   | 10  | µg/L | 83   | 167 | 333 | µg/Kg |
| Ethyl methanesulfonate        | 78.9              | 108.9     | IS1 | Sur1/2 | 4                                  | 10 | 20 | 25 | 30 | 40 | 50 | 25                  | 40                 | 2.5   | 5   | 10  | µg/L | 83   | 167 | 333 | µg/Kg |
| Ethyl parathion               | 96.9              | 108.9     | IS5 | Sur6   | 4                                  | 10 | 20 | 25 | 30 | 40 | 50 | 25                  | 40                 | 2.5   | 5   | 10  | µg/L | 83   | 167 | 333 | µg/Kg |
| Hexachloropropene             | 212.8             | 140.8     | IS2 | Sur3   | 4                                  | 10 | 20 | 25 | 30 | 40 | 50 | 25                  | 40                 | 2.5   | 5   | 10  | µg/L | 83   | 167 | 333 | µg/Kg |
| Isodrin                       | 192.9             | 262.8     | IS5 | Sur6   | 4                                  | 10 | 20 | 25 | 30 | 40 | 50 | 25                  | 40                 | 2.5   | 5   | 10  | µg/L | 83   | 167 | 333 | µg/Kg |
| Isosafrole                    | 162               | 104       | IS3 | Sur4   | 4                                  | 10 | 20 | 25 | 30 | 40 | 50 | 25                  | 40                 | 2.5   | 5   | 10  | µg/L | 83   | 167 | 333 | µg/Kg |
| Methapyrilene                 | 58                | 96.9      | IS5 | Sur6   | 4                                  | 10 | 20 | 25 | 30 | 40 | 50 | 25                  | 40                 | 10    | 20  | 40  | µg/L | NA   | NA  | NA  | µg/Kg |
| 3-Methylcholanthrene          | 268.1             | 252.1     | IS6 | Sur6   | 4                                  | 10 | 20 | 25 | 30 | 40 | 50 | 25                  | 40                 | 2.5   | 5   | 10  | µg/L | 83   | 167 | 333 | µg/Kg |
| Methyl methanesulfonate       | 79.9              | 78.9      | IS1 | Sur1/2 | 4                                  | 10 | 20 | 25 | 30 | 40 | 50 | 25                  | 40                 | 2.5   | 5   | 10  | µg/L | 83   | 167 | 333 | µg/Kg |
| Methyl parathion              | 108.9             | 263       | IS5 | Sur6   | 4                                  | 10 | 20 | 25 | 30 | 40 | 50 | 25                  | 40                 | 2.5   | 5   | 10  | µg/L | 83   | 167 | 333 | µg/Kg |
| 1,4-Naphthoquinone            | 158               | 130       | IS3 | Sur4   | 4                                  | 10 | 20 | 25 | 30 | 40 | 50 | 25                  | 40                 | 2.5   | 5   | 10  | µg/L | 83   | 167 | 333 | µg/Kg |
| 1-Naphthylamine               | 143               | 115       | IS3 | Sur4   | 4                                  | 10 | 20 | 25 | 30 | 40 | 50 | 25                  | 40                 | 2.5   | 5   | 10  | µg/L | 83   | 167 | 333 | µg/Kg |
| 2-Naphthylamine               | 143               | 115       | IS3 | Sur4   | 4                                  | 10 | 20 | 25 | 30 | 40 | 50 | 25                  | 40                 | 10    | 10  | 20  | µg/L | 330  | 333 | 667 | µg/Kg |
| N-nitrosodiethylamine         | 102               | 56        | IS1 | Sur1/2 | 4                                  | 10 | 20 | 25 | 30 | 40 | 50 | 25                  | 40                 | 2.5   | 5   | 10  | µg/L | 83   | 167 | 333 | µg/Kg |
| N-nitrosomethylethylamine     | 88                | 42        | IS1 | Sur1/2 | 4                                  | 10 | 20 | 25 | 30 | 40 | 50 | 25                  | 40                 | 2.5   | 5   | 10  | µg/L | 83   | 167 | 333 | µg/Kg |



**Table 10: CALIBRATION CHECK COMPOUNDS (CCCs)**

---

| <b>Base/Neutral Fraction</b> | <b>Acid Fraction</b>    |
|------------------------------|-------------------------|
| Acenaphthene                 | 4-Chloro-3-methylphenol |
| 1,4-Dichlorobenzene          | 2,4-Dichlorophenol      |
| Hexachlorobutadine           | 2-Nitrophenol           |
| N-Nitrosodiphenylamine       | Phenol                  |
| Di-n-octylphthalate          | Pentachlorophenol       |
| Fluoranthene                 | 2,4,6-Trichlorophenol   |
| Benzo(a)pyrene               |                         |

**Table 11: SYSTEM PERFORMANCE CALIBRATION CHECK COMPOUNDS (SPCCs)**

---

| <b>Base/Neutral Compounds</b> | <b>Acid Compounds</b> |
|-------------------------------|-----------------------|
| N-Nitroso-di-n-propylamine    | 2,4-Dinitrophenol     |
| Hexachlorocyclopentadiene     | 4-Nitrophenol         |



**Figure 1:** **PEAK EVALUATION TECHNIQUE**

---

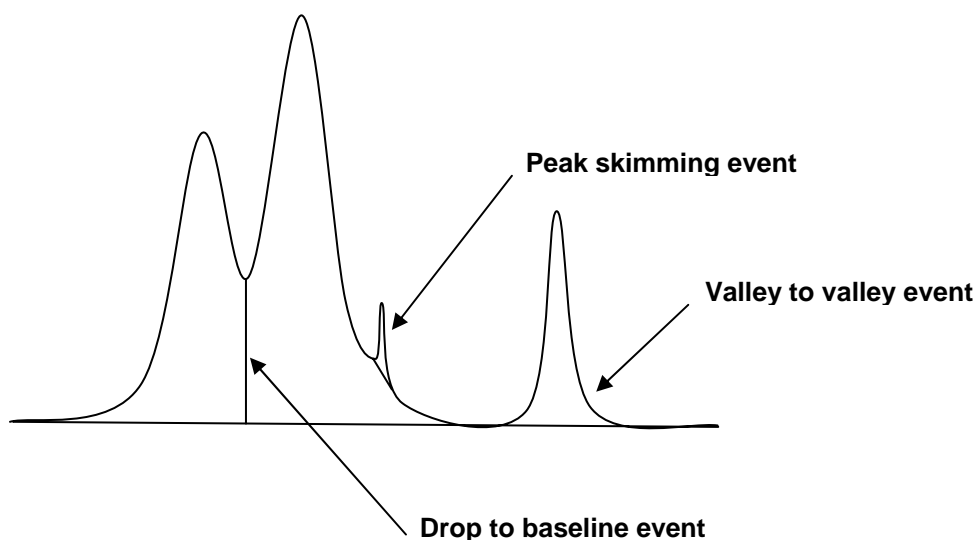
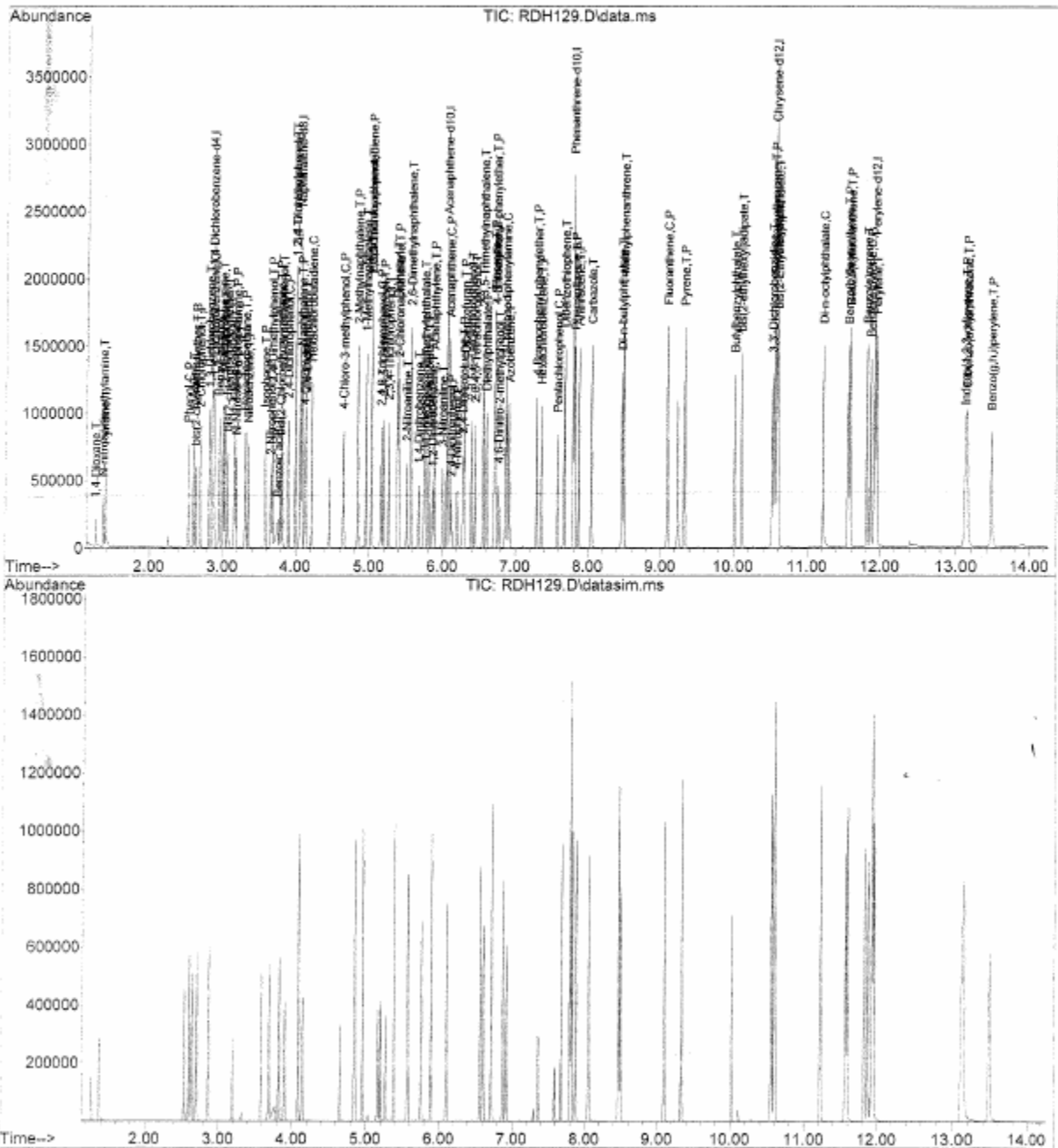

Figure 2: TYPICAL CHROMATOGRAM

Quantitation Report (QT Reviewed)  
Data File : D:\DATA\14D10\RDH129.D Vial: 16  
Acq On : 10 Apr 2014 20:01 Operator: KV  
Sample : ISVE7D101 Inst : E7  
Misc : ICV Multiplr: 1.00  
Integrator: RTE  
Quant Time: Apr 11 11:46:25 2014  
Quant Results File: SVE7D10.RES  
Quant Method : C:\msdchem\1\METHODS\SVE7D10.M  
Quant Title : SEMIVOLATILES  
QLast Update : Thu Apr 10 18:33:28 2014  
Response via : Initial Calibration  
DataAcq Meth: SVE7D10S.M



**Figure 2A: TYPICAL CHROMATOGRAM FOR BENZIDINE**

Quantitation Report (QT Reviewed)  
Data File : D:\DATA\14D10\RDH137.D Vial: 24  
Acq On : 10 Apr 2014 22:36 Operator: KV  
Sample : ISVE7D10A1 Inst : E7  
Misc : ICV Multiplr: 1.00  
Integrator: RTE  
Quant Time: Apr 11 11:57:29 2014  
Quant Results File: SVE7D10A.RES  
Quant Method : C:\msdchem\1\METHODS\SVE7D10A.M  
Quant Title : Semivolatiles - Benzidine  
QLast Update : Fri Apr 11 11:56:02 2014  
Response via : Initial Calibration  
DataAcq Meth:SVE7D10S.M

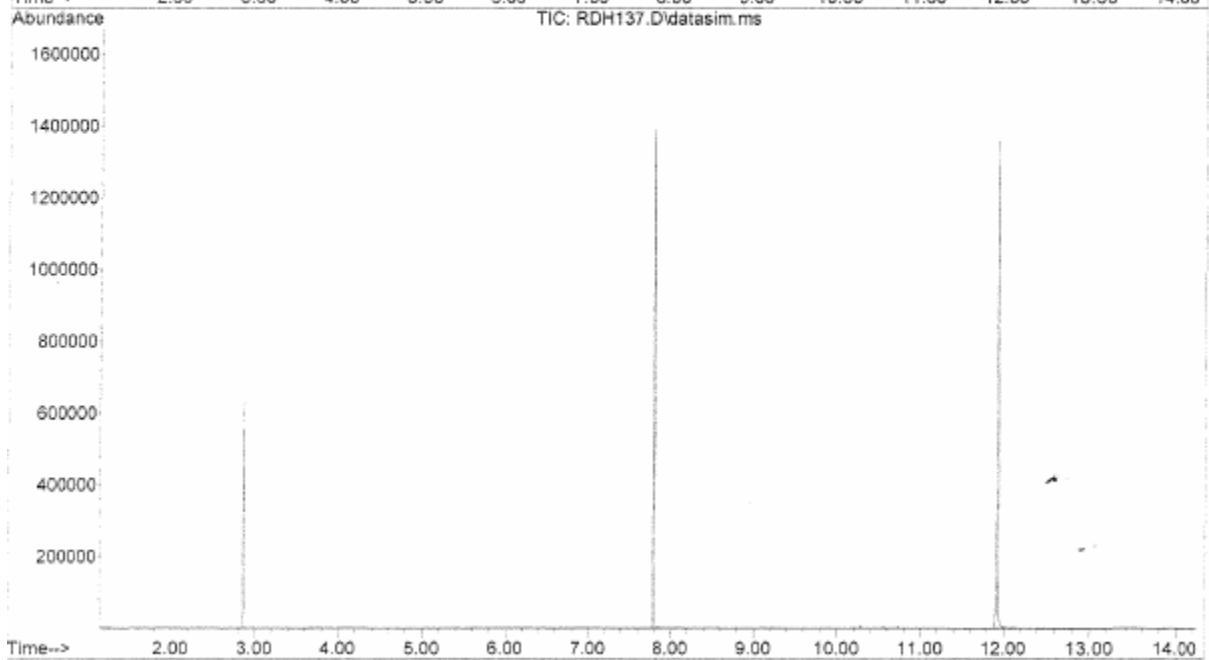
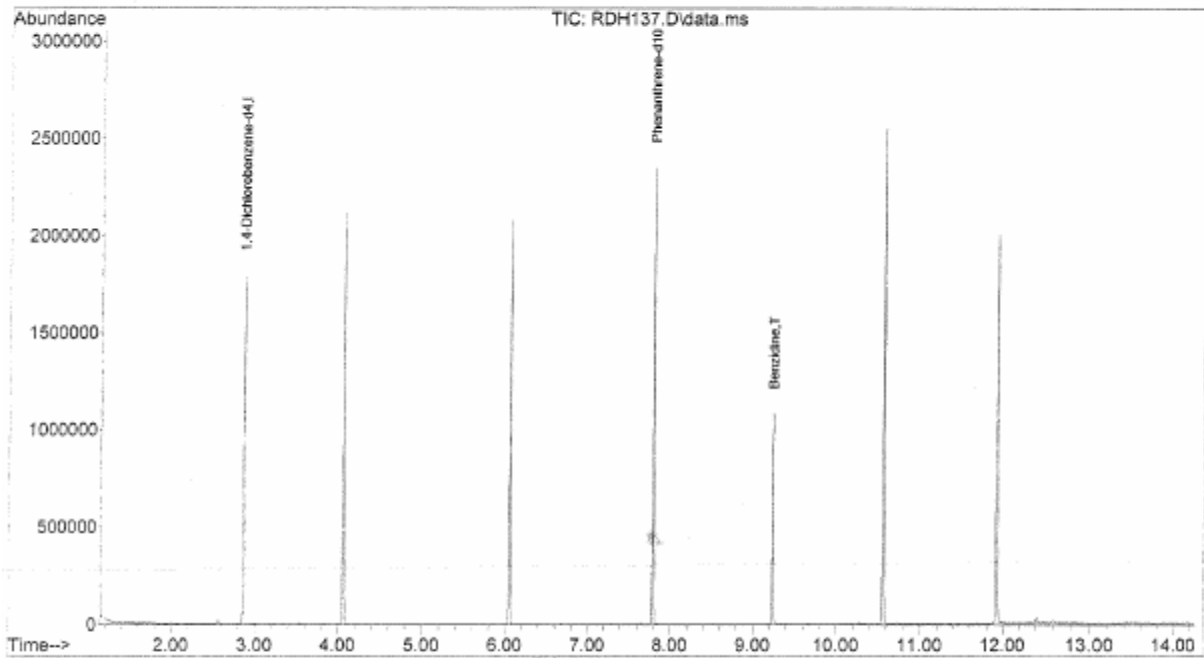



**Figure 2B (cont.): TYPICAL CHROMATOGRAM FOR APPENDIX IX**

Quantitation Report (QT Reviewed)  
Data File : D:\DATA\14D11\RDH155.D Vial: 10  
Acq On : 11 Apr 2014 17:10 Operator: DJ  
Sample : ISVE7D11C1 Inst : E7  
Misc : 50PPM Multiplr: 1.00  
Integrator: RTE  
Quant Time: Apr 11 17:33:29 2014  
Quant Results File: SVE7D11C.RES  
Quant Method : C:\msdchem\1\METHODS\SVE7D11C.M  
Quant Title : SEMIVOLATILES APP9  
QLast Update : Fri Apr 11 17:30:55 2014  
Response via : Initial Calibration  
DataAcq Meth:SVE7D10S.M

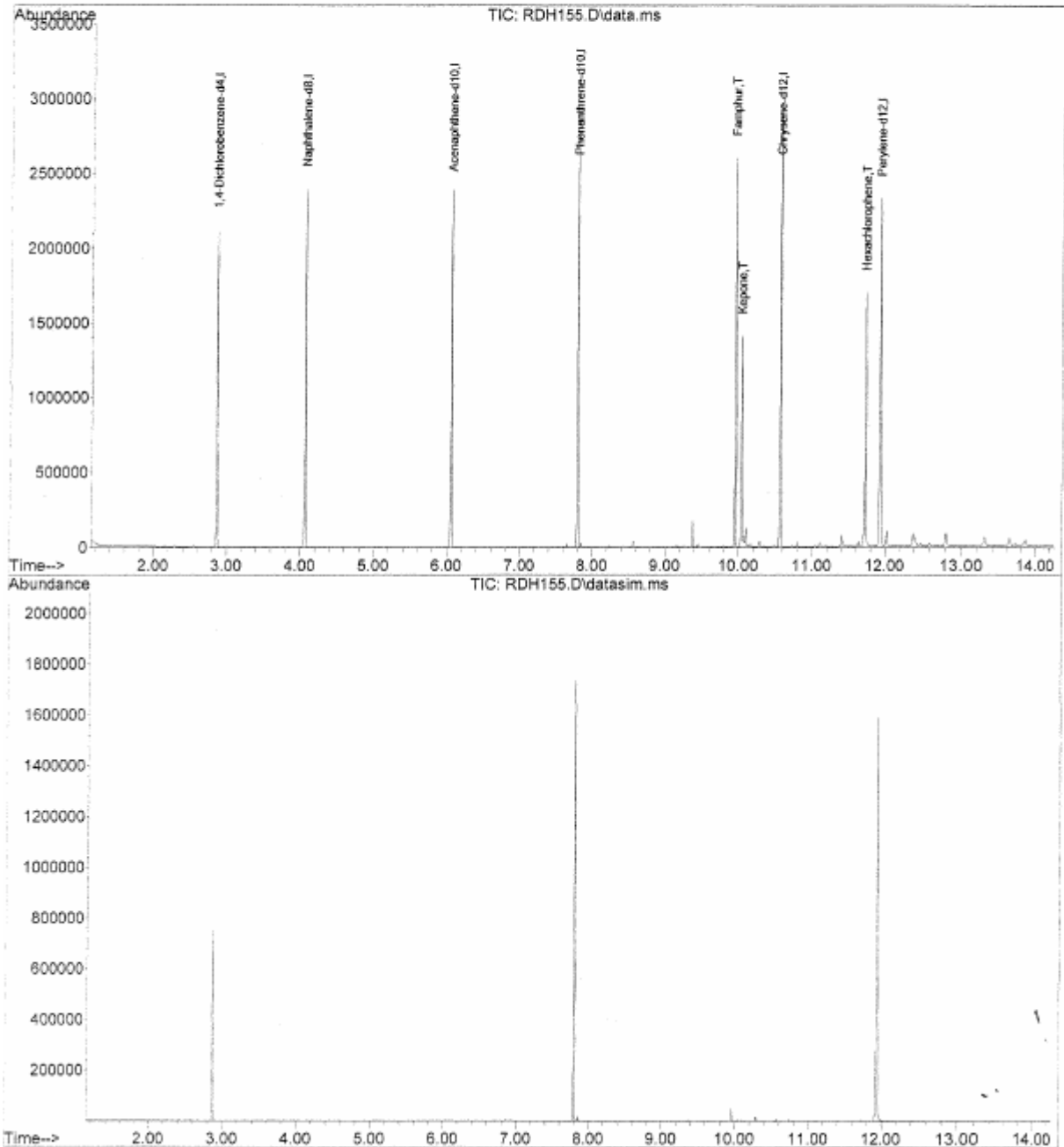

**Figure 3: TYPICAL ICAL SUMMARY**

INITIAL\_CALIBRATION - RELATIVE\_RESPONSE\_FACTOR

Instrument ID :E4  
Beginning Date/Time :02/18/14 11:45  
Spike Units :PPM  
IC File :RBJ065

Column Spec :Rxi-5SilMS ID :0.18MM  
Ending Date/Time :02/18/14 14:01  
HPCChem Method :SVE4B18

| IDX | Parameters                  | 4               | 10              | 20              | 25              | 40              | 50              | 80              | 100             | Av_RRF | %_RSD | Av_Rt_M |
|-----|-----------------------------|-----------------|-----------------|-----------------|-----------------|-----------------|-----------------|-----------------|-----------------|--------|-------|---------|
|     |                             | 14:01<br>RBJ068 | 13:41<br>RBJ067 | 13:22<br>RBJ066 | 13:03<br>RBJ065 | 12:43<br>RBJ064 | 12:24<br>RBJ063 | 12:05<br>RBJ062 | 11:45<br>RBJ061 |        |       |         |
| 1   | 1,4-Dichlorobenzene-d4      | 1               | 1               | 1               | 1               | 1               | 1               | 1               | 1               | 1      | 0     | 3.0245  |
| 2   | 1,4-Dioxane                 | 0.509           | 0.390           | 0.448           | 0.428           | 0.413           | 0.414           | -----           | -----           | 0.434  | 9.62  | 1.3713  |
| 3   | N-nitrosodimethylamine      | 0.599           | 0.596           | 0.620           | 0.603           | 0.589           | 0.581           | -----           | -----           | 0.598  | 2.24  | 1.4806  |
| 4   | Pyridine                    | 1.163           | 1.093           | 1.184           | 1.121           | 1.110           | 1.102           | 1.158           | 1.125           | 1.132  | 2.90  | 1.5077  |
| 5   | 2-Fluorophenol              | 1.029           | 0.973           | 1.053           | 1.029           | 1.008           | 1.004           | -----           | -----           | 1.016  | 2.68  | 2.0861  |
| 6   | Phenol-d5                   | 1.212           | 1.238           | 1.333           | 1.311           | 1.294           | 1.275           | -----           | -----           | 1.277  | 3.55  | 2.6749  |
| 7   | Phenol                      | 1.312           | 1.303           | 1.394           | 1.360           | 1.341           | 1.342           | -----           | -----           | 1.342  | 2.46  | 2.6871  |
| 8   | Aniline                     | 1.681           | 1.642           | 1.768           | 1.712           | 1.718           | 1.699           | -----           | -----           | 1.704  | 2.47  | 2.7514  |
| 9   | bis(2-chloroethyl)ether     | 0.986           | 0.951           | 1.015           | 0.998           | 0.951           | 0.972           | -----           | -----           | 0.979  | 2.64  | 2.7749  |
| 10  | 2-Chlorophenol              | 1.166           | 1.154           | 1.226           | 1.168           | 1.179           | 1.173           | -----           | -----           | 1.178  | 2.14  | 2.8513  |
| 11  | 1,3-Dichlorobenzene         | 1.413           | 1.394           | 1.460           | 1.416           | 1.364           | 1.379           | -----           | -----           | 1.404  | 2.40  | 2.9813  |
| 12  | 1,2-Dichlorobenzene-d4      | 0.890           | 0.888           | 0.916           | 0.897           | 0.883           | 0.875           | -----           | -----           | 0.892  | 1.58  | 3.1621  |
| 13  | 1,4-Dichlorobenzene         | 1.439           | 1.423           | 1.507           | 1.441           | 1.423           | 1.413           | -----           | -----           | 1.441  | 2.37  | 3.0389  |
| 14  | Benzyl alcohol              | 0.703           | 0.707           | 0.774           | 0.763           | 0.753           | 0.749           | -----           | -----           | 0.742  | 3.99  | 3.1157  |
| 15  | 1,2-Dichlorobenzene         | 1.354           | 1.308           | 1.406           | 1.379           | 1.352           | 1.356           | -----           | -----           | 1.359  | 2.38  | 3.1749  |
| 16  | 2-Methylphenol              | 0.876           | 0.905           | 0.976           | 0.953           | 0.948           | 0.941           | -----           | -----           | 0.933  | 3.90  | 3.1957  |
| 17  | bis(2-chloroisopropyl)ether | 1.904           | 1.877           | 1.989           | 1.909           | 1.875           | 1.822           | -----           | -----           | 1.896  | 2.89  | 3.2341  |
| 18  | 4-Methylphenol              | 1.172           | 1.167           | 1.223           | 1.226           | 1.209           | 1.183           | -----           | -----           | 1.197  | 2.17  | 3.3364  |
| 19  | N-Nitroso-di-n-propylamine  | 0.768           | 0.766           | 0.833           | 0.817           | 0.798           | 0.769           | -----           | -----           | 0.792  | 3.60  | 3.3563  |
| 20  | Hexachloroethane            | 0.529           | 0.548           | 0.591           | 0.565           | 0.564           | 0.555           | -----           | -----           | 0.559  | 3.69  | 3.4872  |
| 21  | Naphthalene-d8              | 1               | 1               | 1               | 1               | 1               | 1               | 1               | 1               | 1      | 0     | 4.2527  |
| 22  | Nitrobenzene-d5             | 0.421           | 0.423           | 0.454           | 0.397           | 0.388           | 0.387           | -----           | -----           | 0.412  | 6.35  | 3.5128  |
| 23  | Nitrobenzene                | 0.374           | 0.378           | 0.411           | 0.396           | 0.396           | 0.396           | -----           | -----           | 0.392  | 3.46  | 3.5303  |
| 24  | Isophorone                  | 0.608           | 0.615           | 0.656           | 0.707           | 0.707           | 0.717           | -----           | -----           | 0.668  | 7.34  | 3.7598  |
| 25  | 2-Nitrophenol               | 0.168           | 0.169           | 0.186           | 0.176           | 0.179           | 0.180           | -----           | -----           | 0.176  | 3.80  | 3.8445  |
| 26  | 2,4-Dimethylphenol          | 0.368           | 0.368           | 0.395           | 0.376           | 0.377           | 0.379           | -----           | -----           | 0.377  | 2.66  | 3.8637  |
| 27  | Benzoic acid                | 0.121           | 0.195           | 0.238           | 0.234           | 0.240           | 0.274           | 0.253           | 0.253           | 0.226  | 21.27 | 3.9613  |
| 28  | bis(2-Chloroethoxy)methane  | 0.350           | 0.359           | 0.378           | 0.357           | 0.367           | 0.368           | -----           | -----           | 0.363  | 2.77  | 3.9643  |
| 29  | 3,5-Dimethylphenol          | 0.360           | 0.423           | 0.448           | 0.427           | 0.437           | 0.437           | -----           | -----           | 0.422  | 7.45  | 4.0026  |
| 30  | 2,4-Dichlorophenol          | 0.308           | 0.309           | 0.338           | 0.329           | 0.324           | 0.327           | -----           | -----           | 0.322  | 3.68  | 4.0860  |
| 31  | 3,4-Dimethylphenol          | 0.438           | 0.444           | 0.484           | 0.465           | 0.471           | 0.480           | -----           | -----           | 0.464  | 4.03  | 4.1817  |
| 32  | 1,2,4-Trichlorobenzene      | 0.401           | 0.387           | 0.416           | 0.403           | 0.405           | 0.408           | -----           | -----           | 0.403  | 2.32  | 4.1873  |
| 33  | Naphthalene                 | 0.948           | 0.958           | 1.031           | 0.986           | 0.985           | 1.002           | -----           | -----           | 0.985  | 3.04  | 4.2742  |
| 34  | 4-Chloroaniline             | 0.388           | 0.396           | 0.439           | 0.413           | 0.415           | 0.419           | -----           | -----           | 0.412  | 4.36  | 4.3169  |
| 35  | 2,6-Dichlorophenol          | 0.306           | 0.299           | 0.328           | 0.316           | 0.318           | 0.322           | -----           | -----           | 0.315  | 3.37  | 4.3305  |
| 36  | Hexachlorobutadiene         | 0.283           | 0.286           | 0.297           | 0.283           | 0.290           | 0.291           | -----           | -----           | 0.288  | 1.93  | 4.4118  |
| 37  | Hydroquinone                | -----           | -----           | -----           | -----           | -----           | -----           | -----           | -----           | 0.000  | 0.00  | 0.0000  |
| 38  | 4-Chloro-3-methylphenol     | 0.261           | 0.283           | 0.307           | 0.301           | 0.299           | 0.299           | -----           | -----           | 0.292  | 5.80  | 4.8467  |
| 39  | 2-Methylnaphthalene         | 0.661           | 0.659           | 0.707           | 0.678           | 0.684           | 0.695           | -----           | -----           | 0.680  | 2.81  | 5.0423  |
| 40  | 1-Methylnaphthalene         | 0.614           | 0.607           | 0.648           | 0.632           | 0.630           | 0.636           | -----           | -----           | 0.628  | 2.38  | 5.1573  |
| 41  | Acenaphthene-d10            | 1               | 1               | 1               | 1               | 1               | 1               | 1               | 1               | 1      | 0     | 6.2772  |
| 42  | Hexachlorocyclopentadiene   | 0.518           | 0.512           | 0.573           | 0.529           | 0.553           | 0.569           | -----           | -----           | 0.542  | 4.83  | 5.2364  |
| 43  | 2,3,5-Trichlorophenol       | 0.312           | 0.332           | 0.371           | 0.392           | 0.370           | 0.421           | -----           | -----           | 0.366  | 10.81 | 5.2356  |
| 44  | 2,4,6-Trichlorophenol       | 0.412           | 0.424           | 0.463           | 0.434           | 0.446           | 0.449           | -----           | -----           | 0.438  | 4.19  | 5.3654  |
| 45  | 2,4,5-Trichlorophenol       | 0.418           | 0.430           | 0.471           | 0.452           | 0.469           | 0.468           | -----           | -----           | 0.451  | 4.99  | 5.4033  |
| 46  | 2-Fluorobiphenyl            | 1.449           | 1.468           | 1.566           | 1.696           | 1.526           | 1.795           | -----           | -----           | 1.583  | 8.58  | 5.4693  |
| 47  | 2,3,4-Trichlorophenol       | 0.422           | 0.420           | 0.447           | 0.429           | 0.460           | 0.447           | -----           | -----           | 0.437  | 3.69  | 5.4789  |
| 48  | Biphenyl                    | 1.390           | 1.403           | 1.543           | 1.433           | 1.464           | 1.497           | -----           | -----           | 1.455  | 4.02  | 5.5870  |
| 49  | 2-Chloronaphthalene         | 1.131           | 1.156           | 1.243           | 1.170           | 1.173           | 1.202           | -----           | -----           | 1.179  | 3.29  | 5.6102  |
| 50  | 2-Nitroaniline              | 0.310           | 0.332           | 0.366           | 0.341           | 0.345           | 0.352           | -----           | -----           | 0.341  | 5.56  | 5.7229  |
| 51  | 2,6-Dimethylnaphthalene     | 0.993           | 1.054           | 1.109           | 1.045           | 1.063           | 1.095           | -----           | -----           | 1.060  | 3.88  | 5.7741  |
| 52  | 1,4-Dinitrobenzene          | 0.132           | 0.151           | 0.173           | 0.165           | 0.166           | 0.167           | -----           | -----           | 0.159  | 9.39  | 5.8772  |
| 53  | Dimethylphthalate           | 1.511           | 1.509           | 1.646           | 1.511           | 1.483           | 1.511           | -----           | -----           | 1.528  | 3.82  | 5.9517  |
| 54  | 1,3-Dinitrobenzene          | 0.168           | 0.180           | 0.197           | 0.186           | 0.188           | 0.194           | -----           | -----           | 0.185  | 5.64  | 5.9726  |
| 55  | 2,6-Dinitrotoluene          | 0.249           | 0.265           | 0.284           | 0.271           | 0.274           | 0.272           | -----           | -----           | 0.269  | 4.34  | 6.0144  |

Figure 3 (cont.): TYPICAL ICAL SUMMARY

|     |                            |       |       |       |       |       |       |       |       |       |       |         |
|-----|----------------------------|-------|-------|-------|-------|-------|-------|-------|-------|-------|-------|---------|
| 56  | 1,2-Dinitrobenzene         | 0.102 | 0.112 | 0.120 | 0.112 | 0.112 | 0.116 | ----- | ----- | 0.113 | 5.35  | 6.0771  |
| 57  | Acenaphthylene             | 1.692 | 1.729 | 1.881 | 1.770 | 1.788 | 1.812 | ----- | ----- | 1.779 | 3.70  | 6.1053  |
| 58  | 3-Nitroaniline             | 0.245 | 0.265 | 0.281 | 0.267 | 0.268 | 0.274 | ----- | ----- | 0.267 | 4.63  | 6.2152  |
| 59  | Acenaphthene               | 1.156 | 1.143 | 1.234 | 1.155 | 1.184 | 1.195 | ----- | ----- | 1.178 | 2.85  | 6.3167  |
| 60  | 2,4-Dinitrophenol          | 0.130 | 0.156 | 0.186 | 0.175 | 0.189 | 0.192 | ----- | ----- | 0.172 | 14.10 | 6.3366  |
| 61  | 4-Nitrophenol              | 0.203 | 0.228 | 0.253 | 0.230 | 0.243 | 0.248 | ----- | ----- | 0.234 | 7.77  | 6.4165  |
| 62  | 2,4-Dinitrotoluene         | 0.327 | 0.363 | 0.393 | 0.364 | 0.363 | 0.370 | ----- | ----- | 0.363 | 5.78  | 6.5004  |
| 63  | Dibenzofuran               | 1.588 | 1.632 | 1.740 | 1.637 | 1.672 | 1.678 | ----- | ----- | 1.658 | 3.11  | 6.5228  |
| 64  | 2,3,5,6-Tetrachlorophenol  | 0.287 | 0.307 | 0.329 | 0.306 | 0.323 | 0.326 | ----- | ----- | 0.313 | 5.12  | 6.6194  |
| 65  | 2,3,4,6-Tetrachlorophenol  | 0.345 | 0.374 | 0.405 | 0.370 | 0.422 | 0.441 | ----- | ----- | 0.393 | 9.19  | 6.6722  |
| 66  | 2,3,5-Trimethylnaphthalene | 0.966 | 0.968 | 1.046 | 0.988 | 1.007 | 1.034 | ----- | ----- | 1.002 | 3.35  | 6.7808  |
| 67  | Diethylphthalate           | 1.323 | 1.323 | 1.422 | 1.337 | 1.356 | 1.380 | ----- | ----- | 1.357 | 2.84  | 6.8074  |
| 68  | Fluorene                   | 1.302 | 1.310 | 1.422 | 1.355 | 1.396 | 1.439 | ----- | ----- | 1.370 | 4.20  | 6.9356  |
| 69  | 4-Chlorophenyl-phenylether | 0.714 | 0.720 | 0.778 | 0.732 | 0.746 | 0.772 | ----- | ----- | 0.744 | 3.61  | 6.9379  |
| 70  | 4-Nitroaniline             | 0.244 | 0.262 | 0.290 | 0.262 | 0.273 | 0.276 | ----- | ----- | 0.268 | 5.87  | 6.9535  |
| 71  | Phenanthrene-d10           | 1     | 1     | 1     | 1     | 1     | 1     | 1     | 1     | 1     | 0     | 8.0159  |
| 72  | 4,6-Dinitro-2-methylphenol | 0.097 | 0.123 | 0.140 | 0.131 | 0.135 | 0.132 | ----- | ----- | 0.126 | 12.28 | 6.9926  |
| 73  | N-Nitrosodiphenylamine     | 0.608 | 0.578 | 0.546 | 0.523 | 0.524 | 0.568 | ----- | ----- | 0.558 | 5.95  | 7.0767  |
| 74  | Azobenzene                 | 0.598 | 0.577 | 0.628 | 0.603 | 0.595 | 0.593 | ----- | ----- | 0.599 | 2.79  | 7.1258  |
| 75  | 2,4,6-Tribromophenol       | 0.092 | 0.093 | 0.105 | 0.097 | 0.098 | 0.099 | ----- | ----- | 0.097 | 4.74  | 7.2191  |
| 76  | 4-Bromophenyl-phenylether  | 0.207 | 0.203 | 0.215 | 0.204 | 0.206 | 0.203 | ----- | ----- | 0.207 | 2.23  | 7.5094  |
| 77  | Hexachlorobenzene          | 0.228 | 0.213 | 0.228 | 0.222 | 0.218 | 0.214 | ----- | ----- | 0.221 | 3.11  | 7.5889  |
| 78  | Pentachlorophenol          | 0.124 | 0.140 | 0.151 | 0.143 | 0.145 | 0.146 | ----- | ----- | 0.142 | 6.58  | 7.8061  |
| 79  | Dibenzothiofene            | 0.884 | 0.882 | 0.945 | 0.987 | 0.887 | 1.005 | ----- | ----- | 0.932 | 5.95  | 7.8997  |
| 80  | Phenanthrene               | 0.976 | 0.966 | 1.021 | 0.981 | 0.970 | 0.972 | ----- | ----- | 0.981 | 2.07  | 8.0419  |
| 81  | Dinoseb                    | ----- | ----- | ----- | ----- | ----- | ----- | ----- | ----- | 0.000 | 0.00  | 0.0000  |
| 82  | Anthracene                 | 0.981 | 0.979 | 1.040 | 0.993 | 0.995 | 0.993 | ----- | ----- | 0.997 | 2.21  | 8.0975  |
| 83  | Carbazole                  | 0.836 | 0.846 | 0.895 | 0.833 | 0.839 | 0.841 | ----- | ----- | 0.848 | 2.75  | 8.2730  |
| 84  | Di-n-butylphthalate        | 1.012 | 1.030 | 1.122 | 1.050 | 1.059 | 1.068 | ----- | ----- | 1.057 | 3.57  | 8.6639  |
| 85  | 1-Methylphenanthrene       | 0.714 | 0.715 | 0.777 | 0.727 | 0.726 | 0.731 | ----- | ----- | 0.732 | 3.17  | 8.7171  |
| 86  | Fluoranthene               | 1.111 | 1.163 | 1.244 | 1.173 | 1.182 | 1.202 | ----- | ----- | 1.179 | 3.72  | 9.3297  |
| 87  | Chrysene-d12               | 1     | 1     | 1     | 1     | 1     | 1     | 1     | 1     | 1     | 0     | 10.8160 |
| 88  | Benzdine                   | ----- | ----- | ----- | ----- | ----- | ----- | ----- | ----- | 0.000 | 0.00  | 0.0000  |
| 89  | Pyrene                     | 1.059 | 1.039 | 1.100 | 1.051 | 1.041 | 1.028 | ----- | ----- | 1.053 | 2.40  | 9.5665  |
| 90  | Terphenyl-d14              | 0.719 | 0.701 | 0.750 | 0.703 | 0.705 | 0.692 | ----- | ----- | 0.712 | 2.91  | 9.7277  |
| 91  | Butylbenzylphthalate       | 0.361 | 0.377 | 0.422 | 0.392 | 0.392 | 0.391 | ----- | ----- | 0.389 | 5.21  | 10.2291 |
| 92  | bis(2-ethylhexyl)adipate   | 0.282 | 0.290 | 0.317 | 0.299 | 0.301 | 0.292 | ----- | ----- | 0.297 | 4.08  | 10.3082 |
| 93  | 3,3'-Dichlorobenzidine     | 0.323 | 0.348 | 0.362 | 0.346 | 0.347 | 0.347 | ----- | ----- | 0.346 | 3.58  | 10.7722 |
| 94  | Benzo(a)anthracene         | 1.035 | 1.013 | 1.072 | 1.012 | 1.024 | 1.021 | ----- | ----- | 1.029 | 2.18  | 10.8022 |
| 95  | Chrysene                   | 0.931 | 0.928 | 0.965 | 0.918 | 0.918 | 0.908 | ----- | ----- | 0.928 | 2.14  | 10.8419 |
| 96  | bis(2-Ethylhexyl)phthalate | 0.602 | 0.616 | 0.669 | 0.639 | 0.632 | 0.630 | ----- | ----- | 0.631 | 3.57  | 10.8127 |
| 97  | Perylene-d12               | 1     | 1     | 1     | 1     | 1     | 1     | 1     | 1     | 1     | 0     | 12.2554 |
| 98  | Di-n-octylphthalate        | 0.969 | 1.019 | 1.179 | 1.084 | 1.117 | 1.135 | ----- | ----- | 1.084 | 7.19  | 11.4319 |
| 99  | Benzo(b)fluoranthene       | 0.990 | 1.002 | 1.130 | 1.005 | 1.068 | 1.105 | ----- | ----- | 1.050 | 5.64  | 11.8473 |
| 100 | Benzo(k)fluoranthene       | 0.966 | 0.989 | 1.067 | 1.056 | 1.010 | 1.014 | ----- | ----- | 1.017 | 3.81  | 11.8754 |
| 101 | Benzo(e)pyrene             | 0.933 | 0.917 | 1.033 | 0.953 | 0.965 | 0.983 | ----- | ----- | 0.964 | 4.26  | 12.1343 |
| 102 | Benzo(a)pyrene             | 0.923 | 0.946 | 1.040 | 0.973 | 0.990 | 1.005 | ----- | ----- | 0.980 | 4.25  | 12.1910 |
| 103 | Perylene                   | 0.995 | 0.986 | 1.050 | 0.980 | 0.984 | 1.001 | ----- | ----- | 0.999 | 2.60  | 12.2849 |
| 104 | Indeno(1,2,3-cd)pyrene     | 1.069 | 1.070 | 1.202 | 1.112 | 1.146 | 1.172 | ----- | ----- | 1.129 | 4.83  | 13.5858 |
| 105 | Dibenzo(a,h)anthracene     | 0.858 | 0.897 | 0.995 | 0.925 | 0.956 | 0.981 | ----- | ----- | 0.935 | 5.58  | 13.5980 |
| 106 | Benzo(g,h,i)perylene       | 0.898 | 0.908 | 0.989 | 0.941 | 0.930 | 0.950 | ----- | ----- | 0.936 | 3.48  | 13.9846 |

Ave\_%RSD : 4.5 Max\_%RSD : 21.3

Use Least Square Linear Regression with weighting factor of inverse concentration  
Resp\_Ratio = x0 + x1 \* Amt\_Ratio

| IDX | Parameter    | x0       | x1      | CCF    |
|-----|--------------|----------|---------|--------|
| 27  | Benzoic acid | -0.01462 | 0.26295 | 0.9988 |

**Figure 3A: TYPICAL ICAL SUMMARY OF BENZIDINE**

INITIAL\_CALIBRATION - RELATIVE\_RESPONSE\_FACTOR

Instrument ID :E4  
 Beginning DateTime :02/18/14 09:10  
 Spike Units :PPM  
 IC File :RBJ057

Column Spec :Rxi-5Si1MS ID :0.18MM  
 Ending DateTime :02/18/14 11:07  
 HPCHEM Method :SVE4B18A

| IDX | Parameters             | 4               | 10              | 25              | 40              | 50              | 80              | 100             | Av_RRF | %_RSD | Av_Rt_M |
|-----|------------------------|-----------------|-----------------|-----------------|-----------------|-----------------|-----------------|-----------------|--------|-------|---------|
|     |                        | 11:07<br>RBJ059 | 10:47<br>RBJ058 | 10:28<br>RBJ057 | 10:09<br>RBJ056 | 09:49<br>RBJ055 | 09:30<br>RBJ054 | 09:10<br>RBJ053 |        |       |         |
| 1   | 1,4-Dichlorobenzene-d4 | 1               | 1               | 1               | 1               | 1               | 1               | 1               | 1      | 0     | 3.0246  |
| 2   | Benzaldehyde           | -----           | -----           | -----           | -----           | -----           | -----           | -----           | 0.000  | 0.00  | 0.0000  |
| 3   | Caprolactam            | -----           | -----           | -----           | -----           | -----           | -----           | -----           | 0.000  | 0.00  | 0.0000  |
| 4   | Phenanthrene-d10       | 1               | 1               | 1               | 1               | 1               | 1               | 1               | 1      | 0     | 8.0143  |
| 5   | Benzidine              | 0.585           | 0.692           | 0.774           | 0.775           | 0.778           | 0.785           | 0.820           | 0.744  | 10.77 | 9.4674  |

Ave\_%RSD : 10.8

Max\_%RSD : 10.8



**Figure 3B: TYPICAL ICAL SUMMARY OF APPENDIX IX**

INITIAL\_CALIBRATION - RELATIVE\_RESPONSE\_FACTOR

Instrument ID :E4  
Beginning Date/Time :02/18/14 16:27  
Spike Units :PPM  
IC File :RBJ078

Column Spec :Rxi-5SilMS ID :0.18MM  
Ending Date/Time :02/18/14 18:43  
HPChem Method :SVE4B18B

| IDX | Parameters                      | 4               | 10              | 20              | 25              | 30              | 40              | 50              | Av_RRF | %_RSD | Av_Rt_M |
|-----|---------------------------------|-----------------|-----------------|-----------------|-----------------|-----------------|-----------------|-----------------|--------|-------|---------|
|     |                                 | 18:43<br>RBJ081 | 18:24<br>RBJ080 | 18:05<br>RBJ079 | 17:26<br>RBJ078 | 17:07<br>RBJ077 | 16:47<br>RBJ076 | 16:27<br>RBJ075 |        |       |         |
| 1   | 1,4-Dichlorobenzene-d4          | 1               | 1               | 1               | 1               | 1               | 1               | 1               | 1      | 0     | 3.0246  |
| 2   | 1,4-Dioxane                     | 0.465           | 0.420           | 0.478           | 0.471           | 0.479           | 0.469           | 0.476           | 0.465  | 4.39  | 1.3713  |
| 3   | Ethyl methacrylate              | 0.887           | 0.901           | 0.938           | 0.908           | 0.915           | 0.907           | 0.926           | 0.912  | 1.82  | 1.6489  |
| 4   | 2-Picoline                      | 1.242           | 1.210           | 1.266           | 1.222           | 1.242           | 1.242           | 1.239           | 1.238  | 1.43  | 1.8165  |
| 5   | N-nitrosomethyl ethylamine      | 0.480           | 0.475           | 0.469           | 0.460           | 0.473           | 0.459           | 0.458           | 0.468  | 1.92  | 1.8507  |
| 6   | Methyl methanesulfonate         | 0.794           | 0.912           | 0.941           | 0.908           | 0.926           | 0.894           | 0.899           | 0.896  | 5.33  | 1.9942  |
| 7   | 2-Fluorophenol                  | 1.113           | 1.068           | 1.111           | 1.072           | 1.088           | 1.092           | 1.094           | 1.091  | 1.57  | 2.0894  |
| 8   | N-nitrosodiethylamine           | 0.433           | 0.459           | 0.484           | 0.473           | 0.484           | 0.479           | 0.486           | 0.471  | 4.09  | 2.2339  |
| 9   | Ethyl methanesulfonate          | 0.937           | 0.889           | 0.937           | 0.904           | 0.908           | 0.921           | 0.913           | 0.916  | 1.92  | 2.4017  |
| 10  | Phenol-d5                       | 1.416           | 1.333           | 1.398           | 1.399           | 1.414           | 1.404           | 1.413           | 1.397  | 2.08  | 2.6748  |
| 11  | Benzaldehyde                    | -----           | -----           | -----           | -----           | -----           | -----           | -----           | 0.000  | 0.00  | 0.0000  |
| 12  | Pentachloroethane               | 0.595           | 0.635           | 0.648           | 0.616           | 0.633           | 0.623           | 0.633           | 0.626  | 2.73  | 2.7992  |
| 13  | 1,2-Dichlorobenzene-d4          | 0.998           | 0.990           | 1.035           | 0.983           | 1.005           | 1.019           | 1.030           | 1.009  | 1.97  | 3.1638  |
| 14  | N-nitrosopyrrolidine            | 0.392           | 0.420           | 0.480           | 0.456           | 0.469           | 0.469           | 0.454           | 0.449  | 6.99  | 3.3351  |
| 15  | Naphthalene-d8                  | 1               | 1               | 1               | 1               | 1               | 1               | 1               | 1      | 0     | 4.2541  |
| 16  | Acetophenone                    | 0.446           | 0.435           | 0.448           | 0.441           | 0.448           | 0.444           | 0.451           | 0.445  | 1.22  | 3.3645  |
| 17  | N-nitrosomorpholine             | 0.237           | 0.236           | 0.248           | 0.246           | 0.248           | 0.247           | 0.247           | 0.244  | 2.18  | 3.3652  |
| 18  | o-toluidine                     | 0.537           | 0.608           | 0.547           | 0.616           | 0.552           | 0.633           | 0.637           | 0.590  | 7.34  | 3.3994  |
| 19  | Nitrobenzene-d5                 | 0.462           | 0.453           | 0.468           | 0.467           | 0.480           | 0.477           | 0.472           | 0.468  | 1.98  | 3.5123  |
| 20  | N-nitrosopiperidine             | 0.158           | 0.147           | 0.156           | 0.152           | 0.157           | 0.157           | 0.155           | 0.155  | 2.38  | 3.6706  |
| 21  | O,O,O-triethyl phosphorothioate | 0.153           | 0.151           | 0.157           | 0.156           | 0.157           | 0.161           | 0.164           | 0.157  | 2.77  | 3.9336  |
| 22  | a,a-dimethylphenethylamine      | 1.090           | 1.043           | 1.050           | 1.030           | 1.006           | 0.982           | 0.914           | 1.016  | 5.58  | 4.1700  |
| 23  | 3,4-Dimethylphenol              | -----           | -----           | -----           | -----           | -----           | -----           | -----           | 0.000  | 0.00  | 0.0000  |
| 24  | 2,6-Dichlorophenol              | -----           | -----           | -----           | -----           | -----           | -----           | -----           | 0.000  | 0.00  | 0.0000  |
| 25  | Hexachloropropene               | 0.355           | 0.356           | 0.377           | 0.374           | 0.381           | 0.380           | 0.383           | 0.372  | 3.17  | 4.3755  |
| 26  | Hydroquinone                    | -----           | -----           | -----           | -----           | -----           | -----           | -----           | 0.000  | 0.00  | 0.0000  |
| 27  | N-nitrosodi-n-butylamine        | 0.237           | 0.228           | 0.303           | 0.292           | 0.285           | 0.289           | 0.285           | 0.274  | 10.65 | 4.6892  |
| 28  | p-phenylenediamine              | 0.279           | 0.338           | 0.300           | 0.290           | 0.290           | 0.267           | 0.256           | 0.289  | 9.17  | 4.6988  |
| 29  | epsilon-Caprolactam             | -----           | -----           | -----           | -----           | -----           | -----           | -----           | 0.000  | 0.00  | 0.0000  |
| 30  | Safrole                         | 0.298           | 0.292           | 0.304           | 0.301           | 0.302           | 0.306           | 0.356           | 0.309  | 6.95  | 4.9365  |
| 31  | 1-Methylnaphthalene             | -----           | -----           | -----           | -----           | -----           | -----           | -----           | 0.000  | 0.00  | 0.0000  |
| 32  | 1,2,4,5-Tetrachlorobenzene      | 0.476           | 0.459           | 0.485           | 0.482           | 0.489           | 0.492           | 0.491           | 0.482  | 2.41  | 5.2417  |
| 33  | Acenaphthene-d10                | 1               | 1               | 1               | 1               | 1               | 1               | 1               | 1      | 0     | 6.2771  |
| 34  | 2-Fluorobiphenyl                | 1.709           | 1.687           | 1.768           | 1.689           | 1.994           | 1.998           | 2.024           | 1.838  | 8.63  | 5.4710  |
| 35  | Isosafrole                      | 0.530           | 0.491           | 0.517           | 0.498           | 0.509           | 0.518           | 0.519           | 0.512  | 2.61  | 5.5453  |
| 36  | Biphenyl                        | -----           | -----           | -----           | -----           | -----           | -----           | -----           | 0.000  | 0.00  | 0.0000  |
| 37  | 1-Chloronaphthalene             | 1.168           | 1.140           | 1.184           | 1.159           | 1.184           | 1.192           | 1.203           | 1.176  | 1.81  | 5.6397  |
| 38  | Diphenyl ether                  | 0.832           | 0.954           | 0.866           | 0.847           | 0.843           | 0.852           | 0.865           | 0.866  | 4.74  | 5.7124  |
| 39  | 1,4-Naphthoquinone              | 0.402           | 0.429           | 0.403           | 0.373           | 0.347           | 0.322           | 0.316           | 0.370  | 11.79 | 5.8083  |
| 40  | 1,3-Dinitrobenzene              | -----           | -----           | -----           | -----           | -----           | -----           | -----           | 0.000  | 0.00  | 0.0000  |
| 41  | Pentachlorobenzene              | 0.647           | 0.630           | 0.635           | 0.638           | 0.652           | 0.654           | 0.657           | 0.645  | 1.61  | 6.4818  |
| 42  | 1-Naphthylamine                 | 1.047           | 1.127           | 1.104           | 1.066           | 1.099           | 1.104           | 1.110           | 1.094  | 2.52  | 6.6099  |
| 43  | 2,3,4,6-Tetrachlorophenol       | -----           | -----           | -----           | -----           | -----           | -----           | -----           | 0.000  | 0.00  | 0.0000  |
| 44  | 2-Naphthylamine                 | 1.248           | 1.277           | 1.200           | 1.153           | 1.174           | 1.187           | 1.198           | 1.205  | 3.56  | 6.7064  |
| 45  | Thionazin                       | 0.177           | 0.185           | 0.183           | 0.181           | 0.184           | 0.184           | 0.183           | 0.183  | 1.38  | 6.8995  |
| 46  | 5-Nitro-o-toluidine             | 0.279           | 0.339           | 0.320           | 0.317           | 0.326           | 0.320           | 0.327           | 0.318  | 5.89  | 6.9438  |
| 47  | Phenanthrene-d10                | 1               | 1               | 1               | 1               | 1               | 1               | 1               | 1      | 0     | 8.0190  |
| 48  | 2,4,6-Tribromophenol            | 0.092           | 0.095           | 0.100           | 0.099           | 0.104           | 0.100           | 0.101           | 0.099  | 3.94  | 7.2173  |
| 49  | Sulfotepp                       | 0.077           | 0.076           | 0.084           | 0.084           | 0.084           | 0.085           | 0.084           | 0.082  | 4.54  | 7.2756  |
| 50  | 1,3,5-Trinitrobenzene           | 0.049           | 0.055           | 0.060           | 0.061           | 0.066           | 0.061           | 0.063           | 0.059  | 9.19  | 7.3744  |

**Figure 3B (cont.): TYPICAL ICAL SUMMARY OF APPENDIX IX**

|    |                               |       |       |       |       |       |       |       |       |       |         |
|----|-------------------------------|-------|-------|-------|-------|-------|-------|-------|-------|-------|---------|
| 51 | Phorate                       | 0.325 | 0.315 | 0.351 | 0.345 | 0.348 | 0.343 | 0.348 | 0.339 | 4.02  | 7.4303  |
| 52 | Phenacetin                    | 0.298 | 0.303 | 0.299 | 0.297 | 0.318 | 0.296 | 0.306 | 0.302 | 2.52  | 7.4439  |
| 53 | Diallate                      | 0.037 | 0.027 | 0.029 | 0.027 | 0.027 | 0.026 | 0.026 | 0.028 | 13.80 | 7.5241  |
| 54 | Dimethoate                    | 0.182 | 0.181 | 0.174 | 0.172 | 0.175 | 0.164 | 0.165 | 0.173 | 4.10  | 7.6166  |
| 55 | Atrazine                      | 0.208 | 0.194 | 0.187 | 0.176 | 0.164 | 0.155 | 0.148 | 0.176 | 12.33 | 7.7029  |
| 56 | Pentachloronitrobenzene       | 0.126 | 0.116 | 0.123 | 0.121 | 0.120 | 0.119 | 0.119 | 0.121 | 2.70  | 7.8304  |
| 57 | 4-Aminobiphenyl               | 0.681 | 0.658 | 0.642 | 0.632 | 0.639 | 0.608 | 0.613 | 0.639 | 3.96  | 7.8061  |
| 58 | Pronamide                     | 0.319 | 0.328 | 0.338 | 0.333 | 0.364 | 0.330 | 0.333 | 0.335 | 4.19  | 7.8851  |
| 59 | Dinoseb                       | 0.157 | 0.179 | 0.198 | 0.202 | 0.206 | 0.201 | 0.206 | 0.193 | 9.49  | 8.0217  |
| 60 | Disulfoton                    | 0.377 | 0.317 | 0.305 | 0.304 | 0.300 | 0.292 | 0.292 | 0.312 | 9.55  | 8.0231  |
| 61 | Chrysene-d12                  | 1     | 1     | 1     | 1     | 1     | 1     | 1     | 1     | 0     | 10.8113 |
| 62 | Methyl parathion              | 0.153 | 0.160 | 0.175 | 0.170 | 0.166 | 0.167 | 0.160 | 0.164 | 4.35  | 8.4320  |
| 63 | Ethyl parathion               | 0.105 | 0.115 | 0.128 | 0.126 | 0.124 | 0.131 | 0.125 | 0.122 | 7.52  | 8.8524  |
| 64 | 4-Nitroquinoline-N-oxide      | 0.044 | 0.048 | 0.057 | 0.057 | 0.058 | 0.059 | 0.057 | 0.054 | 10.89 | 8.8759  |
| 65 | Methapyrilene                 | 0.318 | 0.317 | 0.296 | 0.277 | 0.265 | 0.253 | 0.239 | 0.281 | 11.07 | 8.9719  |
| 66 | Isodrin                       | 0.122 | 0.110 | 0.126 | 0.124 | 0.116 | 0.128 | 0.120 | 0.121 | 5.04  | 9.1741  |
| 67 | Terphenyl-d14                 | 0.754 | 0.750 | 0.786 | 0.795 | 0.798 | 0.820 | 0.818 | 0.789 | 3.53  | 9.7271  |
| 68 | Aramite                       | 0.049 | 0.055 | 0.063 | 0.061 | 0.061 | 0.060 | 0.059 | 0.058 | 8.11  | 9.7813  |
| 69 | p-Dimethylaminoazobenzene     | 0.200 | 0.220 | 0.234 | 0.226 | 0.231 | 0.236 | 0.233 | 0.226 | 5.52  | 9.8725  |
| 70 | Chlorobenzilate               | 0.273 | 0.274 | 0.294 | 0.282 | 0.284 | 0.297 | 0.291 | 0.285 | 3.32  | 9.9216  |
| 71 | Famphur                       | ----- | ----- | ----- | ----- | ----- | ----- | ----- | 0.000 | 0.00  | 0.0000  |
| 72 | 3,3-Dimethylbenzidine         | 0.241 | 0.226 | 0.224 | 0.215 | 0.211 | 0.205 | 0.201 | 0.218 | 6.31  | 10.2143 |
| 73 | Kepone                        | ----- | ----- | ----- | ----- | ----- | ----- | ----- | 0.000 | 0.00  | 0.0000  |
| 74 | Perylene-d12                  | 1     | 1     | 1     | 1     | 1     | 1     | 1     | 1     | 0     | 12.2513 |
| 75 | 2-Acetylaminofluorene         | 0.386 | 0.434 | 0.462 | 0.472 | 0.472 | 0.467 | 0.468 | 0.452 | 7.07  | 10.4753 |
| 76 | 7,12-Dimethylben(a)anthracene | 0.446 | 0.461 | 0.491 | 0.493 | 0.492 | 0.486 | 0.492 | 0.480 | 3.93  | 11.8314 |
| 77 | 3-Methylcholanthrene          | 0.477 | 0.500 | 0.516 | 0.524 | 0.522 | 0.507 | 0.525 | 0.510 | 3.38  | 12.5691 |
| 78 | Dibenzo(a,j)acridine          | 0.765 | 0.794 | 0.836 | 0.844 | 0.845 | 0.838 | 0.855 | 0.825 | 3.99  | 13.3122 |

Ave\_%RSD : 5                      Max\_%RSD : 13.8

**Figure 3C: TYPICAL ICAL SUMMARY OF ADDITIONAL ANALYTES APPENDIX IX**

INITIAL\_CALIBRATION - RELATIVE\_RESPONSE\_FACTOR

Instrument ID :E4  
 Beginning DateTime :02/18/14 19:31  
 Spike Units :PPM  
 IC File :RBJ088

Column Spec :Rxi-5Si1MS ID :0.18MM  
 Ending DateTime :02/18/14 21:28  
 HPCChem Method :SVE4B18C

| IDX | Parameters             | 20              | 40              | 50              | 80              | 100             | 120             | 140             | Av_RRF | %_RSD | Av_Rt_M |
|-----|------------------------|-----------------|-----------------|-----------------|-----------------|-----------------|-----------------|-----------------|--------|-------|---------|
|     |                        | 21:28<br>RBJ090 | 21:08<br>RBJ089 | 20:49<br>RBJ088 | 20:30<br>RBJ087 | 20:10<br>RBJ086 | 19:51<br>RBJ085 | 19:31<br>RBJ084 |        |       |         |
| 1   | 1,4-Dichlorobenzene-d4 | 1               | 1               | 1               | 1               | 1               | 1               | 1               | 1      | 0     | 3.0246  |
| 2   | Naphthalene-d8         | 1               | 1               | 1               | 1               | 1               | 1               | 1               | 1      | 0     | 4.2506  |
| 3   | Acenaphthene-d10       | 1               | 1               | 1               | 1               | 1               | 1               | 1               | 1      | 0     | 6.2736  |
| 4   | Phenanthrene-d10       | 1               | 1               | 1               | 1               | 1               | 1               | 1               | 1      | 0     | 8.0130  |
| 5   | Chrysene-d12           | 1               | 1               | 1               | 1               | 1               | 1               | 1               | 1      | 0     | 10.8083 |
| 6   | Famphur                | 0.496           | 0.484           | 0.498           | 0.522           | 0.523           | 0.531           | 0.526           | 0.511  | 3.55  | 10.1741 |
| 7   | Kepone                 | 0.096           | 0.094           | 0.101           | 0.105           | 0.104           | 0.104           | 0.106           | 0.101  | 4.57  | 10.2749 |
| 8   | Perylene-d12           | 1               | 1               | 1               | 1               | 1               | 1               | 1               | 1      | 0     | 12.2447 |
| 9   | Hexachlorophene        | 0.042           | 0.060           | 0.069           | 0.084           | 0.083           | 0.085           | 0.088           | 0.073  | 23.28 | 12.0069 |

Ave\_%RSD : 10.5                      Max\_%RSD : 23.3

Use Least Square Linear Regression with weighting factor of inverse concentration  
 Resp\_Ratio = x0 + x1 \* Amt\_Ratio

| IDX | Parameter       | x0       | x1      | CCF    |
|-----|-----------------|----------|---------|--------|
| 9   | Hexachlorophene | -0.02952 | 0.09531 | 0.9991 |

**Figure 4: TYPICAL DFTPP TUNE SUMMARY FOR 8270C**

DFTPP

Data Path : D:\DATA\14D10\  
 Data File : RDH115.D  
 Acq On : 10 Apr 2014 15:20  
 Operator : KV  
 Sample : DFTE7D1001  
 Misc :  
 ALS Vial : 2 Sample Multiplier: 1

Integration File: rteint.p

Method : C:\msdchem\1\METHODS\DFTPP.M  
 Title : DFTPP  
 Last Update : Thu Apr 10 18:47:54 2014

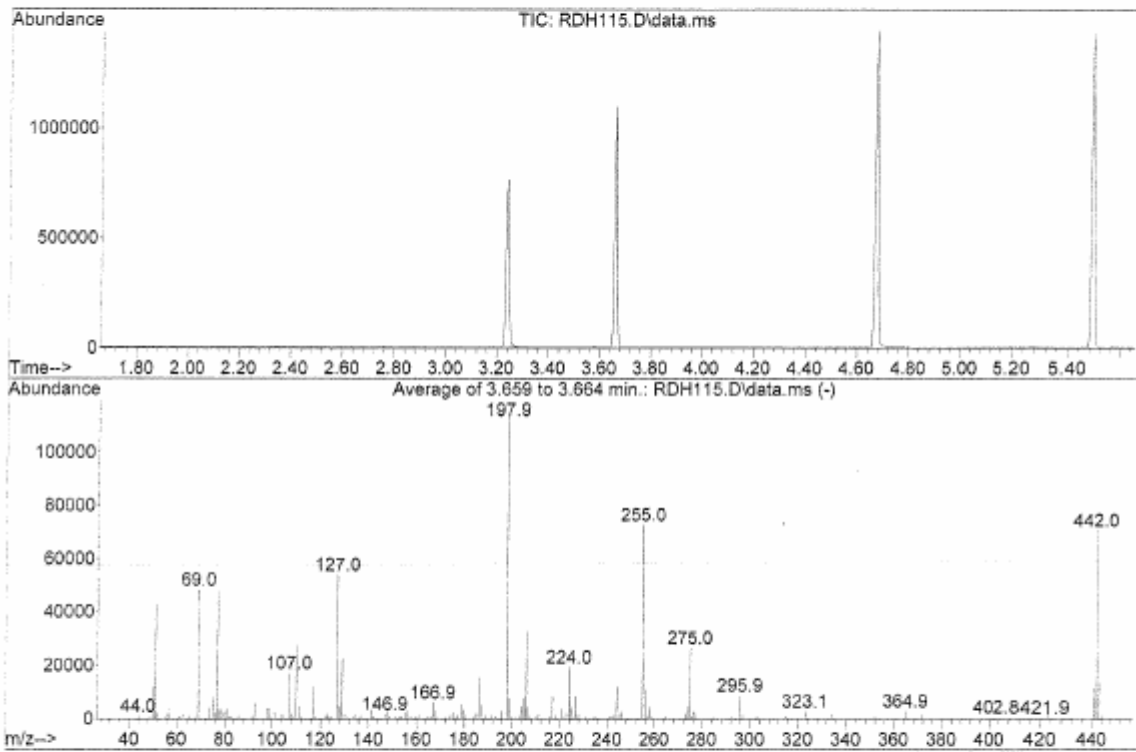

AutoFind: Scans 736, 737, 738; Background Corrected with Scan 728

| Target Mass | Rel. to Mass | Lower Limit% | Upper Limit% | Rel. Abn% | Raw Abn | Result Pass/Fail |
|-------------|--------------|--------------|--------------|-----------|---------|------------------|
| 51          | 198          | 30           | 60           | 37.6      | 42960   | PASS             |
| 68          | 69           | 0.00         | 2            | 0.9       | 440     | PASS             |
| 69          | 198          | 0.00         | 100          | 42.3      | 48224   | PASS             |
| 70          | 69           | 0.00         | 2            | 0.0       | 0       | PASS             |
| 127         | 198          | 40           | 60           | 47.1      | 53784   | PASS             |
| 197         | 198          | 0.00         | 1            | 0.0       | 0       | PASS             |
| 198         | 198          | 100          | 100          | 100.0     | 114120  | PASS             |
| 199         | 198          | 5            | 9            | 6.7       | 7602    | PASS             |
| 275         | 198          | 10           | 30           | 23.1      | 26336   | PASS             |
| 365         | 198          | 1            | 100          | 2.5       | 2845    | PASS             |
| 441         | 443          | 0.01         | 100          | 84.1      | 11129   | PASS             |
| 442         | 198          | 40           | 100          | 61.7      | 70408   | PASS             |
| 443         | 442          | 17           | 23           | 18.8      | 13237   | PASS             |



**Figure 6: TYPICAL CONTINUING CALIBRATION SUMMARY**

CONTINUE\_CALIBRATION - CALIBRATION VERIFICATION

Instrument ID :E7  
IC\_Beginning DateTime :04/10/14 15:51  
Spike Amount :25 PPM  
CC/CV File :RDH129  
IC File :RDH120

Column Spec :ZB-SemiVoa ID :0.18MM  
IC\_Ending DateTime :04/10/14 18:06  
HPChem Method :SVE7D10  
Date\_Time :04/10/14 20:01

| M | IDX | Parameters                  | CC_Con | CC%_D | CC_Resp | CCRRF | AvRRF | CC_Rtm | AvRtm | %_RSD | Co_X0 | Co_X1 | Co_X2 | Co_Cor |
|---|-----|-----------------------------|--------|-------|---------|-------|-------|--------|-------|-------|-------|-------|-------|--------|
|   | 1   | 1,4-Dichlorobenzene-d4      | 40.000 | 0     | 236184  | 1     | 1     | 2.866  | 2.865 | 0     |       |       |       |        |
|   | 2   | 1,4-Dioxane                 | 24.932 | -0.3  | 69957   | 0.474 | 0.475 | 1.262  | 1.265 | 6.36  |       |       |       |        |
|   | 3   | N-nitrosodimethylamine      | 22.338 | -10.6 | 87392   | 0.592 | 0.663 | 1.372  | 1.371 | 1.92  |       |       |       |        |
|   | 4   | Pyridine                    | 24.262 | -3.0  | 183749  | 1.245 | 1.283 | 1.396  | 1.397 | 2.73  |       |       |       |        |
|   | 5   | 2-Fluorophenol              |        |       |         |       |       |        |       |       |       |       |       |        |
|   | 6   | Phenol-d5                   |        |       |         |       |       |        |       |       |       |       |       |        |
|   | 7   | Phenol                      | 22.423 | -10.3 | 197093  | 1.335 | 1.489 | 2.536  | 2.535 | 2.55  |       |       |       |        |
|   | 8   | Aniline                     | 24.673 | -1.3  | 277116  | 1.877 | 1.902 | 2.599  | 2.598 | 2.64  |       |       |       |        |
|   | 9   | bis(2-chloroethyl)ether     | 23.556 | -5.8  | 148463  | 1.006 | 1.067 | 2.630  | 2.630 | 3.66  |       |       |       |        |
|   | 10  | 2-Chlorophenol              | 22.391 | -10.4 | 169755  | 1.150 | 1.284 | 2.693  | 2.693 | 3.29  |       |       |       |        |
|   | 11  | 1,3-Dichlorobenzene         | 23.135 | -7.5  | 199038  | 1.348 | 1.457 | 2.823  | 2.822 | 1.68  |       |       |       |        |
|   | 12  | 1,2-Dichlorobenzene-d4      |        |       |         |       |       |        |       |       |       |       |       |        |
|   | 13  | 1,4-Dichlorobenzene         | 22.931 | -8.3  | 201819  | 1.367 | 1.491 | 2.880  | 2.879 | 1.29  |       |       |       |        |
|   | 14  | Benzyl alcohol              | 22.739 | -9.0  | 110549  | 0.749 | 0.823 | 2.952  | 2.956 | 3.27  |       |       |       |        |
|   | 15  | 1,2-Dichlorobenzene         | 22.985 | -8.1  | 189990  | 1.287 | 1.400 | 3.010  | 3.009 | 2.35  |       |       |       |        |
|   | 16  | 2-Methylphenol              | 23.651 | -5.4  | 140091  | 0.949 | 1.003 | 3.034  | 3.032 | 3.37  |       |       |       |        |
|   | 17  | bis(2-chloroisopropyl)ether | 23.562 | -5.8  | 192513  | 1.304 | 1.384 | 3.077  | 3.076 | 3.68  |       |       |       |        |
|   | 18  | 4-Methylphenol              | 23.276 | -6.9  | 177716  | 1.204 | 1.293 | 3.168  | 3.168 | 3.19  |       |       |       |        |
|   | 19  | N-Nitroso-di-n-propylamine  | 22.403 | -10.4 | 103672  | 0.702 | 0.784 | 3.192  | 3.192 | 3.80  |       |       |       |        |
|   | 20  | Hexachloroethane            | 22.794 | -8.8  | 75921   | 0.514 | 0.564 | 3.312  | 3.313 | 2.70  |       |       |       |        |
|   | 21  | Naphthalene-d8              | 40.000 | 0     | 892727  | 1     | 1     | 4.066  | 4.064 | 0     |       |       |       |        |
|   | 22  | Nitrobenzene-d5             |        |       |         |       |       |        |       |       |       |       |       |        |
|   | 23  | Nitrobenzene                | 22.194 | -11.2 | 183217  | 0.328 | 0.370 | 3.355  | 3.358 | 2.02  |       |       |       |        |
|   | 24  | Isophorone                  | 25.643 | 2.6   | 376664  | 0.675 | 0.658 | 3.585  | 3.587 | 8.28  |       |       |       |        |
|   | 25  | 2-Nitrophenol               | 22.051 | -11.8 | 87468   | 0.157 | 0.178 | 3.667  | 3.664 | 6.11  |       |       |       |        |
|   | 26  | 2,4-Dimethylphenol          | 22.620 | -9.5  | 180337  | 0.323 | 0.357 | 3.686  | 3.687 | 4.76  |       |       |       |        |
|   | 27  | Benzoic acid                | 20.404 | -18.4 | 111108  | 0.199 | 0.244 | 3.767  | 3.779 | 10.58 |       |       |       |        |
|   | 28  | bis(2-Chloroethoxy)methane  | 23.447 | -6.2  | 190911  | 0.342 | 0.365 | 3.796  | 3.794 | 2.74  |       |       |       |        |
|   | 29  | 3,5-Dimethylphenol          | 21.933 | -12.3 | 180596  | 0.324 | 0.369 | 3.825  | 3.825 | 10.56 |       |       |       |        |
|   | 30  | 2,4-Dichlorophenol          | 22.510 | -10.0 | 168452  | 0.302 | 0.335 | 3.902  | 3.901 | 1.95  |       |       |       |        |
|   | 31  | 1,2,4-Trichlorobenzene      | 22.451 | -10.2 | 185770  | 0.333 | 0.371 | 4.003  | 4.001 | 1.93  |       |       |       |        |
|   | 32  | 3,4-Dimethylphenol          | 23.048 | -7.8  | 224613  | 0.403 | 0.437 | 3.998  | 4.000 | 3.88  |       |       |       |        |
|   | 33  | Naphthalene                 | 22.617 | -9.5  | 514465  | 0.922 | 1.019 | 4.085  | 4.088 | 1.20  |       |       |       |        |
|   | 34  | 4-Chloroaniline             | 23.283 | -6.9  | 216083  | 0.387 | 0.416 | 4.128  | 4.130 | 2.49  |       |       |       |        |
|   | 35  | 2,6-Dichlorophenol          | 23.965 | -4.1  | 151484  | 0.271 | 0.283 | 4.143  | 4.142 | 3.59  |       |       |       |        |
|   | 36  | Hexachlorobutadiene         | 22.924 | -8.3  | 129760  | 0.233 | 0.254 | 4.220  | 4.221 | 2.29  |       |       |       |        |
|   | 37  | Hydroquinone                |        |       |         |       |       |        |       |       |       |       |       |        |
|   | 38  | 4-Chloro-3-methylphenol     | 21.618 | -13.5 | 134354  | 0.241 | 0.278 | 4.654  | 4.653 | 2.25  |       |       |       |        |
|   | 39  | 2-Methylnaphthalene         | 22.657 | -9.4  | 348859  | 0.625 | 0.690 | 4.846  | 4.846 | 1.32  |       |       |       |        |
|   | 40  | 1-Methylnaphthalene         | 23.384 | -6.5  | 329637  | 0.591 | 0.632 | 4.956  | 4.958 | 1.95  |       |       |       |        |
|   | 41  | Acenaphthene-d10            | 40.000 | 0     | 490143  | 1     | 1     | 6.062  | 6.061 | 0     |       |       |       |        |
|   | 42  | Hexachlorocyclopentadiene   | 20.470 | -18.1 | 131441  | 0.429 | 0.524 | 5.033  | 5.032 | 5.14  |       |       |       |        |
|   | 43  | 2,3,5-Trichlorophenol       | 28.830 | 15.3  | 119762  | 0.391 | 0.339 | 5.033  | 5.030 | 1.69  |       |       |       |        |
|   | 44  | 2,4,6-Trichlorophenol       | 22.427 | -10.3 | 116051  | 0.379 | 0.422 | 5.163  | 5.160 | 2.21  |       |       |       |        |
|   | 45  | 2,4,5-Trichlorophenol       | 24.747 | -1.0  | 130233  | 0.425 | 0.429 | 5.196  | 5.196 | 4.44  |       |       |       |        |
|   | 46  | 2-Fluorobiphenyl            |        |       |         |       |       |        |       |       |       |       |       |        |
|   | 47  | 2,3,4-Trichlorophenol       | 24.201 | -3.2  | 109305  | 0.357 | 0.369 | 5.269  | 5.271 | 2.79  |       |       |       |        |
|   | 48  | Biphenyl                    | 24.460 | -2.2  | 445998  | 1.456 | 1.488 | 5.384  | 5.385 | 1.35  |       |       |       |        |
|   | 49  | 2-Chloronaphthalene         | 23.038 | -7.8  | 332776  | 1.086 | 1.179 | 5.404  | 5.403 | 1.66  |       |       |       |        |
|   | 50  | 2-Nitroaniline              | 23.173 | -7.3  | 88791   | 0.290 | 0.313 | 5.514  | 5.515 | 4.97  |       |       |       |        |
|   | 51  | 2,6-Dimethylnaphthalene     | 24.654 | -1.4  | 333443  | 1.088 | 1.104 | 5.571  | 5.569 | 1.78  |       |       |       |        |
|   | 52  | 1,4-Dinitrobenzene          | 24.237 | -3.1  | 50453   | 0.165 | 0.170 | 5.677  | 5.679 | 4.29  |       |       |       |        |
|   | 53  | Dimethylphthalate           | 23.149 | -7.4  | 452676  | 1.478 | 1.596 | 5.754  | 5.754 | 1.32  |       |       |       |        |
|   | 54  | 1,3-Dinitrobenzene          | 21.607 | -13.6 | 52316   | 0.171 | 0.198 | 5.768  | 5.767 | 2.00  |       |       |       |        |
|   | 55  | 2,6-Dinitrotoluene          | 23.249 | -7.0  | 83399   | 0.272 | 0.293 | 5.812  | 5.811 | 1.95  |       |       |       |        |

**Figure 6 (cont.): TYPICAL CONTINUING CALIBRATION SUMMARY**

|     |                            |        |       |        |       |       |        |        |       |  |  |  |
|-----|----------------------------|--------|-------|--------|-------|-------|--------|--------|-------|--|--|--|
| 56  | 1,2-Dinitrobenzene         | 24.096 | -3.6  | 33719  | 0.110 | 0.114 | 5.865  | 5.866  | 6.89  |  |  |  |
| 57  | Acenaphthylene             | 23.349 | -6.6  | 541096 | 1.766 | 1.891 | 5.889  | 5.890  | 0.80  |  |  |  |
| 58  | 3-Nitroaniline             | 23.121 | -7.5  | 85538  | 0.279 | 0.302 | 6.000  | 6.002  | 2.88  |  |  |  |
| 59  | Acenaphthene               | 22.946 | -8.2  | 349336 | 1.140 | 1.242 | 6.100  | 6.100  | 1.87  |  |  |  |
| 60  | 2,4-Dinitrophenol          | 22.266 | -10.9 | 43948  | 0.143 | 0.161 | 6.124  | 6.125  | 7.03  |  |  |  |
| 61  | 4-Nitrophenol              | 22.782 | -8.9  | 68322  | 0.223 | 0.245 | 6.201  | 6.199  | 4.70  |  |  |  |
| 62  | 2,4-Dinitrotoluene         | 23.512 | -6.0  | 111877 | 0.365 | 0.388 | 6.287  | 6.287  | 2.60  |  |  |  |
| 63  | Dibenzofuran               | 22.654 | -9.4  | 458083 | 1.495 | 1.650 | 6.306  | 6.306  | 1.34  |  |  |  |
| 64  | 2,3,5,6-Tetrachlorophenol  | 23.149 | -7.4  | 83137  | 0.271 | 0.293 | 6.397  | 6.398  | 5.24  |  |  |  |
| 65  | 2,3,4,6-Tetrachlorophenol  | 20.679 | -17.3 | 98188  | 0.321 | 0.387 | 6.450  | 6.449  | 5.82  |  |  |  |
| 66  | 2,3,5-Trimethylnaphthalene | 25.063 | 0.3   | 300611 | 0.981 | 0.979 | 6.564  | 6.563  | 2.80  |  |  |  |
| 67  | Diethylphthalate           | 23.039 | -7.8  | 402694 | 1.315 | 1.426 | 6.606  | 6.608  | 1.28  |  |  |  |
| 68  | Fluorene                   | 22.257 | -11.0 | 366505 | 1.196 | 1.344 | 6.719  | 6.718  | 1.79  |  |  |  |
| 69  | 4-Chlorophenyl-phenylether | 22.927 | -8.3  | 191484 | 0.625 | 0.682 | 6.733  | 6.731  | 0.94  |  |  |  |
| 70  | 4-Nitroaniline             | 24.201 | -3.2  | 89054  | 0.291 | 0.300 | 6.733  | 6.732  | 2.83  |  |  |  |
| 71  | Phenanthrene-d10           | 40.000 | 0     | 919199 | 1     | 1     | 7.796  | 7.797  | 0     |  |  |  |
| 72  | 4,6-Dinitro-2-methylphenol | 24.229 | -3.1  | 64140  | 0.112 | 0.115 | 6.775  | 6.775  | 14.46 |  |  |  |
| 73  | N-Nitrosodiphenylamine     | 23.461 | -6.2  | 307643 | 0.535 | 0.571 | 6.869  | 6.870  | 2.15  |  |  |  |
| 74  | Azobenzene                 | 21.761 | -13.0 | 337764 | 0.588 | 0.675 | 6.917  | 6.918  | 2.94  |  |  |  |
| 75  | 2,4,6-Tribromophenol       |        |       |        |       |       |        |        |       |  |  |  |
| 76  | 4-Bromophenyl-phenylether  | 24.111 | -3.6  | 114341 | 0.199 | 0.206 | 7.301  | 7.302  | 1.74  |  |  |  |
| 77  | Hexachlorobenzene          | 22.913 | -8.3  | 118046 | 0.205 | 0.224 | 7.362  | 7.361  | 1.26  |  |  |  |
| 78  | Pentachlorophenol          | 23.935 | -4.3  | 81305  | 0.142 | 0.148 | 7.584  | 7.582  | 5.21  |  |  |  |
| 79  | Dibenzothiophene           | 23.518 | -5.9  | 511803 | 0.891 | 0.947 | 7.679  | 7.679  | 2.00  |  |  |  |
| 80  | Phenanthrene               | 22.694 | -9.2  | 524956 | 0.914 | 1.007 | 7.825  | 7.822  | 1.25  |  |  |  |
| 81  | Dinoseb                    |        |       |        |       |       |        |        |       |  |  |  |
| 82  | Anthracene                 | 22.872 | -8.5  | 541793 | 0.943 | 1.031 | 7.876  | 7.877  | 2.39  |  |  |  |
| 83  | Carbazole                  | 23.627 | -5.5  | 511559 | 0.890 | 0.942 | 8.055  | 8.055  | 1.57  |  |  |  |
| 84  | Di-n-butylphthalate        | 23.206 | -7.2  | 652551 | 1.136 | 1.224 | 8.470  | 8.467  | 4.52  |  |  |  |
| 85  | 1-Methylphenanthrene       | 24.442 | -2.2  | 424846 | 0.740 | 0.756 | 8.494  | 8.493  | 2.43  |  |  |  |
| 86  | Fluoranthene               | 21.256 | -15.0 | 599853 | 1.044 | 1.228 | 9.098  | 9.097  | 7.92  |  |  |  |
| 87  | Chrysene-d12               | 40.000 | 0     | 962830 | 1     | 1     | 10.567 | 10.565 | 0     |  |  |  |
| 88  | Benzidine                  |        |       |        |       |       |        |        |       |  |  |  |
| 89  | Pyrene                     | 22.417 | -10.3 | 635848 | 1.057 | 1.178 | 9.329  | 9.330  | 2.15  |  |  |  |
| 90  | Terphenyl-d14              |        |       |        |       |       |        |        |       |  |  |  |
| 91  | Butylbenzylphthalate       | 24.144 | -3.4  | 287923 | 0.478 | 0.495 | 10.016 | 10.013 | 5.78  |  |  |  |
| 92  | bis(2-ethylhexyl)adipate   | 23.931 | -4.3  | 228198 | 0.379 | 0.396 | 10.108 | 10.109 | 5.76  |  |  |  |
| 93  | 3,3'-Dichlorobenzidine     | 23.151 | -7.4  | 215515 | 0.358 | 0.387 | 10.528 | 10.528 | 1.43  |  |  |  |
| 94  | Benzo(a)anthracene         | 22.565 | -9.7  | 612810 | 1.018 | 1.128 | 10.552 | 10.553 | 1.48  |  |  |  |
| 95  | Chrysene                   | 22.740 | -9.0  | 556264 | 0.924 | 1.016 | 10.591 | 10.589 | 2.32  |  |  |  |
| 96  | bis(2-Ethylhexyl)phthalate | 23.271 | -6.9  | 431382 | 0.717 | 0.770 | 10.601 | 10.602 | 4.61  |  |  |  |
| 97  | Perylene-d12               | 40.000 | 0     | 949618 | 1     | 1     | 11.926 | 11.927 | 0     |  |  |  |
| 98  | Di-n-octylphthalate        | 23.347 | -6.6  | 735924 | 1.240 | 1.328 | 11.217 | 11.218 | 6.06  |  |  |  |
| 99  | Benzo(b)fluoranthene       | 22.146 | -11.4 | 572045 | 0.964 | 1.088 | 11.563 | 11.561 | 4.73  |  |  |  |
| 100 | Benzo(k)fluoranthene       | 23.377 | -6.5  | 584658 | 0.985 | 1.053 | 11.587 | 11.588 | 4.31  |  |  |  |
| 101 | Benzo(e)pyrene             | 24.842 | -0.6  | 591183 | 0.996 | 1.002 | 11.819 | 11.818 | 3.35  |  |  |  |
| 102 | Benzo(a)pyrene             | 22.403 | -10.4 | 538072 | 0.907 | 1.012 | 11.868 | 11.870 | 4.47  |  |  |  |
| 103 | Perylene                   | 22.655 | -9.4  | 557932 | 0.940 | 1.037 | 11.950 | 11.952 | 3.09  |  |  |  |
| 104 | Indeno(1,2,3-cd)pyrene     | 23.046 | -7.8  | 631945 | 1.065 | 1.155 | 13.116 | 13.120 | 2.77  |  |  |  |
| 105 | Dibenzo(a,h)anthracene     | 23.005 | -8.0  | 513056 | 0.864 | 0.939 | 13.136 | 13.140 | 3.75  |  |  |  |
| 106 | Benzo(g,h,i)perylene       | 22.976 | -8.1  | 532510 | 0.897 | 0.976 | 13.470 | 13.473 | 2.54  |  |  |  |

**Figure 6A: TYPICAL CONTINUING CALIBRATION SUMMARY OF BENZIDINE**

CONTINUE\_CALIBRATION - CALIBRATION VERIFICATION

Instrument ID :E7  
 IC\_Beginning DateTime :04/10/14 20:20  
 Spike Amount :25 PPM  
 CC/CV File :RDH137  
 IC File :RDH134

Column Spec :ZB-SemiVoa ID :0.18MM  
 IC\_Ending DateTime :04/10/14 22:16  
 HPChem Method :SVE7D10A  
 Date\_Time :04/10/14 22:36

| M_IDX | Parameters             | CC_Con | CC%_D | CC_Resp | CCRRF | AvRRF | CC_Rtm | AvRtm | %_RSD | Co_X0 | Co_X1 | Co_X2 | Co_Cor |
|-------|------------------------|--------|-------|---------|-------|-------|--------|-------|-------|-------|-------|-------|--------|
| 1     | 1,4-Dichlorobenzene-d4 | 40.000 | 0     | 346380  | 1     | 1     | 2.861  | 2.862 | 0     |       |       |       |        |
| 2     | Benzaldehyde           |        |       |         |       |       |        |       |       |       |       |       |        |
| 3     | Caprolactam            |        |       |         |       |       |        |       |       |       |       |       |        |
| 4     | Phenanthrene-d10       | 40.000 | 0     | 834502  | 1     | 1     | 7.797  | 7.797 | 0     |       |       |       |        |
| 5     | Benzidine              | 23.091 | -7.6  | 372153  | 0.714 | 0.773 | 9.238  | 9.242 | 5.16  |       |       |       |        |





**Figure 6B (cont.): TYPICAL CONTINUING CALIBRATION SUMMARY OF  
 ANALYTES APPENDIX IX**

|    |                               |        |      |        |       |       |        |        |       |
|----|-------------------------------|--------|------|--------|-------|-------|--------|--------|-------|
| 41 | Pentachlorobenzene            | 26.133 | 4.5  | 165684 | 0.561 | 0.537 | 6.258  | 6.256  | 1.70  |
| 42 | 1-Naphthylamine               | 26.797 | 7.2  | 340129 | 1.152 | 1.075 | 6.393  | 6.392  | 1.82  |
| 43 | 2,3,4,6-Tetrachlorophenol     |        |      |        |       |       |        |        |       |
| 44 | 2-Naphthylamine               | 25.795 | 3.2  | 362974 | 1.230 | 1.192 | 6.489  | 6.488  | 4.73  |
| 45 | Thionazin                     | 26.482 | 5.9  | 53904  | 0.183 | 0.172 | 6.700  | 6.699  | 4.45  |
| 46 | 5-Nitro-o-toluidine           | 26.914 | 7.7  | 98851  | 0.335 | 0.311 | 6.723  | 6.725  | 2.86  |
| 47 | Phenanthrene-d10              | 40.000 | 0    | 897257 | 1     | 1     | 7.796  | 7.799  | 0     |
| 48 | 2,4,6-Tribromophenol          |        |      |        |       |       |        |        |       |
| 49 | Sulfotepp                     | 26.272 | 5.1  | 39561  | 0.071 | 0.067 | 7.083  | 7.084  | 5.08  |
| 50 | 1,3,5-Trinitrobenzene         | 26.235 | 4.9  | 31338  | 0.056 | 0.053 | 7.163  | 7.166  | 12.28 |
| 51 | Phorate                       | 27.525 | 10.1 | 233279 | 0.416 | 0.378 | 7.230  | 7.230  | 1.57  |
| 52 | Phenacetin                    | 26.331 | 5.3  | 201737 | 0.360 | 0.342 | 7.239  | 7.240  | 2.59  |
| 53 | Diallate                      | 26.990 | 8.0  | 17045  | 0.030 | 0.028 | 7.320  | 7.322  | 3.49  |
| 54 | Dimethoate                    | 26.661 | 6.6  | 105997 | 0.189 | 0.177 | 7.409  | 7.411  | 5.69  |
| 55 | Atrazine                      | 26.216 | 4.9  | 104341 | 0.186 | 0.177 | 7.504  | 7.503  | 7.44  |
| 56 | Pentachloronitrobenzene       | 26.988 | 8.0  | 66443  | 0.118 | 0.110 | 7.603  | 7.604  | 3.80  |
| 57 | 4-Aminobiphenyl               | 25.698 | 2.8  | 383831 | 0.684 | 0.666 | 7.594  | 7.594  | 1.11  |
| 58 | Pronamide                     | 25.511 | 2.0  | 193073 | 0.344 | 0.337 | 7.683  | 7.681  | 1.71  |
| 59 | Dinoseb                       | 27.411 | 9.6  | 90062  | 0.161 | 0.146 | 7.806  | 7.806  | 8.34  |
| 60 | Disulfoton                    | 26.641 | 6.6  | 152036 | 0.271 | 0.254 | 7.825  | 7.824  | 4.54  |
| 61 | Chrysene-d12                  | 40.000 | 0    | 912248 | 1     | 1     | 10.562 | 10.562 | 0     |
| 62 | Methyl parathion              | 27.196 | 8.8  | 112386 | 0.197 | 0.181 | 8.224  | 8.224  | 4.04  |
| 63 | Ethyl parathion               | 27.100 | 8.4  | 78996  | 0.139 | 0.128 | 8.649  | 8.647  | 6.80  |
| 64 | 4-Nitroquinoline-N-oxide      | 27.734 | 10.9 | 54674  | 0.096 | 0.086 | 8.653  | 8.653  | 6.78  |
| 65 | Methapyrilene                 | 27.737 | 10.9 | 185847 | 0.326 | 0.294 | 8.765  | 8.763  | 6.69  |
| 66 | Isodrin                       | 26.753 | 7.0  | 73147  | 0.128 | 0.120 | 8.948  | 8.947  | 4.26  |
| 67 | Terphenyl-d14                 |        |      |        |       |       |        |        |       |
| 68 | Aramite                       | 26.566 | 6.3  | 31743  | 0.056 | 0.052 | 9.576  | 9.576  | 5.90  |
| 69 | p-Dimethylaminoazobenzene     | 26.486 | 5.9  | 149654 | 0.262 | 0.248 | 9.649  | 9.650  | 3.61  |
| 70 | Chlorobenzilate               | 27.780 | 11.1 | 163928 | 0.288 | 0.259 | 9.703  | 9.704  | 5.49  |
| 71 | 3,3-Dimethylbenzidine         | 26.573 | 6.3  | 328992 | 0.577 | 0.543 | 9.986  | 9.988  | 7.37  |
| 72 | Perylene-d12                  | 40.000 | 0    | 911888 | 1     | 1     | 11.926 | 11.926 | 0     |
| 73 | 2-Acetylaminofluorene         | 27.124 | 8.5  | 273538 | 0.480 | 0.442 | 10.240 | 10.240 | 6.11  |
| 74 | 7,12-Dimethylben(a)anthracene | 26.412 | 5.6  | 262003 | 0.460 | 0.435 | 11.553 | 11.553 | 4.04  |
| 75 | 3-Methylcholanthrene          | 25.078 | 0.3  | 274943 | 0.482 | 0.481 | 12.217 | 12.219 | 3.80  |
| 76 | Dibenzo(a,j)acridine          | 26.759 | 7.0  | 450787 | 0.791 | 0.739 | 12.888 | 12.886 | 5.22  |

**Figure 6C: TYPICAL CONTINUING CALIBRATION SUMMARY OF  
 ADDITIONAL ANALYTES APPENDIX IX**

CONTINUE\_CALIBRATION - CALIBRATION VERIFICATION

Instrument ID :E7  
 IC\_Beginning DateTime :04/11/14 14:56  
 Spike Amount :50 PPM  
 CC/CV File :RDH155  
 IC File :RDH152

Column Spec :ZB-SemiVoa ID :0.18MM  
 IC\_Ending DateTime :04/11/14 16:51  
 HPChem Method :SVE7D11C  
 Date\_Time :04/11/14 17:10

| M ID | Parameters             | CC_Con | CC%_D | CC_Resp | CCRRF | AvRRF | CC_Rtm | AvRtm  | %_RSD | Co_X0   | Co_X1  | Co_X2 | Co_Cor |
|------|------------------------|--------|-------|---------|-------|-------|--------|--------|-------|---------|--------|-------|--------|
| 1    | 1,4-Dichlorobenzene-d4 | 40.000 | 0     | 268288  | 1     | 1     | 2.861  | 2.862  | 0     |         |        |       |        |
| 2    | Naphthalene-d8         | 40.000 | 0     | 966151  | 1     | 1     | 4.061  | 4.063  | 0     |         |        |       |        |
| 3    | Acenaphthene-d10       | 40.000 | 0     | 521650  | 1     | 1     | 6.062  | 6.059  | 0     |         |        |       |        |
| 4    | Phenanthrene-d10       | 40.000 | 0     | 1036706 | 1     | 1     | 7.797  | 7.796  | 0     |         |        |       |        |
| 5    | Chrysene-d12           | 40.000 | 0     | 1071961 | 1     | 1     | 10.562 | 10.567 | 0     |         |        |       |        |
| 6    | Famphur                | 51.359 | 2.7   | 731295  | 0.546 | 0.531 | 9.952  | 9.959  | 2.38  |         |        |       |        |
| 7    | Kepone                 | 48.840 | -2.3  | 136412  | 0.102 | 0.104 | 10.040 | 10.040 | 1.74  |         |        |       |        |
| 8    | Perylene-d12           | 40.000 | 0     | 1015463 | 1     | 1     | 11.926 | 11.933 | 0     |         |        |       |        |
| 9    | Hexachlorophene        | 55.518 | 11.0  | 158347  | 0.125 | 0.111 | 11.727 | 11.731 | 17.61 | -0.0344 | 0.1372 |       | 0.9982 |



**Figure 7B: TYPICAL INTERNAL STANDARD AREA AND RT SUMMARY SV-2**

8C  
 SEMIVOLATILE INTERNAL STANDARD AREA AND RT SUMMARY

Lab Name: EMAX Inc Project: ICAL  
 Lab Code: EMXT SDG No.: CAL\8270\2014  
 Lab File ID: RDH120 Date Analyzed: 04/10/14  
 Instrument ID: TOE7 Time Analyzed: 17:08

|             | IS4(PHN)<br>AREA # | RT # | IS5(CRY)<br>AREA # | RT #  | IS6(PRY)<br>AREA # | RT #  |
|-------------|--------------------|------|--------------------|-------|--------------------|-------|
| 12 HOUR STD | 939603             | 7.80 | 976667             | 10.57 | 953304             | 11.93 |
| UPPER LIMIT | 1879206            | 8.30 | 1953334            | 11.07 | 1906608            | 12.43 |
| LOWER LIMIT | 469802             | 7.30 | 488334             | 10.07 | 476652             | 11.43 |
| SAMPLE ID   |                    |      |                    |       |                    |       |
| 1 SVE7D101  | 913375             | 7.80 | 935897             | 10.56 | 923517             | 11.93 |
| 2 SVE7D102  | 873339             | 7.80 | 901672             | 10.56 | 894094             | 11.93 |
| 3 SVE7D103  | 928269             | 7.80 | 971213             | 10.57 | 940714             | 11.93 |
| 4 SVE7D104  | 936666             | 7.80 | 985427             | 10.57 | 952812             | 11.93 |
| 5 SVE7D106  | 931801             | 7.80 | 980634             | 10.57 | 946988             | 11.93 |
| 6 SVE7D107  | 958223             | 7.80 | 983938             | 10.57 | 969359             | 11.93 |
| 7 SVE7D108  | 926152             | 7.80 | 941776             | 10.56 | 937143             | 11.92 |
| 8 ISVE7D101 | 919199             | 7.80 | 962830             | 10.57 | 949618             | 11.93 |

IS4 (PHN) = Phenanthrene-d10  
 IS5 (CRY) = Chrysene-d12  
 IS6 (PRY) = Perylene-d12

AREA UPPER LIMIT = +100% of internal standard area  
 AREA LOWER LIMIT = - 50% of internal standard area  
 RT UPPER LIMIT = +0.50 minutes of internal standard RT  
 RT LOWER LIMIT = -0.50 minutes of internal standard RT

# Column used to flag internal standard area values with an asterisk  
 \* Values outside of QC limits.

**Figure 8: TYPICAL SAMPLE RESULT**

METHOD SW3550B/8270C  
 SEMI VOLATILE ORGANICS BY GC/MS

|                          |                                |
|--------------------------|--------------------------------|
| Client : XYZ, INC.       | Date Collected: 06/09/14       |
| Project : CLEAN PROJECT  | Date Received: 06/10/14        |
| Batch No. : 14F050       | Date Extracted: 06/19/14 12:14 |
| Sample ID: 507-DR-SO-011 | Date Analyzed: 06/19/14 21:17  |
| Lab Samp ID: F050-12     | Dilution Factor: 1             |
| Lab File ID: RFH297      | Matrix : SOIL                  |
| Ext Btch ID: SVF031S     | % Moisture : 21.5              |
| Calib. Ref.: RDH120      | Instrument ID : T-OE7          |

| PARAMETERS                   | RESULTS<br>(ug/kg) | LOQ<br>(ug/kg) | LOD<br>(ug/kg) |
|------------------------------|--------------------|----------------|----------------|
| 1,2,4-TRICHLOROBENZENE       | ND                 | 420            | 210            |
| 1,2-DICHLOROBENZENE          | ND                 | 420            | 210            |
| 1,2-DIPHENYLHYDRAZINE        | ND                 | 420            | 210            |
| 1,3-DICHLOROBENZENE          | ND                 | 420            | 210            |
| 1,4-DICHLOROBENZENE          | ND                 | 420            | 210            |
| 2,4,5-TRICHLOROPHENOL        | ND                 | 420            | 210            |
| 2,4,6-TRICHLOROPHENOL        | ND                 | 420            | 210            |
| 2,4-DICHLOROPHENOL           | ND                 | 420            | 210            |
| 2,4-DIMETHYLPHENOL           | ND                 | 420            | 210            |
| 2,4-DINITROPHENOL            | ND                 | 850            | 210            |
| 2,4-DINITROTOLUENE           | ND                 | 420            | 210            |
| 2,6-DINITROTOLUENE           | ND                 | 420            | 210            |
| 2-CHLORONAPHTHALENE          | ND                 | 420            | 210            |
| 2-CHLOROPHENOL               | ND                 | 420            | 210            |
| 2-METHYLNAPHTHALENE          | ND                 | 420            | 210            |
| 2-METHYLPHENOL               | ND                 | 420            | 210            |
| 2-NITROANILINE               | ND                 | 420            | 210            |
| 2-NITROPHENOL                | ND                 | 420            | 210            |
| 3,3'-DICHLOROBENZIDINE       | ND                 | 420            | 210            |
| 4-METHYLPHENOL (1)           | ND                 | 420            | 210            |
| 3-NITROANILINE               | ND                 | 420            | 210            |
| 4,6-DINITRO-2-METHYLPHENOL   | ND                 | 850            | 210            |
| 4-BROMOPHENYL-PHENYL ETHER   | ND                 | 420            | 210            |
| 4-CHLORO-3-METHYLPHENOL      | ND                 | 420            | 210            |
| 4-CHLOROANILINE              | ND                 | 420            | 210            |
| 4-CHLOROPHENYL-PHENYL ETHER  | ND                 | 420            | 210            |
| 4-NITROANILINE               | ND                 | 420            | 210            |
| 4-NITROPHENOL                | ND                 | 850            | 210            |
| ACENAPHTHENE                 | ND                 | 420            | 210            |
| ACENAPHTHYLENE               | ND                 | 420            | 210            |
| ANTHRACENE                   | ND                 | 420            | 210            |
| BENZO(A)ANTHRACENE           | ND                 | 420            | 210            |
| BENZO(A)PYRENE               | ND                 | 420            | 210            |
| BENZO(B)FLUORANTHENE         | ND                 | 420            | 210            |
| BENZO(G,H,I)PERYLENE         | ND                 | 420            | 210            |
| BENZO(K)FLUORANTHENE         | ND                 | 420            | 210            |
| BENZOIC ACID                 | ND                 | 1700           | 850            |
| BENZYL ALCOHOL               | ND                 | 420            | 210            |
| 2,2'-OXYBIS(1-CHLOROPROPANE) | ND                 | 420            | 210            |
| BIS(2-CHLOROETHOXY)METHANE   | ND                 | 420            | 210            |
| BIS(2-CHLOROETHYL)ETHER      | ND                 | 420            | 210            |
| BIS(2-ETHYLHEXYL)PHTHALATE   | ND                 | 420            | 210            |
| BUTYLBENZYLPHTHALATE         | ND                 | 420            | 210            |
| CARBAZOLE                    | ND                 | 420            | 210            |
| CHRYSENE                     | ND                 | 420            | 210            |
| DIBENZO(A,H)ANTHRACENE       | ND                 | 420            | 210            |
| DIBENZOFURAN                 | ND                 | 420            | 210            |
| DIETHYLPHTHALATE             | ND                 | 420            | 210            |
| DIMETHYLPHTHALATE            | ND                 | 420            | 210            |
| DI-N-BUTYLPHTHALATE          | ND                 | 420            | 210            |
| DI-N-OCTYLPHTHALATE          | ND                 | 420            | 210            |
| FLUORANTHENE                 | ND                 | 420            | 210            |
| FLUORENE                     | ND                 | 420            | 210            |
| HEXACHLOROBENZENE            | ND                 | 420            | 210            |
| HEXACHLOROBUTADIENE          | ND                 | 420            | 210            |
| HEXACHLOROETHANE             | ND                 | 420            | 210            |

**Figure 8 (cont.): TYPICAL SAMPLE RESULT**

|                            |         |         |            |          |
|----------------------------|---------|---------|------------|----------|
| INDENO(1,2,3-CD)PYRENE     | ND      | 420     |            | 210      |
| ISOPHORONE                 | ND      | 420     |            | 210      |
| NAPHTHALENE                | ND      | 420     |            | 210      |
| NITROBENZENE               | ND      | 420     |            | 210      |
| N-NITROSODIMETHYLAMINE     | ND      | 420     |            | 210      |
| N-NITROSO-DI-N-PROPYLAMINE | ND      | 420     |            | 210      |
| N-NITROSODIPHENYLAMINE (2) | ND      | 420     |            | 210      |
| PENTACHLOROPHENOL          | ND      | 850     |            | 210      |
| PHENANTHRENE               | ND      | 420     |            | 210      |
| PHENOL                     | ND      | 420     |            | 210      |
| PYRENE                     | ND      | 420     |            | 210      |
| BENZIDINE                  | ND      | 2500    |            | 1100     |
| 2,6-DICHLOROPHENOL         | ND      | 420     |            | 210      |
| SURROGATE PARAMETERS       | RESULTS | SPK_AMT | % RECOVERY | QC LIMIT |
| 2,4,6-TRIBROMOPHENOL       | 1950    | 2548    | 76.6       | 35-125   |
| 2-FLUOROBIPHENYL           | 520     | 849.3   | 61.2       | 45-105   |
| 2-FLUOROPHENOL             | 1380    | 2548    | 54.1       | 35-105   |
| NITROBENZENE-D5            | 455     | 849.3   | 53.6       | 35-100   |
| PHENOL-D5                  | 1460    | 2548    | 57.1       | 40-100   |
| TERPHENYL-D14              | 610     | 849.3   | 71.8       | 30-125   |

(1): Cannot be separated from 3-Methylphenol  
 (2): Cannot be separated from Diphenylamine

Figure 9:

## TYPICAL LCS/LCSD SUMMARY

EMAX QUALITY CONTROL DATA  
LCS/LCD ANALYSIS

CLIENT: XYZ, INC.  
PROJECT: CLEAN PROJECT  
BATCH NO.: 14F050  
METHOD: SW3550B/8270C

MATRIX: SOIL  
DILUTION FACTOR: 1 1 % MOISTURE: NA  
SAMPLE ID: MBLK15  
LAB SAMP ID: SVF0315B SVF0315L SVF0315C  
LAB FILE ID: RFH277 RFH278 RFH279  
DATE EXTRACTED: 06/19/1412:14 06/19/1412:14 06/19/1412:14 DATE COLLECTED: NA  
DATE ANALYZED: 06/19/1414:50 06/19/1415:09 06/19/1415:28 DATE RECEIVED: 06/19/14  
PREP. BATCH: SVF0315 SVF0315 SVF0315  
CALIB. REF: RDH120 RDH120 RDH120

## ACCESSION:

| PARAMETER                    | BLNK RSLT<br>(ug/kg) | SPIKE AMT<br>(ug/kg) | BS RSLT<br>(ug/kg) | BS<br>% REC | SPIKE AMT<br>(ug/kg) | BSD RSLT<br>(ug/kg) | BSD<br>% REC | RPD<br>( % ) | QC LIMIT<br>( % ) | MAX RPD<br>( % ) |
|------------------------------|----------------------|----------------------|--------------------|-------------|----------------------|---------------------|--------------|--------------|-------------------|------------------|
| 1,2,4-Trichlorobenzene       | ND                   | 1330                 | 884                | 66          | 1330                 | 869                 | 65           | 2            | 45-110            | 50               |
| 1,2-Dichlorobenzene          | ND                   | 1330                 | 971                | 73          | 1330                 | 974                 | 73           | 0            | 45-100            | 50               |
| 1,2-Diphenylhydrazine        | ND                   | 1330                 | 1070               | 80          | 1330                 | 1010                | 76           | 6            | 30-130            | 50               |
| 1,3-Dichlorobenzene          | ND                   | 1330                 | 960                | 72          | 1330                 | 943                 | 71           | 2            | 40-100            | 50               |
| 1,4-Dichlorobenzene          | ND                   | 1330                 | 980                | 74          | 1330                 | 965                 | 72           | 2            | 35-105            | 50               |
| 2,4,5-Trichloropheno1        | ND                   | 1330                 | 981                | 74          | 1330                 | 939                 | 70           | 4            | 50-110            | 50               |
| 2,4,6-Trichloropheno1        | ND                   | 1330                 | 1130               | 85          | 1330                 | 1080                | 81           | 5            | 45-110            | 50               |
| 2,4-Dichloropheno1           | ND                   | 1330                 | 1110               | 83          | 1330                 | 1060                | 80           | 4            | 45-110            | 50               |
| 2,4-Dimethylpheno1           | ND                   | 1330                 | 1120               | 84          | 1330                 | 1080                | 81           | 4            | 30-105            | 50               |
| 2,4-Dinitrophenol            | ND                   | 1330                 | 936                | 70          | 1330                 | 916                 | 69           | 2            | 15-130            | 50               |
| 2,4-Dinitrotoluene           | ND                   | 1330                 | 1080               | 81          | 1330                 | 1060                | 80           | 1            | 50-115            | 50               |
| 2,6-Dinitrotoluene           | ND                   | 1330                 | 1040               | 78          | 1330                 | 1030                | 77           | 2            | 50-110            | 50               |
| 2-Chloronaphthalene          | ND                   | 1330                 | 1030               | 77          | 1330                 | 994                 | 75           | 4            | 45-105            | 50               |
| 2-Chloropheno1               | ND                   | 1330                 | 1210               | 91          | 1330                 | 1170                | 88           | 4            | 45-105            | 50               |
| 2-Methylnaphthalene          | ND                   | 1330                 | 942                | 71          | 1330                 | 932                 | 70           | 1            | 45-105            | 50               |
| 2-Methylpheno1               | ND                   | 1330                 | 973                | 73          | 1330                 | 956                 | 72           | 2            | 40-105            | 50               |
| 2-Nitroaniline               | ND                   | 1330                 | 1050               | 78          | 1330                 | 1020                | 76           | 3            | 45-120            | 50               |
| 2-Nitrophenol                | ND                   | 1330                 | 1280               | 96          | 1330                 | 1110                | 84           | 14           | 40-110            | 50               |
| 3,3'-Dichlorobenzidine       | ND                   | 1330                 | 1130               | 84          | 1330                 | 1060                | 79           | 6            | 10-130            | 50               |
| 4-Methylpheno1               | ND                   | 1330                 | 1040               | 78          | 1330                 | 985                 | 74           | 5            | 40-105            | 50               |
| 3-Nitroaniline               | ND                   | 1330                 | 1060               | 80          | 1330                 | 1010                | 76           | 5            | 25-110            | 50               |
| 4,6-Dinitro-2-Methylpheno1   | ND                   | 1330                 | 1330               | 100         | 1330                 | 1280                | 96           | 4            | 30-135            | 50               |
| 4-Bromophenyl-phenyl ether   | ND                   | 1330                 | 1170               | 88          | 1330                 | 1110                | 83           | 6            | 45-115            | 50               |
| 4-Chloro-3-Methylpheno1      | ND                   | 1330                 | 1220               | 91          | 1330                 | 1150                | 86           | 5            | 45-115            | 50               |
| 4-Chloroaniline              | ND                   | 1330                 | 958                | 72          | 1330                 | 936                 | 70           | 2            | 10-100            | 50               |
| 4-Chlorophenyl-phenyl ether  | ND                   | 1330                 | 1050               | 79          | 1330                 | 1010                | 76           | 4            | 45-110            | 50               |
| 4-Nitroaniline               | ND                   | 1330                 | 952                | 71          | 1330                 | 925                 | 69           | 3            | 35-115            | 50               |
| 4-Nitrophenol                | ND                   | 1330                 | 865                | 65          | 1330                 | 837                 | 63           | 3            | 15-140            | 50               |
| Acenaphthene                 | ND                   | 1330                 | 1050               | 79          | 1330                 | 1030                | 77           | 2            | 45-110            | 50               |
| Acenaphthylene               | ND                   | 1330                 | 1050               | 79          | 1330                 | 1030                | 77           | 2            | 45-105            | 50               |
| Anthracene                   | ND                   | 1330                 | 1120               | 84          | 1330                 | 1060                | 80           | 5            | 55-105            | 50               |
| Benzo(a)anthracene           | ND                   | 1330                 | 1100               | 82          | 1330                 | 1060                | 79           | 4            | 50-110            | 50               |
| Benzo(a)pyrene               | ND                   | 1330                 | 1130               | 84          | 1330                 | 1080                | 81           | 4            | 50-110            | 50               |
| Benzo(b)fluoranthene         | ND                   | 1330                 | 1080               | 81          | 1330                 | 1080                | 81           | 1            | 45-115            | 50               |
| Benzo(g,h,i)perylene         | ND                   | 1330                 | 1130               | 84          | 1330                 | 1080                | 81           | 4            | 40-125            | 50               |
| Benzo(k)fluoranthene         | ND                   | 1330                 | 1150               | 86          | 1330                 | 1050                | 79           | 9            | 45-125            | 50               |
| Benzoic Acid                 | ND                   | 2670                 | 1720               | 64          | 2670                 | 1730                | 65           | 1            | 0-110             | 50               |
| Benzyl Alcohol               | ND                   | 1330                 | 963                | 72          | 1330                 | 930                 | 70           | 4            | 20-125            | 50               |
| 2,2'-oxybis(1-chloropropane) | ND                   | 1330                 | 1120               | 84          | 1330                 | 1100                | 82           | 2            | 20-115            | 50               |
| bis(2-Chloroethoxy)methane   | ND                   | 1330                 | 1050               | 79          | 1330                 | 1010                | 76           | 3            | 45-110            | 50               |
| bis(2-Chloroethyl)ether      | ND                   | 1330                 | 1020               | 77          | 1330                 | 978                 | 73           | 4            | 40-105            | 50               |
| bis(2-Ethylhexyl)phthalate   | ND                   | 1330                 | 1200               | 90          | 1330                 | 1130                | 85           | 6            | 45-125            | 50               |
| Butylbenzylphthalate         | ND                   | 1330                 | 1220               | 91          | 1330                 | 1160                | 87           | 5            | 50-125            | 50               |
| Carbazole                    | ND                   | 1330                 | 1040               | 78          | 1330                 | 1000                | 75           | 4            | 45-115            | 50               |
| Chrysene                     | ND                   | 1330                 | 1090               | 82          | 1330                 | 1050                | 79           | 4            | 55-110            | 50               |
| Dibenzo(a,h)anthracene       | ND                   | 1330                 | 1190               | 89          | 1330                 | 1150                | 86           | 3            | 40-125            | 50               |
| Dibenzofuran                 | ND                   | 1330                 | 1100               | 82          | 1330                 | 1060                | 79           | 4            | 50-105            | 50               |
| Diethylphthalate             | ND                   | 1330                 | 1110               | 83          | 1330                 | 1050                | 79           | 6            | 50-115            | 50               |
| Dimethylphthalate            | ND                   | 1330                 | 940                | 71          | 1330                 | 899                 | 67           | 4            | 50-110            | 50               |
| Di-n-butylphthalate          | ND                   | 1330                 | 1290               | 97          | 1330                 | 1290                | 97           | 0            | 55-110            | 50               |
| Di-n-octylphthalate          | ND                   | 1330                 | 1150               | 86          | 1330                 | 1100                | 83           | 4            | 40-130            | 50               |
| Fluoranthene                 | ND                   | 1330                 | 1010               | 76          | 1330                 | 966                 | 72           | 5            | 55-115            | 50               |
| Fluorene                     | ND                   | 1330                 | 1050               | 79          | 1330                 | 1010                | 75           | 4            | 50-110            | 50               |



**Figure 9: TYPICAL LCS/LCSD SUMMARY**

|                            |    |      |      |    |      |      |    |   |        |    |
|----------------------------|----|------|------|----|------|------|----|---|--------|----|
| Hexachlorobenzene          | ND | 1330 | 1220 | 91 | 1330 | 1200 | 90 | 2 | 45-120 | 50 |
| Hexachlorobutadiene        | ND | 1330 | 829  | 62 | 1330 | 817  | 61 | 2 | 40-115 | 50 |
| Hexachloroethane           | ND | 1330 | 967  | 73 | 1330 | 966  | 72 | 0 | 35-110 | 50 |
| Indeno(1,2,3-cd)pyrene     | ND | 1330 | 1120 | 84 | 1330 | 1090 | 82 | 3 | 40-120 | 50 |
| Isophorone                 | ND | 1330 | 1120 | 84 | 1330 | 1090 | 82 | 3 | 45-110 | 50 |
| Naphthalene                | ND | 1330 | 932  | 70 | 1330 | 907  | 68 | 3 | 40-105 | 50 |
| Nitrobenzene               | ND | 1330 | 964  | 72 | 1330 | 951  | 71 | 1 | 40-115 | 50 |
| N-Nitrosodimethylamine     | ND | 1330 | 1050 | 78 | 1330 | 1040 | 78 | 0 | 20-115 | 50 |
| n-Nitroso-di-n-propylamine | ND | 1330 | 1070 | 80 | 1330 | 1050 | 79 | 2 | 40-115 | 50 |
| n-Nitrosodiphenylamine     | ND | 1330 | 1220 | 91 | 1330 | 1160 | 87 | 5 | 50-115 | 50 |
| Pentachlorophenol          | ND | 1330 | 1010 | 75 | 1330 | 975  | 73 | 3 | 25-120 | 50 |
| Phenanthrene               | ND | 1330 | 1150 | 86 | 1330 | 1080 | 81 | 6 | 50-110 | 50 |
| Phenol                     | ND | 1330 | 1120 | 84 | 1330 | 1070 | 80 | 4 | 40-100 | 50 |
| Pyrene                     | ND | 1330 | 1120 | 84 | 1330 | 1050 | 79 | 6 | 45-125 | 50 |
| Benzidine                  | ND | 2670 | 1450 | 54 | 2670 | 1390 | 52 | 4 | 30-150 | 50 |
| 2,6-Dichlorophenol         | ND | 1330 | 1020 | 77 | 1330 | 1010 | 76 | 1 | 10-150 | 50 |

| SURROGATE PARAMETER  | SPIKE AMT<br>(ug/kg) | BS RSLT<br>(ug/kg) | BS<br>% REC | SPIKE AMT<br>(ug/kg) | BSD RSLT<br>(ug/kg) | BSD<br>% REC | QC LIMIT<br>( % ) |
|----------------------|----------------------|--------------------|-------------|----------------------|---------------------|--------------|-------------------|
| 2,4,6-Tribromophenol | 2000                 | 2110               | 105         | 2000                 | 2030                | 101          | 35-125            |
| 2-Fluorobiphenyl     | 667                  | 543                | 81          | 667                  | 545                 | 82           | 45-105            |
| 2-Fluorophenol       | 2000                 | 1640               | 82          | 2000                 | 1620                | 81           | 35-105            |
| Nitrobenzene-d5      | 667                  | 532                | 80          | 667                  | 534                 | 80           | 35-100            |
| Phenol-d5            | 2000                 | 1740               | 87          | 2000                 | 1690                | 84           | 40-100            |
| Terphenyl-d14        | 667                  | 684                | 103         | 667                  | 669                 | 100          | 30-125            |

Figure 10:

## TYPICAL MS/MSD SUMMARY

EMAX QUALITY CONTROL DATA  
MS/MSD ANALYSIS

CLIENT: XYZ, INC.  
PROJECT: CLEAN PROJECT  
BATCH NO.: 14F050  
METHOD: SW35508/8270C

MATRIX: SOIL % MOISTURE: 21.5  
DILUTION FACTOR: 1 1  
SAMPLE ID: 507-DR-SO-011  
LAB SAMP ID: F050-12 F050-12M F050-12S  
LAB FILE ID: RFH297 RFH282 RFH283  
DATE EXTRACTED: 06/19/1412:14 06/19/1412:14 06/19/1412:14 DATE COLLECTED: 06/09/14  
DATE ANALYZED: 06/19/1421:17 06/19/1416:26 06/19/1416:46 DATE RECEIVED: 06/10/14  
PREP. BATCH: SVF0315 SVF0315 SVF0315  
CALIB. REF: RDH120 RDH120 RDH120

## ACCESSION:

| PARAMETER                    | SPL RSLT<br>(ug/kg) | SPIKE AMT<br>(ug/kg) | MS RSLT<br>(ug/kg) | MS<br>% REC | SPIKE AMT<br>(ug/kg) | MSD RSLT<br>(ug/kg) | MSD<br>% REC | RPD<br>( % ) | QC LIMIT<br>( % ) | MAX RPD<br>( % ) |
|------------------------------|---------------------|----------------------|--------------------|-------------|----------------------|---------------------|--------------|--------------|-------------------|------------------|
| 1,2,4-Trichlorobenzene       | ND                  | 1700                 | 1120               | 66          | 1700                 | 1130                | 67           | 1            | 45-110            | 50               |
| 1,2-Dichlorobenzene          | ND                  | 1700                 | 1170               | 69          | 1700                 | 1190                | 70           | 1            | 45-100            | 50               |
| 1,2-Diphenylhydrazine        | ND                  | 1700                 | 1370               | 81          | 1700                 | 1420                | 84           | 4            | 30-130            | 50               |
| 1,3-Dichlorobenzene          | ND                  | 1700                 | 1160               | 69          | 1700                 | 1180                | 69           | 1            | 40-100            | 50               |
| 1,4-Dichlorobenzene          | ND                  | 1700                 | 1180               | 69          | 1700                 | 1170                | 69           | 1            | 35-105            | 50               |
| 2,4,5-Trichlorophenol        | ND                  | 1700                 | 1340               | 79          | 1700                 | 1400                | 82           | 4            | 50-110            | 50               |
| 2,4,6-Trichlorophenol        | ND                  | 1700                 | 1510               | 89          | 1700                 | 1560                | 92           | 3            | 45-110            | 50               |
| 2,4-Dichlorophenol           | ND                  | 1700                 | 1370               | 81          | 1700                 | 1430                | 84           | 4            | 45-110            | 50               |
| 2,4-Dimethylphenol           | ND                  | 1700                 | 1370               | 81          | 1700                 | 1410                | 83           | 3            | 30-105            | 50               |
| 2,4-Dinitrophenol            | ND                  | 1700                 | 1330               | 79          | 1700                 | 1310                | 77           | 2            | 15-130            | 50               |
| 2,4-Dinitrotoluene           | ND                  | 1700                 | 1450               | 85          | 1700                 | 1480                | 87           | 2            | 50-115            | 50               |
| 2,6-Dinitrotoluene           | ND                  | 1700                 | 1370               | 80          | 1700                 | 1430                | 84           | 5            | 50-110            | 50               |
| 2-Chloronaphthalene          | ND                  | 1700                 | 1350               | 79          | 1700                 | 1400                | 82           | 4            | 45-105            | 50               |
| 2-Chlorophenol               | ND                  | 1700                 | 1300               | 77          | 1700                 | 1330                | 78           | 2            | 45-105            | 50               |
| 2-Methylnaphthalene          | ND                  | 1700                 | 1180               | 70          | 1700                 | 1220                | 72           | 3            | 45-105            | 50               |
| 2-Methylphenol               | ND                  | 1700                 | 1180               | 69          | 1700                 | 1190                | 70           | 1            | 40-105            | 50               |
| 2-Nitroaniline               | ND                  | 1700                 | 1410               | 83          | 1700                 | 1440                | 85           | 2            | 45-120            | 50               |
| 2-Nitrophenol                | ND                  | 1700                 | 1390               | 82          | 1700                 | 1440                | 85           | 4            | 40-110            | 50               |
| 3,3'-Dichlorobenzidine       | ND                  | 1700                 | 1470               | 86          | 1700                 | 1570                | 92           | 7            | 10-130            | 50               |
| 4-Methylphenol               | ND                  | 1700                 | 1380               | 81          | 1700                 | 1300                | 76           | 6            | 40-105            | 50               |
| 3-Nitroaniline               | ND                  | 1700                 | 1400               | 82          | 1700                 | 1450                | 86           | 4            | 25-110            | 50               |
| 4,6-Dinitro-2-Methylphenol   | ND                  | 1700                 | 1770               | 104         | 1700                 | 1850                | 109          | 5            | 30-135            | 50               |
| 4-Bromophenyl-phenyl ether   | ND                  | 1700                 | 1500               | 88          | 1700                 | 1590                | 93           | 6            | 45-115            | 50               |
| 4-Chloro-3-Methylphenol      | ND                  | 1700                 | 1520               | 89          | 1700                 | 1540                | 91           | 1            | 45-115            | 50               |
| 4-Chloroaniline              | ND                  | 1700                 | 1160               | 68          | 1700                 | 1210                | 71           | 4            | 10-100            | 50               |
| 4-Chlorophenyl-phenyl ether  | ND                  | 1700                 | 1330               | 78          | 1700                 | 1370                | 81           | 3            | 45-110            | 50               |
| 4-Nitroaniline               | ND                  | 1700                 | 1190               | 70          | 1700                 | 1270                | 75           | 6            | 35-115            | 50               |
| 4-Nitrophenol                | ND                  | 1700                 | 1180               | 69          | 1700                 | 1220                | 72           | 3            | 15-140            | 50               |
| Acenaphthene                 | ND                  | 1700                 | 1370               | 81          | 1700                 | 1410                | 83           | 3            | 45-110            | 50               |
| Acenaphthylene               | ND                  | 1700                 | 1370               | 80          | 1700                 | 1430                | 84           | 4            | 45-105            | 50               |
| Anthracene                   | ND                  | 1700                 | 1390               | 82          | 1700                 | 1470                | 87           | 6            | 55-105            | 50               |
| Benzo(a)anthracene           | ND                  | 1700                 | 1360               | 80          | 1700                 | 1420                | 84           | 5            | 50-110            | 50               |
| Benzo(a)pyrene               | ND                  | 1700                 | 1390               | 82          | 1700                 | 1480                | 87           | 7            | 50-110            | 50               |
| Benzo(b)fluoranthene         | ND                  | 1700                 | 1410               | 83          | 1700                 | 1560                | 92           | 10           | 45-115            | 50               |
| Benzo(g,h,i)perylene         | ND                  | 1700                 | 1380               | 81          | 1700                 | 1430                | 84           | 4            | 40-125            | 50               |
| Benzo(k)fluoranthene         | ND                  | 1700                 | 1390               | 82          | 1700                 | 1380                | 81           | 1            | 45-125            | 50               |
| Benzoic Acid                 | ND                  | 3400                 | 15300              | 45          | 3400                 | 1870                | 55           | 20           | 0-110             | 50               |
| Benzyl Alcohol               | ND                  | 1700                 | 1180               | 69          | 1700                 | 1180                | 69           | 0            | 20-125            | 50               |
| 2,2'-oxybis(1-chloropropane) | ND                  | 1700                 | 1350               | 79          | 1700                 | 1360                | 80           | 1            | 20-115            | 50               |
| bis(2-Chloroethoxy)methane   | ND                  | 1700                 | 1260               | 74          | 1700                 | 1300                | 77           | 4            | 45-110            | 50               |
| bis(2-Chloroethyl)ether      | ND                  | 1700                 | 1190               | 70          | 1700                 | 1230                | 73           | 3            | 40-105            | 50               |
| bis(2-Ethylhexyl)phthalate   | ND                  | 1700                 | 1400               | 82          | 1700                 | 1520                | 89           | 8            | 45-125            | 50               |
| Butylbenzylphthalate         | ND                  | 1700                 | 1400               | 82          | 1700                 | 1510                | 89           | 8            | 50-125            | 50               |
| Carbazole                    | ND                  | 1700                 | 1340               | 79          | 1700                 | 1450                | 85           | 8            | 45-115            | 50               |
| Chrysene                     | ND                  | 1700                 | 1340               | 79          | 1700                 | 1430                | 84           | 6            | 55-110            | 50               |
| Dibenzo(a,h)anthracene       | ND                  | 1700                 | 1420               | 84          | 1700                 | 1510                | 89           | 6            | 40-125            | 50               |
| Dibenzofuran                 | ND                  | 1700                 | 1420               | 84          | 1700                 | 1470                | 87           | 3            | 50-105            | 50               |
| Diethylphthalate             | ND                  | 1700                 | 1390               | 82          | 1700                 | 1450                | 85           | 4            | 50-115            | 50               |
| Dimethylphthalate            | ND                  | 1700                 | 1210               | 71          | 1700                 | 1240                | 73           | 3            | 50-110            | 50               |
| Di-n-butylphthalate          | ND                  | 1700                 | 1470               | 87          | 1700                 | 1620                | 96           | 10           | 55-110            | 50               |
| Di-n-octylphthalate          | ND                  | 1700                 | 1400               | 83          | 1700                 | 1470                | 86           | 5            | 40-130            | 50               |
| Fluoranthene                 | ND                  | 1700                 | 1380               | 81          | 1700                 | 1470                | 87           | 6            | 55-115            | 50               |
| Fluorene                     | ND                  | 1700                 | 1340               | 79          | 1700                 | 1390                | 82           | 3            | 50-110            | 50               |

Figure 10 (cont.):

## TYPICAL MS/MSD SUMMARY

|                            |    |      |       |    |      |       |     |    |        |    |
|----------------------------|----|------|-------|----|------|-------|-----|----|--------|----|
| Hexachlorobenzene          | ND | 1700 | 1500  | 89 | 1700 | 1600  | 94  | 6  | 45-120 | 50 |
| Hexachlorobutadiene        | ND | 1700 | 1050  | 62 | 1700 | 1050  | 62  | 1  | 40-115 | 50 |
| Hexachloroethane           | ND | 1700 | 1390  | 82 | 1700 | 1180  | 70  | 16 | 35-110 | 50 |
| Indeno(1,2,3-cd)pyrene     | ND | 1700 | 1370  | 81 | 1700 | 1460  | 86  | 6  | 40-120 | 50 |
| Isophorone                 | ND | 1700 | 1350  | 80 | 1700 | 1250  | 74  | 8  | 45-110 | 50 |
| Naphthalene                | ND | 1700 | 1160  | 68 | 1700 | 1170  | 69  | 1  | 40-105 | 50 |
| Nitrobenzene               | ND | 1700 | 1190  | 70 | 1700 | 1200  | 71  | 1  | 40-115 | 50 |
| N-Nitrosodimethylamine     | ND | 1700 | 1270  | 75 | 1700 | 1250  | 74  | 1  | 20-115 | 50 |
| n-Nitroso-di-n-propylamine | ND | 1700 | 1290  | 76 | 1700 | 1320  | 78  | 2  | 40-115 | 50 |
| n-Nitrosodiphenylamine     | ND | 1700 | 1660  | 97 | 1700 | 1720  | 101 | 4  | 50-115 | 50 |
| Pentachlorophenol          | ND | 1700 | 1360  | 80 | 1700 | 1470  | 87  | 8  | 25-120 | 50 |
| Phenanthrene               | ND | 1700 | 1430  | 84 | 1700 | 1530  | 90  | 7  | 50-110 | 50 |
| Phenol                     | ND | 1700 | 1360  | 80 | 1700 | 1370  | 81  | 1  | 40-100 | 50 |
| Pyrene                     | ND | 1700 | 1240  | 73 | 1700 | 1330  | 78  | 7  | 45-125 | 50 |
| Benzidine                  | ND | 3400 | 1260J | 37 | 3400 | 1210J | 36  | 4  | 30-150 | 50 |
| 2,6-Dichlorophenol         | ND | 1700 | 1250  | 74 | 1700 | 1310  | 77  | 4  | 10-150 | 50 |

| SURROGATE PARAMETER  | SPIKE AMT<br>(ug/kg) | MS RSLT<br>(ug/kg) | MS<br>% REC | SPIKE AMT<br>(ug/kg) | MSD RSLT<br>(ug/kg) | MSD<br>% REC | QC LIMIT<br>( % ) |
|----------------------|----------------------|--------------------|-------------|----------------------|---------------------|--------------|-------------------|
| 2,4,6-Tribromophenol | 2550                 | 2730               | 107         | 2550                 | 2930                | 115          | 35-125            |
| 2-Fluorobiphenyl     | 849                  | 724                | 85          | 849                  | 752                 | 89           | 45-105            |
| 2-Fluorophenol       | 2550                 | 1930               | 76          | 2550                 | 1940                | 76           | 35-105            |
| Nitrobenzene-d5      | 849                  | 659                | 78          | 849                  | 668                 | 79           | 35-100            |
| Phenol-d5            | 2550                 | 2070               | 81          | 2550                 | 2100                | 82           | 40-100            |
| Terphenyl-d14        | 849                  | 831                | 98          | 849                  | 808                 | 95           | 30-125            |

**Figure 11: TYPICAL CASE NARRATIVE**

---

CASE NARRATIVE

Client : XYZ, INC.  
Project : CLEAN PROJECT  
SDG : 14F050

METHOD SW3550B/8270C  
SEMI VOLATILE ORGANICS BY GC/MS

A total of nineteen (19) soil samples were received on 06/10/14 for Semivolatile Organics by GC/MS analysis, Method SW3550B/8270C in accordance with Project QAPP, 2/2013.

Holding Time

Samples were analyzed within the prescribed holding time.

Instrument Performance and Calibration

Instrument tune check was performed prior to calibration. Instrument mass ratios as well as DDT breakdown were evaluated. Results were within acceptance criteria. Tailing factor for Benzidine and Pentachlorophenol were also verified and results were within the method limits. Multi-calibration points were generated to establish initial calibration (ICAL). ICAL was verified using secondary source (ICV). Continuing calibration (CCV) was carried on at a frequency required by the project. All project calibration requirements were satisfied. Refer to calibration summary forms of ICAL, ICV and CCV for details.

Method Blank

Method blank was analyzed at the frequency required by the project. For this SDG, one method blank was analyzed with the samples. Results were compliant to project requirement.

Lab Control Sample

Two (2) sets of LCS/LCD were analyzed with the samples in this SDG. Percent recoveries for SVF031SL/C were all within QC limits. Percent recoveries for A9F031SL/C were all within QC limits.

Matrix QC Sample

A set of MS/MSD was analyzed with the samples in this SDG. Percent recoveries for F050-12M/S were within project QC limits.

Surrogate

Surrogates were added on QC and field samples. Surrogate recoveries were within project QC limits. Refer to sample result forms for details.

Sample Analysis

Samples were analyzed according to prescribed analytical procedures. All project requirements were met; otherwise, anomalies were discussed within the associated QC parameter. Sample F050-14 was initially analyzed at dilution due to dark-colored appearance in extract.

Appendix 1:

SUMMARY OF QUALITY CONTROL PROCEDURES

| QC PROCEDURE  | FREQUENCY   | ACCEPTANCE CRITERIA   | CORRECTIVE ACTION  | 1st Rvw      | 2nd Rvw |
|---|---|---|--|--------------|---------|
| DFTPP Tune Check  | Prior to calibration (ICAL, ICV or CCV)                           | Refer to Table 7.   | Re-tune instrument and verify.   |              |         |
| Breakdown Check   | Prior to calibration (ICAL, ICV or CCV)                           | Degradation $\leq$ 20% for DDT.<br>Benzidine and pentachlorophenol should be present at their normal responses, Benzidine tailing $\leq$ 3, Pentachlorophenol tailing $<$ 5.  | Clean the injection port and repeat breakdown check. If problem persists, cut or replace column.   |              |         |
| Multi point Initial Calibration (ICAL) minimum of 5 points  | Initially; as needed.   | SPCCs (Table 11): Average RF $\geq$ 0.05<br>CCCs (Table 10): RSD $\leq$ 30%<br>1.) If RRF is applied, then RSD $\leq$ 15%<br>2.) If 1 <sup>st</sup> order is applied, then $r \geq$ 0.995 with min. 5 pt ICAL<br>3.) if 2 <sup>nd</sup> order is applied, then COD $\geq$ 0.99 with min 6 pt ICAL | Check for outliers. Otherwise, optimize the instrument then repeat initial calibration.  |              |         |
| Initial Calibration Verification (ICV)  | After initial calibration   | All analytes within $\pm$ 20% of expected value.<br>* Exclusions Analytes within 35% of expected value.<br>Height of valley between benzo(b)fluoranthene & benzo(k)fluoranthene is less than 25% of the sum of the two peak heights.  | Verify second source standard. Prepare fresh standard and re-run ICV. If that fails, optimize instrument and repeat ICAL.  |              |         |
| Evaluation of Relative Retention Times (RRT)  | Each sample   | Within $\pm$ 0.06 RRT units of the RRT  | Correct the problem then re-analyze all samples analyzed since the last retention time check.  |              |         |
| Continuing Calibration Verification (CCV)   | Daily, before sample analysis and every 12 hours of analysis time | SPCCs: Min. RF same as ICAL<br>CCCs: %Diff $\leq$ 20% (when using RFs) or drift (when using least squares regression or non-linear calibration)<br>Height of valley between benzo(b)fluoranthene & benzo(k)fluoranthene is less than 25% of the sum of the two peak heights.                      | Correct the problem, then repeat initial calibration.  |              |         |
| Internal Standard (IS)  | Every sample, spiked sample, standard, and method blank           | Retention time $\pm$ 30 seconds from retention time of the mid-point standard in the ICAL;<br>EICP area within -50% to +100% of ICAL mid-point standard   | Inspect mass spectrometer and GC for malfunction; mandatory re-analysis of samples analyzed while system was malfunctioning.   |              |         |
| Method Blank (MB)   | One per preparation batch   | In the absence of PSR apply<br>No analytes detected $>$ $\frac{1}{2}$ LOQ   | Rule-out instrument contamination by re-analyzing the MB. If problem persists, refer to PSR. In the absence of PSR, report NDs and results $>$ 10X of the MB concentration. Otherwise, cure contamination source, re-prepare and re-analyze method blank and all associated samples. |              |         |
| LCS   | One LCS per preparation batch                                     | In the absence of PSR default to EMAX QC Limits   | Re-prepare and re-analyze the LCS and all associated samples.  |              |         |
| MS/MSD  | One MS/MSD per every 20 project samples per matrix                | In the absence of PSR default to EMAX QC Limits   | Check is sample was properly spiked. If indicative of matrix interference, discuss in the case narrative, otherwise re-prepare and re-analyze the sample.  |              |         |
| Surrogate spike   | Every sample, MB, LCS, MS/MSD, DCC                                | In the absence of PSR, at least 2 out of 3 Acids and 2 out of 3 BN surrogates are within EMAX QC Limits.  | Check is sample was properly spiked. If indicative of matrix interference, discuss in the case narrative, otherwise re-prepare and re-analyze the sample.  |              |         |
| <b>Comments:</b> For flagging criteria refer to PSR. Otherwise, if MB is non-compliant, apply "B" to specific analyte(s) on all associated samples, apply "J" to all values between LOD and LOQ.<br>*Exception Analytes – Analytes known to have erratic chromatographic behavior: Benzidine, 4,6-dinitro-2methylphenol, 4-chloroaniline, benzyl alcohol, n-Nitrosodimethylamine, 4-nitrophenol, 2-nitroaniline, pyridine, benzoic acid and 3-nitroaniline. |   |   |  | Reviewed By: |         |
|   |   |   |  | Date:        |         |

Revision approved by: Caspar Pang 10/26/17  
Caspar Pang, Laboratory Director (Sign/Date)

Kenette Pimentel 10/26/17  
Kenette Pimentel, QA Manager (Sign/Date)

**Appendix 2: DEMONSTRATION OF CAPABILITY**

**DEMONSTRATION OF CAPABILITY  
METHOD: EPA 8270**

Sample Prep SOP: EMAX-3550 Rev. 4  
Analytical SOP: EMAX-8270 Rev. 5  
Conc Unit: µg/kg  
Sample Amt(g): 15  
Extract Volume (mL): 2

Instrument ID: E7  
Extraction date: 3/22 & 3/24/14  
Extracted by: J. Villena  
Analysis date: 3/24/2014  
Analyzed by: D. Jun

| PARAMETER                   | SVC041SL | SVC041SC | SVC042SL | SVC042SC | TV   | Ave. Conc. | Ave. %Rec | SD    | QC Criteria | COMMENTS |
|-----------------------------|----------|----------|----------|----------|------|------------|-----------|-------|-------------|----------|
|                             | RCH420   | RCH421   | RCH422   | RCH423   |      |            |           |       |             |          |
| Acenaphthene                | 2218     | 2120     | 2086     | 1995     | 2667 | 2105       | 79        | 92.0  | 50 - 130    | PASSED   |
| Acenaphthylene              | 2284     | 2197     | 2166     | 2127     | 2667 | 2194       | 82        | 66.8  | 50 - 130    | PASSED   |
| Aniline                     | 2315     | 2090     | 2115     | 2086     | 2667 | 2152       | 81        | 109.5 | 40 - 130    | PASSED   |
| Anthracene                  | 2242     | 2117     | 2117     | 2034     | 2667 | 2128       | 80        | 86.0  | 50 - 130    | PASSED   |
| Azobenzene                  | 2095     | 1960     | 1906     | 1873     | 2667 | 1958       | 73        | 97.9  | 30 - 160    | PASSED   |
| Benzidine                   | 1865     | 1743     | 1869     | 1716     | 2667 | 1798       | 67        | 80.4  | 20 - 130    | PASSED   |
| Benzo(a)anthracene          | 2620     | 2534     | 2556     | 2506     | 2667 | 2554       | 96        | 48.7  | 60 - 130    | PASSED   |
| benzo(a)pyrene              | 2478     | 2411     | 2481     | 2392     | 2667 | 2440       | 92        | 45.8  | 50 - 130    | PASSED   |
| Benzo(b)fluoranthene        | 2660     | 2560     | 2457     | 2403     | 2667 | 2520       | 94        | 113.8 | 60 - 130    | PASSED   |
| Benzo(g,h,i)perylene        | 2505     | 2378     | 2659     | 2356     | 2667 | 2475       | 93        | 139.3 | 50 - 130    | PASSED   |
| Benzo(k)fluoranthene        | 2327     | 2322     | 2510     | 2366     | 2667 | 2381       | 89        | 88.0  | 60 - 130    | PASSED   |
| Benzoic Acid                | 1116     | 1090     | 1330     | 1206     | 2667 | 1185       | 44        | 108.3 | 20 - 130    | PASSED   |
| Benzyl Alcohol              | 2144     | 1857     | 1920     | 1977     | 2667 | 1975       | 74        | 123.3 | 50 - 130    | PASSED   |
| bis(2-chloroethoxy)methane  | 2354     | 2119     | 2139     | 1997     | 2667 | 2152       | 81        | 148.4 | 50 - 130    | PASSED   |
| bis(2-chloroethyl)ether     | 2160     | 2073     | 2073     | 2011     | 2667 | 2079       | 78        | 61.4  | 50 - 130    | PASSED   |
| bis(2-chloroisopropyl)ether | 2962     | 2690     | 2732     | 2679     | 2667 | 2766       | 104       | 132.9 | 30 - 130    | PASSED   |
| bis(2-Ethylhexyl)phthalate  | 2547     | 2411     | 2442     | 2391     | 2667 | 2448       | 92        | 69.5  | 60 - 130    | PASSED   |
| 4-Bromophenyl-phenylether   | 2274     | 2232     | 2179     | 2101     | 2667 | 2197       | 82        | 74.5  | 50 - 130    | PASSED   |
| Butylbenzylphthalate        | 2715     | 2587     | 2617     | 2524     | 2667 | 2611       | 98        | 79.4  | 60 - 130    | PASSED   |
| Carbazole                   | 2472     | 2345     | 2381     | 2296     | 2667 | 2373       | 89        | 74.4  | 50 - 130    | PASSED   |
| 4-Chloro-3-methylphenol     | 2623     | 2485     | 2427     | 2239     | 2667 | 2443       | 92        | 159.5 | 50 - 130    | PASSED   |
| 4-Chloroaniline             | 2273     | 2046     | 2002     | 1981     | 2667 | 2076       | 78        | 134.3 | 40 - 130    | PASSED   |
| 2-Chloronaphthalene         | 2181     | 2071     | 2016     | 1972     | 2667 | 2060       | 77        | 90.5  | 50 - 130    | PASSED   |
| 2-Chlorophenol              | 2202     | 1982     | 1992     | 2007     | 2667 | 2046       | 77        | 104.4 | 40 - 130    | PASSED   |
| 4-Chlorophenyl-phenylether  | 2357     | 2305     | 2263     | 2185     | 2667 | 2278       | 85        | 72.7  | 50 - 130    | PASSED   |
| Chrysene                    | 2707     | 2564     | 2572     | 2496     | 2667 | 2585       | 97        | 88.1  | 60 - 130    | PASSED   |
| Dibenzo(a,h)anthracene      | 2578     | 2466     | 2529     | 2447     | 2667 | 2505       | 94        | 60.1  | 60 - 130    | PASSED   |
| Dibenzofuran                | 2256     | 2126     | 2080     | 2037     | 2667 | 2125       | 80        | 95.1  | 50 - 130    | PASSED   |
| 1,2-Dichlorobenzene         | 2165     | 1986     | 2030     | 2062     | 2667 | 2061       | 77        | 76.1  | 50 - 130    | PASSED   |
| 1,3-Dichlorobenzene         | 2224     | 2011     | 2130     | 2076     | 2667 | 2110       | 79        | 90.4  | 50 - 130    | PASSED   |
| 1,4-Dichlorobenzene         | 2198     | 1983     | 2104     | 2025     | 2667 | 2077       | 78        | 94.5  | 40 - 130    | PASSED   |
| 3,3'-Dichlorobenzidine      | 2972     | 2745     | 2853     | 2746     | 2667 | 2829       | 106       | 107.8 | 60 - 130    | PASSED   |
| 2,4-Dichlorophenol          | 2219     | 2044     | 2038     | 1929     | 2667 | 2058       | 77        | 120.1 | 40 - 130    | PASSED   |
| 2,6-Dichlorophenol          | 2343     | 2146     | 2232     | 2037     | 2667 | 2190       | 82        | 129.7 | 30 - 160    | PASSED   |
| Diethylphthalate            | 2338     | 2210     | 2217     | 2111     | 2667 | 2219       | 83        | 92.6  | 60 - 130    | PASSED   |
| 2,4-Dimethylphenol          | 2259     | 2028     | 2021     | 1972     | 2667 | 2070       | 78        | 128.7 | 40 - 130    | PASSED   |
| Dimethylphthalate           | 2804     | 2661     | 2565     | 2458     | 2667 | 2622       | 98        | 147.0 | 60 - 130    | PASSED   |
| Di-n-butylphthalate         | 2317     | 2189     | 2268     | 2143     | 2667 | 2229       | 84        | 78.0  | 60 - 130    | PASSED   |
| 4,6-Dinitro-2-methylphenol  | 2332     | 2126     | 2224     | 2260     | 2667 | 2236       | 84        | 85.7  | 50 - 140    | PASSED   |
| 2,4-Dinitrophenol           | 2325     | 2218     | 2275     | 2177     | 2667 | 2249       | 84        | 64.6  | 20 - 130    | PASSED   |

**Appendix 2 (cont.): DEMONSTRATION OF CAPABILITY**

**DEMONSTRATION OF CAPABILITY  
METHOD: EPA 8270**

Sample Prep SOP: EMAX-3550 Rev. 4  
Analytical SOP: EMAX-8270 Rev. 5  
Conc Unit: µg/kg  
Sample Amt(g): 15  
Extract Volume (mL): 2

Instrument ID: E7  
Extraction date: 3/22 & 3/24/14  
Extracted by: J. Villena  
Analysis date: 3/24/2014  
Analyzed by: D. Jun

| PARAMETER                  | SVC0415L | SVC0415C | SVC0425L | SVC0425C | TV   | Ave. Conc. | Ave. %Rec | SD    | QC Criteria | COMMENTS |
|----------------------------|----------|----------|----------|----------|------|------------|-----------|-------|-------------|----------|
|                            | RCH420   | RCH421   | RCH422   | RCH423   |      |            |           |       |             |          |
| 2,4-Dinitrotoluene         | 2590     | 2285     | 2381     | 2342     | 2667 | 2400       | 90        | 132.7 | 60 - 130    | PASSED   |
| 2,6-Dinitrotoluene         | 2386     | 2378     | 2246     | 2237     | 2667 | 2312       | 87        | 81.4  | 60 - 130    | PASSED   |
| Di-n-octylphthalate        | 2775     | 2698     | 2799     | 2631     | 2667 | 2726       | 102       | 76.5  | 60 - 130    | PASSED   |
| Fluoranthene               | 2577     | 2483     | 2519     | 2332     | 2667 | 2478       | 93        | 104.4 | 60 - 130    | PASSED   |
| Fluorene                   | 2203     | 2125     | 2036     | 2023     | 2667 | 2097       | 79        | 84.1  | 50 - 130    | PASSED   |
| Hexachlorobenzene          | 2174     | 1969     | 2021     | 1918     | 2667 | 2020       | 76        | 110.5 | 50 - 130    | PASSED   |
| Hexachlorobutadiene        | 2263     | 2073     | 2072     | 2043     | 2667 | 2113       | 79        | 101.5 | 40 - 130    | PASSED   |
| Hexachlorocyclopentadiene  | 1704     | 1651     | 1573     | 1575     | 2667 | 1626       | 61        | 63.8  | 20 - 130    | PASSED   |
| Hexachloroethane           | 2251     | 2071     | 2102     | 2082     | 2667 | 2127       | 80        | 84.0  | 40 - 130    | PASSED   |
| Indeno(1,2,3-cd)pyrene     | 2498     | 2420     | 2495     | 2372     | 2667 | 2446       | 92        | 61.1  | 60 - 130    | PASSED   |
| Isophorone                 | 2087     | 1949     | 1960     | 1865     | 2667 | 1966       | 74        | 91.5  | 50 - 130    | PASSED   |
| 1-Methylnaphthalene        | 2389     | 2178     | 2176     | 2101     | 2667 | 2211       | 83        | 123.9 | 50 - 130    | PASSED   |
| 2-Methylnaphthalene        | 2689     | 2520     | 2428     | 2406     | 2667 | 2511       | 94        | 128.8 | 50 - 130    | PASSED   |
| 2-Methylphenol             | 2222     | 1996     | 2076     | 1972     | 2667 | 2066       | 77        | 113.0 | 50 - 130    | PASSED   |
| 4-Methylphenol             | 2298     | 2289     | 2267     | 2066     | 2667 | 2230       | 84        | 109.9 | 50 - 130    | PASSED   |
| Naphthalene                | 2208     | 2000     | 2030     | 1977     | 2667 | 2054       | 77        | 105.0 | 50 - 130    | PASSED   |
| 2-Nitroaniline             | 2616     | 2515     | 2414     | 2705     | 2667 | 2563       | 96        | 126.0 | 50 - 130    | PASSED   |
| 3-Nitroaniline             | 2503     | 2434     | 2364     | 2253     | 2667 | 2388       | 90        | 106.6 | 50 - 130    | PASSED   |
| 4-Nitroaniline             | 2657     | 2497     | 2560     | 2487     | 2667 | 2550       | 96        | 78.3  | 50 - 130    | PASSED   |
| Nitrobenzene               | 2210     | 2044     | 2027     | 1995     | 2667 | 2069       | 78        | 96.3  | 50 - 130    | PASSED   |
| 2-Nitrophenol              | 2631     | 2520     | 2405     | 2372     | 2667 | 2482       | 93        | 117.9 | 40 - 130    | PASSED   |
| 4-Nitrophenol              | 2333     | 2258     | 2316     | 2303     | 2667 | 2303       | 86        | 32.0  | 40 - 130    | PASSED   |
| n-Nitrosodimethylamine     | 1914     | 1721     | 1784     | 1684     | 2667 | 1776       | 67        | 101.1 | 40 - 130    | PASSED   |
| n-Nitroso-di-n-propylamine | 2214     | 1938     | 1972     | 1933     | 2667 | 2014       | 76        | 134.2 | 50 - 130    | PASSED   |
| n-Nitrosodiphenylamine     | 2324     | 2202     | 2208     | 2221     | 2667 | 2239       | 84        | 57.4  | 40 - 130    | PASSED   |
| Pentachlorophenol          | 2233     | 2091     | 2121     | 2013     | 2667 | 2114       | 79        | 91.5  | 30 - 130    | PASSED   |
| Phenanthrene               | 2216     | 2105     | 2104     | 2030     | 2667 | 2114       | 79        | 76.7  | 50 - 130    | PASSED   |
| Phenol                     | 2125     | 1980     | 2038     | 1906     | 2667 | 2012       | 75        | 92.5  | 50 - 130    | PASSED   |
| Pyrene                     | 2549     | 2398     | 2434     | 2326     | 2667 | 2427       | 91        | 93.1  | 50 - 130    | PASSED   |
| Pyridine                   | 1679     | 1552     | 1668     | 1591     | 2667 | 1623       | 61        | 61.2  | 30 - 130    | PASSED   |
| 2,3,4,6-Tetrachlorophenol  | 2374     | 2214     | 2222     | 2137     | 2667 | 2237       | 84        | 99.4  | 30 - 160    | PASSED   |
| 1,2,4-Trichlorobenzene     | 2199     | 1997     | 2070     | 1968     | 2667 | 2059       | 77        | 102.8 | 40 - 130    | PASSED   |
| 2,4,5-Trichlorophenol      | 2330     | 2223     | 2257     | 2070     | 2667 | 2220       | 83        | 109.8 | 50 - 130    | PASSED   |
| 2,4,6-Trichlorophenol      | 2170     | 2040     | 1988     | 1995     | 2667 | 2048       | 77        | 84.3  | 50 - 130    | PASSED   |
| 2-Fluorophenol             | 3555     | 3234     | 3374     | 3295     | 4000 | 3364       | 84        | 139.2 | 40 - 130    | PASSED   |
| Phenol-d5                  | 3636     | 3338     | 3424     | 3264     | 4000 | 3415       | 85        | 161.0 | 50 - 130    | PASSED   |
| 2-Fluorobiphenyl           | 1122     | 1065     | 1093     | 1052     | 1333 | 1083       | 81        | 31.3  | 40 - 130    | PASSED   |
| Nitrobenzene-d5            | 1136     | 1009     | 1066     | 974      | 1333 | 1046       | 78        | 70.7  | 40 - 130    | PASSED   |
| 2,4,6-Tribromophenol       | 3419     | 3256     | 3355     | 3093     | 4000 | 3281       | 82        | 142.0 | 50 - 130    | PASSED   |
| Terphenyl-d14              | 1489     | 1427     | 1478     | 1453     | 1333 | 1462       | 110       | 27.6  | 60 - 130    | PASSED   |

Appendix 3:

DEMONSTRATION OF CAPABILITY  
FOR APPENDIX IX COMPOUNDS

DEMONSTRATION OF CAPABILITY  
METHOD: SW 3550C / SW 8270C/D  
APPENDIX IX COMPOUNDS

Sample Prep SOP: EMAX-3550  
Analytical SOP: EMAX-8270  
Conc Unit:  $\mu\text{g}/\text{kg}$   
Sample Amt(gm): 30  
Extract Volume (mL): 2

Instrument ID: E4  
Extraction date: 6/24/2011  
Extracted by: J. Villena  
Analysis date: 6/27 & 6/28/11  
Analyzed by: D. Cheung

| PARAMETER                     | RFJ303   | RFJ304   | RFJ343   | RFJ344   | TV   | Ave. Conc. | Ave. %Rec | SD    | RSD (%) | QC Criteria | COMMENTS |
|-------------------------------|----------|----------|----------|----------|------|------------|-----------|-------|---------|-------------|----------|
|                               | A9F0445L | A9F0445C | A9F0455L | A9F0455C |      |            |           |       |         |             |          |
| Acetophenone                  | 1225     | 1231     | 1632     | 1204     | 1600 | 1323       | 83        | 206.5 | 16      | 30 - 150    | PASSED   |
| 2-acetylaminofluorene         | 1433     | 1485     | 1884     | 1669     | 1600 | 1618       | 101       | 204.7 | 13      | 30 - 150    | PASSED   |
| 4-Aminobiphenyl               | 1502     | 1589     | 1895     | 1650     | 1600 | 1659       | 104       | 168.6 | 10      | 30 - 150    | PASSED   |
| Aramite                       | 1526     | 1586     | 2057     | 1770     | 1600 | 1735       | 108       | 238.9 | 14      | 30 - 150    | PASSED   |
| Atrazine                      | 1508     | 1500     | 1858     | 1643     | 1600 | 1627       | 102       | 167.2 | 10      | 30 - 150    | PASSED   |
| Biphenyl                      | 1235     | 1256     | 1600     | 1247     | 1600 | 1334       | 83        | 177.5 | 13      | 30 - 130    | PASSED   |
| Chlorobenzilate               | 1390     | 1454     | 1825     | 1541     | 1600 | 1553       | 97        | 192.1 | 12      | 30 - 150    | PASSED   |
| 1-Chloronaphthalene           | 1266     | 1295     | 1616     | 1277     | 1600 | 1363       | 85        | 168.7 | 12      | 30 - 150    | PASSED   |
| Diallate                      | 1272     | 1303     | 1638     | 1490     | 1600 | 1426       | 89        | 171.3 | 12      | 30 - 150    | PASSED   |
| Dibenzo(a,j)acridine          | 1272     | 1319     | 1660     | 1385     | 1600 | 1409       | 88        | 173.5 | 12      | 30 - 150    | PASSED   |
| 2,6-Dichlorophenol            | 1228     | 1225     | 1633     | 1248     | 1600 | 1334       | 83        | 200.0 | 15      | 30 - 150    | PASSED   |
| Dimethoate                    | 1563     | 1616     | 2017     | 1741     | 1600 | 1734       | 108       | 202.6 | 12      | 30 - 150    | PASSED   |
| p-Dimethylaminoazobenze       | 1374     | 1394     | 1776     | 1544     | 1600 | 1522       | 95        | 185.8 | 12      | 30 - 150    | PASSED   |
| 7,12-Dimethylben(a)anthracene | 1383     | 1428     | 1764     | 1547     | 1600 | 1530       | 96        | 170.5 | 11      | 30 - 150    | PASSED   |
| 3,3-Dimethylbenzidine         | 1383     | 1427     | 988      | 1516     | 1600 | 1329       | 83        | 233.7 | 18      | 10 - 150    | PASSED   |
| 3,4-Dimethylphenol            | 1172     | 1194     | 1610     | 1291     | 1600 | 1317       | 82        | 202.2 | 15      | 30 - 150    | PASSED   |
| Dinoseb                       | 1324     | 1419     | 1836     | 1556     | 1600 | 1534       | 96        | 222.8 | 15      | 30 - 150    | PASSED   |
| 1,4-Dioxane                   | 1097     | 1122     | 1376     | 1041     | 1600 | 1159       | 72        | 148.7 | 13      | 30 - 150    | PASSED   |
| Diphenyl ether                | 1219     | 1237     | 1565     | 1243     | 1600 | 1316       | 82        | 166.2 | 13      | 30 - 150    | PASSED   |
| Disulfoton                    | 1356     | 1414     | 1782     | 1554     | 1600 | 1526       | 95        | 189.7 | 12      | 30 - 150    | PASSED   |
| Ethyl methacrylate            | 1121     | 1170     | 1440     | 1082     | 1600 | 1203       | 75        | 162.0 | 13      | 30 - 150    | PASSED   |
| Ethyl methanesulfonate        | 1217     | 1252     | 1589     | 1202     | 1600 | 1315       | 82        | 184.0 | 14      | 30 - 150    | PASSED   |
| Ethyl parathion               | 1364     | 1445     | 1880     | 1525     | 1600 | 1554       | 97        | 227.6 | 15      | 30 - 150    | PASSED   |
| Hexachloropropene             | 1226     | 1261     | 1578     | 1201     | 1600 | 1317       | 82        | 176.0 | 13      | 30 - 150    | PASSED   |
| Isodrin                       | 1308     | 1276     | 1642     | 1449     | 1600 | 1419       | 89        | 166.5 | 12      | 30 - 150    | PASSED   |
| Isosafrole                    | 1427     | 1445     | 1867     | 1473     | 1600 | 1553       | 97        | 210.5 | 14      | 30 - 150    | PASSED   |
| 3-Methylcholanthrene          | 1407     | 1445     | 1811     | 1579     | 1600 | 1561       | 98        | 182.6 | 12      | 30 - 150    | PASSED   |
| Methyl methanesulfonate       | 1219     | 1216     | 1423     | 1154     | 1600 | 1253       | 78        | 117.3 | 9       | 30 - 150    | PASSED   |
| Methyl parathion              | 1418     | 1509     | 1923     | 1667     | 1600 | 1630       | 102       | 221.1 | 14      | 30 - 150    | PASSED   |
| 1,4-Naphthoquinone            | 1337     | 1376     | 1702     | 1517     | 1600 | 1483       | 93        | 165.3 | 11      | 10 - 150    | PASSED   |
| 1-Naphthylamine               | 1285     | 1288     | 1660     | 1396     | 1600 | 1407       | 88        | 176.1 | 13      | 30 - 150    | PASSED   |
| 2-Naphthylamine               | 1425     | 1418     | 1806     | 1586     | 1600 | 1559       | 97        | 182.3 | 12      | 30 - 150    | PASSED   |
| N-nitrosodiethylamine         | 1207     | 1253     | 1604     | 1202     | 1600 | 1317       | 82        | 192.9 | 15      | 30 - 150    | PASSED   |
| N-Nitrosomethylethylamine     | 1187     | 1252     | 1577     | 1171     | 1600 | 1297       | 81        | 190.0 | 15      | 30 - 150    | PASSED   |
| N-Nitrosomorpholine           | 1206     | 1249     | 1627     | 1210     | 1600 | 1323       | 83        | 203.4 | 15      | 30 - 150    | PASSED   |
| N-Nitrosodi-n-butylamine      | 1263     | 1295     | 1764     | 1399     | 1600 | 1430       | 89        | 230.0 | 16      | 30 - 150    | PASSED   |
| N-Nitrosopiperidine           | 1231     | 1247     | 1647     | 1266     | 1600 | 1348       | 84        | 200.2 | 15      | 30 - 150    | PASSED   |
| N-Nitrosopyrrolidine          | 1194     | 1242     | 1678     | 1267     | 1600 | 1345       | 84        | 224.0 | 17      | 30 - 150    | PASSED   |
| 5-Nitro-o-toluidine           | 1425     | 1465     | 1829     | 1506     | 1600 | 1556       | 97        | 185.0 | 12      | 30 - 150    | PASSED   |
| 4-Nitroquinoline-N-oxide      | 1402     | 1493     | 1737     | 1567     | 1600 | 1550       | 97        | 142.1 | 9       | 10 - 150    | PASSED   |
| Pentachlorobenzene            | 1257     | 1306     | 1656     | 1355     | 1600 | 1393       | 87        | 179.7 | 13      | 30 - 150    | PASSED   |



Appendix 3 (cont.):

DEMONSTRATION OF CAPABILITY  
FOR APPENDIX IX COMPOUNDS

DEMONSTRATION OF CAPABILITY  
METHOD: SW 3550C / SW 8270C/D  
APPENDIX IX COMPOUNDS

Sample Prep SOP: EMAX-3550  
Analytical SOP: EMAX-8270  
Conc Unit: µg/Kg  
Sample Amt(gm): 30  
Extract Volume (mL): 2

Instrument ID: E4  
Extraction date: 6/24/2011  
Extracted by: J. Villena  
Analysis date: 6/27 & 6/28/11  
Analyzed by: D. Cheung

| PARAMETER                   | RFJ303   | RFJ304   | RFJ343   | RFJ344   | TV   | Ave. Conc. | Ave. %Rec | SD    | RSD (%) | QC Criteria | COMMENTS |
|-----------------------------|----------|----------|----------|----------|------|------------|-----------|-------|---------|-------------|----------|
|                             | A9F0445L | A9F0445C | A9F0455L | A9F0455C |      |            |           |       |         |             |          |
| Pentachloroethane           | 1203     | 1195     | 1487     | 1106     | 1600 | 1248       | 78        | 165.2 | 13      | 30 - 150    | PASSED   |
| Pentachloronitrobenzene     | 1354     | 1424     | 1721     | 1553     | 1600 | 1513       | 95        | 161.4 | 11      | 30 - 150    | PASSED   |
| Phenacetin                  | 1476     | 1527     | 1853     | 1585     | 1600 | 1610       | 101       | 167.8 | 10      | 30 - 150    | PASSED   |
| p-phenylenediamine          | 826      | 886      | 1211     | 844      | 1600 | 942        | 59        | 180.9 | 19      | 10 - 150    | PASSED   |
| Phorate                     | 1340     | 1377     | 1752     | 1524     | 1600 | 1498       | 94        | 186.8 | 12      | 30 - 150    | PASSED   |
| 2-Picoline                  | 1036     | 1063     | 1338     | 956      | 1600 | 1098       | 69        | 165.9 | 15      | 10 - 150    | PASSED   |
| pronamide                   | 1456     | 1506     | 1877     | 1625     | 1600 | 1616       | 101       | 187.7 | 12      | 30 - 150    | PASSED   |
| Safrole                     | 1221     | 1263     | 1667     | 1277     | 1600 | 1357       | 85        | 208.0 | 15      | 30 - 150    | PASSED   |
| Sulfotepp                   | 1317     | 1376     | 1723     | 1534     | 1600 | 1487       | 93        | 181.8 | 12      | 30 - 150    | PASSED   |
| 1,2,4,5-Tetrachlorobenzene  | 1233     | 1269     | 1624     | 1246     | 1600 | 1343       | 84        | 187.8 | 14      | 30 - 150    | PASSED   |
| Thionazin                   | 1364     | 1365     | 1809     | 1540     | 1600 | 1520       | 95        | 210.1 | 14      | 30 - 150    | PASSED   |
| o-toluidine                 | 1387     | 1401     | 1769     | 1345     | 1600 | 1475       | 92        | 196.9 | 13      | 30 - 150    | PASSED   |
| O,O,O-triethyl phosphorothi | 1218     | 1230     | 1612     | 1237     | 1600 | 1324       | 83        | 192.2 | 15      | 30 - 150    | PASSED   |
| 1,3,5-Trinitrobenzene       | 1432     | 1566     | 1952     | 1464     | 1600 | 1604       | 100       | 239.1 | 15      | 10 - 150    | PASSED   |
| 2-Fluorophenol              | 1602     | 1611     | 1767     | 1545     | 2000 | 1632       | 82        | 95.0  | 6       | 40 - 130    | PASSED   |
| Pheno-d5                    | 1584     | 1616     | 1876     | 1623     | 2000 | 1675       | 84        | 135.3 | 8       | 50 - 130    | PASSED   |
| Nitrobenzene-d5             | 522      | 519      | 605      | 531      | 667  | 544        | 82        | 40.5  | 7       | 40 - 130    | PASSED   |
| 2-Fluorobiphenyl            | 527      | 534      | 617      | 545      | 667  | 556        | 83        | 41.2  | 7       | 50 - 130    | PASSED   |
| 2,4,6-Tribromophenol        | 1788     | 1860     | 2086     | 2059     | 2000 | 1948       | 97        | 147.2 | 8       | 50 - 130    | PASSED   |
| Terphenyl-d14               | 658      | 678      | 764      | 742      | 667  | 710        | 106       | 50.3  | 7       | 50 - 130    | PASSED   |





8270FA:

ANALYTICAL RUN LOG



ANALYSIS LOG FOR SEMIVOLATILES

SOP  EMAX-8270 Rev. No. \_  EMAX-8270D Rev. No. \_  EMAX-8270SIM Rev. No. \_  EMAX-CLPSVOA  EMAX-M8270SIM Rev. No. \_  EMAX-625 Rev. No. \_

Book #: AF0-002

| Preparative Batch | Data File Name | Run ID | DF | Matrix |   | Notes | Instrument No:                  |  | F0           |
|-------------------|----------------|--------|----|--------|---|-------|---------------------------------|--|--------------|
|                   |                |        |    | S      | W |       |                                 |  |              |
|                   |                |        |    |        |   |       | INITIAL CALIBRATION REFERENCE   |  |              |
|                   |                |        |    |        |   |       | Date                            |  |              |
|                   |                |        |    |        |   |       | ICAL ID                         |  |              |
|                   |                |        |    |        |   |       | Standards                       |  |              |
|                   |                |        |    |        |   |       | Name                            | ID   | Conc. (mg/L) |
|                   |                |        |    |        |   |       | DFTPP                           |  |              |
|                   |                |        |    |        |   |       | INT. STD.                       |  |              |
|                   |                |        |    |        |   |       | ICV                             |  |              |
|                   |                |        |    |        |   |       | DCC                             |  |              |
|                   |                |        |    |        |   |       | BENZIDINE                       |  |              |
|                   |                |        |    |        |   |       | APP 9                           |  |              |
|                   |                |        |    |        |   |       | APP 9 ADD                       |  |              |
|                   |                |        |    |        |   |       |                                 |  |              |
|                   |                |        |    |        |   |       | Solvent                         | ID   |              |
|                   |                |        |    |        |   |       | CH <sub>2</sub> Cl <sub>2</sub> |  |              |
|                   |                |        |    |        |   |       | DATA FILE                       |  |              |
|                   |                |        |    |        |   |       | Electronic Data Archival        |  |              |
|                   |                |        |    |        |   |       | Location                        | Date   |              |
|                   |                |        |    |        |   |       | HPCHEM_SVOA/TOFO                |  |              |
|                   |                |        |    |        |   |       | Micropipette ID:                | <input type="checkbox"/> PO97A-02<br><input type="checkbox"/> PO97A-03<br><input type="checkbox"/> PO00-01 |              |
|                   |                |        |    |        |   |       | Comments:                       |  |              |
|                   |                |        |    |        |   |       | Analyzed By:                    |  |              |
|                   |                |        |    |        |   |       | Date Disposed:                  |  |              |
|                   |                |        |    |        |   |       | Disposed By:                    |  |              |



This page is checked during data review.

ANALYTICAL BATCH : \_\_\_\_\_



## STANDARD OPERATING PROCEDURES

pH, SOLID AND WASTE SAMPLES

|              |   |   |                        |
|--------------|---|---|------------------------|
| SOP No.:     | <u>EMAX-9045</u>                          | Revision No. <u>4</u>   | Date: <u>22-Jun-17</u> |
| Prepared By: | <u>Tyler Kosaka</u>                       |  | Date: <u>06-20-17</u>  |
| Approved By: | <u>Kenette Pimentel</u><br>QA Manager     |  | Date: <u>06-20-17</u>  |
| Approved By: | <u>Caspar Pang</u><br>Laboratory Director |  | Date: <u>06-20-17</u>  |

Control Number: 9045-04-

**1.0 SCOPE AND APPLICATION**

- 1.1. This procedure describes the process of pH determination of soils and waste samples.
- 1.2. This method is an adaptation of USEPA SW846 Method 9045D.

**2.0 SUMMARY OF METHOD**

- 2.1. The sample is mixed with reagent water, and the pH of the resulting aqueous solution is measured.
- 2.2. Interferences
  - 2.2.1. Samples with very low or very high pH may give incorrect readings on the meter. For samples with a true pH of > 10, the measured pH may be incorrectly low. Using a low sodium error electrode can minimize this error. Strong acid solutions, with a true pH of < 1, may give incorrectly high pH measurements.
  - 2.2.2. Temperature fluctuations will cause measurement errors.
  - 2.2.3. Errors will occur when the electrodes become coated. If an electrode becomes coated with an oily material that will not rinse free, the electrode can undergo one of the following procedures:
    - 2.2.3.1. Clean with an ultrasonic bath.
    - 2.2.3.2. Wash with detergent and rinse several times with water. Place in 1:10 HCl so that the lower third of the electrode is submerged and then thoroughly rinse with water.
    - 2.2.3.3. Clean electrode as per manufacturer's instructions.

**3.0 DETECTION LIMITS**

- 3.1. **Detection Limit (DL), Limit of Detection (LOD)**
- 3.2. DL and LOD are not applicable for this method.
- 3.3. **Limit of Quantitation (LOQ)**
  - 3.3.1. Refer to EMAX-QA04 for generation, validation and verification of LOQ.
  - 3.3.2. Established LOQ for this method is 1 pH unit.

## STANDARD OPERATING PROCEDURE

**pH, SOLID AND WASTE SAMPLES**SOP No.: EMAX-9045 Revision No. 4 Date: 22-Jun-17

---

**4.0 DYNAMIC RANGE**

- 4.1. Range: 1 to 14 pH unit

**5.0 SAMPLE PRESERVATION AND HOLDING TIME**

- 5.1. Samples should be analyzed as soon as possible

**6.0 ASSOCIATED SOPs**

- 6.1. EMAX-DM01 Data Flow & Review  
6.2. EMAX-QA04 Detection Limit (DL)  
6.3. EMAX-QA05 Training  
6.4. EMAX-QA08 Corrective Action  
6.5. EMAX-QC01 Quality Control for Chemicals  
6.6. EMAX-QC04 Balance Calibration  
6.7. EMAX-QC05 Calibration of Thermometers  
6.8. EMAX-SM03 Waste Disposal  
6.9. EMAX-SM04 Analytical and QC Sample Labeling

**7.0 SAFETY**

- 7.1. Read all SDS of chemicals and reagents listed in this SOP.  
7.2. Treat reagents, standards, and samples as potential hazards. Observe the standard laboratory safety procedures. Wear protective gear, i.e., lab coat, safety glasses, gloves, at all times when performing this procedure.  
7.3. If for any reason, solvent and/or other reagents get in contact with your skin or any other part of your body, rinse the affected body part thoroughly with tap water. If irritations persist inform your supervisor immediately so that proper action can be taken.

**8.0 INSTRUMENTS, CHEMICALS AND REAGENTS****8.1. Instruments and Supplies**

- 8.1.1. pH Meter – Orion 420A or equivalent  
8.1.2. Combination electrode  
8.1.3. Stirrer – magnetic  
8.1.4. 45-ml hinged lid sample container

**8.2. Chemicals and Reagents**

- 8.2.1. Reagent water: Type II

## STANDARD OPERATING PROCEDURE

**pH, SOLID AND WASTE SAMPLES**SOP No.: EMAX-9045 Revision No. 4 Date: 22-Jun-17

---

8.2.2. pH Electrode Storage Solution

**9.0 STANDARDS****9.1. Primary Standard Buffer: Calibration Buffer Standard**

9.1.1. PH 1.0 - BDH or equivalent

9.1.2. pH 4.0 - BDH or equivalent

9.1.3. pH 7.0 - BDH or equivalent

9.1.4. pH 10.0 - BDH or equivalent

9.1.5. pH 12.45 - BDH or equivalent

**9.2. Secondary Standard Buffer: Calibration Check Standard (second source)**

9.2.1. pH 8.0 - RICCA or equivalent

**10.0 PROCEDURES****10.1. Sample Preparation****10.1.1. Soil Samples**

10.1.1.1. To 20 g of soil in a 50 mL beaker, add 20 mL of reagent water, cover, and continuously stir the suspension for 5 min. Additional dilutions are allowed if working with hygroscopic soils and salts or other problematic matrices.

10.1.1.2. Let the soil suspension stand for about 1 hr to allow most of the suspended clay to settle out from the suspension or filter or centrifuge off the aqueous phase for pH measurement.

10.1.1.3. Place the samples (aqueous phase) in water bath at  $25 \pm 0.4^{\circ}\text{C}$  to equilibrate.**10.1.2. Waste Samples**

10.1.2.1. To 20 g of waste sample in a 50 ml beaker, add 20 ml of reagent water, cover, and continuously stir the suspension for 5 min. Additional dilutions are allowed if working with hygroscopic wastes and salts or other problematic matrices.

10.1.2.2. Let the waste suspension stand for about 15 min. to allow most of the suspended waste to settle out from the suspension or filter or centrifude off aqueous phase for pH measurement.

NOTE: If the waste is hygroscopic and absorbs all the reagent water, begin the experiment again using 20 g of waste and 40 mL of reagent water.

NOTE: If the supernatant is multiphasic, decant the oily phase and measure the pH of the aqueous phase. The electrode may need to be cleaned if it becomes coated with an oily material.

10.1.2.3. Place the samples (aqueous phase) in water bath at  $25 \pm 0.4^{\circ}\text{C}$  to equilibrate.**10.2. Instrument Parameters**



## STANDARD OPERATING PROCEDURE

**pH, SOLID AND WASTE SAMPLES**SOP No.: EMAX-9045 Revision No. 4 Date: 22-Jun-17

---

10.2.1. Refer to instrument operating manual.

**10.3. Calibration****10.3.1. Initial Calibration**

10.3.1.1. Transfer about 10 mL of pH 4 buffer solution into a clean properly labeled 20 mL vial. Similarly, transfer pH 7 and pH 10 buffer solutions.

10.3.1.2. Rinse the pH meter electrode thoroughly with reagent water and shake-off the excess water from the electrode.

10.3.1.3. Calibrate the pH meter according to the instrument-operating manual.

10.3.1.4. Record the calibration readings in the analysis run log.

10.3.1.5. Rinse the pH meter electrode thoroughly with reagent water and shake-off the excess water from the electrode.

NOTE: Different pH points can be used in the calibration depending on the pH of the samples. When a sample is found to be pH < 4.0, include pH 1.0 in the calibration. Likewise, if samples is pH > 10.0, include pH 12.45 in the calibration.

**10.3.2. Calibration Check Standard (Second Source)**

10.3.2.1. Take the pH measurement of a second source standard as described in 10.4.2. Wait until the reading stabilizes. Record the reading.

10.3.2.2. Check Appendix 1 for acceptance criteria.

**10.4. Analysis****10.4.1. Analytical Sequence**

10.4.1.1. Calibration Standards

10.4.1.2. Calibration Check Standard

10.4.1.3. Samples to a maximum of 20

10.4.1.4. Duplicate sample

**10.4.2. pH Measurements**

10.4.2.1. Rinse the pH meter electrode thoroughly with reagent water and shake-off the excess water from the electrode.

10.4.2.2. Rinse the electrode with the sample to be analyzed.

10.4.2.3. Place a clean magnetic stir bar and turn on the stirrer at a medium speed.

10.4.2.4. Immerse the pH electrode into sample just deep enough into clear supernatant solution. Allow the electrode to stabilize for at least 1 minute or until the readout is stable.

10.4.2.5. Record the pH reading and the sample temperature in °C. Report the final pH reading to the nearest 0.01.

**10.5. Calculations**

## STANDARD OPERATING PROCEDURE

**pH, SOLID AND WASTE SAMPLES**

SOP No.: EMAX-9045 Revision No. 4 Date: 22-Jun-17

---

10.5.1. Calculate Difference of Duplicate Samples

$$\text{Difference} = |\text{pH}_1 - \text{pH}_2| \quad \text{Eq.-10.5.1}$$

Where:

$\text{pH}_1$  = pH reading of first measurement

$\text{pH}_2$  = pH reading of second measurement

10.6. **Data Reduction**

- 10.6.1. Print a copy of the run log.
- 10.6.2. Highlight the data to be reported.
- 10.6.3. Keep all other data generated with the analytical folder marked with "For record only".

10.7. **Report Generation**

- 10.7.1. Generate the method.txt file, sample results and QC summaries using PH.exe.
- 10.7.2. Generate the case narrative using CN00.exe.
- 10.7.3. Arrange the analysis package in sequence as detailed below.
  - 10.7.3.1. Case Narrative
  - 10.7.3.2. Sample Results
  - 10.7.3.3. Sample Duplicate Result Summary
  - 10.7.3.4. Run Log
  - 10.7.3.5. Non-Conformance Report (if any)

10.8. **Data Review**

- 10.8.1. Perform a 100% data review in accordance to EMAX-DM01 and the PSR.
  - 10.8.1.1. Review the generated reports against the run log. Check that the analytical data generated indicating positive results are qualitatively and quantitatively correct.
  - 10.8.1.2. Review the case narrative and check that it accurately describes what transpired in the analytical process. Edit as necessary to reflect essential issues not captured by the case narrative generator program.
- 10.8.2. Submit the analytical folder for secondary review.

10.9. **Preventive Maintenance**

- 10.9.1. Rinse the pH electrode every after use and let it rest on the electrode hanger.
- 10.9.2. Instruments should receive routine preventive maintenance, which is reported in instrument-specific maintenance logs. Routine maintenance insures that all equipment are operating under optimum conditions, thus reducing the possibility of instrument malfunction, consequently affecting sample results.

11.0 **QUALITY CONTROL**

## STANDARD OPERATING PROCEDURE

**pH, SOLID AND WASTE SAMPLES**SOP No.: EMAX-9045 Revision No. 4 Date: 22-Jun-17

---

11.1. Acceptance criteria for each quality control procedure are summarized in Appendix 1.

**11.2. Analytical Batch QC**

11.2.1. Always use fresh buffer solutions for calibration.

11.2.2. Check standard is analyzed after the initial calibration, after every 20 field samples and at the end of the analysis sequence.

11.2.3. Rinse electrode thoroughly between measurements.

11.2.4. Reagents are subjected to QC check prior to its use. Refer to EMAX-QC01.

**11.3. Preparation Batch QC**

11.3.1. The maximum number of original field samples in a prep batch is 20 unless otherwise specified by the project.

11.3.2. Properly treat all lab wares used in the sample preparation as specified in EMAX-QC07.

**11.4. Method QC**

11.4.1. All analysts conducting this analysis must demonstrate capability as described in EMAX-QA05.

**12.0 CORRECTIVE ACTIONS**

12.1. Corrective action for each quality control procedure is summarized in Appendix 1

**12.2. Analytical Batch QC**

12.2.1. When calibration is non-compliant, consider the following suggestions to correct the problem:

- Check the electrode is clean and properly installed, verify the pH meter parameter setup and make sure that the electrode is clean.
- Rule out calibration buffer degradation/contamination by using a new calibration buffer.
- If problem persist, replace the electrode fill solution [refer to manufacturer's manual] and repeat the calibration process. Otherwise, inform the Supervisor for further guidance.

**12.3. Preparation Batch QC**

12.3.1. For insufficient amount of sample(s), inform the Supervisor immediately for further action.

12.4. A Non-Conformance Report (NCR) is required when the following circumstances occur:

- Anomalies other than specified in Appendix 1, is observed.
- Sample is out of technical holding time.

12.4.1. Refer to EMAX-QA08 for NCR details.

**13.0 POLLUTION PREVENTION**

13.1. Observe all necessary precautions to avoid spillage of sample and buffer solutions that may go to the wastewater drains.

## STANDARD OPERATING PROCEDURE

**pH, SOLID AND WASTE SAMPLES**SOP No.: EMAX-9045 Revision No. 4 Date: 22-Jun-17

---

**14.0 WASTE MANAGEMENT**

- 14.1. No samples shall be dumped on the laboratory sink.
- 14.2. Separate and properly identify all unused expired analytical standards for proper disposal.
- 14.3. Place all waste generated during analytical process in properly labeled satellite waste containers for proper collection.
- 14.4. Dispose all unused samples, expired analytical standards and other waste generated during the analytical process in accordance to EMAX-SM03.

**15.0 SUPPLEMENTARY NOTES****15.1. Definition of Terms**

- 15.1.1. pH – is the intensity factor of hydrogen ions activity in a solution.
- 15.1.2. Batch – is a group of samples that are prepared and/or analyzed at the same time using the same lot of reagents.
  - 15.1.2.1. **Preparation Batch** – is composed of one to 20 samples of the same matrix, a method blank and a sample duplicate.
  - 15.1.2.2. **Analytical Batch** – is composed of prepared samples (extracts, digestates, or concentrates), which are analyzed together as a group using an instrument in conformance to the analytical requirement. An analytical batch can include samples originating from various matrices, preparation batches, and can exceed 20 samples.
- 15.1.3. Limit of Quantitation (LOQ) – is at the lowest concentration that produces a quantitative result within specified limits of precision and bias. For DoD projects, the LOQ shall be set at or above the concentration of the lowest initial calibration standard.
- 15.1.4. Safety Data Sheet (SDS) – is a written information concerning a chemical physical properties, toxicity, health hazards, fire hazard and reactivity data including storage, spill and handling precautions.
- 15.1.5. Calibration – is a determinant measured from a standard to obtain the correct value of an instrument output.
- 15.1.6. Calibration Check Standard - is a standard purchased from a different vendor at a different concentration from the calibration standards to verify the instrument calibration.
- 15.1.7. Sample – is a specimen received in the laboratory bearing a sample label traceable to the accompanying COC. Samples collected in different containers having the same field sample ID are considered the same and therefore labeled with the same lab sample ID unless otherwise specified by the project.
- 15.1.8. Sample Duplicate – is a replicate of a sub-sample taken from one sample, prepared and analyzed within the same preparation batch.
- 15.1.9. Sub-sample – is an aliquot taken from a sample for analysis. Each sub-sample is uniquely identified by the sample preparation ID.
- 15.1.10. Matrix – is a component or form of a sample.

## STANDARD OPERATING PROCEDURE

**pH, SOLID AND WASTE SAMPLES**SOP No.: EMAX-9045 Revision No. 4 Date: 22-Jun-17

---

15.1.11. Reagent Water – is purified water free from any target analyte or any other substance that may interfere with the analytical process.

**15.2. Application of EMAX QC Procedures**

15.2.1. The procedures and QC criteria summarized in this SOP shall be applied to all projects when performing pH measurement. In instances where there is a project or program QAPP, the requirements given in the project shall take precedence over this SOP.

**15.3. Department of Defense (DoD) and Department of Energy (DoE) Projects**

15.3.1. Samples from DoD and DoE sponsored projects shall follow the Quality Assurance Project Plan (QAPP), Statement of Work (SOW) and/or client's quality control directive. In the absence of QAPP, the DoD Quality Systems Manual (QSM), latest update, shall be applied.

**16.0 REFERENCES**

- 16.1. Test Methods for Evaluating Solid Waste, Physical/Chemical Method, SW-846 Method 9045D, Rev. 4, Nov. 2004
- 16.2. EMAX Quality Systems Manual, us updated

**17.0 APPENDICES****17.1. Figures**

- 17.1.1. Figure 1 Typical Sample Result Summary
- 17.1.2. Figure 2 Typical Sample Duplicate Result Summary
- 17.1.3. Figure 3 Typical Case Narrative

**17.2. Appendices**

- 17.2.1. Appendix 1 Summary of Quality Control Procedures
- 17.2.2. Appendix 2 Demonstration of Capability

**17.3. Forms**

- 17.3.1. 9045FA Analytical Run Log

**Figure 1: TYPICAL SAMPLE RESULT**

METHOD SW9045C  
 PH

```

=====
Client      : XYZ, INC.                                     Matrix      : SOLID
Project     : CLEAN PROJECT                               InstrumentID : 53
Batch No.   : 17A000
=====
  
```

| CLIENT<br>SAMPLE ID | EMAX<br>SAMPLE ID | RESULTS<br>(pH Unit) | PREP<br>FACTOR (%) | MOIST<br>(%) | LOQ<br>(pH Unit) | LOD<br>(pH Unit) | ANALYSIS<br>DATE/TIME | PREPARATION<br>DATE/TIME | DATA<br>FILE ID | CAL<br>REF | PREP<br>BATCH | COLLECTION<br>DATE/TIME | RECEIVED<br>DATE/TIME |
|---------------------|-------------------|----------------------|--------------------|--------------|------------------|------------------|-----------------------|--------------------------|-----------------|------------|---------------|-------------------------|-----------------------|
| XXYYZZ              | A000-01           | 6.45                 | 1                  | NA           | 0.1              | 0.1              | 01/12/17 18:08        | 01/12/17 17:22           | 17PHA00501      | 17PHA005   | PHA005S       | 01/10/17 08:30          | 01/12/17              |
| XXYYZZDUP           | A000-01D          | 6.46                 | 1                  | NA           | 0.1              | 0.1              | 01/12/17 18:09        | 01/12/17 17:22           | 17PHA00502      | 17PHA005   | PHA005S       | 01/10/17 08:30          | 01/12/17              |

**Figure 2: TYPICAL SAMPLE DUPLICATE RESULT**

---

EMAX QUALITY CONTROL DATA  
 SAMPLE DUPLICATE ANALYSIS

CLIENT : XYZ, INC.  
 PROJECT : CLEAN PROJECT  
 BATCH NO. : 17A000  
 METHOD : SW9045C

=====

MATRIX : SOLID  
 DILUTION FACTOR: 1 1  
 SAMPLE ID : XXYZZZ XXYZZDUP  
 LAB SAMPLE ID : A000-01 A000-01D  
 LAB FILE ID : 17PHA00501 17PHA00502  
 DATE PREPARED : 01/12/1717:22 01/12/1717:22  
 DATE ANALYZED : 01/12/1718:08 01/12/1718:09  
 PREP BATCH : PHA005S PHA005S  
 CALIBRATION REF: 17PHA005 17PHA005

ACCESSION:

| PARAMETER | PARENT RESULT<br>(pH Unit) | DUP RESULT<br>(pH Unit) | DIFFERENCE<br>(pH Unit) | MAX DIFF.<br>(+/- pH Unit) |
|-----------|----------------------------|-------------------------|-------------------------|----------------------------|
| PH        | 6.45                       | 6.46                    | .01                     | 0.1                        |

**Figure 3:**

**TYPICAL CASE NARRATIVE**

---

CASE NARRATIVE

Client : XYZ, INC.

Project: CLEAN PROJECT

SDG : 17A000

METHOD SW9045C

PH

One (1) solid sample was received on 01/12/17 to be analyzed for pH in accordance with Method SW9045C and project specific requirements.

Holding Time

The sample was analyzed within the prescribed holding time.

Calibration

pH meter was calibrated per instrument operating manual instruction. Calibration was verified using a secondary source (ICV). Continuing calibration (CCV) verifications were carried out on a frequency specified by the project. All calibration requirements were within acceptance criteria.

Matrix QC Sample

Sample duplicate was analyzed and RPD was within expected value.

Sample Analysis

The sample was analyzed according to prescribed analytical procedures. Results were evaluated in accordance to project requirements. For this SDG, all quality control requirements were met.



**Appendix 1: SUMMARY OF QUALITY CONTROL PROCEDURES**

| QC PROCEDURE               | FREQUENCY  | ACCEPTANCE CRITERIA           | CORRECTIVE ACTION   | 1 <sup>ST</sup><br>Rvw | 2 <sup>ND</sup><br>Rvw |
|----------------------------|--|-------------------------------|---|------------------------|------------------------|
| 3 Pt. Initial Calibration  | Daily  | Buffers within ± 0.05 pH unit | Correct the problem and Re-calibrate before sample analysis.  |                        |                        |
| Calibration Check Standard | After initial calibration and every after 20 field samples | Buffers within ± 0.05 pH unit | Re-analyze. If still outside QC limits, re-calibrate and re-analyze   |                        |                        |
| Duplicate Sample           | One per analytical batch (≤ 20 field samples)              | Results within ± 0.1 pH unit  | Re-analyze the sample and its duplicate once. If it still fails QC limits, re-calibrate using a fresh buffer solution and re-analyze. |                        |                        |
| Comments:                  |  |                               |   | Reviewed By:           |                        |
|                            |  |                               |   | Date:                  |                        |

**Appendix 2: DEMONSTRATION OF CAPABILITY**

---

SOP: EMAX-9045 Rev. 4

Conc Unit: pH units  
 Sample Amount (ml): 20  
 Analysis date: 5/26/2017  
 Analyzed by: TKosak

| PARAMETER | 17PHE01201 | 17PHE01202 | 17PHE01203 | 17PHE01204 | TV | Ave.<br>Conc. | Ave.<br>%Rec | SD    | RSD<br>(%) | QC Criteria<br>(pH units) | COMMENTS |
|-----------|------------|------------|------------|------------|----|---------------|--------------|-------|------------|---------------------------|----------|
|           | PHE012WL   | PHE012WC   | PHE012WX   | PHE012WY   |    |               |              |       |            |                           |          |
| pH        | 7.01       | 7.03       | 7.02       | 7.02       | 7  | 7.02          | 100          | 0.008 | 0.1        | 6.95 - 7.05               | PASSED   |

